



Guide Ball Bushing/Linear Bushing

THK General Catalog

Guide Ball Bushing/Linear Bushing

THK General Catalog

A Product Descriptions

Features and Types	A4-4	Model LME	A4-48
Features of the Guide Ball Bushing	A4-4	Model LM-L	A4-50
• Structure and Features	A4-4	Model LMF	A4-52
• Examples of Changing the Linear Bushing to the Guide Ball Bushing ..	A4-6	Model LMF-M (Stainless Steel Type)	A4-54
Types of the Guide Ball Bushing	A4-7	Model LMF-L	A4-56
• Types and Features	A4-7	Model LMF-ML (Stainless Steel Type) ..	A4-58
Point of Selection	A4-8	Model LMK	A4-60
Flowchart for Selecting a Guide Ball Bushing ..	A4-8	Model LMK-M (Stainless Steel Type)	A4-62
• Steps for Selecting a Guide Ball Bushing ..	A4-8	Model LMK-L	A4-64
Rated Load and Nominal Life	A4-9	Model LMK-ML (Stainless Steel Type) ..	A4-66
Table of Equivalent Factors	A4-13	Model LMJK	A4-68
Precautions To Be Taken if an Eccentric Load Is Applied ..	A4-13	Model LMJK-L	A4-70
Accuracy Standards	A4-13	Model LMH	A4-72
Dimensional Drawing, Dimensional Table		Model LMH-M (Stainless Steel Type)	A4-74
Model LG	A4-14	Model LMH-L	A4-76
Point of Design	A4-16	Model LMH-ML (Stainless Steel Type) ..	A4-78
Assembling the Guide Ball Bushing	A4-16	Model LMIF	A4-80
Options	A4-19	Model LMIF-L	A4-82
Lubrication	A4-19	Model LMCFL	A4-84
Dust prevention	A4-19	Model LMIK	A4-86
Model No.	A4-20	Model LMIK-L	A4-88
• Model Number Coding	A4-20	Model LMCK-L	A4-90
Precautions on Use	A4-21	Model LMIH	A4-92
Features and Types	A4-23	Model LMIH-L	A4-94
Features of the Linear Bushing	A4-23	Model LMCH-L	A4-96
• Structure and Features	A4-23	Models SC6 to 30	A4-98
Types of the Linear Ball Bushing	A4-24	Models SC35 to 50	A4-100
• Types and Features	A4-24	Model SL	A4-102
Classification Table	A4-34	Model SH	A4-104
Point of Selection	A4-36	Model SH-L	A4-106
Flowchart for Selecting a Linear Bushing ..	A4-36	Model SK	A4-108
• Steps for Selecting a Linear Bushing	A4-36	• Standard LM Shafts	A4-109
Rated Load and Nominal Life	A4-37	• Specially Machined Types	A4-110
Table of Equivalent Factors	A4-41	• Dedicated Shafts	A4-111
Precautions To Be Taken if an Eccentric Load Is Applied ..	A4-41	• Table of Rows of Balls and Masses for Clearance-adjustable Types and Open Types of the Linear Bushing	A4-111
Accuracy Standards	A4-41	Point of Design	A4-112
Dimensional Drawing, Dimensional Table		Assembling the Linear Bushing	A4-112
Model LM	A4-42	Options	A4-119
Model LM-GA (Metal Retainer Type)	A4-44	Lubrication	A4-119
Model LM-MG (Stainless Steel Type)	A4-46	Material and Surface Treatment	A4-119
		Dust prevention	A4-120
		Felt Seal Model FLM	A4-120
		Model No.	A4-121
		• Model Number Coding	A4-121
		Precautions on Use	A4-123

B Support Book (Separate)

Features and Types	B4-4
Features of the Guide Ball Bushing	B4-4
• Structure and Features	B4-4
• Examples of Changing the Linear Bushing to the Guide Ball Bushing ..	B4-6
Types of the Guide Ball Bushing	B4-7
• Types and Features	B4-7
Point of Selection	B4-8
Flowchart for Selecting a Guide Ball Bushing ..	B4-8
• Steps for Selecting a Guide Ball Bushing ..	B4-8
Rated Load and Nominal Life	B4-9
Precautions To Be Taken if an Eccentric Load Is Applied ..	B4-12
Mounting Procedure and Maintenance ..	B4-13
Assembling the Guide Ball Bushing	B4-13
Options	B4-16
Lubrication	B4-16
Dust prevention	B4-16
Model No.	B4-17
• Model Number Coding	B4-17
Precautions on Use	B4-18
Features and Types	B4-20
Features of the Linear Bushing	B4-20
• Structure and Features	B4-20
Types of the Linear Ball Bushing	B4-22
• Types and Features	B4-22
Classification Table	B4-32
Point of Selection	B4-34
Flowchart for Selecting a Linear Bushing ..	B4-34
• Steps for Selecting a Linear Bushing	B4-34
Rated Load and Nominal Life	B4-35
Precautions To Be Taken if an Eccentric Load Is Applied ..	B4-38
Mounting Procedure and Maintenance ..	B4-39
Assembling the Linear Bushing	B4-39
Options	B4-46
Lubrication	B4-46
Material and Surface Treatment	B4-46
Dust prevention	B4-47
Felt Seal Model FLM	B4-47
Model No.	B4-48
• Model Number Coding	B4-48

Precautions on Use	B4-50
---------------------------------	-------

Features of the Guide Ball Bushing

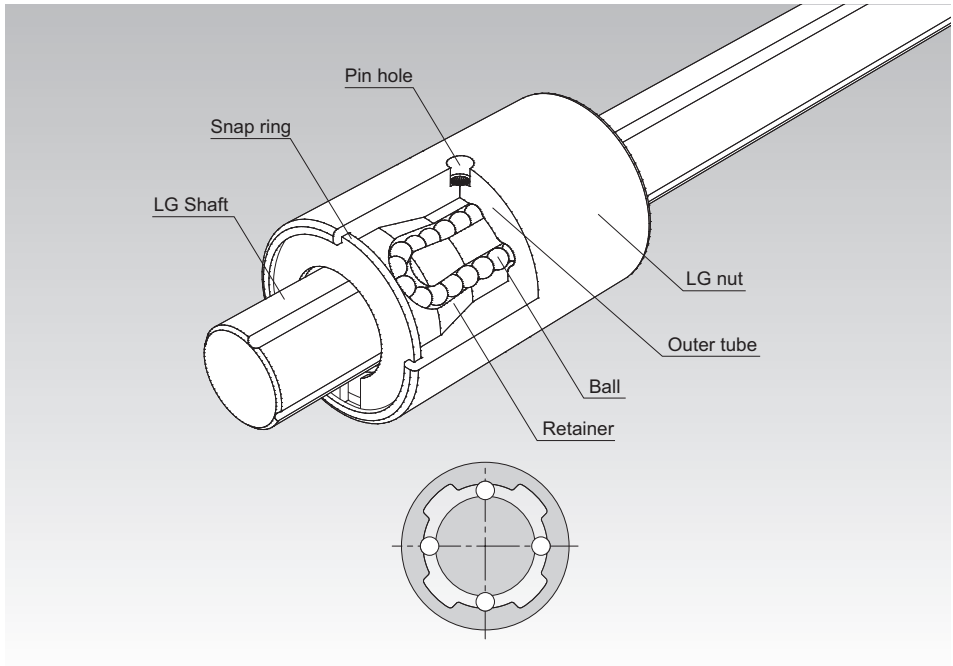

Fig.1 Structure of the Guide Ball Bushing model LG

Structure and Features

Since model LG has 4 rows of circular arc grooves (raceways), it does not need a mechanism to prevent the outer tube from rotating. In addition, its load rating is much larger than Linear Bushing model LM with the same dimensions. Therefore, replacing the Linear Bushing with the Guide Ball Bushing will reduce the size and cost of the guide unit and extend the service life.

Features and Types

Features of the Guide Ball Bushing

[Higher Load Rating than the Linear Bushing]

Since model LG ensures an R contact through the use of circular arc grooves for ball contact, it achieves a load rating more than twice that of point-contact Linear Bushing model LM with the same size.

[A Rotation Stopper is Unnecessary Because of Raceways]

Since model LG has circular arc grooves, it does not need a rotation stopper required for Linear Bushing model LM, and allows the machine design to be compact.

[Interchangeable in Dimensions with Linear Bushing Model LM]

Since the outer tube of model LG has the same outer diameter and length as that of Linear Bushing model, LM, it is possible to replace Linear Bushing model LM with Guide Ball Bushing model LG as assemblies.

[Various Combinations of Nut and Shaft are Available (Any Combination is Allowed)]

As with the Linear Bushing, any combination of the LG nut and the LG shaft of model LG is allowed.

Examples of Changing the Linear Bushing to the Guide Ball Bushing

[Advantage of using the Guide Ball Bushing 1: Longer service life]

Since model LG has a rated load more than 2.4 times the Linear Bushing with the same dimensions, replacing the Linear Bushing with model LG will increase the service life by more than 13.8 times.

Table1 Comparison of the service life between Guide Ball Bushing mode LG and Linear Bushing model LM

Model No.	Basic dynamic load rating: C [N]	Load rating ratio	Service life ratio
LG4S	335	3.8 times	54.8 times
LM4	88.2		
LG6S	494	2.4 times	13.8 times
LM6	206		
LG8S	796	3.0 times	27.0 times
LM8	265		

[Advantage of using the Guide Ball Bushing 2: Smaller machine size]

Since the Linear Bushing is not suitable for applications where a load in the rotational direction is applied, it is necessary to use two or more Linear Bushing units in parallel or have a rotation stopper mechanism even under conditions where a torque is not applied. In contrast, the Guide Ball Bushing, which has a structure containing four rows of circular arc grooves, is operable with a single shaft and therefore contributes to downsizing the machine, unless an excessive load is applied.

Achieves a load carrying capacity approximately three times the Linear Bushing in a half space

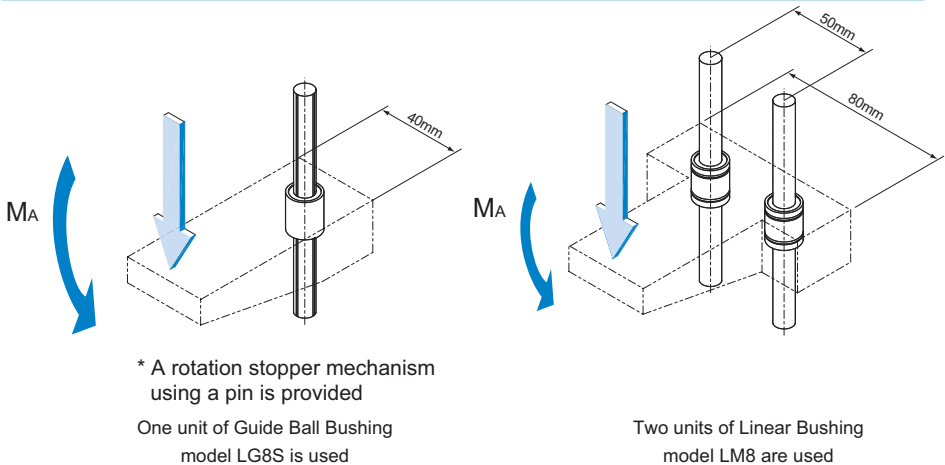

Table2 Comparison of the permissible moment between Guide Ball Bushing mode LG and Linear Bushing model LM

Model No.	Permissible moment: M_A [N·m]
One unit of LG8S is used	1.46
Two units of LM8 are used	0.45

Types of the Guide Ball Bushing

Types and Features

Model LG-S

Specification Table⇒ **A4-14**

In this type, the diameter and the length of the LG nut are the same as that of Linear Bushing model LM. This type is dimensionally interchangeable with model LM.

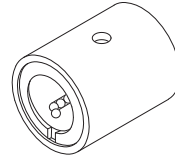

Model LG-L

Specification Table⇒ **A4-14**

Model LG-L is a long type in which the overall length of the LG nut is longer than that of model LG-S to increase the load carrying capacity.

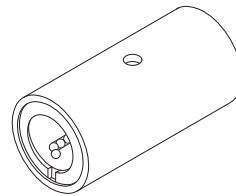

Flowchart for Selecting a Guide Ball Bushing

Steps for Selecting a Guide Ball Bushing

The following flowchart should be used as a guide for selecting a Guide Ball Bushing.

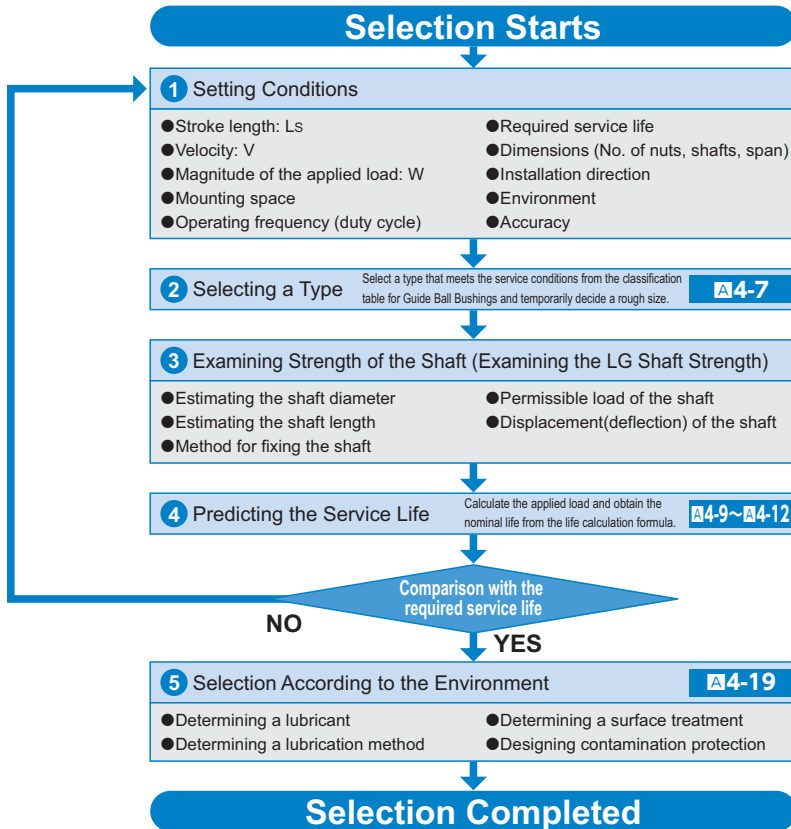

Rated Load and Nominal Life

[Load Rating]

The rated load of the Guide Ball Bushing varies according to the position of balls in relation to the load direction. The basic load ratings indicated in the specification tables each indicate the value when one row of balls receiving a load are directly under the load.

If the Guide Ball Bushing is mounted so that two rows of balls evenly receive the load in the load direction, the rated load changes as shown in Table1.

Table1 Rated load of the Guide Ball Bushing

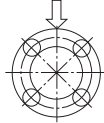
Rows of balls	Ball position	Load Rating
4 rows		$1.41 \times C$

Note: For specific values for "C" above, see the respective specification table.

[Calculating the Nominal Life]

The nominal life of the THK guide ball bushing is defined as 50 km. The nominal life (L_{10}) is calculated from the basic dynamic load rating (C) and the load acting on the guide ball bushing (P_c) using the following formula.

$$L_{10} = \left(\frac{C}{P_c} \right)^3 \times 50 \quad \dots\dots(1)$$

L_{10} : Nominal life (km)
 C : Basic dynamic load rating (N)
 P_c : Calculated load (N)

*This nominal life formula may not apply if the length of the stroke is less than or equal to twice the length of the nut.

When comparing the nominal life (L_{10}), you must take into account whether the basic dynamic load rating was defined based on 50 km or 100 km. Convert the basic dynamic load rating based on ISO 14728-1 as necessary.

ISO-regulated basic dynamic load rating conversion formula:

$$C_{100} = \frac{C_{50}}{1.26}$$

C_{50} : Basic dynamic load rating based on a nominal life of 50 km
 C_{100} : Basic dynamic load rating based on a nominal life of 100 km

[Calculating the Modified Nominal Life]

During use, a guide ball bushing may be subjected to vibrations and shocks as well as fluctuating loads, which are difficult to detect. In addition, the surface hardness of the raceways, the operating temperature, and having blocks arranged directly behind one another will have a decisive impact on the service life. Taking these factors into account, the modified nominal life (L_{10m}) can be calculated according to the following formula (2).

•Modified factor α

$$\alpha = \frac{f_H \cdot f_T \cdot f_c}{f_w}$$

α : Modified factor
 f_H : Hardness factor (see Fig.1 on **A4-11**)
 f_T : Temperature factor
 f_c : Contact factor (see Table2 on **A4-12**)
 f_w : Load factor (see Table 3 on **A4-12**)

•Modified nominal life L_{10m}

$$L_{10m} = \left(\alpha \times \frac{C}{P_c} \right)^3 \times 50 \quad \dots\dots(2)$$

L_{10m} : Modified nominal life (km)
 C : Basic dynamic load rating (N)
 P_c : Calculated load (N)

● **When a Moment Load is Applied to a Single Nut or Two Nuts in Close Contact with Each Other**

When a moment load is applied to a single nut or two nuts in close contact with each other, calculate the equivalent radial load at the time the moment is applied.

$$P_v = K \cdot M$$

P_v : Equivalent radial load (N)
(with a moment applied)

K : Equivalent factors
(see Table4 to Table5 on **A4-13**)

M : Applied moment (N·mm)

However, " P_v " is assumed to be within the basic static load rating (C_0).

● **When a Moment Load and a Radial Load are Simultaneously Applied**

When a moment and a radial load are applied simultaneously, calculate the service life based on the sum of the radial load and the equivalent radial load.

■ **f_H : Hardness Factor**

To maximize the load capacity of the Guide Ball Bushing, the hardness of the raceways needs to be between 58 to 64 HRC.

If the hardness is lower than this range, the basic dynamic load rating and the basic static load rating decrease. Therefore, it is necessary to multiply each rating by the respective hardness factor (f_H).

Normally, $f_H = 1.0$ since the Guide Ball Bushing has sufficient hardness.

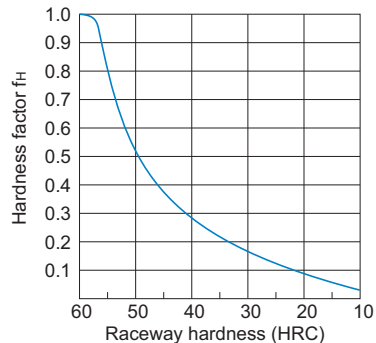

Fig.1 Hardness Factor (f_H)

■ **f_T : Temperature Factor**

The temperature of the environment where the Guide Ball Bushing is used must be 80°C or below. Therefore, adopt a temperature factor $f_T = 1.0$.

The Guide Ball Bushing does not support high temperature. Therefore, if the environment temperature exceeds 80°C, it is necessary to use another product.

■ f_c : Contact Factor

When multiple nuts are used in close contact with each other, their linear motion is affected by moments and mounting accuracy, making it difficult to achieve uniform load distribution. In such applications, multiply the basic load rating (C) and (C₀) by the corresponding contact factor in Table2.

Note) If uneven load distribution is expected in a large machine, take into account the respective contact factor indicated in Table2.

Table2 Contact Factor (f_c)

Number of nuts in close contact with each other	Contact factor f_c
2	0.81
3	0.72
4	0.66
5	0.61
Normal use	1

■ f_w : Load Factor

In general, reciprocating machines tend to experience vibrations or impacts during operation, and it is extremely difficult to accurately determine the vibrations generated during high-speed operation and impacts during frequent starts and stops. Therefore, when the actual load applied to a guide ball bushing cannot be obtained, or when speed and vibrations have a significant influence, divide the basic dynamic load rating (C) by the corresponding load factor in Table 3, which has been empirically obtained.

Table 3 Load Factor (f_w)

Vibrations/ impact	Speed(V)	f_w
Faint	Very low $V \leq 0.25\text{m/s}$	1 to 1.2
Weak	Slow $0.25 < V \leq 1\text{m/s}$	1.2 to 1.5
Medium	Medium $1 < V \leq 2\text{m/s}$	1.5 to 2
Strong	High $V > 2\text{m/s}$	2 to 3.5

[Calculating the Service Life Time]

When the nominal life (L_{10}) has been obtained, if the stroke length and the number of reciprocations per minute are constant, the service life time is obtained using the following equation.

$$L_h = \frac{L_{10} \times 10^3}{2 \times \ell_s \times n_1 \times 60}$$

L_h : Service life time (h)

ℓ_s : Stroke length (m)

n_1 : Number of reciprocations per minute (min^{-1})

Table of Equivalent Factors

Table4 Equivalent Factors of Model LG-S

Model No.	Equivalent factor: K	
	Single nut	Double blocks
LG 4S	1.062	0.193
LG 6S	0.885	0.121
LG 8S	0.708	0.096

Table5 Equivalent Factors of Model LG-L

Model No.	Equivalent factor: K
	Single nut
LG 4L	0.733
LG 6L	0.465
LG 8L	0.442

Precautions To Be Taken if an Eccentric Load Is Applied

Model LG achieves a much higher load-carrying capacity in receiving the eccentric load (moment and torque) than Linear Bushing model LM because of 4 rows of raceways. However, under conditions where the eccentric load is larger, the product may result in poor operation or early failure. In such cases, we recommend using Ball Spline model LBS or LT, both of which have larger load-carrying capacities (see **A3-52** onward for model LBS, or **A3-76** onward for model LT).

Accuracy Standards

[Guide Ball Bushing]

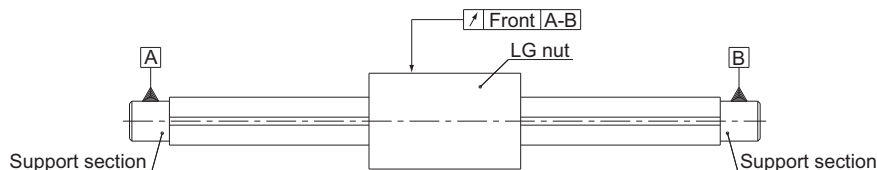

Table6 Run-out of the outer diameter of the nut relative to the support section of the shaft

Unit: μm

Overall shaft length (mm)		Run-out(max)*
-	200 or less	72
Above 200	250 or less	133

*: The value if the radial clearance is zero

Model LG

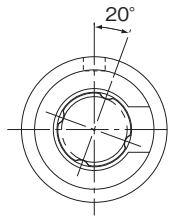

Model No.	Shaft Diameter D _o h7	Nut dimensions					
		Outer diameter		Length		Pin hole	
		D	Tolerance	L	Tolerance	b +0.05 0	t +0.08 -0.02
LG4S	4	8	0	12	0	1.2	0.8
LG4L		8	-0.009	19	-0.12	1.2	0.8
LG6S	6	12	0	19	0	1.5	1.2
LG6L		12		27		1.5	1.2
LG8S	8	15	-0.011	24	-0.2	2	1.5
LG8L		15		30		2	1.5

Note) The basic load ratings each indicate the value when one row of balls receiving a load are directly under the load.
 The permissible torques each represent a reference value when the radial clearance is maximum (+10 μ m).
 The permissible moments each indicate a reference value when the radial clearance is the maximum (+10 μ m) with one row of balls receiving a load being directly under the load.

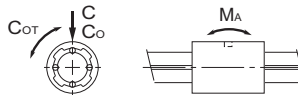

Model number coding

① LG shaft only

LG4 -100L

Model No.

Overall LG shaft length

② LG nut only

LG4S

Model No.

③ A set product consisting of an LG shaft and an LG nut

2 LG4S +100L

Model No.

Overall LG shaft length

Number of LG nuts on one shaft
(no symbol for one nut)

Note) Model LG guide ball bushing available as LG shaft ①, or the LG nut ② separate.

A set consisting of an ③ LG shaft + an LG nut is also available if so desired.

A special radial clearance, designated grease application (standard type is applied only with antirust oil) and surface treatment (THK AP-C treatment, THK AP-CF treatment, THK AP-HC treatment) are also available.

Contact THK for details.

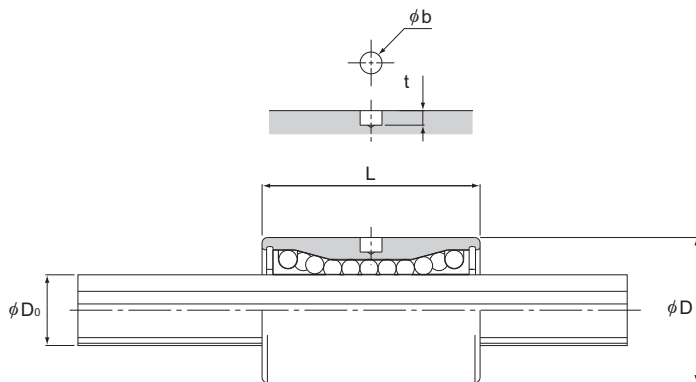

Unit: mm

	Basic load rating (radial)		Permissible torque C_{0T} N·m	Permissible moment M_A N·m	Mass g
	C N	C_0 N			
	335	473	0.066	0.33	2.5
	466	757	0.105	0.71	4.0
	494	681	0.241	0.74	10.5
	860	1499	0.530	1.71	14.0
	796	1065	0.838	1.46	16.5
	1203	1916	1.509	2.66	22.0

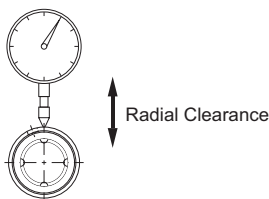
[Radial Clearance]

Measurement of a radial clearance

Radial Clearance Unit: μm

Normal clearance
0 to +10

[LG Shaft]

Material: SUJ2

Hardness: 56 to 64 HRC



LG shaft dimensions Unit: mm

Model No.	Shaft diameter D_0 h7	Standard length L				Maximum manufacturing length	Mass (g/m)
		100	150	200	250		
LG4	4	100	150	—	—	150	95
LG6	6	100	150	200	—	200	220
LG8	8	100	150	200	250	250	390

Assembling the Guide Ball Bushing

[Inner Diameter of the Housing]

Table1 shows recommended housing inner-diameter tolerance for the Guide Ball Bushing. When fitting the Guide Ball Bushing with the housing, loose fit is normally recommended. If the clearance needs to be smaller, provide transition fit.

Table1 Housing Inner-diameter Tolerance

General conditions	H6
If the accuracy does not need to be very high	H7

[Mounting the Nut]

Although the Guide Ball Bushing does not require a large amount of strength for securing it in the LG shaft direction, do not support the nut only with driving fitting. For the housing inner-diameter tolerance, see Table1.

- Mounting model LG using a pin

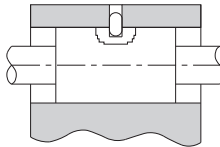

- Mounting model LG as with the conventional Linear Bushing

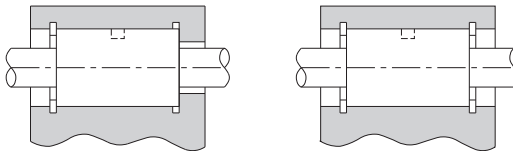

Snap Ring

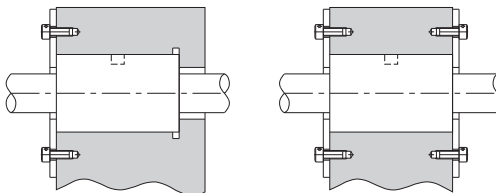

Stopper Plate

Point of Design

Assembling the Guide Ball Bushing

■Snap Ring for Installation

To secure the Guide Ball Bushing model LG, snap rings indicated in Table2 are available.

Table2 Types of Snap Rings

Model No.	Snap ring	
	For inner surface	
	Needle snap ring	C-shape snap ring
LG 4	8	—
LG 6	12	12
LG 8	15	15

■Set Screws Not Allowed

Securing the nut by pressing the outer surface with one set screw as shown in Fig.1 will cause the nut to be deformed.

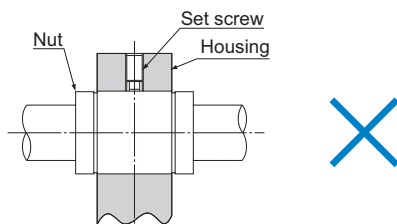

Fig.1

[Incorporating the Nut]

When incorporating the Guide Ball Bushing into a housing, use a jig and drive in the nut, or use a flatter plate and gently hit the nut, instead of directly hitting the side plate or the seal. (see Fig.2).

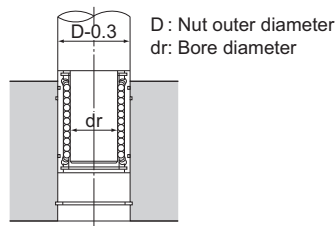

Fig.2

Unit: mm

Model No.	dr	Tolerance
LG 4S/LG 4L	3.6	-0.1 -0.3
LG 6S/LG 6L	5.6	
LG 8S/LG 8L	7.5	

[Inserting the LG Shaft]

When inserting the LG shaft into the Guide Ball Bushing, align the center of the shaft with that of the nut and gently insert the shaft straightforward into the nut. If the shaft is slanted while it is inserted, balls may fall off or the retainer may be deformed (see Fig.3).

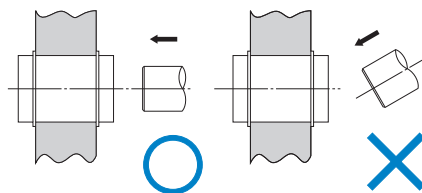

Fig.3

[When Under a Moment Load]

When using the Guide Ball Bushing, make sure that the load is evenly distributed on the whole ball raceway. In particular, if a moment load is applied, use two or more Guide Ball Bushing units on the same LG shaft and secure an adequately large distance between the units.

If using the Guide Ball Bushing under a moment load, also calculate the equivalent radial load and identify the correct model number. (See **A4-11**.)

Lubrication

The Guide Ball Bushing requires grease or oil as a lubricant for its operation.

[Grease Lubrication]

Before mounting the product onto the LG shaft, apply grease to each row of balls inside the Guide Ball Bushing.

Thereafter apply grease as necessary, in accordance with usage and other conditions noted above, or attach housing as shown in Fig.1, or apply grease directly to the LG shaft.

We recommend using lithium soap-based grease No. 2.

[Oil Lubrication]

To lubricate, apply lubricant to the LG shaft one drop at a time, as needed, or attach housing as shown in Fig.1, in the same manner as when lubricating with grease.

Commonly used lubricants include turbine oil, machine oil, and spindle oil.

In addition to the procedures described the above, an oil hole or grease nipple can also be used for lubrication. For further information, contact THK.

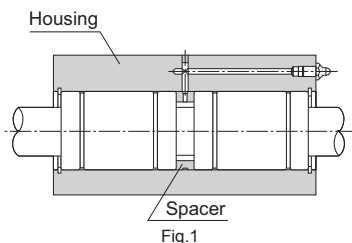

Dust prevention

Entrance of dust or other foreign material into the Guide Ball Bushing will cause abnormal wear or shorten the service life. When entrance of dust or other foreign material is a possibility, it is important to select effective seals and/or dust-control device that meets the service environment conditions. In addition, THK produces round bellows. Contact us for details.

Model Number Coding

Model number configurations differ depending on the model features. Refer to the corresponding sample model number configuration.

[Guide Ball Bushing]

Estimates and orders should be made for LG shafts alone or LG nuts alone in principle.

A set consisting of an LG shaft and an LH nut is also available if desired by the customer. Contact THK for details.

● Models LG-S and LG-L

- LG shaft only

LG4 -100L

Model No.
of LG shaft

Overall LG shaft length (in mm)

- LG nut only

LG4S

Model No. of LG nut

- Combination of
LG shaft and LG nut

2 LG4S +100L

Model No.
of LG nut

Overall LG shaft length (in mm)

Number of LG nuts on one shaft
(no symbol for one nut)

A special radial clearance, designated grease application (standard product is applied with antirust oil only), and surface treatment (THK AP-C treatment, THK AP-CF treatment, THK AP-HC treatment) are also available. Contact THK for details.

[Handling]

- (1) Disassembling each part may cause dust to enter the system or degrade mounting accuracy of parts. Do not disassemble the product.
- (2) Take care not to drop or strike the Guide Ball Bushing. Doing so may cause injury or damage. Giving an impact to it could also cause damage to its function even if the product looks intact.
- (3) When handling the product, wear protective gloves, safety shoes, etc., as necessary to ensure safety.

[Precautions on Use]

- (1) Prevent foreign material, such as cutting chips or coolant, from entering the product. Failure to do so may cause damage.
- (2) If the product is used in an environment where cutting chips, coolant, corrosive solvents, water, etc., may enter the product, use bellows, covers, etc., to prevent them from entering the product.
- (3) Do not use the product at temperature of 80°C or higher. Exposure to higher temperatures may cause the resin/rubber parts to deform/be damaged.
- (4) If foreign material such as cutting chips adheres to the product, replenish the lubricant after cleaning the product.
- (5) Micro-strokes tend to obstruct oil film to form on the raceway in contact with the rolling element, and may lead to fretting corrosion. Take consideration using grease offering excellent fretting prevention. It is also recommended that a stroke movement corresponding to the length of the outer cylinder be made on a regular basis to make sure oil film is formed between the raceway and rolling element.
- (6) Do not use undue force when fitting parts (pin, key, etc.) to the product. This may generate permanent deformation on the raceway, leading to loss of functionality.
- (7) Insert the shaft straight through the opening. Inserting the shaft at an angle can introduce foreign matter, damage internal components, or cause balls to fall out.
- (8) Using this product with any balls removed may result in premature damage.
- (9) Please contact THK if any balls fall out; do not use the product if any balls are missing.
- (10) If an attached component is insufficiently rigid or mounted incorrectly, the bearing load will be concentrated at one location and performance will decline significantly. Make sure the housing and base are sufficiently rigid, the anchoring bolts are strong enough, and the component is mounted correctly.

[Lubrication]

- (1) Thoroughly wipe off anti-rust oil and feed lubricant before using the product.
- (2) Do not mix different lubricants. Mixing greases using the same type of thickening agent may still cause adverse interaction between the two greases if they use different additives, etc.
- (3) When using the product in locations exposed to constant vibrations or in special environments such as clean rooms, vacuum and low/high temperature, use the grease appropriate for the specification/environment.
- (4) To lubricate the product, apply lubricant directly to the raceway surface and execute a few preliminary strokes to ensure that the interior is fully lubricated.
- (5) The consistency of grease changes according to the temperature. Take note that the slide resistance of the Guide Ball Bushing also changes as the consistency of grease changes.

- (6) After lubrication, the slide resistance of the Guide Ball Bushing may increase due to the agitation resistance of grease. Be sure to perform a break-in to let the grease spread fully, before operating the machine.
- (7) Excess grease may scatter immediately after lubrication, so wipe off scattered grease as necessary.
- (8) The properties of grease deteriorate and its lubrication performance drops over time, so grease must be checked and added properly according to the use frequency of the machine.
- (9) The greasing interval varies depending on the use condition and service environment. Set the final lubrication interval/amount based on the actual machine.

[Assembling the LG Nut with the LG Shaft of the Guide Ball Bushing]

- (1) When assembling the LG nut with the LG shaft, align the position of the balls inside the LG nut with the position of the groove of the LG shaft, then insert the LG shaft into the LG nut straightforward and gradually. If the LG shaft is tilted when it is inserted, balls may bounce out or damage the circulating part.
- (2) If the LG shaft is stuck in the middle of insertion, do not force it into the nut. Instead, pull it out first, re-check the ball position and the LG shaft groove position, and then insert it straightforward and gradually.
- (3) After assembling the LG nut with the LG shaft, check that the LG nut or the LG shaft smoothly moves. If the shaft was forced into the nut, function could be lost even if the product looks intact.

[Storage]

When storing the Guide Ball Bushing, enclose it in a package designated by THK and store it in a room while avoiding high temperature, low temperature and high humidity.

[Disposal]

Dispose of the product properly as industrial waste.

Features of the Linear Bushing

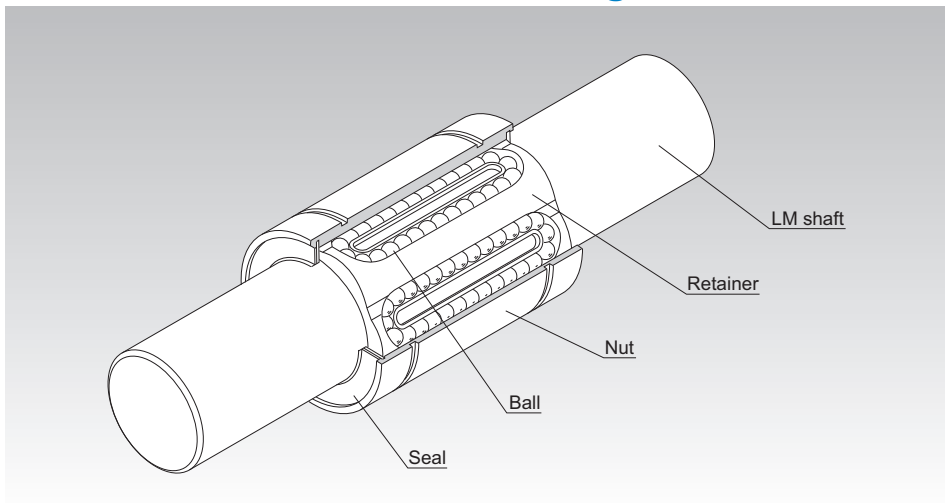

Fig.1 Structure of Linear Bushing Model LM···UU

Structure and Features

The linear bushing is a linear motion product that is used in combination with a cylindrical LM shaft. The ball bearings in the load area offer point contact with the LM shaft. This allows straight motion with minimal friction resistance and therefore smooth motion.

High-carbon chromium bearing steel is used for the nut, and the outer and inner surfaces are ground and heat-treated.

Linear bushings are used for medical equipment, packing equipment, and lightweight OA equipment that is not subject to vibration, shock, etc.

However, they cannot be used for applications in which loads are applied in a rotational direction.

[Interchangeability]

The linear bushing and LM shaft are interchangeable, allowing for use in any combination.

[Low Noise]

A molded resin retainer is incorporated into the standard type in order to prevent the balls from falling out. This also provides silent and smooth operation.

[Wide Array of Types]

A wide array of types are available, such as the Standard Type, Clearance-adjustable Type, Open Type, Long Type, Fitted Flange Type, and Flanged Linear Bushing, allowing the user to select a type that suits the intended application.

Types of the Linear Ball Bushing

Types and Features

Standard Type

Specification Table⇒ [A4-42](#)/[A4-44](#)/[A4-46](#)/[A4-48](#)

The most standard type with a wide range of applications.

- Model LM SUJ2 Type
This product series has commonly used dimensions
- Model LM-GA SUJ2 Type
Features the Model LM-GA metal retainer
- Model LM-MG SUS Type
- Model LME SUJ2 Type
This product series has dimensions commonly used in Europe

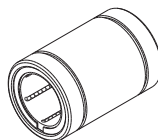

Standard Type

Clearance-adjustable Type

Specification Table⇒ [A4-42](#)/[A4-44](#)/[A4-46](#)/[A4-48](#)

A standard nut with a slit in the direction of the LM shaft.

The clearance between the LM shaft and housing can be adjusted by installing the shaft to a housing with an adjustable inner diameter.

- Models LM-AJ/LM-GA-AJ/LME-AJ... Made of SUJ2
- Model LM-MG-AJ SUS Type

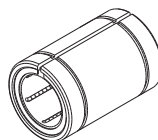

Clearance-adjustable Type

Open Type

Specification Table⇒ [A4-42](#)/[A4-44](#)/[A4-46](#)/[A4-48](#)

The nut features a cut equal to the width of one row of ball bearings (50° to 80°).

This enables it to be used even in locations where the LM shaft is supported by a column or fulcrum. In addition, the clearance can be adjusted.

- Models LM-OP/LM-GA-OP/LME-OP... Made of SUJ2
- Model LM-MGA-OP SUS Type

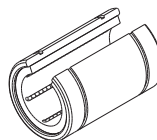

Open Type

Long Type

Incorporates two standard type retainers, giving it a large net rated load.

Model LM-L SUJ2 Type

Specification Table⇒ **A-4-50**

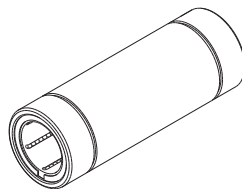

Long Type

Flanged Type (Round)

Easy to mount because the spline nut can be directly attached to the housing.

Model LMF SUJ2 Type

Model LMF-M SUS Type

Specification Table⇒ **A-4-52/A-4-54**

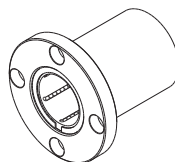

Flanged Type (Round)

Flanged Type (Round) - Long

Incorporates two standard type retainers, giving it a large net rated load.

Model LMF-L SUJ2 Type

Model LMF-ML SUS Type

Specification Table⇒ **A-4-56/A-4-58**

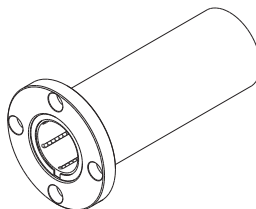

Flanged Type (Round) - Long

Flanged Type (Square)

Features a Model LMF flange that has been flattened on four sides.

The lower core height compared to circular flanges allows for more compact designs.

Model LMK SUJ2 Type

Model LMK-M SUS Type

Specification Table⇒ [A4-60/A4-62](#)

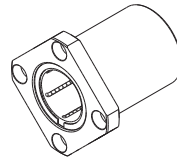

Flanged Type (Square)

Flanged Type (Square) - Long

Incorporates two standard type retainers, giving it a large net rated load.

Model LMK-L SUJ2 Type

Model LMK-ML SUS Type

Specification Table⇒ [A4-64/A4-66](#)

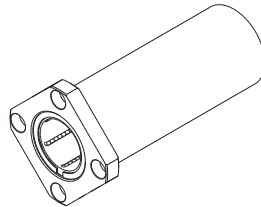

Flanged Type (Square) - Long

Lightweight Flanged Type (Square) **NEW**

Features a flange made using high strength plastic.

Weighs less than metal flanges.

Mounting this type to moving parts reduces the overall weight.

Model LMJK SUJ2 Type

Specification Table⇒ [A4-68](#)

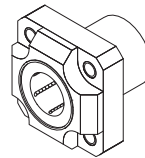

Lightweight Flanged Type (Square)

Lightweight Flanged Type (Square) - Long **NEW** Specification Table⇒ [A4-70](#)

Incorporates two standard type retainers, giving it a large net rated load.

Model LMJK-L SUJ2 Type

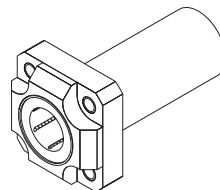

Lightweight Flanged Type (Square) - Long

Features and Types

Types of the Linear Ball Bushing

Flanged Type (Cut Flange)

Features a Model LMF flange that has been flattened on two sides.

The lower core height compared to square flanges allows for more compact designs.

The rows of bearings are aligned so that a load from one of the flattened sides will be supported by two rows of bearings.

Model LMH SUJ2 Type

Model LMH-M SUS Type

Specification Table⇒ [A4-72/A4-74](#)

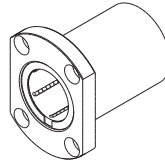

Flanged Type (Cut Flange)

Flanged Type (Cut Flange) - Long

Incorporates two standard type retainers, giving it a large net rated load.

Model LMH-L SUJ2 Type

Model LMH-ML SUS Type

Specification Table⇒ [A4-76/A4-78](#)

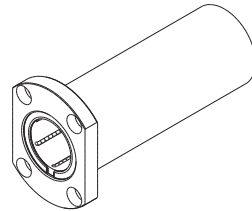

Flanged Type (Cut Flange) - Long

Fitted Flanged Type (Round)

Specification Table⇒ **A4-80**

Since the fitted part is short, the linear bushing tends not to protrude into the other side, so space is saved on the side opposite the mounting.

Model LMIF SUJ2 Type

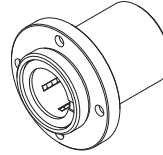

Fitted Flanged Type (Round)

Fitted Flanged Type (Round) - Long

Specification Table⇒ **A4-82**

Model LMIF - Long.

Incorporates two standard type retainers, giving it a large net rated load.

Model LMIF-L SUJ2 Type

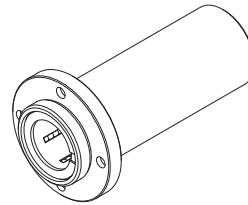

Fitted Flanged Type (Round) - Long

Center Flanged Type (Round) - Long

Specification Table⇒ **A4-84**

As work pieces can be mounted around the center of the nut, the load can be distributed and spaced evenly on either side of the flange. Ideal for making the stroke even in both directions.

Model LMCF-L SUJ2 Type

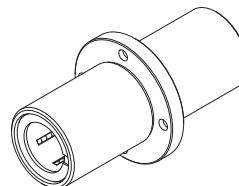

Center Flanged Type (Round) - Long

Features and Types

Types of the Linear Ball Bushing

Fitted Flanged Type (Square)

Specification Table⇒ [A-4-86](#)

The flange is similar to the Model LMIF, but flattened in four places.

The lower core height compared to circular flanges allows for more compact designs.

Model LMIK SUJ2 Type

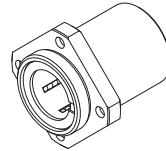

Fitted Flanged Type (Square)

Fitted Flanged Type (Square) - Long

Specification Table⇒ [A-4-88](#)

Incorporates two standard type retainers, giving it a large net rated load.

Model LMIK-L SUJ2 Type

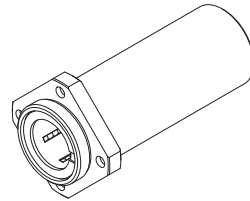

Fitted Flanged Type (Square) - Long

Center Flanged Type (Square) - Long

Specification Table⇒ [A-4-90](#)

As work pieces can be mounted around the center of the nut, the load can be distributed and spaced evenly on either side of the flange. Ideal for making the stroke even in both directions.

Model LMCK-L SUJ2 Type

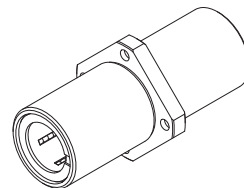

Center Flanged Type (Square) - Long

Fitted Flanged Type (Ovular)

Specification Table⇒ **A4-92**

Features a Model LMIF flange that has been flattened on two sides.

The lower core height compared to square flanges allows for more compact designs.

The rows of bearings are aligned so that a load from one of the flattened sides will be supported by two rows of bearings.

Model LMIH SUJ2 Type

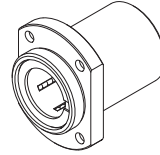

Fitted Flanged Type (Ovular)

Fitted Flanged Type (Ovular) - Long

Specification Table⇒ **A4-94**

Incorporates two standard type retainers, giving it a large net rated load.

Model LMIH-L SUJ2 Type

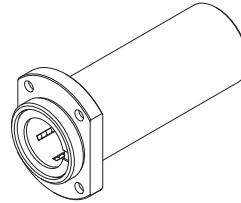

Fitted Flanged Type (Ovular) - Long

Center Flanged Type (Ovular) - Long

Specification Table⇒ **A4-96**

As work pieces can be mounted around the center of the nut, the load can be distributed and spaced evenly on either side of the flange. Ideal for making the stroke even in both directions.

Model LMCH-L SUJ2 Type

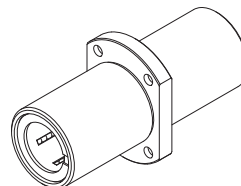

Center Flanged Type (Ovular) - Long

Features and Types

Types of the Linear Ball Bushing

Linear Bushing Model SC

It is a case unit where the standard type of Linear Bushing is incorporated into a small, light-weight aluminum casing. This model can easily be mounted simply by securing it to the table with bolts.

Specification Table⇒ **A**4-98

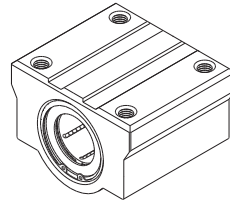

Linear Bushing Model SC

Linear Bushing (Long) Model SL

A case unit that features two standard linear bushings embedded within an aluminum casing.

Specification Table⇒ **A**4-102

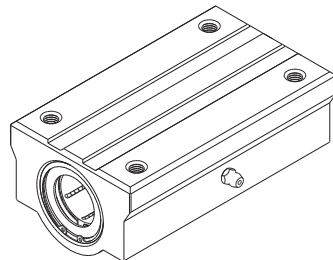

Linear Bushing (Long) Model SL

Linear Bushing Model SH

Specification Table⇒ **A4-104**

It is a case unit where the standard type of Linear Bushing is incorporated into a smaller and lighter aluminum casing than model SC. This model allows even more compact design than model SC. It also has flexibility in mounting orientation. Additionally, it is structured so that two rows of balls receive the load from the top of the casing, allowing a long service life to be achieved.

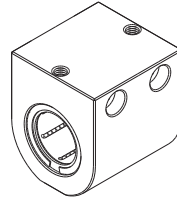

Linear Bushing Model SH

Linear Bushing (Long) Model SH-L

Specification Table⇒ **A4-106**

A long version of model SH, this model is a case unit that contains two units of the standard type Linear Bushing in an aluminum casing.

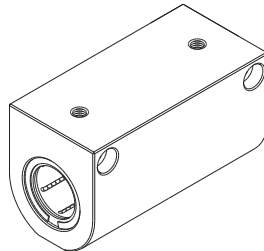

Linear Bushing (Long) Model SH-L

Features and Types

Types of the Linear Ball Bushing

Standard LM Shafts

LM shafts for use with the high quality linear bushing model LM series.

Specification Table⇒ **A-4-109**



Standard LM Shafts

Build-to-order LM Shafts

Machined shaft ends available upon request.

Specification Table⇒ **A-4-111**



Build-to-order LM Shafts

LM Shaft End Support Model SK

A lightweight aluminum fulcrum for securing an LM shaft.

Allows the LM shaft to be secured without having to machine the LM shaft ends.

Specification Table⇒ **A-4-108**

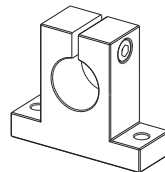

LM Shaft End Support Model SK

Classification Table

Linear Bushing

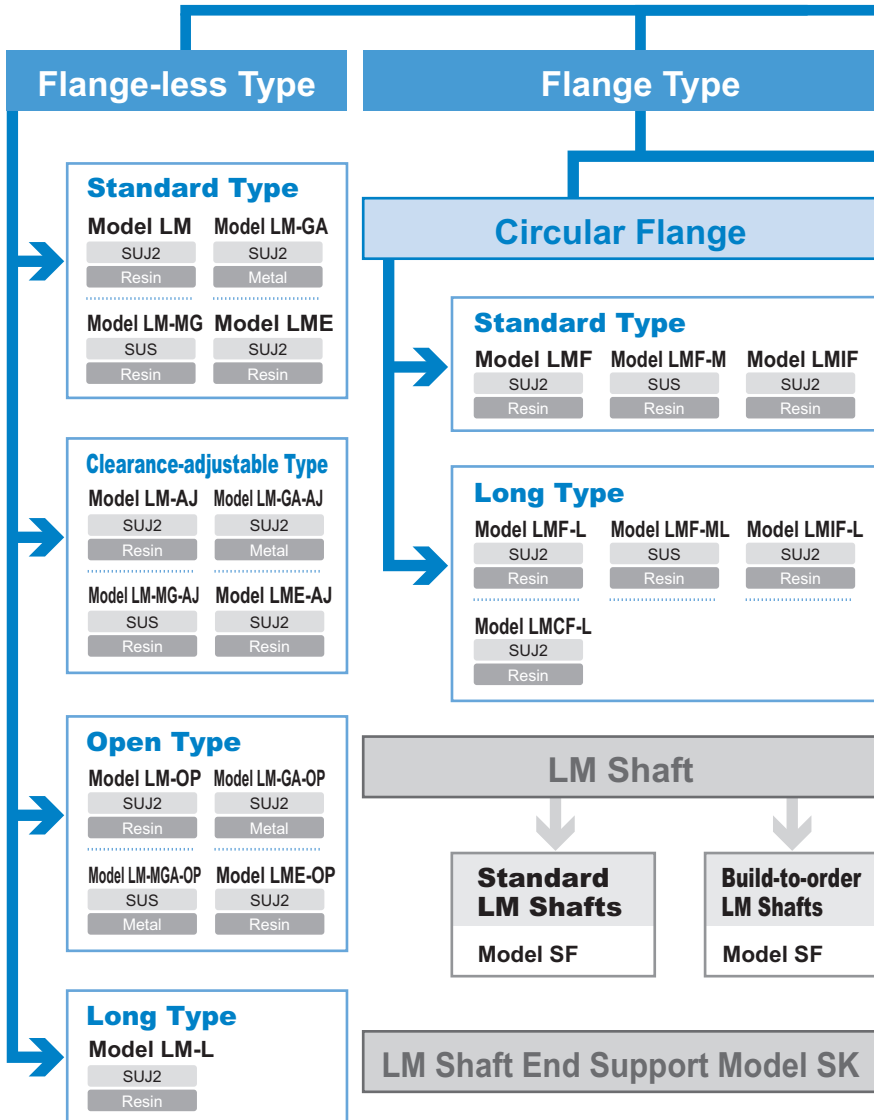

Features and Types

Classification Table

Type of Material

Model No.

- Nut Material
 - SUJ2 (High-carbon Chromium Bearing Steel)
 - SUS (Martensite Stainless Steel)
- Retainer Material
- Case Material

Square Flange

Standard Type

Model LMK	Model LMK-M
SUJ2	SUS
Resin	Resin
.....	
NEW	
Model LMIK	Model LMJK
SUJ2	SUJ2, Resin
Resin	Resin

Long Type

Model LMK-L	Model LMK-ML
SUJ2	SUS
Resin	Resin
.....	
Model LMIK-L	Model LMCK-L
SUJ2	SUJ2
Resin	Resin
.....	
NEW	
Model LMJK-L	
SUJ2, Resin	
Resin	

Cut Flange

Standard Type

Model LMH

SUJ2

Resin

.....

Model LMH-M

SUS

Resin

.....

Model LMIH

SUJ2

Resin

Long Type

Model LMH-L

SUJ2

Resin

.....

Model LMH-ML

SUS

Resin

.....

Model LMIH-L

SUJ2

Resin

.....

Model LMCH-L

SUJ2

Resin

Encased Type

Standard Type

Model SC

SUJ2

Resin

Aluminum

.....

Model SH

SUJ2

Resin

Aluminum

Long Type

Model SL

SUJ2

Resin

Aluminum

.....

Model SH-L

SUJ2

Resin

Aluminum

Flowchart for Selecting a Linear Bushing

Steps for Selecting a Linear Bushing

The following flowchart should be used as a guide for selecting a Linear Bushing.

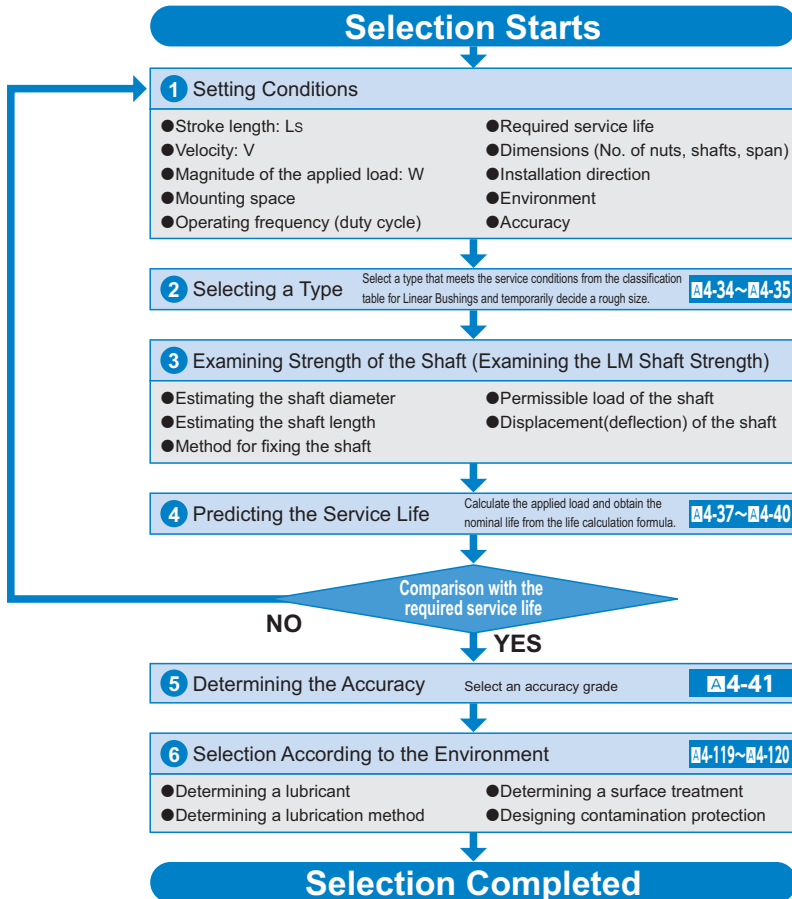





Rated Load and Nominal Life

[Load Rating]

The rated load of the Linear Bushing varies according to the position of balls in relation to the load direction. The basic load ratings indicated in the specification tables each indicate the value when one row of balls receiving a load are directly under the load.

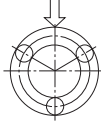
If the Linear Bushing is mounted so that two rows of balls evenly receive the load in the load direction, the rated load changes as shown in Table1.

Table1 Rated load of the Linear Bushing

Rows of balls	Ball position	Load Rating
3 rows		$1 \times C$
4 rows		$1.41 \times C$
5 rows		$1.46 \times C$
6 rows		$1.28 \times C$
8 rows		$1.25 \times C$

For specific values for "C" above, see the respective specification table.

[Calculating the Nominal Life]

The nominal life of the THK linear bushing is defined as 50 km. The nominal life (L_{10}) is calculated from the basic dynamic load rating (C) and the load acting on the linear bushing (P_c) using the following formula.

$$L_{10} = \left(\frac{C}{P_c} \right)^3 \times 50 \quad \dots\dots\dots(1)$$

L_{10}	: Nominal life	(km)
C	: Basic dynamic load rating	(N)
P_c	: Calculated load	(N)

*This nominal life formula may not apply if the length of the stroke is less than or equal to twice the length of the nut.

When comparing the nominal life (L_{10}), you must take into account whether the basic dynamic load rating was defined based on 50 km or 100 km. Convert the basic dynamic load rating based on ISO 14728-1 as necessary.

ISO-regulated basic dynamic load rating conversion formula:

$$C_{100} = \frac{C_{50}}{1.26}$$

C_{50}	: Basic dynamic load rating based on a nominal life of 50 km
C_{100}	: Basic dynamic load rating based on a nominal life of 100 km

[Calculating the Modified Nominal Life]

During use, a linear bushing may be subjected to vibrations and shocks as well as fluctuating loads, which are difficult to detect. In addition, the surface hardness of the raceways, the operating temperature, and having blocks arranged directly behind one another will have a decisive impact on the service life. Taking these factors into account, the modified nominal life (L_{10m}) can be calculated according to the following formula (2).

•Modified factor α

$$\alpha = \frac{f_H \cdot f_T \cdot f_C}{f_W}$$

α	: Modified factor	
f_H	: Hardness factor	(see Fig.1 on A4-39)
f_T	: Temperature factor	(see Fig.2 on A4-39)
f_C	: Contact factor	(see Table2 on A4-40)
f_W	: Load factor	(see Table 3 on A4-40)

•Modified nominal life L_{10m}

$$L_{10m} = \left(\alpha \times \frac{C}{P_c} \right)^3 \times 50 \quad \dots\dots\dots(2)$$

L_{10m}	: Modified nominal life	(km)
C	: Basic dynamic load rating	(N)
P_c	: Calculated load	(N)

● **When a Moment Load is Applied to a Single Nut or Two Nuts in Close Contact with Each Other**

When a moment load is applied to a single nut or two nuts in close contact with each other, calculate the equivalent radial load at the time the moment is applied.

$$P_v = K \cdot M$$

P_v : Equivalent radial load (N)
(with a moment applied)

K : Equivalent factors
(see Table4 to Table6 on **A4-41**)

M : Applied moment (N·mm)

However, " P_v " is assumed to be within the basic static load rating (C_0).

● **When a Moment Load and a Radial Load are Simultaneously Applied**

When a moment and a radial load are applied simultaneously, calculate the service life based on the sum of the radial load and the equivalent radial load.

■ **f_H : Hardness Factor**

To maximize the load capacity of the Linear Bushing, the hardness of the raceways needs to be between 58 to 64 HRC.

If the hardness is lower than this range, the basic dynamic load rating and the basic static load rating decrease. Therefore, it is necessary to multiply each rating by the respective hardness factor (f_H).

Normally, $f_H = 1.0$ since the Linear Bushing has sufficient hardness.

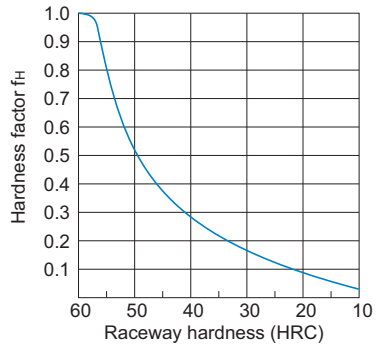

Fig.1 Hardness Factor (f_H)

■ **f_T : Temperature Factor**

If the temperature of the environment surrounding the operating Linear Bushing exceeds 100°C, take into account the adverse effect of the high temperature and multiply the basic load ratings by the temperature factor indicated in Fig.2.

Also note that the Linear Bushing itself must be of high temperature type.

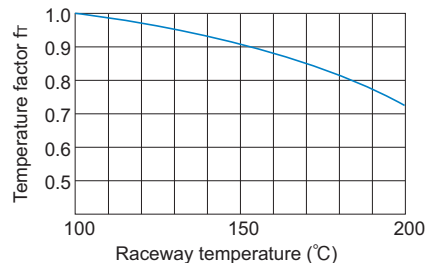

Fig.2 Temperature Factor (f_T)

Note) If the environment temperature exceeds 80°C, use a Linear Bushing type equipped with metal retainer plates.

■ f_c : Contact Factor

When multiple nuts are used in close contact with each other, their linear motion is affected by moments and mounting accuracy, making it difficult to achieve uniform load distribution. In such applications, multiply the basic load rating (C) and (C₀) by the corresponding contact factor in Table2.

Note) If uneven load distribution is expected in a large machine, take into account the respective contact factor indicated in Table2.

Table2 Contact Factor (f_c)

Number of nuts in close contact with each other	Contact factor f_c
2	0.81
3	0.72
4	0.66
5	0.61
Normal use	1

■ f_w : Load Factor

In general, reciprocating machines tend to experience vibrations or impacts during operation, and it is extremely difficult to accurately determine the vibrations generated during high-speed operation and impacts during frequent starts and stops. Therefore, when the actual load applied to a linear bushing cannot be obtained, or when speed and impacts have a significant influence, divide the basic dynamic load rating (C) by the corresponding load factor in Table 3, which has been empirically obtained.

Table 3 Load Factor (f_w)

Vibrations/ impact	Speed(V)	f_w
Faint	Very low $V \leq 0.25\text{m/s}$	1 to 1.2
Weak	Slow $0.25 < V \leq 1\text{m/s}$	1.2 to 1.5
Medium	Medium $1 < V \leq 2\text{m/s}$	1.5 to 2
Strong	High $V > 2\text{m/s}$	2 to 3.5

[Calculating the Service Life Time]

When the nominal life (L_{10}) has been obtained, if the stroke length and the number of reciprocations per minute are constant, the service life time is obtained using the following equation.

$$L_h = \frac{L_{10} \times 10^3}{2 \times \ell_s \times n_1 \times 60}$$

L_h : Service life time (h)

ℓ_s : Stroke length (m)

n_1 : Number of reciprocations per minute (min^{-1})

Table of Equivalent Factors

Table4 Equivalent Factors of Model LM

Model No.	Equivalent factor: K	
	Single nut	Double blocks
LM 3	1.566	0.26
LM 4	1.566	0.21
LM 5	1.253	0.178
LM 6	0.553	0.162
LM 8S	0.708	0.166
LM 8	0.442	0.128
LM 10	0.389	0.101
LM 12	0.389	0.097
LM 13	0.343	0.093
LM 16	0.279	0.084
LM 20	0.257	0.071
LM 25	0.163	0.054
LM 30	0.153	0.049
LM 35	0.143	0.045
LM 38	0.127	0.042
LM 40	0.117	0.04
LM 50	0.096	0.032
LM 60	0.093	0.028
LM 80	0.077	0.022
LM 100	0.065	0.017
LM 120	0.051	0.015

Note) Equivalent factors for the following models are the same as for model LM: Models LMF, LMK, LMIF, LMIK, LMIH, LMH, and SC.

Table5 Equivalent Factors of Model LM-L

Model No.	Equivalent factor: K
	Single nut
LM 3L	0.654
LM 4L	0.578
LM 5L	0.446
LM 6L	0.402
LM 8L	0.302
LM 10L	0.236
LM 12L	0.226
LM 13L	0.214
LM 16L	0.192
LM 20L	0.164
LM 25L	0.12
LM 30L	0.106
LM 35L	0.1
LM 40L	0.086
LM 50L	0.068
LM 60L	0.062

Note) Equivalent factors for the following models are the same as for model LM-L: Models LMF-L, LMK-L, LMH-L, LMIF-L, LMIK-L, LMIH-L, LMCF-L, LMCK-L, and LMCH-L.

Table6 Equivalent Factors of Model LME

Model No.	Equivalent factor: K	
	Single nut	Double blocks
LME 5	0.669	0.123
LME 8	0.514	0.116
LME 12	0.389	0.09
LME 16	0.343	0.081
LME 20	0.291	0.063
LME 25	0.209	0.052
LME 30	0.167	0.045
LME 40	0.127	0.039
LME 50	0.105	0.031
LME 60	0.093	0.024
LME 80	0.077	0.018

Precautions To Be Taken if an Eccentric Load Is Applied

Since Linear Bushing is not suitable for application of an eccentric load, we recommend using Guide Ball Bushing or Ball Spline.

Accuracy Standards

[Linear Bushing]

The accuracy of the Linear Bushing in inscribed bore diameter, outer diameter, width and eccentricity is described in the corresponding specification table. The accuracy of mode LM in inscribed bore diameter and eccentricity is classified into high accuracy grade (no symbol) and precision grade (P). (Accuracy symbol is expressed at the end of the model number.)

For the clearance-adjustable type (-AJ) and open type (-OP), the inscribed bore diameter tolerance, the outer diameter tolerance, and the eccentricity indicate the values before the division of the nut.

Model LM

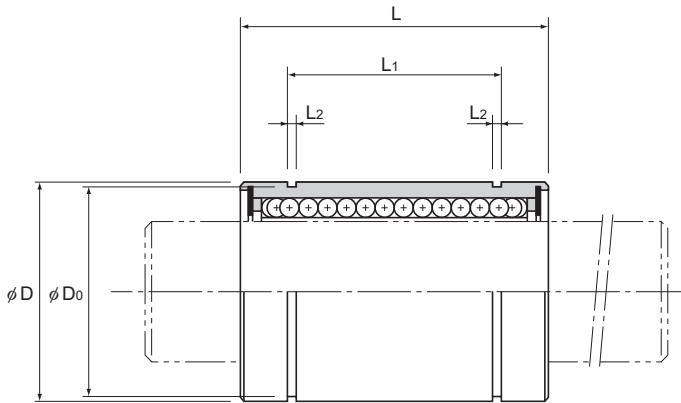

Model No.			Ball rows	Main						
Standard type	Clearance-adjustable type	Open type		Inscribed bore diameter		Outer diameter		Length		
				dr	Tolerance		D	Tolerance	L	Tolerance
				High	Precision	High/Precision				
LM 3	—	—	4	3			7		10	
LM 4	—	—	4	4	0	0	8	0	12	0
LM 5	—	—	4	5	-0.008	-0.005	10	-0.009	15	-0.12
LM 6	LM 6-AJ	—	4	6			12		19	
LM 8S	LM 8S-AJ	—	4	8			15	0	17	
LM 8	LM 8-AJ	—	4	8			15	-0.011	24	
LM 10	LM 10-AJ	—	4	10	0	0	19		29	0
LM 12	LM 12-AJ	—	4	12	-0.009	-0.006	21	0	30	-0.2
LM 13	LM 13-AJ	LM 13-OP	4	13			23	-0.013	32	
LM 16	LM 16-AJ	LM 16-OP	5	16			28		37	
LM 20	LM 20-AJ	LM 20-OP	5	20			32		42	
LM 25	LM 25-AJ	LM 25-OP	6	25	0	0	40	0	59	
LM 30	LM 30-AJ	LM 30-OP	6	30	-0.010	-0.007	45	-0.016	64	
LM 35	LM 35-AJ	LM 35-OP	6	35			52	0	70	
LM 40	LM 40-AJ	LM 40-OP	6	40	0	0	60	0	80	0
LM 50	LM 50-AJ	LM 50-OP	6	50	-0.012	-0.008	80	-0.019	100	-0.3
LM 60	LM 60-AJ	LM 60-OP	6	60	0	0	90	0	110	
					-0.015	-0.009		-0.022		

Note) Since this model contains a synthetic resin retainer, do not use it at temperature exceeding 80°C.

If the ambient temperature exceeds 80°C, use the type equipped with a metal retainer (model LM-GA).

If requiring a type equipped with a seal, indicate it when placing an order.

(Example) LM13 UU

————— Seal attached on both ends of the nut

For the clearance-adjustable type (-AJ) and open type (-OP), the inscribed bore diameter tolerance, the outer diameter tolerance, and the eccentricity indicate the values before the division of the nut.

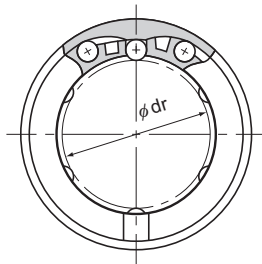

Model LM

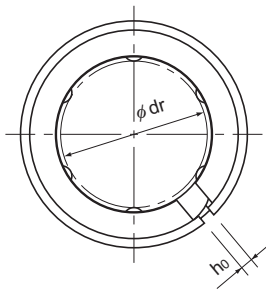

Model LM-AJ

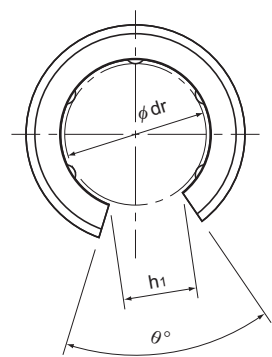

Model LM-OP

Unit: mm

dimensions								Eccentricity (max) μm		Radial clearance tolerance μm	Basic load rating		
L_1	Tolerance	L_2	D_0	h_0	h_1	θ°	High	Precision	C N		C_0 N	Mass g	
—	—	—	—	—	—	—	8	4	-2	88.2	108	1.6	
—	—	—	—	—	—	—	8	4	-3	88.2	127	2.2	
10.2	0 -0.2	1.1	9.6	—	—	—	8	4	-3	167	206	4	
13.5		1.1	11.5	1	—	—	12	8	-5	206	265	8	
11.5		1.1	14.3	1	—	—	12	8	-5	176	225	9.3	
17.5		1.1	14.3	1	—	—	12	8	-5	265	402	13.5	
22		1.3	18	1	—	—	12	8	-5	373	549	25	
23		1.3	20	1.5	—	—	12	8	-5	412	598	28	
23		1.3	22	1.5	9	80	12	8	-7	510	775	38	
26.5		1.6	27	1.5	11	60	12	8	-7	775	1180	78	
30.5		1.6	30.5	1.5	11	60	15	10	-9	863	1370	86	
41		1.85	38	2	12	50	15	10	-9	980	1570	210	
44.5	1.85	43	2.5	15	50	15	10	-9	1570	2750	221		
49.5	2.1	49	2.5	17	50	20	12	-13	1670	3140	358		
60.5	2.1	57	3	20	50	20	12	-13	2160	4020	557		
74	2.6	76.5	3	25	50	20	12	-13	3820	7940	1418		
85	3.15	86.5	3	30	50	25	17	-16	4710	10000	1733		

Note) When using the Linear Bushing on a single shaft, use two or more units (instead of one unit) on the same shaft to avoid a moment load, and secure a large distance between the units.

If an oil hole is required, this can be indicated by appending "OH" to the end of the model number.

For further information, contact THK.

Model LM-GA (Metal Retainer Type)

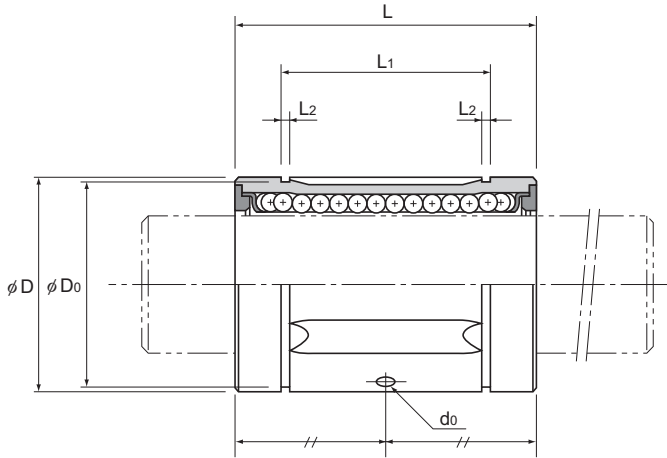

Model No.			Ball rows	Main							
Standard type	Clearance-adjustable type	Open type		Inscribed bore diameter		Outer diameter		Length			
				dr	Tolerance		D	Tolerance High/Precision	L	Tolerance	
LM 6GA	—	—	3	6	0	0	12	0	19	-0.2	
LM 8SGA	—	—	3	8			15		-0.011		17
LM 8GA	—	—	3	8			15				24
LM 10GA	—	—	4	10			19	0	29		
LM 12GA	LM 12GA-AJ	LM 12GA-OP	4	12			21		-0.013		30
LM 13GA	LM 13GA-AJ	LM 13GA-OP	4	13			23				32
LM 16GA	LM 16GA-AJ	LM 16GA-OP	4	16	28	37					
LM 20GA	LM 20GA-AJ	LM 20GA-OP	5	20	32	0	42				
LM 25GA	LM 25GA-AJ	LM 25GA-OP	5	25	40	-0.016	59	-0.3			
LM 30GA	LM 30GA-AJ	LM 30GA-OP	6	30	45		64				
LM 35GA	LM 35GA-AJ	LM 35GA-OP	6	35	52	0	70				
LM 38GA	LM 38GA-AJ	LM 38GA-OP	6	38	57	-0.019	76				
LM 40GA	LM 40GA-AJ	LM 40GA-OP	6	40	60		80				
LM 50GA	LM 50GA-AJ	LM 50GA-OP	6	50	80	0	100				
LM 60GA	LM 60GA-AJ	LM 60GA-OP	6	60	90	-0.022	110				
LM 80GA	LM 80GA-AJ	LM 80GA-OP	6	80	120		140				
LM 100GA	LM 100GA-AJ	LM 100GA-OP	6	100	150	0	175		-0.4		
LM 120A	LM 120A-AJ	LM 120A-OP	8	120	180	-0.025	200				

Note) If requiring a type equipped with a seal, indicate it when placing an order. (seal heat resistance: 80°C.)

(Example) LM50GA UU

Seal attached on both ends of the nut

For the clearance-adjustable type (-AJ) and open type (-OP), the inscribed bore diameter tolerance, the outer diameter tolerance, and the eccentricity indicate the values before the division of the nut.

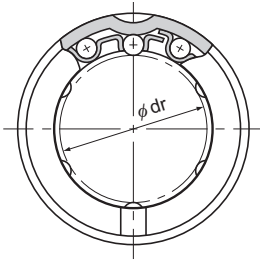

Model LM-GA

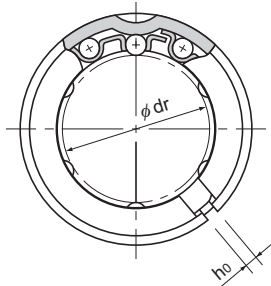

Model LM-GA-AJ

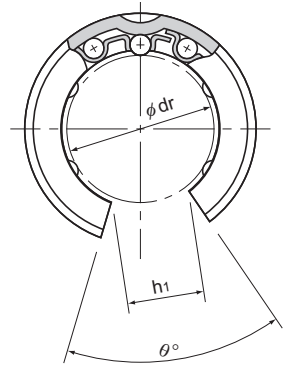

Model LM-GA-OP

Unit: mm

dimensions								Greasing hole d _o	Eccentricity (max) μm		Radial clearance tolerance μm	Basic load rating		Mass g
L ₁	Tolerance	L ₂	D _o	h _o	h ₁	θ°	High		Precision	C N		C ₀ N		
13.5	0 -0.2	1.1	11.5	—	—	—	—	12	8	-5	206	265	7	
11.5		1.1	14.3	—	—	—	—	12	8	-5	176	225	10	
17.5		1.1	14.3	—	—	—	—	12	8	-5	265	402	14	
22		1.3	18	—	—	—	—	2	12	8	-5	373	549	27
23		1.3	20	1.5	7.5	80	2	12	8	-5	412	598	31	
23		1.3	22	1.5	9	80	2	12	8	-7	510	775	41	
26.5		1.6	27	1.5	11	60	2.3	12	8	-7	775	1180	69	
30.5		1.6	30.5	2	11	60	2.3	15	10	-9	863	1370	92	
41	0 -0.3	1.85	38	2	13	60	3	15	10	-9	980	1570	200	
44.5		1.85	43	2.5	15	50	3	15	10	-9	1570	2750	250	
49.5		2.1	49	2.5	17	50	3	20	12	-13	1670	3140	370	
58.5		2.1	54.5	3	18	50	3	20	12	-13	2160	4020	490	
60.5		2.1	57	3	20	50	3	20	12	-13	2160	4020	590	
74		2.6	76.5	3	25	50	4	20	12	-13	3820	7940	1500	
85		3.15	86.5	3	30	50	4	25	17	-16	4710	10000	1850	
105.5		0 -0.4	4.15	116	3	40	50	4	25	17	-16	7350	16000	4200
125.5	4.15		145	3	50	50	4	30	20	-20	14100	34800	8200	
158.6	4.15		175	4	85	80	5	30	20	-25	16400	40000	15500	

Note) When using the Linear Bushing on a single shaft, use two or more bushings on the same shaft to minimize a moment load, and secure a large distance between the units.

Model LM-GA has oil holes as a standard feature.

If an oil hole is required, this can be indicated by appending "OH" to the end of the model number.

For further information, contact THK.

Model LM-MG (Stainless Steel Type)

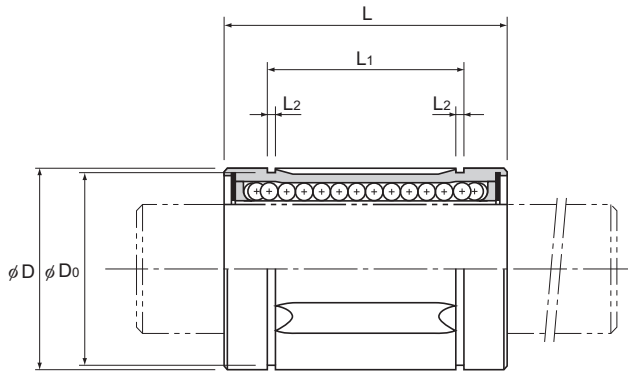

Model No.			Ball rows	Main									
Standard type	Clearance-adjustable type	Open type		Inscribed bore diameter		Outer diameter		Length					
				dr	Tolerance		D	Tolerance	L	Tolerance			
LM 3M	—	—	4	3	0	0	7	0	10	0			
LM 4M	—	—	4	4			8		12		-0.009	15	-0.12
LM 5M	—	—	4	5			10		15				
* LM 6MG	LM 6MG-AJ	—	4	6	0	0	12	0	19	-0.2			
* LM 8SMG	LM 8SMG-AJ	—	4	8			15		17		-0.011	24	
* LM 8MG	* LM 8MG-AJ	—	4	8			15		24				
* LM 10MG	* LM 10MG-AJ	—	4	10			19	29	0		30	0	
* LM 12MG	* LM 12MG-AJ	—	4	12			21	30					
* LM 13MG	* LM 13MG-AJ	* LM13MGA-OP	4	13			23	32	-0.013		37	-0.3	
* LM 16MG	* LM 16MG-AJ	* LM16MGA-OP	4	16	28	37							
* LM 20MG	* LM 20MG-AJ	* LM20MGA-OP	5	20	32	42	0	59	0				
* LM 25MG	* LM 25MG-AJ	* LM25MGA-OP	5	25	40	59							
* LM 30MG	* LM 30MG-AJ	* LM30MGA-OP	6	30	45	64	-0.016	70	0				
* LM 35MG	* LM 35MG-AJ	* LM35MGA-OP	6	35	52	70							
* LM 40MG	* LM 40MG-AJ	* LM40MGA-OP	6	40	60	80	-0.019	80	-0.3				

Note) Since this model contains a synthetic resin retainer, do not use it at temperature exceeding 80°C.

If the ambient temperature exceeds 80°C, use the type equipped with a metal retainer and indicate "A" at the end of the model number.

(For those marked with * in the table, metal retainers are available. Only metal retainer is available for open type.)

(Metal retainer types of models LM6MG, 8SMG and 8MG each have 3 rows of balls.)

(Example) LM30MG A

High temperature symbol

If requiring a type equipped with a seal, indicate it when placing an order. (seal heat resistance: 80°C.)

(Example) LM30MG UU

Seal attached on both ends of the nut

For the clearance-adjustable type (-AJ) and open type (-OP), the inscribed bore diameter tolerance, the outer diameter tolerance, and the eccentricity indicate the values before the division of the nut.

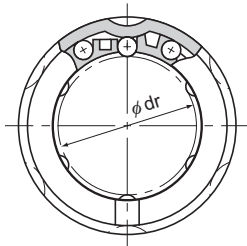

Model LM-MG

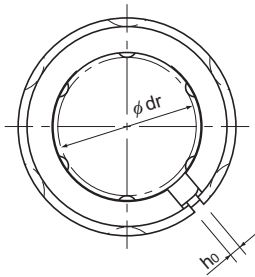

Model LM-MG-AJ

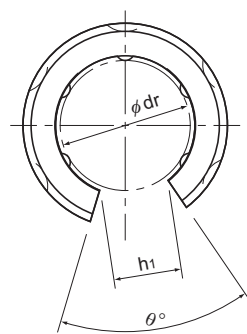

Model LM-MG-OP

Unit: mm

dimensions								Eccentricity (max) μm		Radial clearance tolerance μm	Basic load rating		
L ₁	Tolerance	L ₂	D ₀	h ₀	h ₁	θ°	High	Precision	C N		C ₀ N	Mass g	
—	—	—	—	—	—	—	8	4	-2	88.2	108	1.6	
—	—	—	—	—	—	—	8	4	-3	88.2	127	2.2	
10.2	-0.2	1.1	9.6	—	—	—	8	4	-3	167	206	4	
13.5		1.1	11.5	1	—	—	12	8	-5	206	265	6	
11.5		1.1	14.3	1	—	—	12	8	-5	176	225	9	
17.5		1.1	14.3	1	—	—	12	8	-5	265	402	13	
22		1.3	18	1	—	—	12	8	-5	373	549	23	
23		1.3	20	1.5	—	—	12	8	-5	412	598	27	
23		1.3	22	1.5	9	80	12	8	-7	510	775	35	
26.5		1.6	27	1.5	11	80	12	8	-7	775	1180	59	
30.5		1.6	30.5	1.5	11	60	15	10	-9	863	1370	79	
41		-0.3	1.85	38	2	12	50	15	10	-9	980	1570	170
44.5	1.85		43	2.5	15	50	15	10	-9	1570	2750	220	
49.5	2.1		49	2.5	17	50	20	12	-13	1670	3140	330	
60.5	2.1		57	3	20	50	20	12	-13	2160	4020	530	

Note) Since the nut and the balls use stainless steel, these models are highly resistant to corrosion and environment.

If an oil hole is required, this can be indicated by appending "OH" to the end of the model number.

For further information, contact THK.

When using the Linear Bushing on a single shaft, use two or more bushings on the same shaft to minimize a moment load, and secure a large distance between the units.

Model LME

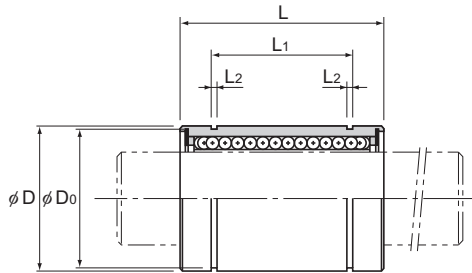

Model No.			Ball rows	Main					
Standard type	Clearance-adjustable type	Open type		Inscribed bore diameter		Outer diameter		Length	
				dr	Tolerance	D	Tolerance	L	Tolerance
LME 5	LME 5-AJ	—	4	5	+0.008 0	12	0	22	0 -0.2
LME 8	LME 8-AJ	—	4	8		16	-0.008	25	
LME 12	LME 12-AJ	—	4	12		22	0	32	
LME 16	LME 16-AJ	LME 16-OP	5	16	+0.009	26	-0.009	36	0 -0.3
LME 20	LME 20-AJ	LME 20-OP	5	20	-0.001	32	0	45	
LME 25	LME 25-AJ	LME 25-OP	6	25	+0.011	40	-0.011	58	
LME 30	LME 30-AJ	LME 30-OP	6	30	-0.001	47	0	68	0 -0.3
LME 40	LME 40-AJ	LME 40-OP	6	40	62	0	80		
LME 50	LME 50-AJ	LME 50-OP	6	50	+0.013 -0.002	75 90	-0.013	100 125	
LME 60	LME 60-AJ	LME 60-OP	6	60	+0.016 -0.004	120	0 -0.015	165	0 -0.4
LME 80GA	LME 80GA-AJ	LME 80GA-OP	6	80					

Note) Since Linear Bushing models LME60 or smaller models are incorporated with a synthetic resin retainer, do not use them at temperature exceeding 80°C.

If the ambient temperature exceeds 80°C, use the type equipped with a metal retainer and indicate "A" at the end of the model number.

(Example) LME20G A

High temperature symbol

If requiring a type equipped with a seal, indicate it when placing an order. (seal heat resistance: 80°C.)

(Example) LME16 UU

Seal attached on both ends of the nut

For the clearance-adjustable type (-AJ) and open type (-OP), the inscribed bore diameter tolerance, the outer diameter tolerance, and the eccentricity indicate the values before the division of the nut.

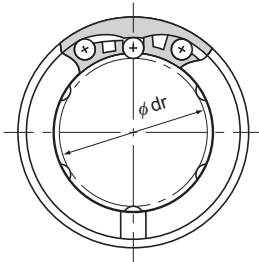

Model LME

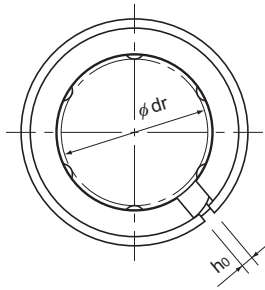

Model LME-AJ

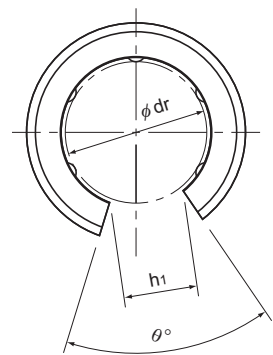

Model LME-OP

Unit: mm

dimensions								Eccentricity (max)	Radial clearance tolerance	Basic load rating		Mass g
L_1	Tolerance	L_2	D_0	h_0	h_1	θ°	μm			μm	C N	
14.5	0 -0.2	1.1	11.5	1	—	—	12	-5	206	265	11.4	
16.5		1.1	15.2	1	—	—	12	-5	265	402	18.5	
22.9		1.3	21	1.5	7.5	78	12	-7	510	775	37	
24.9		1.3	24.9	1.5	10	78	12	-7	775	1180	52	
31.5		1.6	30.3	2	10	60	15	-9	863	1370	89	
44.1	0 -0.3	1.85	37.5	2	12.5	60	15	-9	980	1570	203	
52.1		1.85	44.5	2	12.5	50	15	-9	1570	2750	306	
60.6		2.15	59	3	16.8	50	17	-13	2160	4020	673	
77.6		2.65	72	3	21	50	17	-13	3820	7940	1025	
101.7	0 -0.4	3.15	86.5	3	27.2	54	20	-16	4710	10000	1914	
133.7		4.15	116	3	36.3	54	20	-16	7350	16000	4800	

Note) If a metal retainer is used, the Linear Bushing has the shape as shown below.

When using the Linear Bushing on a single shaft, use two or more units (instead of one unit) on the same shaft to avoid a moment load, and secure a large distance between the units.

If an oil hole is required, this can be indicated by appending "OH" to the end of the model number.

For further information, contact THK.



Model LME-GA

Model LM-L

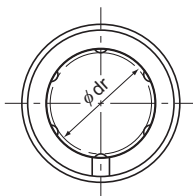

Model LM-L

Model No. Standard type	Ball rows	Main					
		Inscribed bore diameter		Outer diameter		Length	
		dr	Tolerance	D	Tolerance	L	Tolerance
LM 3L	4	3	0 -0.010	7	0 -0.013	19	0 -0.3
LM 4L	4	4		8		23	
LM 5L	4	5		10		29	
LM 6L	4	6		12		35	
LM 8L	4	8		15		45	
LM 10L	4	10		19	55		
LM 12L	4	12		21	0 -0.016	57	
LM 13L	4	13		23	61		
LM 16L	5	16		28	70		
LM 20L	5	20		32	80		
LM 25L	6	25	0 -0.012	40	0 -0.019	112	0 -0.4
LM 30L	6	30	45	123			
LM 35L	6	35	52	135			
LM 40L	6	40	0 -0.015	60	0 -0.022	154	
LM 50L	6	50	80	192			
LM 60L	6	60	0 -0.020	90	0 -0.025	211	

Note) Since this model contains a synthetic resin retainer, do not use it at temperature exceeding 80°C.
If requiring a type equipped with a seal, indicate it when placing an order.

(Example) LM13L UU

└── Seal attached on both ends of the nut

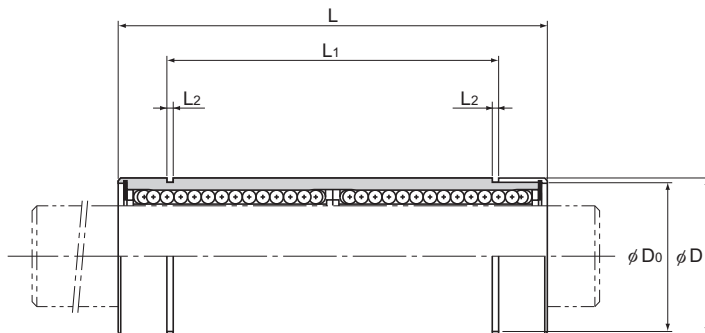

Unit: mm

dimensions					Eccentricity (max) μm	Radial clearance tolerance μm	Basic load rating		Mass g
L ₁	Tolerance	L ₂	D ₀	C N			C ₀ N		
—	—	—	—	10	-2	139	216	3	
—		—	—	10	-3	139	254	4	
20	0 -0.3	1.1	9.6	10	-3	263	412	10	
27		1.1	11.5	15	-5	324	529	15	
35		1.1	14.3	15	-5	431	784	26	
44		1.3	18	15	-5	588	1100	48	
46		1.3	20	15	-5	657	1200	56	
46		1.3	22	15	-7	814	1570	75	
53		1.6	27	15	-7	1230	2350	147	
61		1.6	30.5	20	-9	1400	2750	163	
82		0 -0.4	1.85	38	20	-9	1560	3140	397
89			1.85	43	20	-9	2490	5490	434
99	2.1		49	25	-13	2650	6270	696	
121	2.1		57	25	-13	3430	8040	1087	
148	2.6		76.5	25	-13	6080	15900	2770	
170	3.15		86.5	25	-16	7650	20000	3340	

Note) A stainless steel type (LM3ML to 30ML) is also available. Contact THK for details.

If an oil hole is required, this can be indicated by appending "OH" to the end of the model number.

For further information, contact THK.

Model LMF

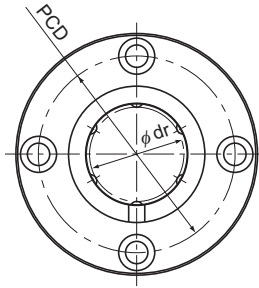

Model LMF

Model No.	Ball rows	Main dimensions							
		Inscribed bore diameter		Outer diameter		Length		Flange diameter	
		dr	Tolerance	D	Tolerance	L	Tolerance	D_1	Tolerance
LMF 6	4	6	0 -0.009	12	0 -0.011	19	0 -0.2	28	0 -0.2
LMF 8S	4	8		15		17		32	
LMF 8	4	8		15	24	32			
LMF 10	4	10		19	29	39			
LMF 12	4	12	21	0 -0.013	30	42			
LMF 13	4	13	23	32	43				
LMF 16	5	16	28	37	48				
LMF 20	5	20	32	42	54				
LMF 25	6	25	0 -0.010	40	0 -0.016	59	62		
LMF 30	6	30	45	64	74				
LMF 35	6	35	0	52	0	70	82		
LMF 40	6	40	-0.012	60	-0.019	80	96		
LMF 50	6	50	0	80	0	100	116		
LMF 60	6	60	0 -0.015	90	0 -0.022	110	134	0 -0.3	

Note) Since this model contains a synthetic resin retainer, do not use it at temperature exceeding 80°C.
If requiring a type equipped with a seal, indicate it when placing an order.

(Example) LMF25 UU

└────────── Seal attached on both ends of the nut

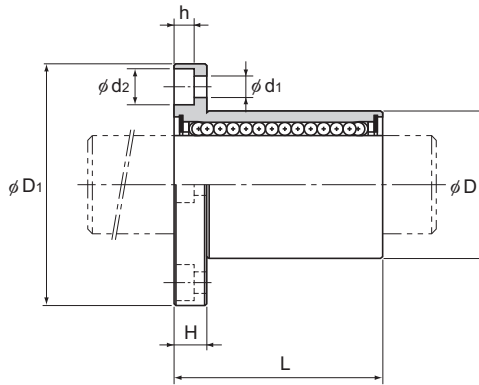

Unit: mm

	H	PCD	Mounting hole d ₁ × d ₂ × h	Flange perpendicularity	Eccentricity (max)	Radial clearance tolerance	Basic load rating		Mass g
				μm	μm	μm	C N	C ₀ N	
	5	20	3.4 × 6.5 × 3.3	12	12	-5	206	265	23
	5	24	3.4 × 6.5 × 3.3	12	12	-5	176	225	29
	5	24	3.4 × 6.5 × 3.3	12	12	-5	265	402	33
	6	29	4.5 × 8 × 4.4	12	12	-5	373	549	59
	6	32	4.5 × 8 × 4.4	12	12	-5	412	598	68
	6	33	4.5 × 8 × 4.4	12	12	-7	510	775	80
	6	38	4.5 × 8 × 4.4	12	12	-7	775	1180	126
	8	43	5.5 × 9.2 × 5.4	15	15	-9	863	1370	160
	8	51	5.5 × 9.2 × 5.4	15	15	-9	980	1570	305
	10	60	6.6 × 11 × 6.5	15	15	-9	1570	2750	422
	10	67	6.6 × 11 × 6.5	20	20	-13	1670	3140	583
	13	78	9 × 14 × 8.6	20	20	-13	2160	4020	960
	13	98	9 × 14 × 8.6	20	20	-13	3820	7940	1920
	18	112	11 × 17.5 × 10.8	25	25	-13	4710	10000	2720

Note) If an oil hole is required, this can be indicated by appending "OH" to the end of the model number.
For further information, contact THK.

Model LMF-M (Stainless Steel Type)

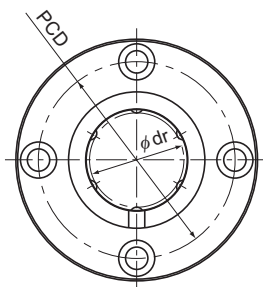

Model LMF-M

Model No.	Ball rows	Main dimensions							
		Inscribed bore diameter		Outer diameter		Length		Flange diameter	
		dr	Tolerance	D	Tolerance	L	Tolerance	D _f	Tolerance
LMF 6M	4	6	0 -0.009	12	0 -0.011	19	0 -0.2	28	0 -0.2
LMF 8SM	4	8		15		17		32	
LMF 8M	4	8		15	24	32			
LMF 10M	4	10		19	29	39			
LMF 12M	4	12	21	0 -0.013	30	42			
LMF 13M	4	13	23	32	43				
LMF 16M	5	16	28	37	48				
LMF 20M	5	20	32	0 -0.016	42	54			
LMF 25M	6	25	40	59	0 -0.3	62			
LMF 30M	6	30	45	64	74				

Note) Since this model contains a synthetic resin retainer, do not use it at temperature exceeding 80°C.
If requiring a type equipped with a seal, indicate it when placing an order.

(Example) LMF20M UU

└── Seal attached on both ends of the nut

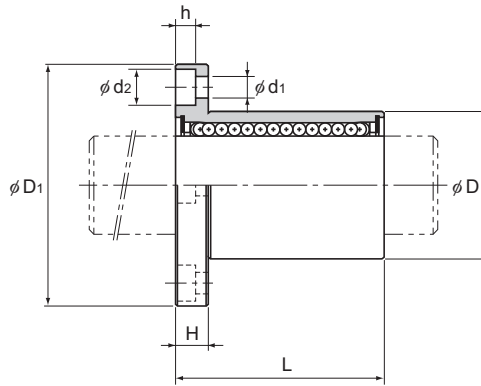

Unit: mm

	H	PCD	Mounting hole d ₁ × d ₂ × h	Flange perpendicularity	Eccentricity (max)	Radial clearance tolerance	Basic load rating		Mass g
				μm	μm	μm	C N	C ₀ N	
	5	20	3.4 × 6.5 × 3.3	12	12	-5	206	265	23
	5	24	3.4 × 6.5 × 3.3	12	12	-5	176	225	29
	5	24	3.4 × 6.5 × 3.3	12	12	-5	265	402	33
	6	29	4.5 × 8 × 4.4	12	12	-5	373	549	59
	6	32	4.5 × 8 × 4.4	12	12	-5	412	598	68
	6	33	4.5 × 8 × 4.4	12	12	-7	510	775	80
	6	38	4.5 × 8 × 4.4	12	12	-7	775	1180	126
	8	43	5.5 × 9.2 × 5.4	15	15	-9	863	1370	160
	8	51	5.5 × 9.2 × 5.4	15	15	-9	980	1570	305
	10	60	6.6 × 11 × 6.5	15	15	-9	1570	2750	422

Note) Since the nut and the balls use stainless steel, these models are highly resistant to corrosion and environment.
If an oil hole is required, this can be indicated by appending "OH" to the end of the model number.
For further information, contact THK.

Model LMF-L

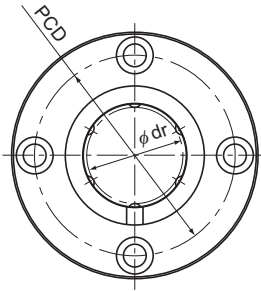

Model LMF-L

Model No. Standard type	Ball rows	Main dimensions							
		Inscribed bore diameter		Outer diameter		Length		Flange diameter	
		dr	Tolerance	D	Tolerance	L	Tolerance	D ₁	Tolerance
LMF 6L	4	6	0 -0.010	12	0	35	0 -0.3	28	0 -0.2
LMF 8L	4	8		15	-0.013	45		32	
LMF 10L	4	10		19	0 -0.016	55		39	
LMF 12L	4	12		21		57		42	
LMF 13L	4	13		23		61		43	
LMF 16L	5	16		28	70	48		0 -0.4	
LMF 20L	5	20	32	80	54				
LMF 25L	6	25	40	0 -0.019	112	62			
LMF 30L	6	30	45	123	74				
LMF 35L	6	35	52	135	82				
LMF 40L	6	40	0 -0.015	60	0 -0.022	154	96		
LMF 50L	6	50	80	192	116	0 -0.3			
LMF 60L	6	60	0 -0.020	90	0 -0.025		211	134	

Note) Since this model contains a synthetic resin retainer, do not use it at temperature exceeding 80°C.
If requiring a type equipped with a seal, indicate it when placing an order.

(Example) LMF35L UU

└─── Seal attached on both ends of the nut

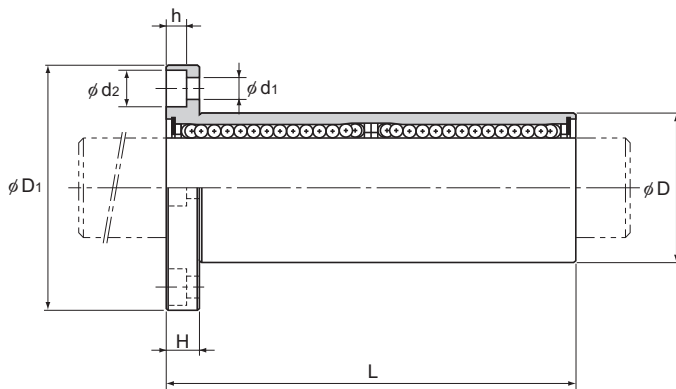

Unit: mm

	H	PCD	Mounting hole d ₁ × d ₂ × h	Flange perpendicularity	Eccentricity (max)	Radial clearance tolerance	Basic load rating		Mass g
				μm	μm	μm	C N	C ₀ N	
	5	20	3.4 × 6.5 × 3.3	15	15	-5	324	529	29
	5	24	3.4 × 6.5 × 3.3	15	15	-5	431	784	45
	6	29	4.5 × 8 × 4.4	15	15	-5	588	1100	81
	6	32	4.5 × 8 × 4.4	15	15	-5	657	1200	93
	6	33	4.5 × 8 × 4.4	15	15	-7	814	1570	115
	6	38	4.5 × 8 × 4.4	15	15	-7	1230	2350	194
	8	43	5.5 × 9.2 × 5.4	20	20	-9	1400	2750	250
	8	51	5.5 × 9.2 × 5.4	20	20	-9	1560	3140	500
	10	60	6.6 × 11 × 6.5	20	20	-9	2490	5490	646
	10	67	6.6 × 11 × 6.5	25	25	-13	2650	6270	930
	13	78	9 × 14 × 8.6	25	25	-13	3430	8040	1488
	13	98	9 × 14 × 8.6	25	25	-13	6080	15900	3268
	18	112	11 × 17.5 × 10.8	25	25	-13	7650	20000	4342

Note) If an oil hole is required, this can be indicated by appending "OH" to the end of the model number.
For further information, contact THK.

Model LMF-ML (Stainless Steel Type)

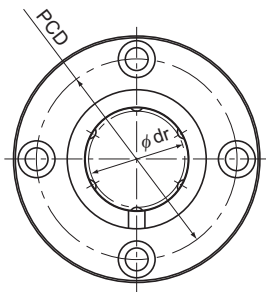

Model LMF-ML

Model No. Standard type	Ball rows	Main dimensions							
		Inscribed bore diameter		Outer diameter		Length		Flange diameter	
		dr	Tolerance	D	Tolerance	L	Tolerance	D ₁	Tolerance
LMF 6ML	4	6	0 -0.010	12	0	35	0 -0.3	28	0 -0.2
LMF 8ML	4	8		15	-0.013	45		32	
LMF 10ML	4	10		19	0 -0.016	55		39	
LMF 12ML	4	12		21		57		42	
LMF 13ML	4	13	23	0 -0.019	61	43			
LMF 16ML	5	16	28		70	48			
LMF 20ML	5	20	32	0 -0.012	80	54			
LMF 25ML	6	25	40		112	0	62		
LMF 30ML	6	30	45		123	-0.4	74		

Note) Since this model contains a synthetic resin retainer, do not use it at temperature exceeding 80°C.
If requiring a type equipped with a seal, indicate it when placing an order.

(Example) LMF13ML UU

└── Seal attached on both ends of the nut

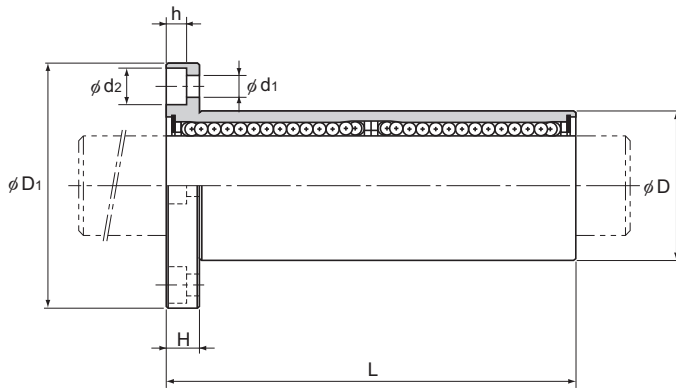

Unit: mm

	H	PCD	Mounting hole d ₁ × d ₂ × h	Flange perpendicularity	Eccentricity (max)	Radial clearance tolerance	Basic load rating		Mass g
				μm	μm	μm	C N	C ₀ N	
	5	20	3.4 × 6.5 × 3.3	15	15	-5	324	529	29
	5	24	3.4 × 6.5 × 3.3	15	15	-5	431	784	45
	6	29	4.5 × 8 × 4.4	15	15	-5	588	1100	81
	6	32	4.5 × 8 × 4.4	15	15	-5	657	1200	93
	6	33	4.5 × 8 × 4.4	15	15	-7	814	1570	115
	6	38	4.5 × 8 × 4.4	15	15	-7	1230	2350	194
	8	43	5.5 × 9.2 × 5.4	20	20	-9	1400	2750	250
	8	51	5.5 × 9.2 × 5.4	20	20	-9	1560	3140	500
	10	60	6.6 × 11 × 6.5	20	20	-9	2490	5490	646

Note) Since the nut and the balls use stainless steel, these models are highly resistant to corrosion and environment.
If an oil hole is required, this can be indicated by appending "OH" to the end of the model number.
For further information, contact THK.

Model LMK

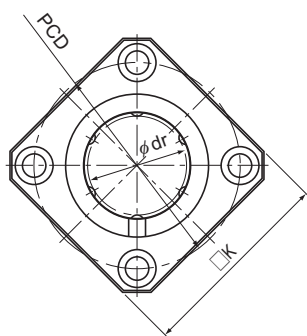

Model LMK

Model No.	Ball rows	Main dimensions							
		Inscribed bore diameter		Outer diameter		Length		Flange diameter	
		dr	Tolerance	D	Tolerance	L	Tolerance	D_i	Tolerance
LMK 6	4	6	0 -0.009	12	0 -0.011	19	0 -0.2	28	0 -0.2
LMK 8S	4	8		15		17		32	
LMK 8	4	8		15		24		32	
LMK 10	4	10		19		29		39	
LMK 12	4	12	0 -0.013	21	0 -0.016	30	0 -0.3	42	0 -0.3
LMK 13	4	13		23		32		43	
LMK 16	5	16		28		37		48	
LMK 20	5	20	0 -0.010	32	0 -0.019	42	0 -0.3	54	0 -0.3
LMK 25	6	25		40		59		62	
LMK 30	6	30		45		64		74	
LMK 35	6	35	0 -0.012	52	0 -0.022	70	0 -0.3	82	0 -0.3
LMK 40	6	40		60		80		96	
LMK 50	6	50		80		100		116	
LMK 60	6	60		90		110		134	

Note) Since this model contains a synthetic resin retainer, do not use it at temperature exceeding 80°C.
If requiring a type equipped with a seal, indicate it when placing an order.

(Example) LMK13 UU

_____ Seal attached on both ends of the nut

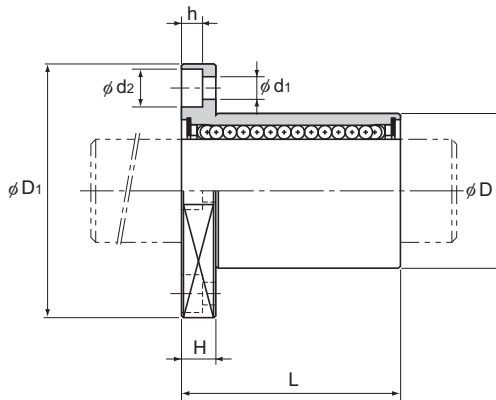

Unit: mm

	K	H	PCD	Mounting hole $d_1 \times d_2 \times h$	Flange perpendicularity μm	Eccentricity (max) μm	Radial clearance tolerance μm	Basic load rating		Mass g
								C N	C_0 N	
	22	5	20	$3.4 \times 6.5 \times 3.3$	12	12	-5	206	265	17
	25	5	24	$3.4 \times 6.5 \times 3.3$	12	12	-5	176	225	25
	25	5	24	$3.4 \times 6.5 \times 3.3$	12	12	-5	265	402	26
	30	6	29	$4.5 \times 8 \times 4.4$	12	12	-5	373	549	45
	32	6	32	$4.5 \times 8 \times 4.4$	12	12	-5	412	598	50
	34	6	33	$4.5 \times 8 \times 4.4$	12	12	-7	510	775	67
	37	6	38	$4.5 \times 8 \times 4.4$	12	12	-7	775	1180	105
	42	8	43	$5.5 \times 9.2 \times 5.4$	15	15	-9	863	1370	130
	50	8	51	$5.5 \times 9.2 \times 5.4$	15	15	-9	980	1570	270
	58	10	60	$6.6 \times 11 \times 6.5$	15	15	-9	1570	2750	344
	64	10	67	$6.6 \times 11 \times 6.5$	20	20	-13	1670	3140	487
	75	13	78	$9 \times 14 \times 8.6$	20	20	-13	2160	4020	790
	92	13	98	$9 \times 14 \times 8.6$	20	20	-13	3820	7940	1705
	106	18	112	$11 \times 17.5 \times 10.8$	25	25	-13	4710	10000	2278

Note) If an oil hole is required, this can be indicated by appending "OH" to the end of the model number.
For further information, contact THK.

Model LMK-M (Stainless Steel Type)

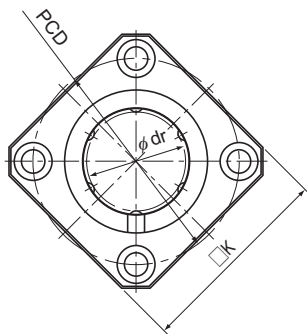

Model LMK-M

Model No.	Ball rows	Main dimensions							
		Inscribed bore diameter		Outer diameter		Length		Flange diameter	
		dr	Tolerance	D	Tolerance	L	Tolerance	D _i	Tolerance
LMK 6M	4	6	0 -0.009	12	0 -0.011	19	0 -0.2	28	0 -0.2
LMK 8SM	4	8		15		17		32	
LMK 8M	4	8		15	24	32			
LMK 10M	4	10		19	29	39			
LMK 12M	4	12	21	0 -0.013	30	42			
LMK 13M	4	13	23	32	43				
LMK 16M	5	16	28	37	48				
LMK 20M	5	20	32	0 -0.016	42	54			
LMK 25M	6	25	40	59	0 -0.3	62			
LMK 30M	6	30	45	64	74				

Note) Since this model contains a synthetic resin retainer, do not use it at temperature exceeding 80°C.
If requiring a type equipped with a seal, indicate it when placing an order.

(Example) LMK25M UU

└── Seal attached on both ends of the nut

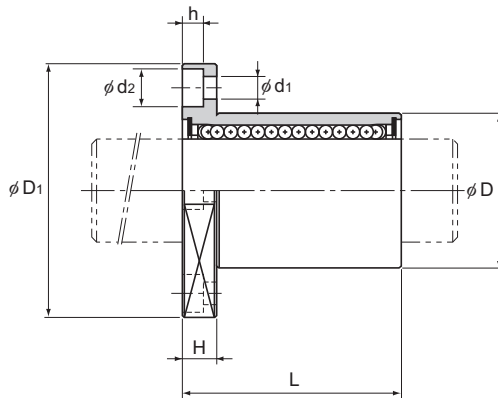

Unit: mm

	K	H	PCD	Mounting hole $d_1 \times d_2 \times h$	Flange perpendicularity	Eccentricity (max)	Radial clearance tolerance	Basic load rating		Mass g
					μm	μm	μm	C N	C_0 N	
	22	5	20	$3.4 \times 6.5 \times 3.3$	12	12	-5	206	265	17
	25	5	24	$3.4 \times 6.5 \times 3.3$	12	12	-5	176	225	25
	25	5	24	$3.4 \times 6.5 \times 3.3$	12	12	-5	265	402	26
	30	6	29	$4.5 \times 8 \times 4.4$	12	12	-5	373	549	45
	32	6	32	$4.5 \times 8 \times 4.4$	12	12	-5	412	598	50
	34	6	33	$4.5 \times 8 \times 4.4$	12	12	-7	510	775	67
	37	6	38	$4.5 \times 8 \times 4.4$	12	12	-7	775	1180	105
	42	8	43	$5.5 \times 9.2 \times 5.4$	15	15	-9	863	1370	130
	50	8	51	$5.5 \times 9.2 \times 5.4$	15	15	-9	980	1570	270
	58	10	60	$6.6 \times 11 \times 6.5$	15	15	-9	1570	2750	344

Note) Since the nut and the balls use stainless steel, these models are highly resistant to corrosion and environment.
If an oil hole is required, this can be indicated by appending "OH" to the end of the model number.
For further information, contact THK.

Model LMK-L

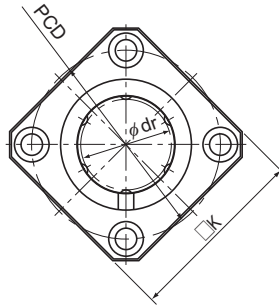

Model LMK-L

Model No.	Ball rows	Main dimensions							
		Inscribed bore diameter		Outer diameter		Length		Flange diameter	
		dr	Tolerance	D	Tolerance	L	Tolerance	D ₁	Tolerance
LMK 6L	4	6	0 -0.010	12	0	35	0 -0.3	28	0 -0.2
LMK 8L	4	8		15	-0.013	45		32	
LMK 10L	4	10		19	0 -0.016	55		39	
LMK 12L	4	12		21		57		42	
LMK 13L	4	13	23	0 -0.012	61	0 -0.4	43	0 -0.2	
LMK 16L	5	16	28		70		48		
LMK 20L	5	20	32	0	80	0 -0.4	54	0 -0.2	
LMK 25L	6	25	40	-0.019	112		62		
LMK 30L	6	30	45	0 -0.015	123	0 -0.4	74	0 -0.2	
LMK 35L	6	35	52		135		82		
LMK 40L	6	40	60	0	154	0 -0.4	96	0 -0.3	
LMK 50L	6	50	80	-0.022	192		116		
LMK 60L	6	60	0	90	0	211	134	0 -0.3	

Note) Since this model contains a synthetic resin retainer, do not use it at temperature exceeding 80°C.
If requiring a type equipped with a seal, indicate it when placing an order.

(Example) LMK50L UU

└─── Seal attached on both ends of the nut

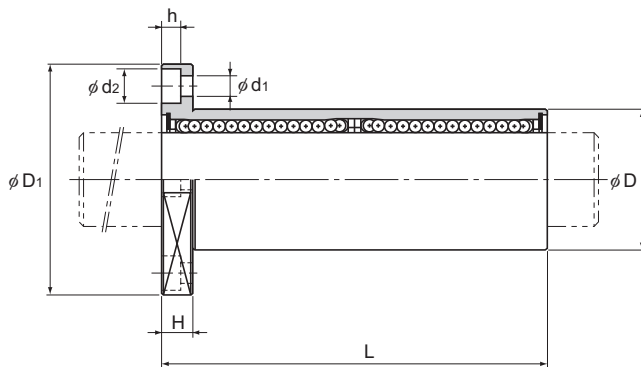

Unit: mm

	K	H	PCD	Mounting hole $d_1 \times d_2 \times h$	Flange perpendicularity	Eccentricity (max)	Radial clearance tolerance	Basic load rating		Mass g
					μm	μm	μm	C N	C_0 N	
	22	5	20	$3.4 \times 6.5 \times 3.3$	15	15	-5	324	529	24
	25	5	24	$3.4 \times 6.5 \times 3.3$	15	15	-5	431	784	39
	30	6	29	$4.5 \times 8 \times 4.4$	15	15	-5	588	1100	68
	32	6	32	$4.5 \times 8 \times 4.4$	15	15	-5	657	1200	76
	34	6	33	$4.5 \times 8 \times 4.4$	15	15	-7	814	1570	100
	37	6	38	$4.5 \times 8 \times 4.4$	15	15	-7	1230	2350	176
	42	8	43	$5.5 \times 9.2 \times 5.4$	20	20	-9	1400	2750	210
	50	8	51	$5.5 \times 9.2 \times 5.4$	20	20	-9	1560	3140	466
	58	10	60	$6.6 \times 11 \times 6.5$	20	20	-9	2490	5490	569
	64	10	67	$6.6 \times 11 \times 6.5$	25	25	-13	2650	6270	825
	75	13	78	$9 \times 14 \times 8.6$	25	25	-13	3430	8040	1321
	92	13	98	$9 \times 14 \times 8.6$	25	25	-13	6080	15900	2952
	106	18	112	$11 \times 17.5 \times 10.8$	25	25	-13	7650	20000	3883

Note) If an oil hole is required, this can be indicated by appending "OH" to the end of the model number.
For further information, contact THK.

Model LMK-ML (Stainless Steel Type)

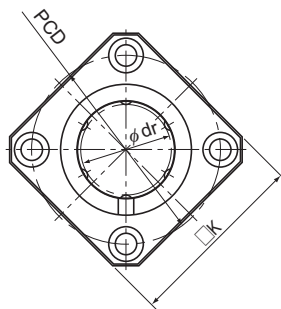

Model LMK-ML

Model No. Standard type	Ball rows	Main dimensions							
		Inscribed bore diameter		Outer diameter		Length		Flange diameter	
		dr	Tolerance	D	Tolerance	L	Tolerance	D ₁	Tolerance
LMK 6ML	4	6	0 -0.010	12	0	35	0 -0.3	28	0 -0.2
LMK 8ML	4	8		15	-0.013	45		32	
LMK 10ML	4	10		19	0 -0.016	55		39	
LMK 12ML	4	12		21		57		42	
LMK 13ML	4	13		23		61		43	
LMK 16ML	5	16	28	0 -0.019	70	48			
LMK 20ML	5	20	32		80	54			
LMK 25ML	6	25	40		112	62			
LMK 30ML	6	30	45	123	-0.4	74			

Note) Since this model contains a synthetic resin retainer, do not use it at temperature exceeding 80°C.
If requiring a type equipped with a seal, indicate it when placing an order.

(Example) LMK8ML UU

└── Seal attached on both ends of the nut

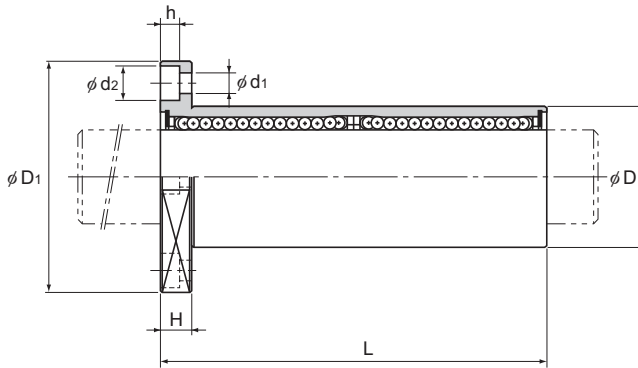

Unit: mm

	K	H	PCD	Mounting hole $d_1 \times d_2 \times h$	Flange perpendicularity	Eccentricity (max)	Radial clearance tolerance	Basic load rating		Mass g
					μm	μm	μm	C N	C_0 N	
	22	5	20	$3.4 \times 6.5 \times 3.3$	15	15	-5	324	529	24
	25	5	24	$3.4 \times 6.5 \times 3.3$	15	15	-5	431	784	39
	30	6	29	$4.5 \times 8 \times 4.4$	15	15	-5	588	1100	68
	32	6	32	$4.5 \times 8 \times 4.4$	15	15	-5	657	1200	76
	34	6	33	$4.5 \times 8 \times 4.4$	15	15	-7	814	1570	100
	37	6	38	$4.5 \times 8 \times 4.4$	15	15	-7	1230	2350	176
	42	8	43	$5.5 \times 9.2 \times 5.4$	20	20	-9	1400	2750	210
	50	8	51	$5.5 \times 9.2 \times 5.4$	20	20	-9	1560	3140	466
	58	10	60	$6.6 \times 11 \times 6.5$	20	20	-9	2490	5490	569

Note) Since the nut and the balls use stainless steel, these models are highly resistant to corrosion and environment.
If an oil hole is required, this can be indicated by appending "OH" to the end of the model number.
For further information, contact THK.

Model LMJK

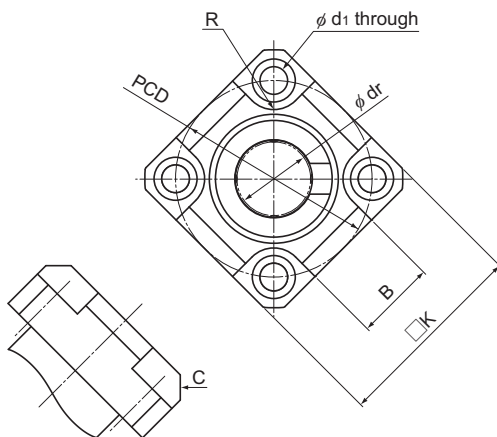

Model LMJK

Model No.	Ball rows	Main dimensions							
		Inscribed bore diameter		Outer diameter		Length		Flange diameter	
		dr	Tolerance	D	Tolerance	L	Tolerance	D ₁	Tolerance
LMJK 8	4	8	0 -0.009	15	0 -0.011	24	0 -0.2	32	0 -0.2
LMJK 10	4	10		19	0	29		39	
LMJK 12	4	12		21	0 -0.013	30		42	
LMJK 16	5	16		28	0	37		48	
LMJK 20	5	20	32	0	42	54			
LMJK 25	6	25	40	0 -0.016	59	0 -0.3	62		

Note) Includes synthetic resin; do not use in temperatures exceeding 80°C.
If seals must be attached, please specify when placing an order.

(Example) LMJK8 UU

└── Seal attached on both ends of the nut

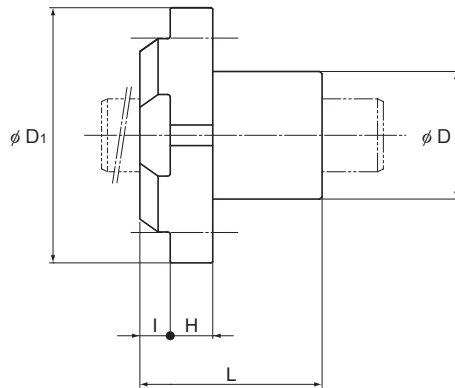

Unit: mm

	K	B	R	H	I	C	PCD	Mounting hole d_i	Flange perpendicularity	Eccentricity (max)	Radial clearance tolerance	Basic load rating		Mass g
									μm	μm	μm	C N	C_0 N	
	25	10	R4	6	4	C3	24	3.4	12	12	-5	265	402	20
	30	12	R5	7	5		29	4.5				373	549	35
	32	13					412					598	38	
	37	18					775					1180	88	
	42	21	R6	10	6		43	5.5			15	15	-7	863
	50	26				51	-9		980	1570			234	

Model LMJK-L

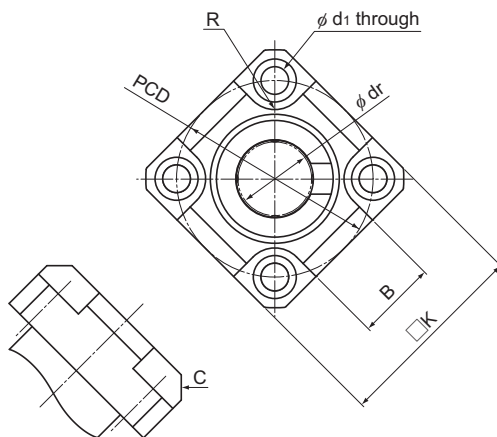

Model LMJK-L

Model No.	Ball rows	Main dimensions							
		Inscribed bore diameter		Outer diameter		Length		Flange diameter	
		dr	Tolerance	D	Tolerance	L	Tolerance	D ₁	Tolerance
LMJK 8L	4	8	0 -0.010	15	0 -0.013	45	0 -0.3	32	0 -0.2
LMJK 10L	4	10		19	0	55		39	
LMJK 12L	4	12		21	0 -0.016	57		42	
LMJK 16L	5	16		28	0	70		48	
LMJK 20L	5	20	32	0 -0.019	80	54			
LMJK 25L	6	25	40	0 -0.019	112	0 -0.4	62		

Note) Includes synthetic resin; do not use in temperatures exceeding 80°C.

If seals must be attached, please specify when placing an order.

(Example) LMJK8L UU

Seal attached on both ends of the nut

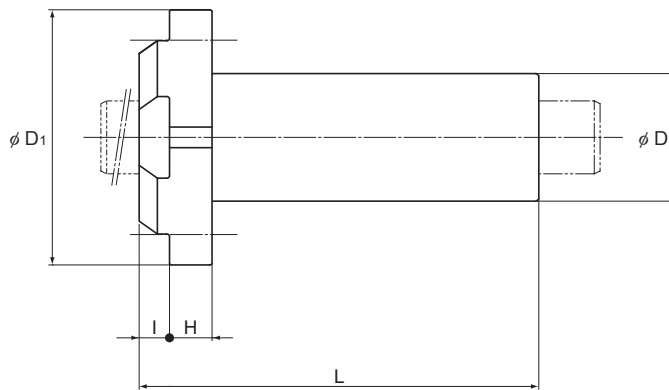

Unit: mm

	K	B	R	H	I	C	PCD	Mounting hole d_i	Flange perpendicularity	Eccentricity (max)	Radial clearance tolerance	Basic load rating		Mass g
									μm	μm	μm	C N	C_o N	
	25	10	R4	6	4	C3	24	3.4	15	15	-5	431	784	32
	30	12	R5	7	5		29	4.5				588	1100	58
	32	13					657					1200	63	
	37	18					1230					2350	158	
	42	21	R6	10	6		43	5.5				20	20	-7
	50	26				51	1560		3140	421				

Model LMH

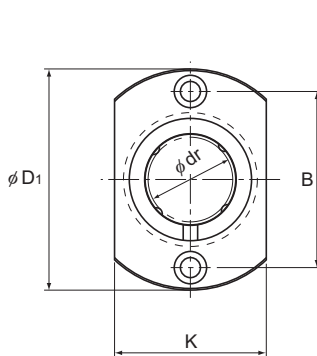

Models LMH6 to 13

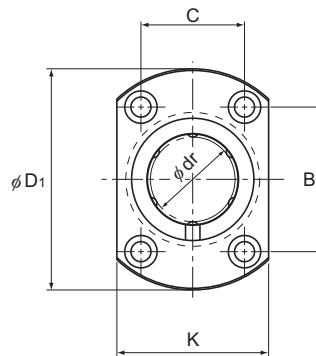

Models LMH16 to 30

Model No.	Ball rows	Main dimensions							
		Inscribed bore diameter		Outer diameter		Length		Flange diameter	
Standard type		dr	Tolerance	D	Tolerance	L	Tolerance	D ₁	Tolerance
LMH 6	4	6	0 -0.009	12	0	19	0 -0.2	28	0 -0.2
LMH 8S	4	8		15		-0.011		17	
LMH 8	4	8		15	24			32	
LMH 10	4	10		19	29			39	
LMH 12	4	12		21	0 -0.013	30		42	
LMH 13	4	13	23	32		43			
LMH 16	5	16	28	37	48				
LMH 20	5	20	32	0 -0.016	42	54			
LMH 25	6	25	40		59	62			
LMH 30	6	30	45		64	74			

Note) Since this model contains a synthetic resin retainer, do not use it at temperature exceeding 80°C.
If requiring a type equipped with a seal, indicate it when placing an order.

(Example) LMH16 UU

└────────── Seal attached on both ends of the nut

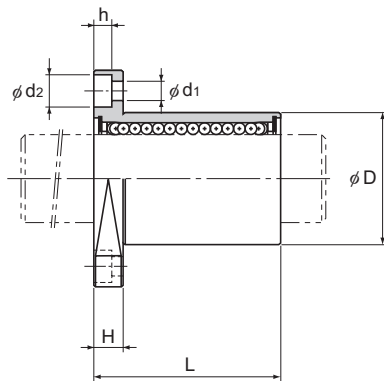

Unit: mm

	K	H	B	C	Mounting hole d ₁ × d ₂ × h	Flange perpendicularity	Eccentricity (max)	Radial clearance tolerance	Basic load rating		Mass g
						μm	μm	μm	C N	C ₀ N	
	18	5	20	—	3.4 × 6.5 × 3.3	12	12	-5	206	265	20
	21	5	24	—	3.4 × 6.5 × 3.3	12	12	-5	176	225	24
	21	5	24	—	3.4 × 6.5 × 3.3	12	12	-5	265	402	28
	25	6	29	—	4.5 × 8 × 4.4	12	12	-5	373	549	50
	27	6	32	—	4.5 × 8 × 4.4	12	12	-5	412	598	56
	29	6	33	—	4.5 × 8 × 4.4	12	12	-7	510	775	69
	34	6	31	22	4.5 × 8 × 4.4	12	12	-7	775	1180	111
	38	8	36	24	5.5 × 9.2 × 5.4	15	15	-9	863	1370	140
	46	8	40	32	5.5 × 9.2 × 5.4	15	15	-9	980	1570	279
	51	10	49	35	6.6 × 11 × 6.5	15	15	-9	1570	2750	351

Note) If an oil hole is required, this can be indicated by appending "OH" to the end of the model number.
For further information, contact THK.

Model LMH-M (Stainless Steel Type)

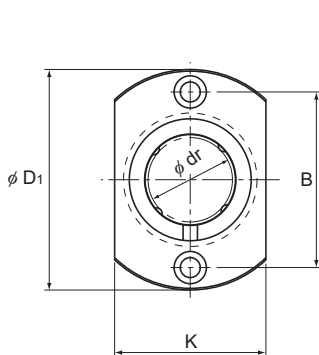

Models LMH 6M to 13M

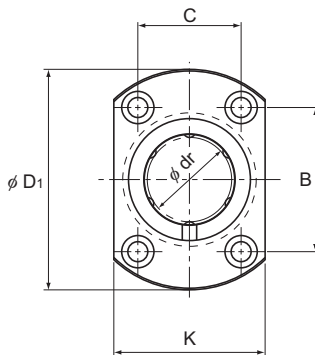

Models LMH 16M to 30M

Model No.	Ball rows	Main dimensions							
		Inscribed bore diameter		Outer diameter		Length		Flange diameter	
		dr	Tolerance	D	Tolerance	L	Tolerance	D ₁	Tolerance
LMH 6M	4	6	0 -0.009	12	0 -0.011	19	0 -0.2	28	0 -0.2
LMH 8SM	4	8		15		17		32	
LMH 8M	4	8		15		24		32	
LMH 10M	4	10		19	29	39			
LMH 12M	4	12		21	30	42			
LMH 13M	4	13	23	32	43				
LMH 16M	5	16	28	37	48				
LMH 20M	5	20	32	42	54				
LMH 25M	6	25	40	59	62				
LMH 30M	6	30	45	64	74				

Note) Since this model contains a synthetic resin retainer, do not use it in temperatures exceeding 80°C.
If an equipped seal is required, please specify when placing an order.

(Example) LMH16M UU

└─── Seal attached on both ends of the nut

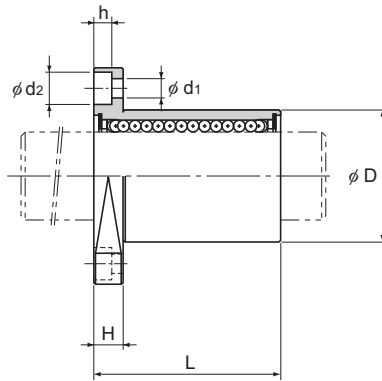

Unit: mm

	K	H	B	C	Mounting hole d ₁ × d ₂ × h	Flange perpendicularity μm	Eccentricity (max) μm	Radial clearance tolerance μm	Basic load rating		Mass g
									C N	C ₀ N	
	18	5	20	—	3.4 × 6.5 × 3.3	12	12	-5	206	265	20
	21	5	24	—	3.4 × 6.5 × 3.3	12	12	-5	176	225	24
	21	5	24	—	3.4 × 6.5 × 3.3	12	12	-5	265	402	28
	25	6	29	—	4.5 × 8 × 4.4	12	12	-5	373	549	50
	27	6	32	—	4.5 × 8 × 4.4	12	12	-5	412	598	56
	29	6	33	—	4.5 × 8 × 4.4	12	12	-7	510	775	69
	34	6	31	22	4.5 × 8 × 4.4	12	12	-7	775	1180	111
	38	8	36	24	5.5 × 9.2 × 5.4	15	15	-9	863	1370	140
	46	8	40	32	5.5 × 9.2 × 5.4	15	15	-9	980	1570	279
	51	10	49	35	6.6 × 11 × 6.5	15	15	-9	1570	2750	351

Note) Since the nut and the balls use stainless steel, these models are highly resistant to corrosion and environment.
If oil holes are required, please specify by adding OH to the end of the model number.
For further information, contact THK.

Model LMH-L

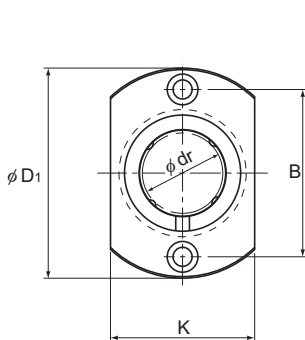

Models LMH6L to 13L

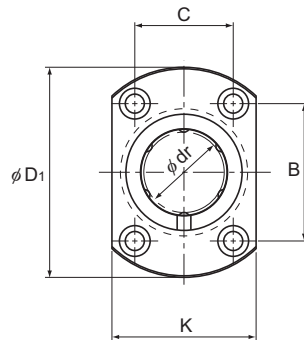

Models LMH16L to 30L

Model No.	Ball rows	Main dimensions							
		Inscribed bore diameter		Outer diameter		Length		Flange diameter	
Standard type		dr	Tolerance	D	Tolerance	L	Tolerance	D_1	Tolerance
LMH 6L	4	6	0 -0.010	12	0	35	0 -0.3	28	0 -0.2
LMH 8L	4	8		15	-0.013	45		32	
LMH 10L	4	10		19	55	39			
LMH 12L	4	12		21	0	57		42	
LMH 13L	4	13		23	-0.016	61		43	
LMH 16L	5	16	28	70	48				
LMH 20L	5	20	32	0	80	54			
LMH 25L	6	25	40	-0.019	112	0	62		
LMH 30L	6	30	45	123	-0.4	74			

Note) Since this model contains a synthetic resin retainer, do not use it at temperature exceeding 80°C.
If requiring a type equipped with a seal, indicate it when placing an order.

(Example) LMH20L UU

Seal attached on both ends of the nut

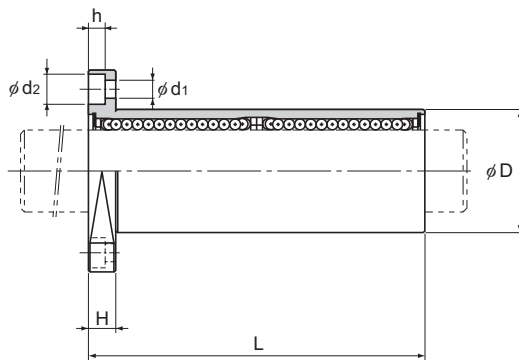

Unit: mm

	K	H	B	C	Mounting hole $d_1 \times d_2 \times h$	Flange perpendicularity μm	Eccentricity (max) μm	Radial clearance tolerance μm	Basic load rating		Mass g
									C N	C_0 N	
	18	5	20	—	$3.4 \times 6.5 \times 3.3$	15	15	-5	324	529	27
	21	5	24	—	$3.4 \times 6.5 \times 3.3$	15	15	-5	431	784	41
	25	6	29	—	$4.5 \times 8 \times 4.4$	15	15	-5	588	1100	72
	27	6	32	—	$4.5 \times 8 \times 4.4$	15	15	-5	657	1200	81
	29	6	33	—	$4.5 \times 8 \times 4.4$	15	15	-7	814	1570	105
	34	6	31	22	$4.5 \times 8 \times 4.4$	15	15	-7	1230	2350	182
	38	8	36	24	$5.5 \times 9.2 \times 5.4$	20	20	-9	1400	2750	217
	46	8	40	32	$5.5 \times 9.2 \times 5.4$	20	20	-9	1560	3140	477
	51	10	49	35	$6.6 \times 11 \times 6.5$	20	20	-9	2490	5490	575

Note) If an oil hole is required, this can be indicated by appending "OH" to the end of the model number.
For further information, contact THK.

Model LMH-ML (Stainless Steel Type)

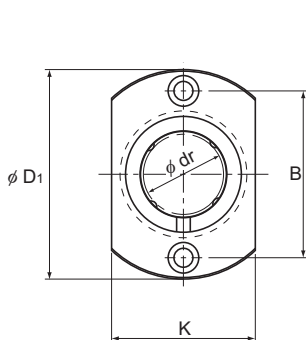

Models LMH 6ML to 13ML

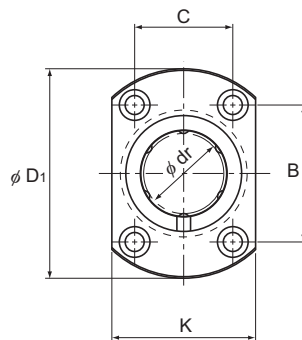

Models LMH 16ML to 30ML

Model No.	Ball rows	Main dimensions							
		Inscribed bore diameter		Outer diameter		Length		Flange diameter	
		dr	Tolerance	D	Tolerance	L	Tolerance	D_1	Tolerance
LMH 6ML	4	6	0 -0.010	12	0	35	0 -0.3	28	0 -0.2
LMH 8ML	4	8		15	-0.013	45		32	
LMH 10ML	4	10		19	0 -0.016	55		39	
LMH 12ML	4	12		21		57		42	
LMH 13ML	4	13		23		61		43	
LMH 16ML	5	16	28	70	48				
LMH 20ML	5	20	32	80	54				
LMH 25ML	6	25	40	0 -0.019	112	0	62		
LMH 30ML	6	30	45		123	-0.4	74		

Note) Since this model contains a synthetic resin retainer, do not use it at temperature exceeding 80°C.
If an equipped seal is required, please specify when placing an order.

(Example) LMH20ML UU

Seal attached on both ends of the nut

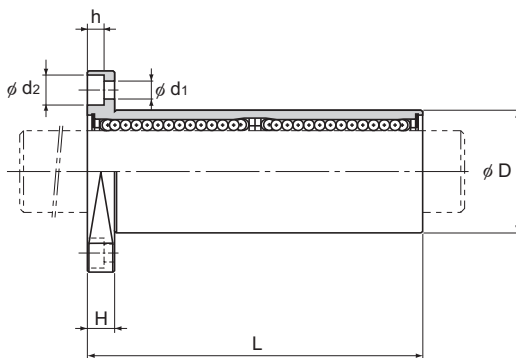

Unit: mm

	K	H	B	C	Mounting hole d ₁ × d ₂ × h	Flange perpendicularity	Eccentricity (max)	Radial clearance tolerance	Basic load rating		Mass g
						μm	μm	μm	C N	C ₀ N	
	18	5	20	—	3.4 × 6.5 × 3.3	15	15	-5	324	529	27
	21	5	24	—	3.4 × 6.5 × 3.3	15	15	-5	431	784	41
	25	6	29	—	4.5 × 8 × 4.4	15	15	-5	588	1100	72
	27	6	32	—	4.5 × 8 × 4.4	15	15	-5	657	1200	81
	29	6	33	—	4.5 × 8 × 4.4	15	15	-7	814	1570	105
	34	6	31	22	4.5 × 8 × 4.4	15	15	-7	1230	2350	182
	38	8	36	24	5.5 × 9.2 × 5.4	20	20	-9	1400	2750	217
	46	8	40	32	5.5 × 9.2 × 5.4	20	20	-9	1560	3140	477
	51	10	49	35	6.6 × 11 × 6.5	20	20	-9	2490	5490	575

Note) Since the nut and the balls use stainless steel, these models are highly resistant to corrosion and environment.
If oil holes are required, please specify by adding OH to the end of the model number.
For further information, contact THK.

Model LMIF

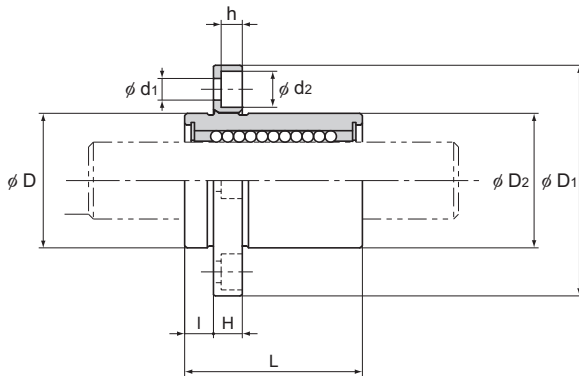

Model LMIF

Model No.	Ball rows	Main dimensions							
		Inscribed bore diameter		Outer diameter		Overall length		Flange diameter	
		dr	Tolerance	D	Tolerance	L	Tolerance	D ₁	Tolerance
LMIF 6	4	6	0 -0.009	12	0	19	±0.3	28	0 -0.2
LMIF 8		8		15	-0.011	24		32	
LMIF 10		10		19	29	39			
LMIF 12		12		21	0	30		42	
LMIF 13		13		23	-0.013	32		43	
LMIF 16	5	16	0 -0.010	28	0 -0.016	37	±0.3	48	0 -0.2
LMIF 20		20		32		42		54	
LMIF 25		25		40		59		62	

Note) Since this model contains a synthetic resin retainer, do not use it at temperature exceeding 80°C.
If requiring a type equipped with a seal, indicate it when placing an order.

(Example) LMIF16 UU

└ Seal attached on both ends of the nut

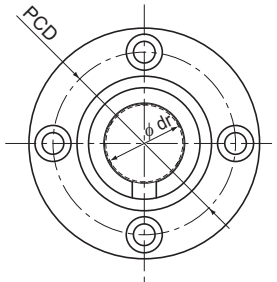

Unit: mm

	Length		D_2	H	PCD	Mounting hole $d_1 \times d_2 \times h$	Flange	Eccentricity (max) μm	Radial clearance tolerance μm	Basic Load Rating		Mass g
	l	Tolerance					perpendicularity μm			C	C_0	
5		± 0.2	12	5	20	$3.4 \times 6 \times 3.3$	12	12	-5	206	265	24
			15		24		12		-5	265	402	34
6		± 0.2	19	6	29	$4.5 \times 7.5 \times 4.4$	12	12	-5	373	549	61
			21		32		12		-5	412	598	69
			23		33		12		-7	510	775	81
			28		38		12		-7	775	1180	125
8		± 0.2	32	8	43	$5.5 \times 9 \times 5.4$	15	15	-9	863	1370	166
			40		51		15		-9	980	1570	305

Note) If an oil hole is required, this can be indicated by appending "OH" to the end of the model number.
For further information, contact THK.

Model LMIF-L

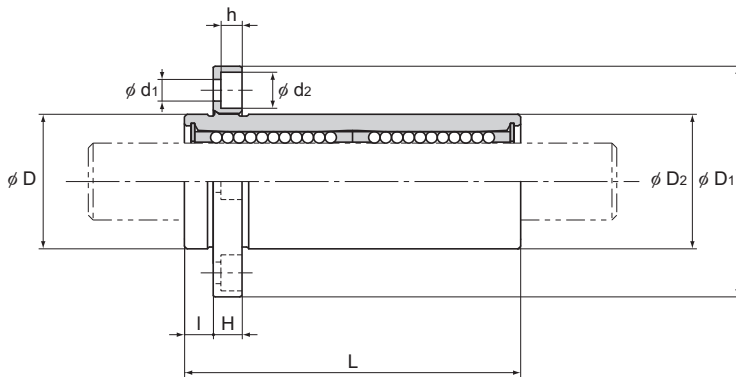

Model LMIF-L

Model No.	Ball rows	Main dimensions							
		Inscribed bore diameter		Outer diameter		Overall length		Flange diameter	
		dr	Tolerance	D	Tolerance	L	Tolerance	D ₁	Tolerance
LMIF 6L	4	6	0 -0.010	12	0	35	±0.3	28	0 -0.2
LMIF 8L		8		15	-0.013	45		32	
LMIF 10L		10		19	55	39			
LMIF 12L		12		21	0	57		42	
LMIF 13L		13		23	-0.016	61		43	
LMIF 16L		16		28	70	48			
LMIF 20L	5	20	0	32	0	80	54		
LMIF 25L	6	25	-0.012	40	-0.019	112	62		

Note) Since this model contains a synthetic resin retainer, do not use it at temperature exceeding 80°C.
If requiring a type equipped with a seal, indicate it when placing an order.

(Example) LMIF16L UU

└── Seal attached on both ends of the nut

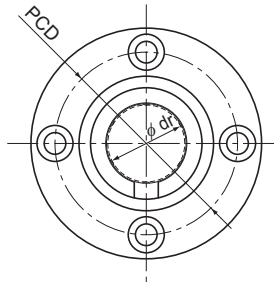

Unit: mm

	Length		D_2	H	PCD	Mounting hole $d_1 \times d_2 \times h$	Flange	Eccentricity (max) μm	Radial clearance tolerance μm	Basic Load Rating		Mass g
	l	Tolerance					perpendicularity μm			C	C_0	
5		± 0.2	12	5	20	$3.4 \times 6 \times 3.3$	12	12	-5	324	529	30
			15		24		12		-5	431	784	46
6		± 0.2	19	6	29	$4.5 \times 7.5 \times 4.4$	12	12	-5	588	1100	83
			21		32		12		-5	657	1200	95
			23		33		12		-7	814	1570	117
			28		38		12		-7	1230	2350	196
8		± 0.2	32	8	43	$5.5 \times 9 \times 5.4$	15	15	-9	1400	2750	244
			40		51		15		-9	1560	3140	498

Note) If an oil hole is required, this can be indicated by appending "OH" to the end of the model number.
For further information, contact THK.

Model LMCF-L

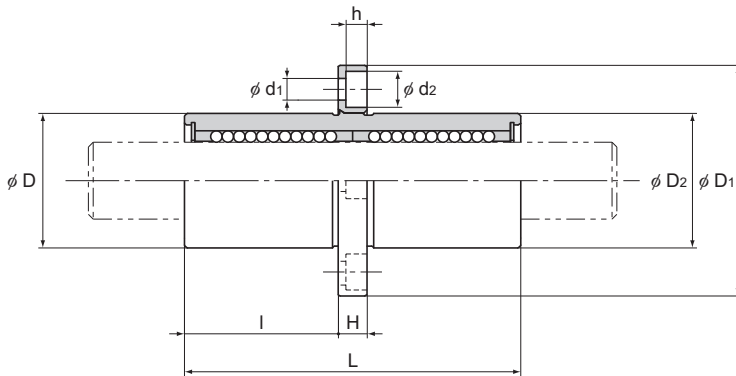

Model LMCF-L

Model No.	Ball rows	Main dimensions							
		Inscribed bore diameter		Outer diameter		Overall length		Flange diameter	
		dr	Tolerance	D	Tolerance	L	Tolerance	D ₁	Tolerance
LMCF 6L	4	6	0 -0.010	12	0	35	±0.3	28	0 -0.2
LMCF 8L		8		15	-0.013	45		32	
LMCF 10L		10		19	55	39			
LMCF 12L		12		21	0	57		42	
LMCF 13L		13		23	-0.016	61		43	
LMCF 16L	5	16	0	28	0	70	±0.3	48	0 -0.2
LMCF 20L		20		32	80	54			
LMCF 25L		25		-0.012	40	-0.019		112	

Note) Since this model contains a synthetic resin retainer, do not use it at temperature exceeding 80°C.
If requiring a type equipped with a seal, indicate it when placing an order.

(Example) LMCF16L UU

└── Seal attached on both ends of the nut

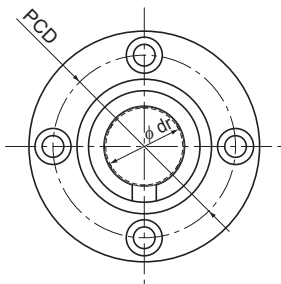

Unit: mm

						Flange perpendicularity	Eccentricity (max)	Radial clearance tolerance	Basic Load Rating		Mass
Length		D ₂	H	PCD	Mounting hole d ₁ × d ₂ × h				μm	μm	
l	Tolerance										
15	±0.2	12	5	20	3.4 × 6 × 3.3	12	12	-5	324	529	30
20		15		24		12		-5	431	784	46
24.5		19		29		12		-5	588	1100	83
25.5		21	6	32	4.5 × 7.5 × 4.4	12		-5	657	1200	95
27.5		23		33		12		-7	814	1570	117
32		28		38		12		-7	1230	2350	196
36		32		8		43	5.5 × 9 × 5.4	15	-9	1400	2750
52		40	51		15	-9		1560	3140	498	

Note) If an oil hole is required, this can be indicated by appending "OH" to the end of the model number.
For further information, contact THK.

Model LMIK

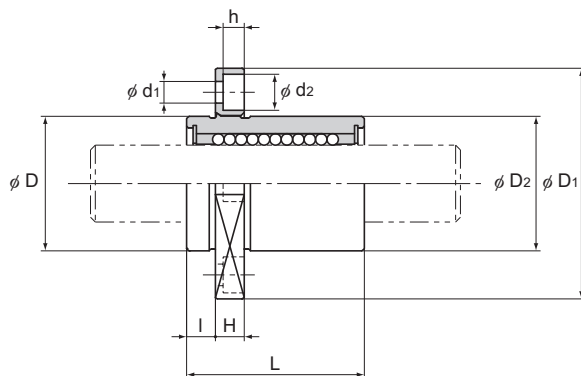

Model LMIK

Model No.	Ball rows	Main dimensions							
		Inscribed bore diameter		Outer diameter		Overall length		Flange diameter	
		dr	Tolerance	D	Tolerance	L	Tolerance	D ₁	Tolerance
LMIK 6	4	6	0 -0.009	12	0	19	±0.3	28	0 -0.2
LMIK 8		8		15	-0.011	24		32	
LMIK 10		10		19	29	39			
LMIK 12		12		21	0	30		42	
LMIK 13		13		23	-0.013	32		43	
LMIK 16	5	16	0 -0.010	28	0 -0.016	37	±0.3	48	0 -0.2
LMIK 20		20		32		42		54	
LMIK 25		25		40		59		62	

Note) Since this model contains a synthetic resin retainer, do not use it at temperature exceeding 80°C.
If requiring a type equipped with a seal, indicate it when placing an order.

(Example) LMIK16 UU

└ Seal attached on both ends of the nut

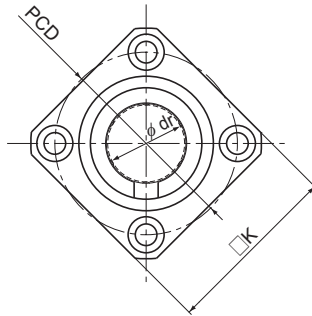

Unit: mm

								Flange perpendicularity	Eccentricity (max)	Radial clearance tolerance	Basic Load Rating		Mass
Length		D ₂	H	K	PCD	Mounting hole d ₁ ×d ₂ ×h	μm				μm	C	
I	Tolerance												
5		12	5	22	20	3.4×6×3.3	12	12	-5	206	265	18	
		15		25	24		12		-5	265	402	27	
6	±0.2	19	6	30	29	4.5×7.5×4.4	12	12	-5	373	549	46	
		21		32	32		12		-5	412	598	52	
		23		34	33		12		-7	510	775	65	
		28		37	38		12		-7	775	1180	104	
8		32	8	42	43	5.5×9×5.4	15	15	-9	863	1370	131	
		40		50	51		15		-9	980	1570	267	

Note) If an oil hole is required, this can be indicated by appending "OH" to the end of the model number.
For further information, contact THK.

Model LMIK-L

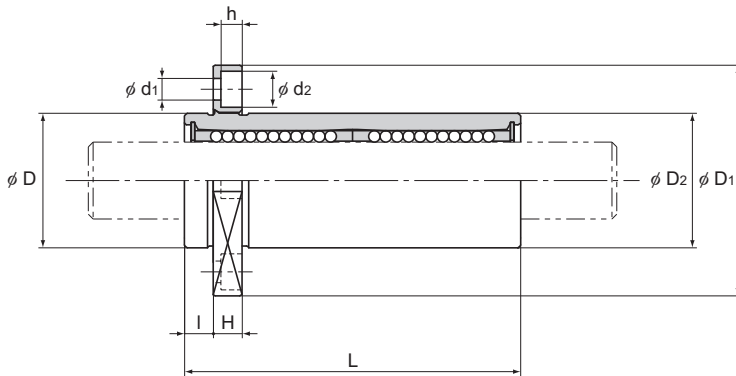

Model LMIK-L

Model No.	Ball rows	Main dimensions							
		Inscribed bore diameter		Outer diameter		Overall length		Flange diameter	
		dr	Tolerance	D	Tolerance	L	Tolerance	D ₁	Tolerance
LMIK 6L	4	6	0 -0.010	12	0	35	±0.3	28	0 -0.2
LMIK 8L		8		15	-0.013	45		32	
LMIK 10L		10		19	0 -0.016	55		39	
LMIK 12L		12		21		57		42	
LMIK 13L		13		23		61		43	
LMIK 16L	5	16	0 -0.012	28	0	70	±0.3	48	0 -0.2
LMIK 20L		20		32	80	54			
LMIK 25L		25		40	-0.019	112		62	

Note) Since this model contains a synthetic resin retainer, do not use it at temperature exceeding 80°C.
If requiring a type equipped with a seal, indicate it when placing an order.

(Example) LMIK16L UU

└ Seal attached on both ends of the nut

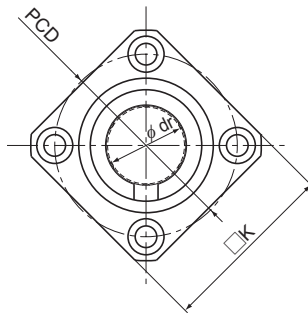

Unit: mm

	Length		D ₂	H	K	PCD	Mounting hole d ₁ × d ₂ × h	Flange	Eccentricity (max)	Radial clearance tolerance	Basic Load Rating		Mass	
	l	Tolerance						perpendicularity			μm	μm		C
5		±0.2	12	5	22	20	3.4 × 6 × 3.3	12	12	-5	324	529	25	
			15		25	24		12			-5	431	784	39
6		±0.2	19	6	30	29	4.5 × 7.5 × 4.4	12	12	-5	588	1100	69	
			21		32	32		12			-5	657	1200	78
			23		34	33		12			-7	814	1570	101
			28		37	38		12			-7	1230	2350	174
8		±0.2	32	8	42	43	5.5 × 9 × 5.4	15	15	-9	1400	2750	210	
			40		50	51		15			-9	1560	3140	461

Note) If an oil hole is required, this can be indicated by appending "OH" to the end of the model number.
For further information, contact THK.

Model LMCK-L

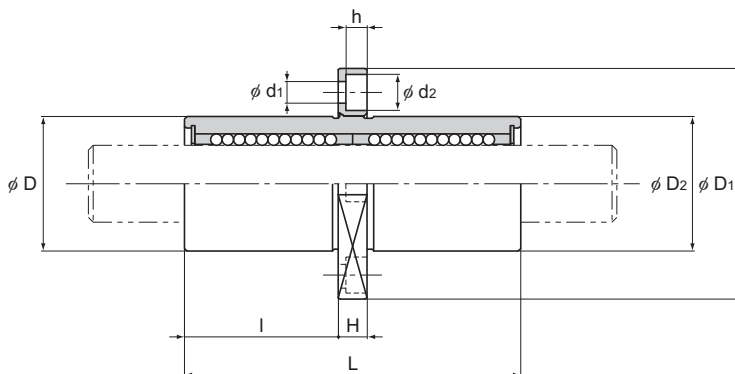

Model LMCK-L

Model No.	Ball rows	Main dimensions								
		Inscribed bore diameter		Outer diameter		Overall length		Flange diameter		
		dr	Tolerance	D	Tolerance	L	Tolerance	D ₁	Tolerance	
LMCK 6L	4	6	0 -0.010	12	0	35	±0.3	28	0 -0.2	
LMCK 8L		8		15	-0.013	45		32		
LMCK 10L		10		19	-0.016	55		39		
LMCK 12L		12		21		0		57		42
LMCK 13L		13		23		0		61		43
LMCK 16L	5	16	0	28	0	70	48	-0.2		
LMCK 20L		20		32	0	80	54			
LMCK 25L		25		-0.012	40	-0.019	112		62	

Note) Since this model contains a synthetic resin retainer, do not use it at temperature exceeding 80°C.
If requiring a type equipped with a seal, indicate it when placing an order.

(Example) LMCK16L UU

└── Seal attached on both ends of the nut

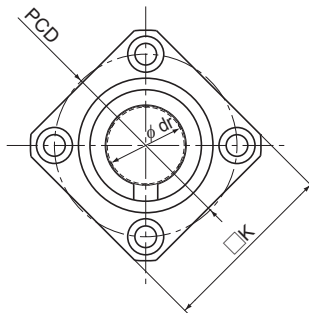

Unit: mm

Length		D ₂	H	K	PCD	Mounting hole d ₁ × d ₂ × h	Flange	Eccentricity (max)	Radial clearance tolerance	Basic Load Rating		Mass	
l	Tolerance						perpendicularity			μm	μm		C
15	±0.2	12	5	22	20	3.4 × 6 × 3.3	12	12	-5	324	529	25	
20		15		25	24		12		-5	431	784	39	
24.5		19	6	30	29	4.5 × 7.5 × 4.4	12		-5	588	1100	69	
25.5		21		32	32		12		-5	657	1200	78	
27.5		23		34	33		12		-7	814	1570	101	
32		28		37	38		12		-7	1230	2350	174	
36		32	8	42	43	5.5 × 9 × 5.4	15		15	-9	1400	2750	210
52		40		50	51		15			-9	1560	3140	461

Note) If an oil hole is required, this can be indicated by appending "OH" to the end of the model number.
For further information, contact THK.

Model LMIH

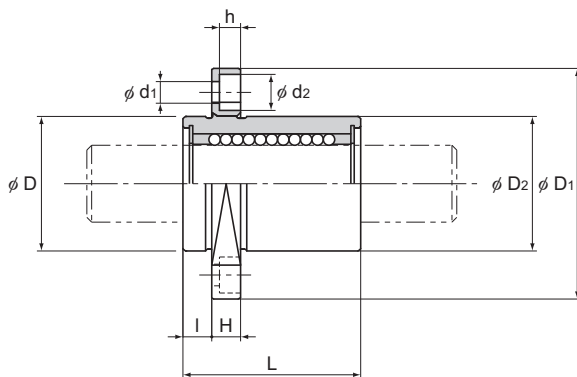

Model LMIH

Model No.	Ball rows	Main dimensions							
		Inscribed bore diameter		Outer diameter		Overall length		Flange diameter	
		dr	Tolerance	D	Tolerance	L	Tolerance	D ₁	Tolerance
LMIH 6	4	6	0 -0.009	12	0	19	±0.3	28	0 -0.2
LMIH 8		8		15	-0.011	24		32	
LMIH 10		10		19	29	39			
LMIH 12		12		21	0	30		42	
LMIH 13		13		23	-0.013	32		43	
LMIH 16	5	16	0 -0.010	28	0 -0.016	37	±0.3	48	0 -0.2
LMIH 20		20		32		42		54	
LMIH 25		25		40		59		62	

Note) Since this model contains a synthetic resin retainer, do not use it at temperature exceeding 80°C.
If requiring a type equipped with a seal, indicate it when placing an order.

(Example) LMIH16 UU

└ Seal attached on both ends of the nut

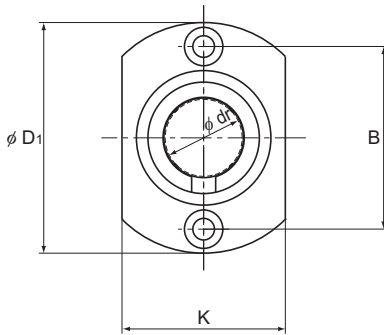

Models LMIH 6 to 13

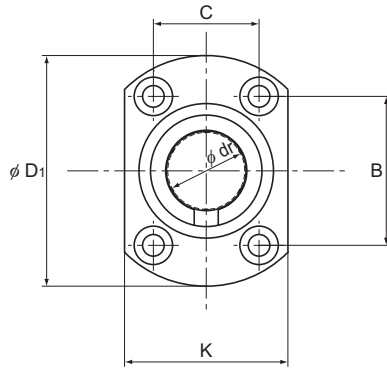

Models LMIH 16 to 25

Unit: mm

	Length		D ₂	H	K	B	C	Mounting hole d ₁ × d ₂ × h	Flange perpendicularity μm	Eccentricity (max) μm	Radial clearance tolerance μm	Basic Load Rating		Mass g	
	I	Tolerance										C	C ₀		
5		±0.2	12	5	18	20	—	3.4 × 6 × 3.3	12	12	-5	206	265	20	
			15		21	24	—		12			-5	265	402	29
6		±0.2	19	6	25	29	—	4.5 × 7.5 × 4.4	12	12	-5	373	549	50	
			21		27	32	—		12			-5	412	598	57
			23		29	33	—		12			-7	510	775	70
			28		34	31	22		12			-7	775	1180	111
8		±0.2	32	8	38	36	24	5.5 × 9 × 5.4	15	15	-9	863	1370	140	
			40		46	40	32		15			-9	980	1570	276

Note) If an oil hole is required, this can be indicated by appending "OH" to the end of the model number.
For further information, contact THK.

Model LMIH-L

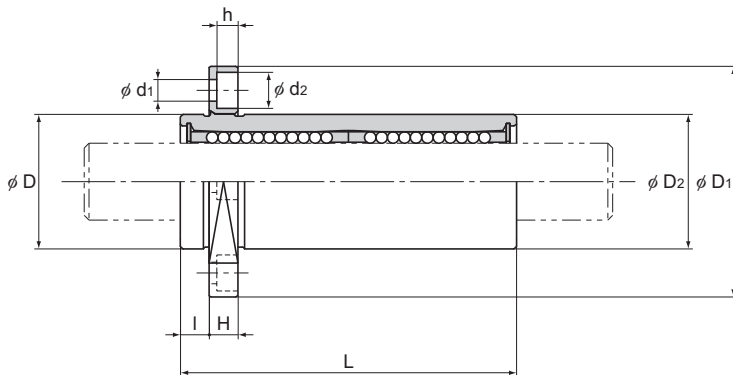

Model LMIH-L

Model No.	Ball rows	Main dimensions							
		Inscribed bore diameter		Outer diameter		Overall length		Flange diameter	
Standard Type		dr	Tolerance	D	Tolerance	L	Tolerance	D ₁	Tolerance
LMIH 6L	4	6	0 -0.010	12	0	35	±0.3	28	0 -0.2
LMIH 8L		8		15	-0.013	45		32	
LMIH 10L		10		19	0 -0.016	55		39	
LMIH 12L		12		21		57		42	
LMIH 13L		13		23		61		43	
LMIH 16L	5	16	0 -0.012	28	0	70	±0.3	48	0 -0.2
LMIH 20L		20		32	80	54			
LMIH 25L		25		40	-0.019	112		62	

Note) Since this model contains a synthetic resin retainer, do not use it at temperature exceeding 80°C.
If requiring a type equipped with a seal, indicate it when placing an order.

(Example) LMIH16L UU

└── Seal attached on both ends of the nut

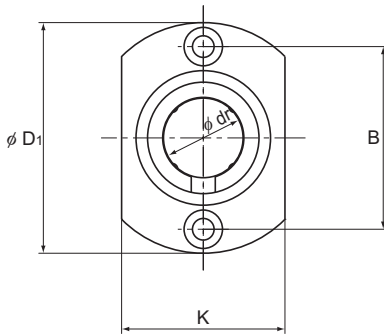

Models LMIH 6L to 13L

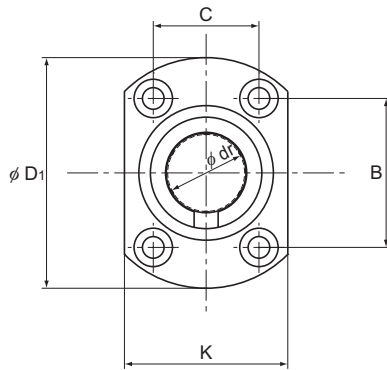

Models LMIH 16L to 25L

Unit: mm

	Length		D ₂	H	K	B	C	Mounting hole d ₁ × d ₂ × h	Flange perpendicularity μm	Eccentricity (max) μm	Radial clearance tolerance μm	Basic Load Rating		Mass g
	I	Tolerance										C	C ₀	
5		±0.2	12	5	18	20	—	3.4 × 6 × 3.3	12	12	-5	324	529	26
			15		21	24	—		12		-5	431	784	41
6		±0.2	19	6	25	29	—	4.5 × 7.5 × 4.4	12	12	-5	588	1100	73
			21		27	32	—		12		-5	657	1200	83
			23		29	33	—		12		-7	814	1570	106
			28		34	31	22		12		-7	1230	2350	180
8		±0.2	32	8	38	36	24	5.5 × 9 × 5.4	15	15	-9	1400	2750	219
			40		46	40	32		15		-9	1560	3140	470

Note) If an oil hole is required, this can be indicated by appending "OH" to the end of the model number.
For further information, contact THK.

Model LMCH-L

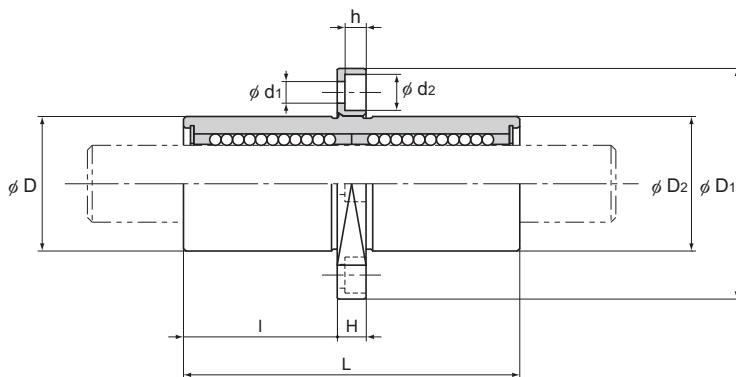

Model LMCH-L

Model No.	Ball rows	Main dimensions							
		Inscribed bore diameter		Outer diameter		Overall length		Flange diameter	
		dr	Tolerance	D	Tolerance	L	Tolerance	D ₁	Tolerance
LMCH 6L	4	6	0 -0.010	12	0	35	±0.3	28	0 -0.2
LMCH 8L		8		15	-0.013	45		32	
LMCH 10L		10		19	55	39			
LMCH 12L		12		21	0	57		42	
LMCH 13L		13		23	-0.016	61		43	
LMCH 16L	5	16	0	28	0	70	±0.3	48	0 -0.2
LMCH 20L		20		32	0	80		54	
LMCH 25L		25		-0.012	40	-0.019		112	

Note) Since this model contains a synthetic resin retainer, do not use it at temperature exceeding 80°C.
If requiring a type equipped with a seal, indicate it when placing an order.

(Example) LMCH16L UU

_____ Seal attached on both ends of the nut

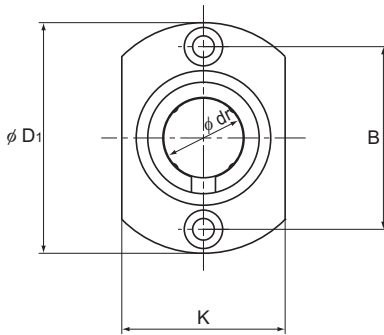

Models LMCH 6L to 13L

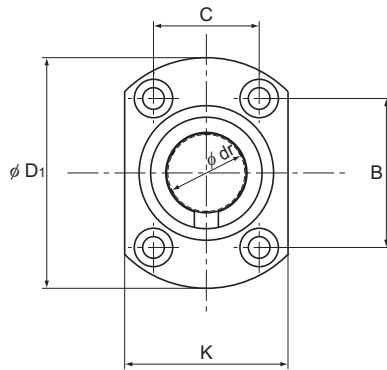

Models LMCH 16L to 25L

Unit: mm

	Length		D ₂	H	K	B	C	Mounting hole d ₁ × d ₂ × h	Flange	Eccentricity (max)	Radial clearance tolerance	Basic Load Rating		Mass
	I	Tolerance							perpendicularity			μm	C	
	15	±0.2	12	5	18	20	—	3.4 × 6 × 3.3	12	12	-5	324	529	26
	20		15		21	24	—		12		-5	431	784	41
	24.5		19		25	29	—	12	-5		588	1100	73	
	25.5		6	21	27	32	—	4.5 × 7.5 × 4.4	12		-5	657	1200	83
	27.5			23	29	33	—		12		-7	814	1570	106
	32			28	34	31	22		12		-7	1230	2350	180
	36			32	38	36	24		15	-9	1400	2750	219	
	52		8	40	46	40	32	5.5 × 9 × 5.4	15	15	-9	1560	3140	470

Note) If an oil hole is required, this can be indicated by appending "OH" to the end of the model number.
For further information, contact THK.

Models SC6 to 30

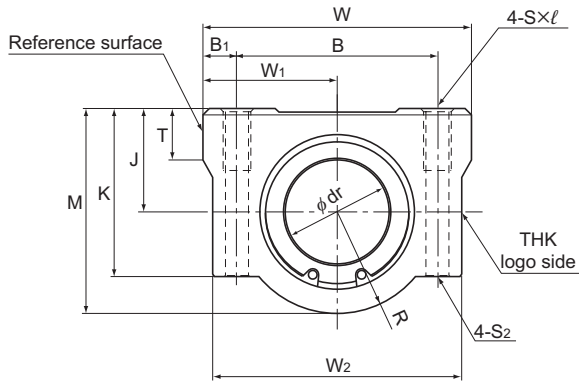

Models SC6 to 30

Model No.	Outer dimensions			LM casing dimensions						
	Height M	Width W	Length L	Mounting hole position			Tap S × l	Through bolt model No., S ₂	Center height J ±0.02	W ₁ ±0.02
				B	B ₁	C				
SC 6UU	18	30	25	20	5	15	M4 × 8	M3	9	15
SC 8UU	22	34	30	24	5	18	M4 × 8	M3	11	17
SC 10UU	26	40	35	28	6	21	M5 × 12	M4	13	20
SC 12UU	29	42	36	30.5	5.75	26	M5 × 12	M4	15	21
SC 13UU	30	44	39	33	5.5	26	M5 × 12	M4	15	22
SC 16UU	38.5	50	44	36	7	34	M5 × 12	M4	19	25
SC 20UU	42	54	50	40	7	40	M6 × 12	M5	21	27
SC 25UU	51.5	76	67	54	11	50	M8 × 18	M6	26	38
SC 30UU	59.5	78	72	58	10	58	M8 × 18	M6	30	39

Note) Since this model contains a synthetic resin retainer, do not use it at temperature exceeding 80°C.

A stainless steel Linear Bushing model LM-MG, which is highly corrosion resistant, can also be incorporated at your request.

Example of Model Number for Use in Combination with
Linear Bushing Units

Linear Bushing to be combined	Example of model No.	
Both end attached with seal	SC 13UU	Standard stock
Without seal	SC 13	Build to order
Made of stainless steel; both end attached with seal	SC 13MUU	Build to order

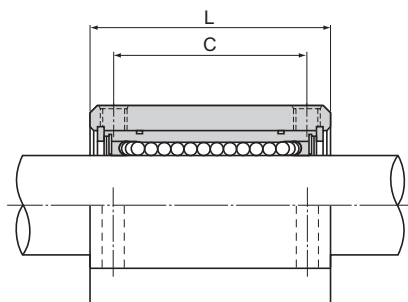

Unit: mm

							Model No. of Linear Bushing to be combined	Basic load rating		Unit
					Inscribed bore diameter			C	C ₀	Mass
K	W ₂	T	R	dr	Tolerance	N				
15	28	6	9	6	0 -0.009	LM6UU	206	265	34	
18	32	6	11	8		LM8UU	265	402	52	
22	37	8	13	10		LM10UU	373	549	92	
25	39	8	14	12		LM12UU	412	598	102	
26	41	8	15	13		LM13UU	510	775	123	
35	46	9	19.5	16		LM16UU	775	1180	189	
36	52	11	21	20	0 -0.010	LM20UU	863	1370	237	
41	68	12	25.5	25		LM25UU	980	1570	555	
49	72	15	29.5	30		LM30UU	1570	2750	685	

Note) If an oil hole is required, this can be indicated by appending "OH" to the end of the model number.
For further information, contact THK.

Models SC35 to 50

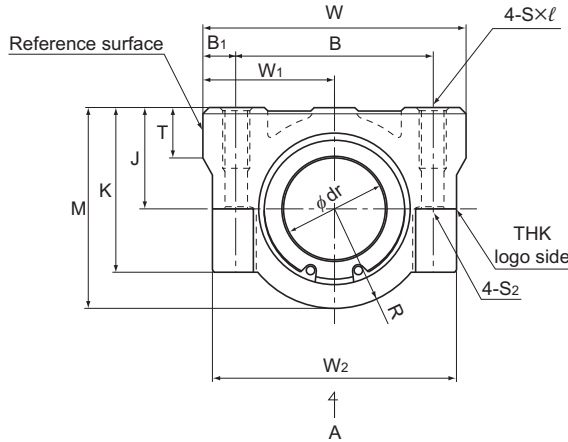

Models SC35 to 50

Model No.	Outer dimensions			LM casing dimensions							
	Height M	Width W	Length L	Mounting hole position			Tap S×ℓ	Through bolt model No., S ₂	Center height J ±0.02	W ₁ ±0.02	K
				B	B ₁	C					
SC 35UU	68	90	80	70	10	60	M8×18	M6	34	45	54
SC 40UU	78	102	90	80	11	60	M10×25	M8	40	51	62
SC 50UU	102	122	110	100	11	80	M10×25	M8	52	61	80

Note) Since this model contains a synthetic resin retainer, do not use it at temperature exceeding 80°C.

A stainless steel Linear Bushing model LM-MG, which is highly corrosion resistant, can also be incorporated at your request.
(Model SC50 does not include a stainless type.)

Example of Model Number for Use in Combination with
Linear Bushing Units

Linear Bushing to be combined	Example of model No.	
Both end attached with seal	SC 40UU	Standard stock
Without seal	SC 40	Build to order
Made of stainless steel; both end attached with seal	SC 40MUU	Build to order

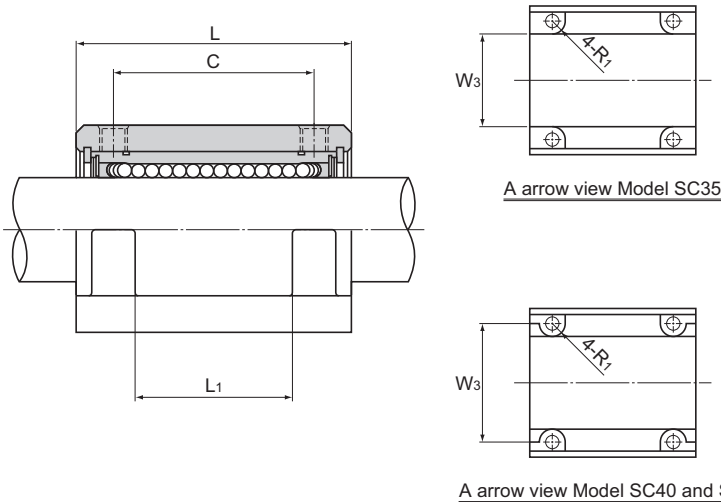

Unit: mm

	W ₂	W ₃	L ₁	T	R	R ₁	Inscribed bore diameter		Model No. of Linear Bushing to be combined	Basic load rating		Unit
							dr	Tolerance		C	C ₀	Mass g
										N	N	
	85	60	42	18	34	5	35	0 -0.012	LM35UU	1670	3140	1100
	96	80	44	20	38	8	40		LM40UU	2160	4020	1600
	116	100	64	25	50	8	50		LM50UU	3820	7940	3350

Note) If an oil hole is required, this can be indicated by appending "OH" to the end of the model number.
For further information, contact THK.

Model SL

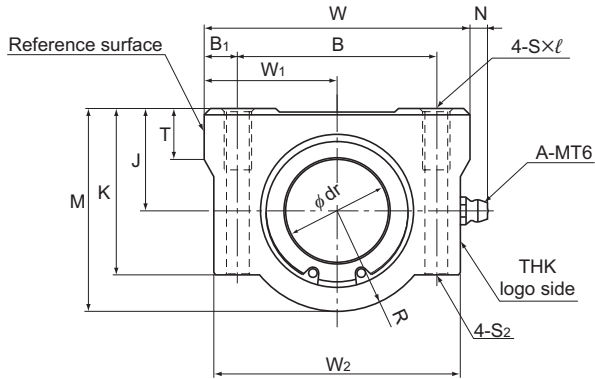

Model SL

Model No.	Outer dimensions			LM casing dimensions						
	Height M	Width W	Length L	Mounting hole position			Tap S × l	Through bolt model No. S ₂	Center height J ±0.02	W ₁ ±0.02
				B	B ₁	C				
SL 6UU	18	30	48	20	5	36	M4 × 8	M3	9	15
SL 8UU	22	34	58	24	5	42	M4 × 8	M3	11	17
SL 10UU	26	40	68	28	6	46	M5 × 12	M4	13	20
SL 12UU	29	42	70	30.5	5.75	50	M5 × 12	M4	15	21
SL 13UU	30	44	75	33	5.5	50	M5 × 12	M4	15	22
SL 16UU	38.5	50	85	36	7	60	M5 × 12	M4	19	25
SL 20UU	42	54	96	40	7	70	M6 × 12	M5	21	27
SL 25UU	51.5	76	130	54	11	100	M8 × 18	M6	26	38
SL 30UU	59.5	78	140	58	10	110	M8 × 18	M6	30	39

Note) Since this model contains a synthetic resin retainer, do not use it at temperature exceeding 80°C.

A stainless steel Linear Bushing model LM-MG, which is highly corrosion resistant, can also be incorporated at your request.

Example of Model Number for Use in Combination with
Linear Bushing Units

Linear Bushing to be combined	Example of model No.	
Both end attached with seal	SL 13UU	Standard stock
Without seal	SL 13	Build to order
Made of stainless steel; both end attached with seal	SL 13MUU	Build to order

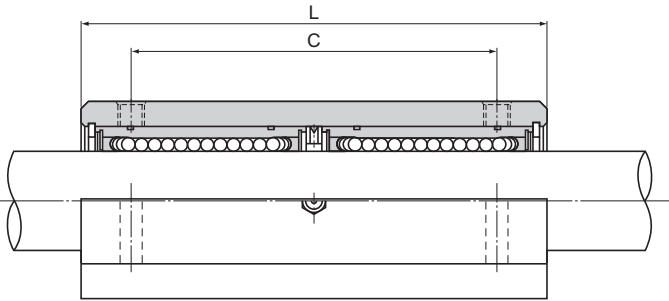

Unit: mm

	K	W ₂	T	R	N	Inscribed bore diameter		Model No. of Linear Bushing to be combined	Basic load rating		Unit
						dr	Tolerance		C	C ₀	Mass
	15	28	6	9	7	6	0 -0.009	LM6U	324	529	68
	18	32	6	11	7	8		LM8U	431	784	105
	22	37	8	13	7	10		LM10U	588	1100	185
	25	39	8	14	6.5	12		LM12U	657	1200	205
	26	41	8	15	6.5	13		LM13U	814	1570	242
	35	46	9	19.5	6	16		LM16U	1230	2350	403
	36	52	11	21	7	20	0 -0.010	LM20U	1400	2750	520
	41	68	12	25.5	4	25		LM25U	1560	3140	1120
	49	72	15	29.5	5	30		LM30U	2490	5490	1440

Model SH

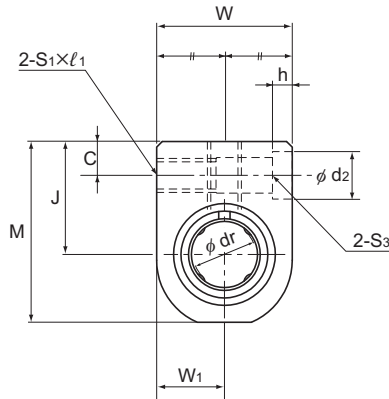

Model SH

Model No.	Outer dimensions			LM casing dimensions					
	Height M	Width W	Length L	Mounting hole position			Tap		Through bolt model No, S ₃
				B	B ₁	C	S ₁ × l ₁	S ₂ × l	
SH 3UU	14	10	13	—	8	3	M3 × 6	M3 × 5.5	M2
SH 4UU	16	12	15	—	10	3	M3 × 6	M3 × 6	M2
SH 5UU	18	14	17	—	12	3	M3 × 6	M3 × 6	M2
SH 6UU	22	16	24	18	9	5	M4 × 8	M4 × 8	M3
SH 8UU	26	20	27	20	10	5	M4 × 8	M5 × 8.5	M3
SH 10UU	32	26	35	27	15	6	M5 × 10	M6 × 9.5	M4
SH 12UU	34	28	35	27	15	6	M5 × 10	M6 × 9.5	M4
SH 13UU	36	30	36	28	16	6	M5 × 10	M6 × 9.5	M4
SH 16UU	42	36	40	32	18	6	M5 × 10	M6 × 10	M4
SH 20UU	49	42	44	36	22	7	M6 × 12	M6 × 12	M5

Note) Since this model contains a synthetic resin retainer, do not use it at temperature exceeding 80°C.

A stainless steel Linear Bushing model LM-MG, which is highly corrosion resistant, can also be incorporated at your request.

Example of Model Number for Use in Combination with Linear Bushing Units

Linear Bushing to be combined	Example of model No.	
Both end attached with seal	SH 13UU	Standard stock
Without seal	SH 13	Build to order
Made of stainless steel; both end attached with seal	SH 13MUU	Build to order

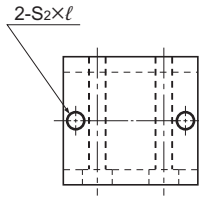
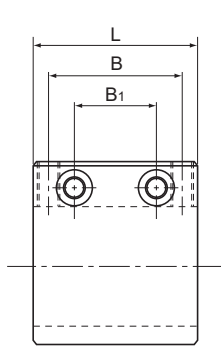

Top surface of models SH6 to SH20

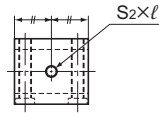

Top surface of models SH3 to SH5

Unit: mm

	Center height J ± 0.02	W_1 ± 0.02	d_2	h	Inscribed bore diameter		Model No. of Linear Bushing to be combined	Basic load rating		Unit	
					dr	Tolerance		C	C_0	Mass	
											N
	9	5	4.2	1.5	3	0 -0.008	LM3UU	88.2	108	4.5	
	10	6	4.2	1.5	4		LM4UU	88.2	127	7	
	11	7	4.2	1.5	5		LM5UU	167	206	11	
	14	8	6.5	3.3	6	0 -0.009	LM6UU	206	265	21	
	16	10	6.5	3.3	8		LM8UU	265	402	34	
	19	13	8	4.4	10		LM10UU	373	549	67	
	20	14	8	4.4	12		LM12UU	412	598	74	
	21	15	8	4.4	13		LM13UU	510	775	91	
	24	18	8	4.4	16		LM16UU	775	1180	157	
	28	21	9.5	5.4	20		0 -0.010	LM20UU	863	1370	206

Model SH-L

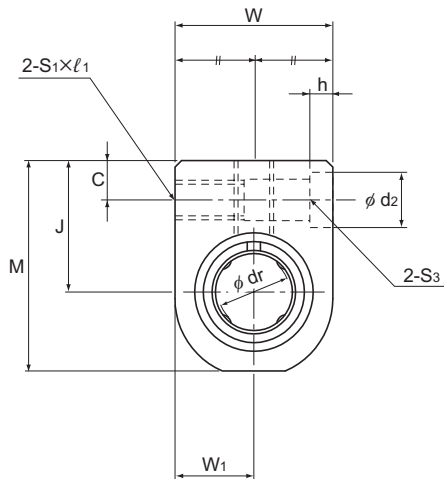

Model SH-L

Model No.	Outer dimensions			LM casing dimensions					
	Height M	Width W	Length L	Mounting hole position			Tap		Through bolt model No, S ₃
				B	B ₁	C	S ₁ × ℓ ₁	S ₂ × ℓ	
SH 3LUU	14	10	23	10	18	3	M3 × 6	M3 × 5.5	M2
SH 4LUU	16	12	27	14	22	3	M3 × 6	M3 × 6	M2
SH 5LUU	18	14	32	18	26	3	M3 × 6	M3 × 6	M2
SH 6LUU	22	16	40	20	30	5	M4 × 8	M4 × 8	M3
SH 8LUU	26	20	52	30	42	5	M4 × 8	M5 × 8.5	M3
SH 10LUU	32	26	60	36	50	6	M5 × 10	M6 × 9.5	M4
SH 12LUU	34	28	62	36	50	6	M5 × 10	M6 × 9.5	M4
SH 13LUU	36	30	66	40	54	6	M5 × 10	M6 × 9.5	M4
SH 16LUU	42	36	76	52	66	6	M5 × 10	M6 × 10	M4
SH 20LUU	49	42	86	58	72	7	M6 × 12	M6 × 12	M5

Note) Since this model contains a synthetic resin retainer, do not use it at temperature exceeding 80°C.

A stainless steel Linear Bushing model LM-MG, which is highly corrosion resistant, can also be incorporated at your request.

Example of Model Number for Use in Combination with Linear Bushing Units

Linear Bushing to be combined	Example of model No.	
Both end attached with seal	SH 13LUU	Standard stock
Without seal	SH 13L	Build to order
Made of stainless steel; both end attached with seal	SH 13MLUU	Build to order

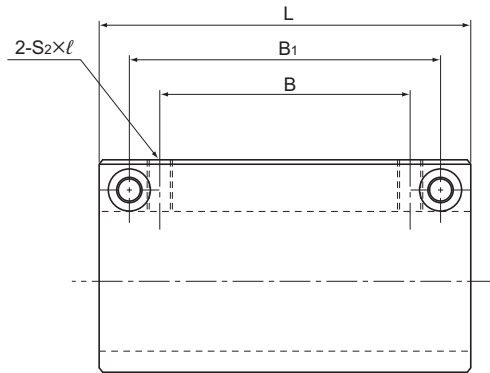

Unit: mm

	Center height J ±0.02	W ₁ ±0.02	d ₂	h	Inscribed bore diameter		Model No. of Linear Bushing to be combined	Basic load rating		Unit	
					dr	Tolerance		C	C ₀	Mass	
											N
	9	5	4.2	1.5	3	0 -0.008	LM3U	139	216	8.6	
	10	6	4.2	1.5	4		LM4U	139	254	14	
	11	7	4.2	1.5	5		LM5U	263	412	22	
	14	8	6.5	3.3	6		LM6U	324	529	37	
	16	10	6.5	3.3	8		LM8U	431	784	68	
	19	13	8	4.4	10	0 -0.009	LM10U	588	1100	125	
	20	14	8	4.4	12		LM12U	657	1200	140	
	21	15	8	4.4	13		LM13U	814	1570	176	
	24	18	8	4.4	16		LM16U	1230	2350	309	
	28	21	9.5	5.4	20		0 -0.010	LM20U	1400	2750	413

Model SK

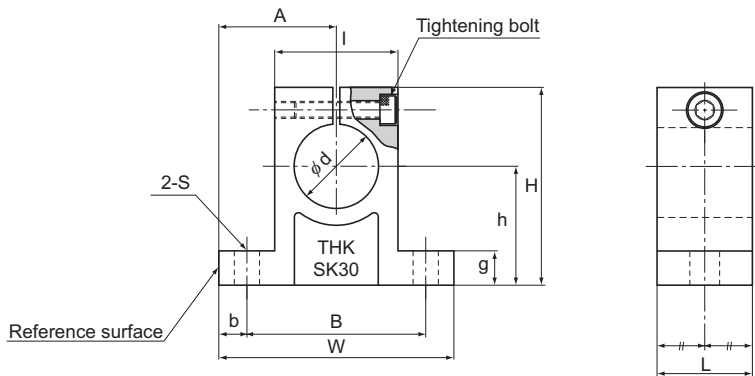

Unit: mm

Model No.	Main dimensions													Mass g
	H	W	L	B	S	Mounting bolt model No.	h ± 0.02	A ± 0.05	b	g	l	Shaft diameter d	Tightening bolt model No.	
SK 10	32.8	42	14	32	5.5	M5	20	21	5	6	18	10	M4	24
SK 12	37.5	42	14	32	5.5	M5	23	21	5	6	20	12	M4	30
SK 13	37.5	42	14	32	5.5	M5	23	21	5	6	20	13	M4	30
SK 16	44	48	16	38	5.5	M5	27	24	5	8	25	16	M4	40
SK 20	51	60	20	45	6.6	M6	31	30	7.5	10	30	20	M5	70
SK 25	60	70	24	56	6.6	M6	35	35	7	12	38	25	M6	130
SK 30	70	84	28	64	9	M8	42	42	10	12	44	30	M6	180
SK 35	83	98	32	74	11	M10	50	49	12	15	50	35	M8	270
SK 40	96	114	36	90	11	M10	60	57	12	15	60	40	M8	420

Standard LM Shafts

THK manufactures high quality, dedicated LM shafts for linear bushings.

(1) [Major materials]

SUJ2 (high-carbon chromium bearing steel)

THK5SP (THK standard material)

SUS440C equivalent

[Hardness] 58 to 64 HRC (SUJ2, THK5SP), 56 HRC or above (SUS440C or equivalent)

[Hardened layer depth] 0.8 to 2.5 mm (varies with shaft diameter)

[Surface roughness] Ra 0.4 or less

[Straightness of the LM shaft] 50 μ m/300 mm or less

(2) Precision-grade LM shafts with shaft diameter tolerance of g5 or h5 are also manufactured as standard.



Unit: mm

Model No.	Shaft diameter		Manufactured length L	
	d	Tolerance g6 μ m	Min length	Max length
SF 3	3	-2 -8	20	400
SF 4	4	-4 -12	20	400
SF 5	5		20	500
SF 6	6	-5 -14	20	1500
SF 8	8		20	1500
SF 10	10	-6 -17	30	1500
SF 12	12		30	1500
SF 13	13	-7 -20	40	3000
SF 16	16		40	3000
SF 20	20	-9 -25	40	3000
SF 25	25		50	3000
SF 30	30	-10 -29	60	3000
SF 35	35		70	3000
SF 38*	38	-12 -34	100	3000
SF 40	40		100	3000
SF 50	50	200	100	3000
SF 60*	60		200	3000
SF 80*	80	200	3000	
SF 100*	100	200	3000	

Note)*Made to order

[Dimensions of Hollow LM Shafts]

If a hollow LM shaft is required for purposes such as weight reduction, use the desired material from Table1 for the dimensions of hollow LM shafts that THK keeps in stock.

Table1 Dimensions of Hollow LM Shafts Unit: mm

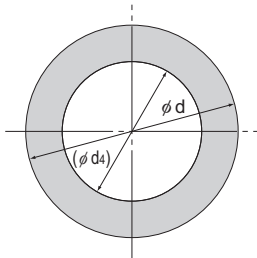

Supported model numbers	LM shaft outer diameter d	Inner diameter (ϕd_i)	Mass (kg/m)	
			Solid shaft	Hollow shaft
LM 8	8	3	0.4	0.34
LM 10	10	4	0.62	0.52
LM 12	12	6	0.89	0.67
LM 13	13	7	1.05	0.75
LM 16	16	9	1.59	1.09
LM 20	20	10	2.47	1.86
LM 20	20	14	2.47	1.26
LM 25	25	15	3.86	2.47
LM 30	30	16	5.56	3.98
LM 35	35	20	7.57	5.1
* LM 38	38	22	8.92	5.93
LM 40	40	22	9.88	6.89
LM 50	50	25	15.5	11.6
LM 60	60	32	22.3	16.0
* LM 80	80	52.5	39.6	22.5
* LM 100	100	67.5	61.8	33.7

Models marked with “*” are build-to-order items.

Model number coding

SF25 g6 -500L K

Model number

LM shaft outer diameter tolerance

Overall LM shaft length (in mm)

Special symbol*

no symbol: solid shaft K: standard hollow shaft
M: special material F: with surface treatment

*If two or more symbols are given, they are shown in an alphabetical order.

Specially Machined Types

THK also supports special machining processes such as tapping, milling, threading, through hole and end journals, as shown in the Fig.1 , at your request.

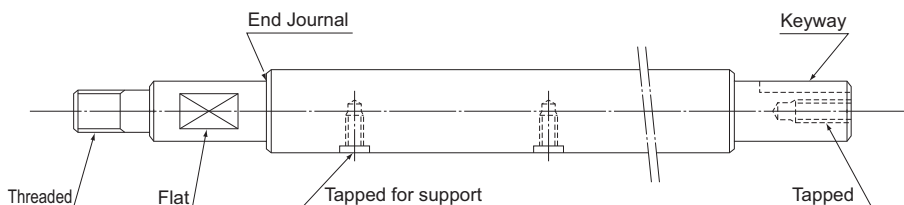

Fig.1

Dedicated Shafts

As the dedicated shafts for linear bushings come into direct contact with the ball bearings, the manufacturing tolerances for hardness, surface roughness, and the dimensional precision of the shaft are tight.

When manufacturing dedicated shafts, the surface hardness of the shaft will have a large impact on the overall service life. Check the following material and heat treatment specifications.

[Material]

Generally, the following materials are used for surface hardening through induction-hardening.

- SUJ2 (JIS G 4805: high-carbon chromium bearing steel)
- SK3 to 6 (JIS G 4401: carbon tool steel)
- S55C (JIS G 4051: carbon steel for machine structural use)

For special applications, martensite stainless steel SUS440C, which is corrosion resistant, may also be used.

[Hardness]

We recommend surface hardness of 58 HRC (\approx 653 HV) or higher. The depth of the hardened layer is determined by the size of the Linear Bushing; we recommend approximately 2 mm for general use.

[Surface Roughness]

To achieve smooth motion, the surface should preferably be finished to Ra0.40 or less.

Table of Rows of Balls and Masses for Clearance-adjustable Types and Open Types of the Linear Bushing

Shaft diameter	Clearance-adjustable Type			Open Type		
	Model No.	Rows of balls	Mass g	Model No.	Rows of balls	Mass g
6	LM 6-AJ	4	7.8	—	—	—
8	LM 8S-AJ	4	10	—	—	—
	LM 8-AJ	4	14.7	—	—	—
10	LM 10-AJ	4	29	—	—	—
12	LM 12-AJ	4	31	—	—	—
13	LM 13-AJ	4	42	LM 13-OP	3	34
16	LM 16-AJ	5(4)	68	LM 16-OP	4(3)	52
20	LM 20-AJ	5	85	LM 20-OP	4	69
25	LM 25-AJ	6(5)	216	LM 25-OP	5(4)	188
30	LM 30-AJ	6	245	LM 30-OP	5	210
35	LM 35-AJ	6	384	LM 35-OP	5	350
38	LM 38-AJ	6	475	LM 38-OP	5	400
40	LM 40-AJ	6	579	LM 40-OP	5	500
50	LM 50-AJ	6	1560	LM 50-OP	5	1340
60	LM 60-AJ	6	1820	LM 60-OP	5	1650
80	LM 80-AJ	6	4320	LM 80-OP	5	3750
100	LM 100-AJ	6	8540	LM 100-OP	5	7200
120	LM 120-AJ	8	14900	LM 120-OP	6	11600

Note)The numbers of ball rows in the table apply to types using a resin retainer. Those of types using a metal retainer are indicated in parentheses.

Assembling the Linear Bushing

[Inner Diameter of the Housing]

Table1 shows recommended housing inner-diameter tolerance for the Linear Bushing. When fitting the Linear Bushing with the housing, loose fit is normally recommended. If the clearance needs to be smaller, provide transition fit.

Table1 Housing Inner-diameter Tolerance

Type		Housing	
Model No.	Accuracy	Loose fit	Transition fit
LM	High accuracy grade (no symbol)	H7	J7
	Precision Grade (P)	H6	J6
LME	—	H7	K6, J6
LMF	High accuracy grade (no symbol)	H7	J7
LMK			
LMH			
LM-L			
LMF-L			
LMK-L			
LMH-L			
LMIF			
LMIK			
LMIH			
LMIF-L			
LMIK-L			
LMIH-L			
LMCF-L			
LMCK-L			
LMCH-L			

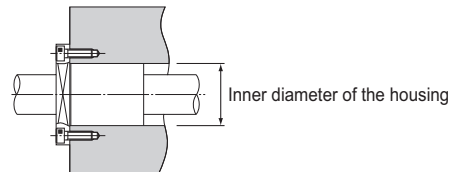

[Clearance between the Nut and the LM Shaft]

When using the Linear Bushing in combination with an LM shaft, use normal clearance in ordinary use and small gap if the clearance is to be minimized.

Note1) If the clearance after installation is to be negative, it is preferable not to exceed the radial clearance tolerance indicated in the specification table.

Note2) The shaft tolerance for Linear Bushing models SC, SL SH and SH-L falls under high accuracy grade (no symbol).

Table2 Shaft Outer-diameter Tolerance

Type		LM Shaft	
Model No.	Accuracy	Normal clearance	Small gap
LM	High accuracy grade (no symbol)	f6, g6	h6
	Precision Grade (P)	f5, g5	h5
LME	—	h7	k6
LMF	High accuracy grade (no symbol)	f6, g6	h6
LMK			
LMH			
LM-L			
LMF-L			
LMK-L			
LMH-L			
LMIF			
LMIK			
LMIH			
LMIF-L			
LMIK-L			
LMIH-L			
LMCF-L			
LMCK-L			
LMCH-L			

[Mounting the Nut]

Although the Linear Bushing does not require a large amount of strength for securing it in the axial direction, do not rely only on a press fit to support the nut. For the housing inner-diameter tolerance, see Table1 on **A4-112**.

- **Mounting a Standard Linear Bushing**

Example mountings are shown in Fig. 1 and Fig. 2. Use snap rings or stopper plates to secure linear bushings.

Securing the nut by pressing against the outer surface with one set screw as shown in Fig. 3 will cause the nut to be deformed.

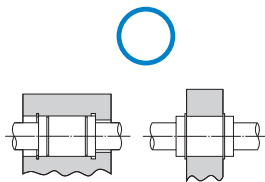

Fig. 1 Secured by snap ring

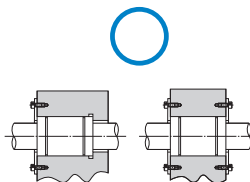

Fig. 2 Secured by stopper plate

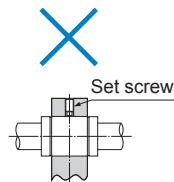

Fig. 3

■ Snap Ring for Installation

The snap ring types shown in Table 3 can be used for securing the standard Model LM.

Note 1) For models indicated with parentheses, use C-shape concentric snap rings.

Note 2) Table 3 commonly applies to models LM, LM-GA, LM-MG and LM-L.

Table 3 Types of Snap Rings

Model No.	Snap ring			
	For outer surface		For inner surface	
	Needle snap	C-shape snap	Needle snap	C-shape snap
LM 3	—	—	AR 7	—
LM 4	—	—	8	—
LM 5	WR 10	10	10	10
LM 6	12	12	12	12
LM 8	—	15	15	15
LM 8S	—	15	15	15
LM 10	19	19	19	19
LM 12	21	21	21	21
LM 13	23	22	23	—
LM 16	28	—	28	28
LM 20	32	—	32	32
LM 25	40	40	40	40
LM 30	45	45	45	45
LM 35	52	52	52	52
LM 38	—	56•58	57	—
LM 40	—	60	60	60
LM 50	—	80	80	80
LM 60	—	90	90	90
LM 80A	—	120	120	120
LM 100A	—	(150)	150	—
LM 120A	—	(180)	180	—

[Inserting the Nut]

When inserting the standard linear bushing into a housing, do not directly hit the seal or side plate. Use a jig to evenly drive in the nut, or place a flatter piece of metal on the nut and gently hit that. (See Fig. 4)

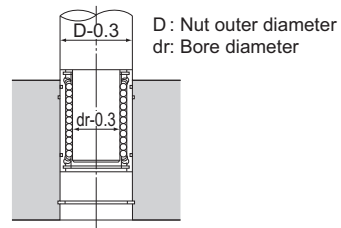

Fig. 4

Point of Design

Assembling the Linear Bushing

● Installing a Clearance-adjustable Type

To adjust the clearance of a clearance-adjustable type (-AJ), use a housing that allows adjustment of the nut outer diameter so as to facilitate the adjustment of the clearance between the Linear Bushing and the LM shaft. Positioning the slit of the Linear Bushing at an angle of 90° with the housing's slit will provide uniform deformation in the circumferential direction. (See Fig.5 .)

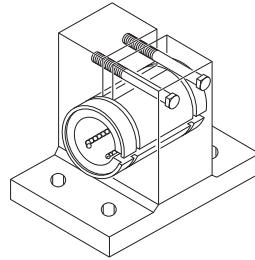

Fig.5

● Mounting an Open Type

For an open type (-OP), also use a housing that allows adjustment of the nut outer diameter as shown in Fig.6 .

Open types are normally used with a light preload. Be sure not to give an excessive preload.

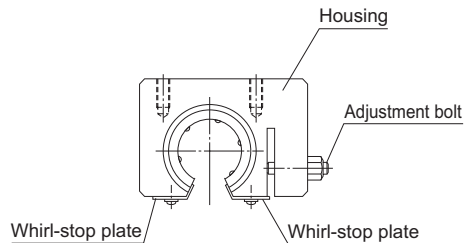

Fig.6

[Precautions on Installing an Open Three-ball-row Type Linear Bushing]

When installing an open three-ball-row type Linear Bushing, mount it while taking into account the load distribution as indicated in Fig.7 .

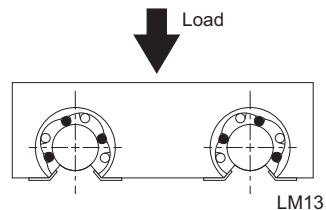
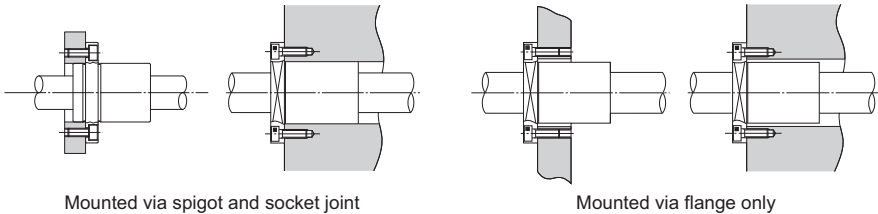

Fig.7

● Installing the Flanged Type

With models LMF, LMK, LMH, LMIF, LMCF, LMIK, LMCK, LMIH, and LMCH, the nut is integrated with a flange. Therefore, the linear bushing can be mounted only via the flange.



However, the Model LMJK must be mounted via a spigot and socket joint. Please do not mount using just the flange.



[Installing the LM Case Unit]

● Attaching Model SC (SL)

Models SC and SL can be affixed from either above or below using bolts. (See Fig. 8)

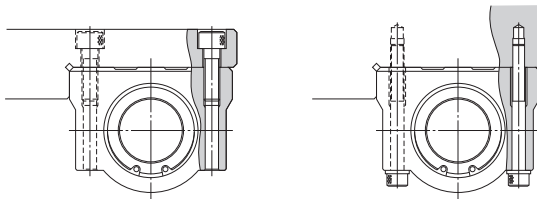

Fig. 8

● Attaching the Model SH (SH-L)

Models SH and SH-L can be affixed in any direction using bolts. (See Fig. 9)

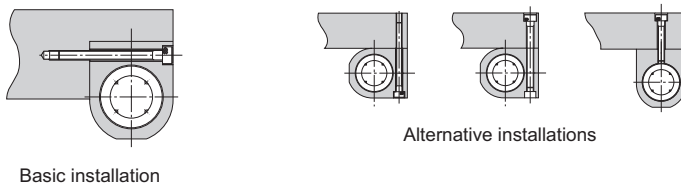

Fig. 9

Point of Design

Assembling the Linear Bushing

[Mounting the Shaft End Support]

Shaft end support model SK can easily be secured to the table using mounting bolts. Model SK enables the LM shaft to firmly be secured using tightening bolts.

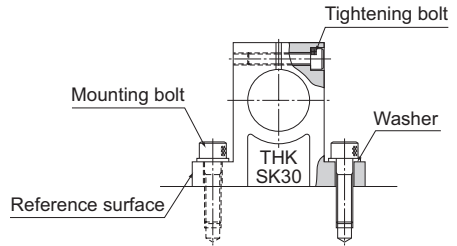

[Inserting the LM Shaft]

When inserting the LM shaft into the Linear Bushing, align the center of the shaft with that of the nut and gently insert the shaft straightforward into the nut. If the shaft is slanted while it is inserted, balls may fall off or the retainer may be deformed. (See Fig.10 .)

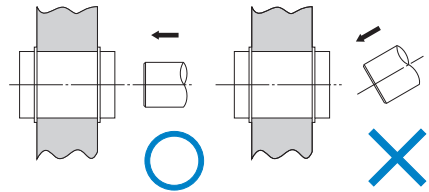

Fig.10

[When Under a Moment Load]

When using the Linear Bushing, make sure the load is evenly distributed on the whole ball raceway. In particular, if a moment load is applied, use two or more Linear Bushing units on the same LM shaft and secure an adequately large distance between the units.

If using the Linear Bushing under a moment load, also calculate the equivalent radial load and identify the correct model number. (See **A4-39** .)

[Rotational Use Not Allowed]

The Linear Bushing is not suitable for rotational use for a structural reason. (See Fig.11 .)

Forcibly rotating it may cause an unexpected accident.

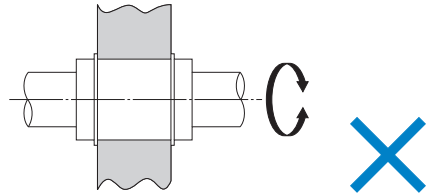

Fig.11

[Attaching Felt Seal Model FLM]

The felt seal can be press-fit into a housing finished to H7, but cannot be used as a stopper for preventing the Linear Bushing from coming off. Be sure to use the felt seal by attaching it as indicated in the Fig.12 .

Also make sure to impregnate the felt with sufficient lubricant before attaching it.

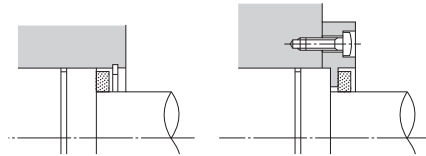

Fig.12

Lubrication

The Linear Bushing requires grease or oil as a lubricant for its operation.

[Grease Lubrication]

Before mounting the product onto the LM shaft, apply grease to each row of balls inside the Guide Ball Bushing.

Thereafter apply grease as necessary, in accordance with usage and other conditions noted above, or attach housing as shown in Fig. 1, or apply grease directly to the LM shaft.

We recommend using lithium soap-based grease No. 2.

[Oil Lubrication]

Apply the required amount of oil or grease-based lubricant onto the LM shaft and set it in the housing as shown in Fig. 1.

Commonly used lubricants include turbine oil, machine oil, and spindle oil.

In addition to the procedures described the above, an oil hole or grease nipple can also be used for lubrication. For further information, contact THK.

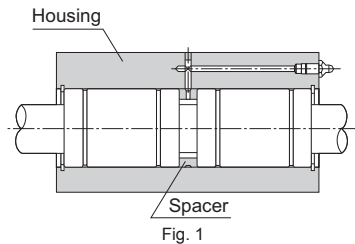

Material and Surface Treatment

For the Linear Bushing and the LM shaft, highly corrosion-resistant stainless steel types are available for some models.

Although the LM shaft can be surface treated, some types may not be suitable for the treatment. Contact THK for details.

Dust prevention

Entrance of dust or other foreign material into the Linear Bushing will cause abnormal wear or shorten the service life. When entrance of dust or other foreign material is a possibility, it is important to select effective seals and/or a dust-control device that meets the service environment conditions.

For the Linear Bushing, a special synthetic rubber seal that is highly resistant to wear and a felt seal (highly dust preventive with low seal resistance) are available as contamination protection accessories.

In addition, THK produces round bellows. Contact us for details.

Felt Seal Model FLM

Linear Bushing model LM series include types equipped with a special synthetic rubber seal (LM...UU, U). If desiring to have an additional contamination protection measure, or desiring to lower the seal resistance, use the felt seal model FLM. (See Table1)

[Dimensions of the Felt Seal]

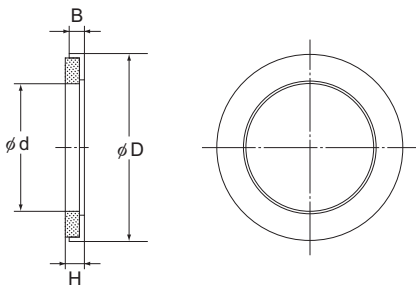

Table1 Major Dimensions of FLM

Unit: mm

Model No.	Main dimensions				Supported linear bushing model
	d	D	B	H	
FLM 6	6	12	2	2	LM 6
FLM 8	8	15	2	2	LM 8
FLM 10	10	19	3	3	LM 10
FLM 12	12	21	3	3	LM 12
FLM 13	13	23	3	3	LM 13
FLM 16	16	28	4	5	LM 16
FLM 20	20	32	4	5	LM 20
FLM 25	25	40	5	6	LM 25
FLM 30	30	45	5	6	LM 30
FLM 35	35	52	5	6	LM 35
FLM 38	38	57	5	6	LM 38
FLM 40	40	60	5	6	LM 40
FLM 50	50	80	10	11	LM 50
FLM 60	60	90	10	11	LM 60
FLM 80	80	120	10	11	LM 80
FLM 100	100	150	10	11	LM 100

Model Number Coding

Model number configurations differ depending on the model features. Refer to the corresponding sample model number configuration.

[Linear Bushing]

- LM, LME, LM-L, LMF, LMF-L, LMK, LMK-L, LMJK, LMJK-L, LMH, LMH-L, LMIF, LMIF-L, LMCFL-L, LMIK, LMIK-L, LMCK-L, LMIH, LMIH-L, LMCH-L, SC, SL, SH, SH-L

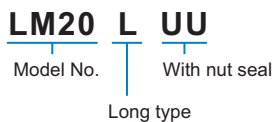

- LM-M, LM-MG, LMF-M, LMF-ML, LMK-M, LMK-ML, LMH-M, LMH-ML



- LM-GA, LM-MGA, LME-GA

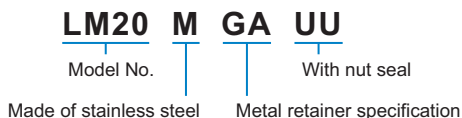

■Notes on Ordering

For high temperature applications, seals (symbol: UU) can be attached to both ends of the nut on linear bushes used with metal cages (symbol: A). However, cages without seals are recommended, since the seals are only heat-resistant to a temperature of 80°C.

[LM Shaft End Support]● **Model SK****SK20**

Model No.

[LM Shaft]● **Model SF****SF25 g6 -500L K**

Model No.

LM shaft outer
diameter toleranceOverall LM shaft length
(in mm)

Special symbol*

no symbol: solid shaft K: standard hollow shaft
M: special material F: with surface treatment

*If two or more symbols are given, they are shown in an alphabetical order.

*For information shaft diameters, permissible shaft diameter error and standard stock lengths, see **A4-109**.**[Felt Seal]**● **Model FLM****FLM 20**

Model No.

[Handling]

- (1) Disassembling each part may cause dust to enter the system or degrade mounting accuracy of parts. Do not disassemble the product.
- (2) Take care not to drop or strike the Linear Bushing. Doing so may cause injury or damage. Giving an impact to it could also cause damage to its function even if the product looks intact.
- (3) When handling the product, wear protective gloves, safety shoes, etc., as necessary to ensure safety.

[Precautions on Use]

- (1) Prevent foreign material, such as cutting chips or coolant, from entering the product. Failure to do so may cause damage.
- (2) If the product is used in an environment where cutting chips, coolant, corrosive solvents, water, etc., may enter the product, use bellows, covers, etc., to prevent them from entering the product.
- (3) Do not use the product at temperature of 80°C or higher. Exposure to higher temperatures may cause the resin/rubber parts to deform/be damaged.
- (4) If foreign material such as cutting chips adheres to the product, replenish the lubricant after cleaning the product.
- (5) Micro-strokes tend to obstruct oil film to form on the raceway in contact with the rolling element, and may lead to fretting corrosion. Take consideration using grease offering excellent fretting prevention. It is also recommended that a stroke movement corresponding to the length of the outer cylinder be made on a regular basis to make sure oil film is formed between the raceway and rolling element.
- (6) Do not use undue force when fitting parts (pin, key, etc.) to the product. This may generate permanent deformation on the raceway, leading to loss of functionality.
- (7) Insert the shaft straight through the opening. Inserting the shaft at an angle can introduce foreign matter, damage internal components, or cause balls to fall out.
- (8) Using this product with any balls removed may result in premature damage.
- (9) Please contact THK if any balls fall out; do not use the product if any balls are missing.
- (10) If an attached component is insufficiently rigid or mounted incorrectly, the bearing load will be concentrated at one location and performance will decline significantly. Make sure the housing and base are sufficiently rigid, the anchoring bolts are strong enough, and the component is mounted correctly.

[Lubrication]

- (1) Thoroughly wipe off anti-rust oil and feed lubricant before using the product.
- (2) Do not mix different lubricants. Mixing greases using the same type of thickening agent may still cause adverse interaction between the two greases if they use different additives, etc.
- (3) When using the product in locations exposed to constant vibrations or in special environments such as clean rooms, vacuum and low/high temperature, use the grease appropriate for the specification/environment.
- (4) To lubricate the product, apply lubricant directly to the raceway surface and execute a few preliminary strokes to ensure that the interior is fully lubricated.
- (5) The consistency of grease changes according to the temperature. Take note that the slide resistance of the Linear Bushing also changes as the consistency of grease changes.

- (6) After lubrication, the slide resistance of the Linear Bushing may increase due to the agitation resistance of grease. Be sure to perform a break-in to let the grease spread fully, before operating the machine.
- (7) Excess grease may scatter immediately after lubrication, so wipe off scattered grease as necessary.
- (8) The properties of grease deteriorate and its lubrication performance drops over time, so grease must be checked and added properly according to the use frequency of the machine.
- (9) The greasing interval varies depending on the use condition and service environment. Set the final lubrication interval/amount based on the actual machine.

[Storage]

When storing the Linear Bushing, enclose it in a package designated by THK and store it in a room while avoiding high temperature, low temperature and high humidity.

[Disposal]

Dispose of the product properly as industrial waste.



Guide Ball Bushing/Linear Bushing

THK General Catalog

Guide Ball Bushing/Linear Bushing

THK General Catalog

B Support Book

Features and Types	B 4-4	Precautions on Use	B 4-50
Features of the Guide Ball Bushing	B 4-4		
• Structure and Features	B 4-4		
• Examples of Changing the Linear Bushing to the Guide Ball Bushing ..	B 4-6		
Types of the Guide Ball Bushing	B 4-7		
• Types and Features	B 4-7		
Point of Selection	B 4-8		
Flowchart for Selecting a Guide Ball Bushing ..	B 4-8		
• Steps for Selecting a Guide Ball Bushing ..	B 4-8		
Rated Load and Nominal Life	B 4-9		
Precautions To Be Taken if an Eccentric Load Is Applied ..	B 4-12		
Mounting Procedure and Maintenance ..	B 4-13		
Assembling the Guide Ball Bushing	B 4-13		
Options	B 4-16		
Lubrication	B 4-16		
Dust prevention	B 4-16		
Model No.	B 4-17		
• Model Number Coding	B 4-17		
Precautions on Use	B 4-18		
Features and Types	B 4-20		
Features of the Linear Bushing	B 4-20		
• Structure and Features	B 4-20		
Types of the Linear Ball Bushing	B 4-22		
• Types and Features	B 4-22		
Classification Table	B 4-32		
Point of Selection	B 4-34		
Flowchart for Selecting a Linear Bushing ..	B 4-34		
• Steps for Selecting a Linear Bushing	B 4-34		
Rated Load and Nominal Life	B 4-35		
Precautions To Be Taken if an Eccentric Load Is Applied ..	B 4-38		
Mounting Procedure and Maintenance ..	B 4-39		
Assembling the Linear Bushing	B 4-39		
Options	B 4-46		
Lubrication	B 4-46		
Material and Surface Treatment	B 4-46		
Dust prevention	B 4-47		
Felt Seal Model FLM	B 4-47		
Model No.	B 4-48		
• Model Number Coding	B 4-48		

A Product Descriptions (Separate)

Features and Types	A4-4	Model LME	A4-48
Features of the Guide Ball Bushing	A4-4	Model LM-L	A4-50
• Structure and Features	A4-4	Model LMF	A4-52
• Examples of Changing the Linear Bushing to the Guide Ball Bushing ..	A4-6	Model LMF-M (Stainless Steel Type)	A4-54
Types of the Guide Ball Bushing	A4-7	Model LMF-L	A4-56
• Types and Features	A4-7	Model LMF-ML (Stainless Steel Type) ..	A4-58
Point of Selection	A4-8	Model LMK	A4-60
Flowchart for Selecting a Guide Ball Bushing ..	A4-8	Model LMK-M (Stainless Steel Type)	A4-62
• Steps for Selecting a Guide Ball Bushing ..	A4-8	Model LMK-L	A4-64
Rated Load and Nominal Life	A4-9	Model LMK-ML (Stainless Steel Type) ..	A4-66
Table of Equivalent Factors	A4-13	Model LMJK	A4-68
Precautions To Be Taken if an Eccentric Load Is Applied ..	A4-13	Model LMJK-L	A4-70
Accuracy Standards	A4-13	Model LMH	A4-72
Dimensional Drawing, Dimensional Table		Model LMH-M (Stainless Steel Type)	A4-74
Model LG	A4-14	Model LMH-L	A4-76
Point of Design	A4-16	Model LMH-ML (Stainless Steel Type) ..	A4-78
Assembling the Guide Ball Bushing	A4-16	Model LMIF	A4-80
Options	A4-19	Model LMIF-L	A4-82
Lubrication	A4-19	Model LMCF-L	A4-84
Dust prevention	A4-19	Model LMIK	A4-86
Model No.	A4-20	Model LMIK-L	A4-88
• Model Number Coding	A4-20	Model LMCK-L	A4-90
Precautions on Use	A4-21	Model LMIH	A4-92
Features and Types	A4-23	Model LMIH-L	A4-94
Features of the Linear Bushing	A4-23	Model LMCH-L	A4-96
• Structure and Features	A4-23	Models SC6 to 30	A4-98
Types of the Linear Ball Bushing	A4-24	Models SC35 to 50	A4-100
• Types and Features	A4-24	Model SL	A4-102
Classification Table	A4-34	Model SH	A4-104
Point of Selection	A4-36	Model SH-L	A4-106
Flowchart for Selecting a Linear Bushing ..	A4-36	Model SK	A4-108
• Steps for Selecting a Linear Bushing	A4-36	• Standard LM Shafts	A4-109
Rated Load and Nominal Life	A4-37	• Specially Machined Types	A4-110
Table of Equivalent Factors	A4-41	• Dedicated Shafts	A4-111
Precautions To Be Taken if an Eccentric Load Is Applied ..	A4-41	• Table of Rows of Balls and Masses for Clearance-adjustable Types and Open Types of the Linear Bushing	A4-111
Accuracy Standards	A4-41	Point of Design	A4-112
Dimensional Drawing, Dimensional Table		Assembling the Linear Bushing	A4-112
Model LM	A4-42	Options	A4-119
Model LM-GA (Metal Retainer Type)	A4-44	Lubrication	A4-119
Model LM-MG (Stainless Steel Type)	A4-46	Material and Surface Treatment	A4-119
		Dust prevention	A4-120
		Felt Seal Model FLM	A4-120
		Model No.	A4-121
		• Model Number Coding	A4-121
		Precautions on Use	A4-123

Features of the Guide Ball Bushing

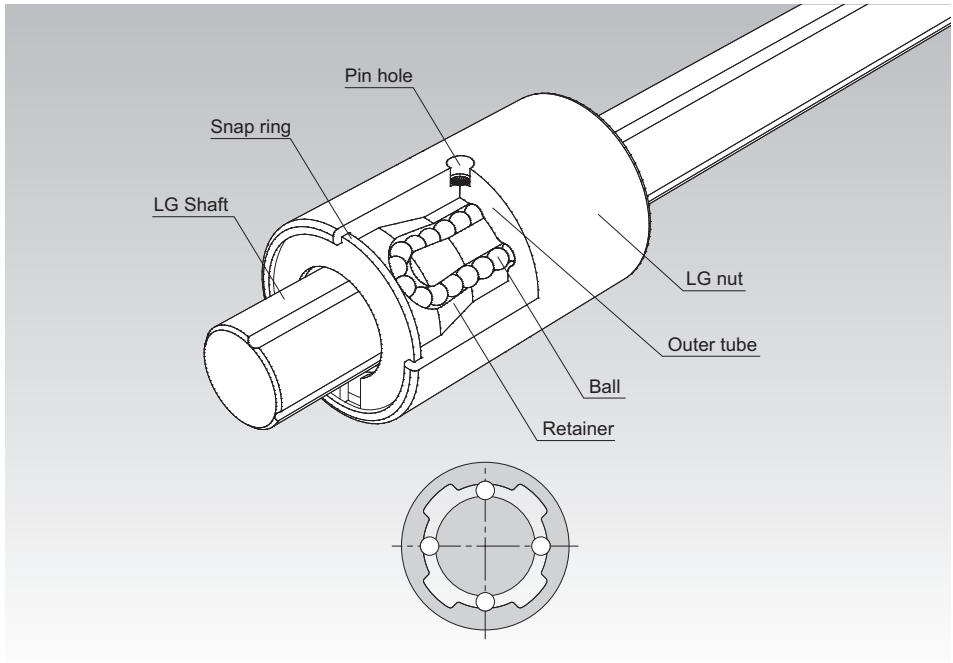

Fig.1 Structure of the Guide Ball Bushing model LG

Structure and Features

Since model LG has 4 rows of circular arc grooves (raceways), it does not need a mechanism to prevent the outer tube from rotating. In addition, its load rating is much larger than Linear Bushing model LM with the same dimensions. Therefore, replacing the Linear Bushing with the Guide Ball Bushing will reduce the size and cost of the guide unit and extend the service life.

Features and Types

Features of the Guide Ball Bushing

[Higher Load Rating than the Linear Bushing]

Since model LG ensures an R contact through the use of circular arc grooves for ball contact, it achieves a load rating more than twice that of point-contact Linear Bushing model LM with the same size.

[A Rotation Stopper is Unnecessary Because of Raceways]

Since model LG has circular arc grooves, it does not need a rotation stopper required for Linear Bushing model LM, and allows the machine design to be compact.

[Interchangeable in Dimensions with Linear Bushing Model LM]

Since the outer tube of model LG has the same outer diameter and length as that of Linear Bushing model, LM, it is possible to replace Linear Bushing model LM with Guide Ball Bushing model LG as assemblies.

[Various Combinations of Nut and Shaft are Available (Any Combination is Allowed)]

As with the Linear Bushing, any combination of the LG nut and the LG shaft of model LG is allowed.

Examples of Changing the Linear Bushing to the Guide Ball Bushing

[Advantage of using the Guide Ball Bushing 1: Longer service life]

Since model LG has a rated load more than 2.4 times the Linear Bushing with the same dimensions, replacing the Linear Bushing with model LG will increase the service life by more than 13.8 times.

Table1 Comparison of the service life between Guide Ball Bushing mode LG and Linear Bushing model LM

Model No.	Basic dynamic load rating: C [N]	Load rating ratio	Service life ratio
LG4S	335	3.8 times	54.8 times
LM4	88.2		
LG6S	494	2.4 times	13.8 times
LM6	206		
LG8S	796	3.0 times	27.0 times
LM8	265		

[Advantage of using the Guide Ball Bushing 2: Smaller machine size]

Since the Linear Bushing is not suitable for applications where a load in the rotational direction is applied, it is necessary to use two or more Linear Bushing units in parallel or have a rotation stopper mechanism even under conditions where a torque is not applied. In contrast, the Guide Ball Bushing, which has a structure containing four rows of circular arc grooves, is operable with a single shaft and therefore contributes to downsizing the machine, unless an excessive load is applied.

Achieves a load carrying capacity approximately three times the Linear Bushing in a half space

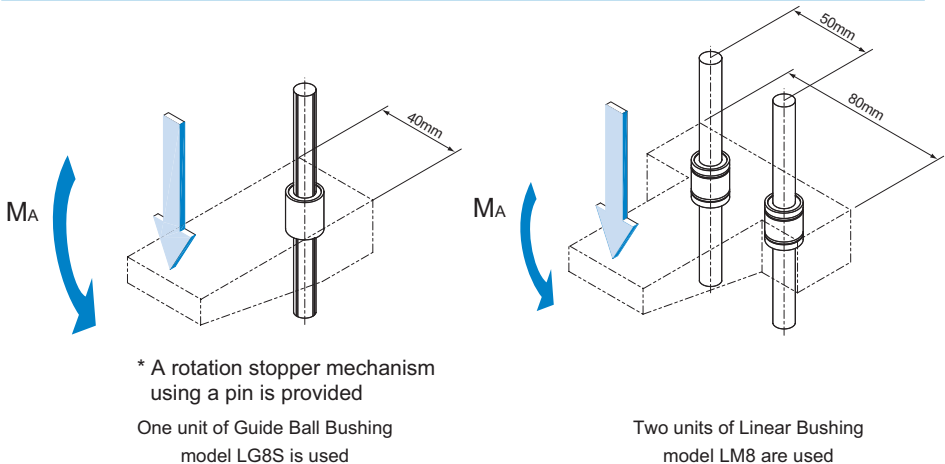

Table2 Comparison of the permissible moment between Guide Ball Bushing mode LG and Linear Bushing model LM

Model No.	Permissible moment: M_A [N·m]
One unit of LG8S is used	1.46
Two units of LM8 are used	0.45

Types of the Guide Ball Bushing

Types and Features

Model LG-S

Specification Table⇒ [A4-14](#)

In this type, the diameter and the length of the LG nut are the same as that of Linear Bushing model LM. This type is dimensionally interchangeable with model LM.

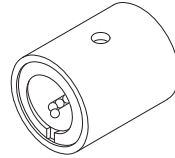

Model LG-L

Specification Table⇒ [A4-14](#)

Model LG-L is a long type in which the overall length of the LG nut is longer than that of model LG-S to increase the load carrying capacity.

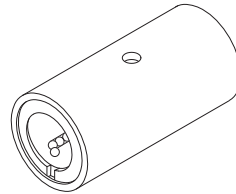

Flowchart for Selecting a Guide Ball Bushing

Steps for Selecting a Guide Ball Bushing

The following flowchart should be used as a guide for selecting a Guide Ball Bushing.

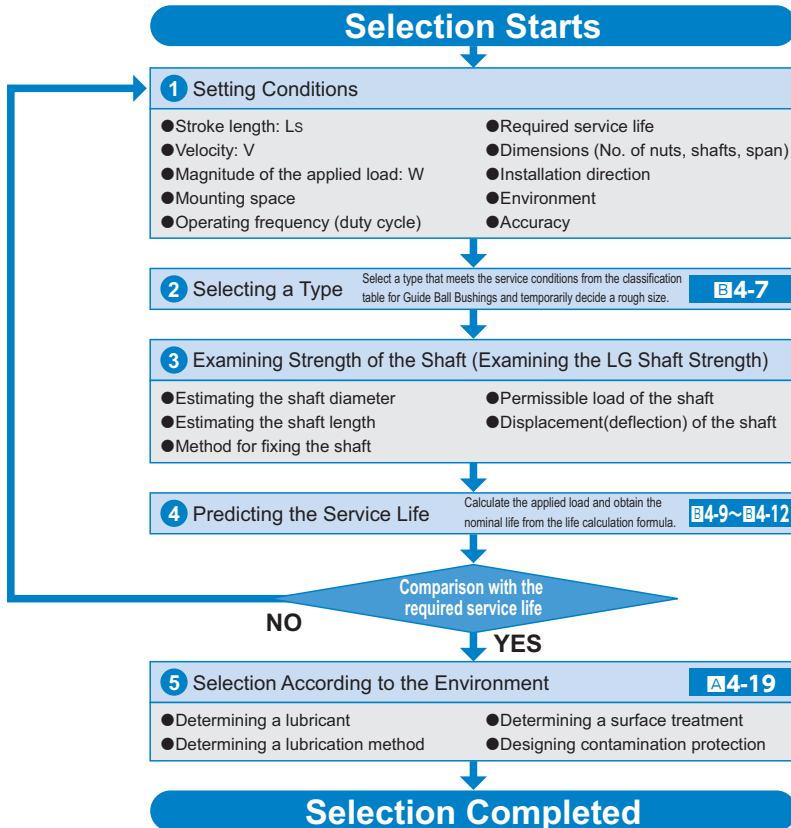

Rated Load and Nominal Life

[Load Rating]

The rated load of the Guide Ball Bushing varies according to the position of balls in relation to the load direction. The basic load ratings indicated in the specification tables each indicate the value when one row of balls receiving a load are directly under the load.

If the Guide Ball Bushing is mounted so that two rows of balls evenly receive the load in the load direction, the rated load changes as shown in Table1.

Table1 Rated load of the Guide Ball Bushing

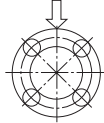
Rows of balls	Ball position	Load Rating
4 rows		$1.41 \times C$

Note: For specific values for "C" above, see the respective specification table.

[Calculating the Nominal Life]

The nominal life of the THK guide ball bushing is defined as 50 km. The nominal life (L_{10}) is calculated from the basic dynamic load rating (C) and the load acting on the guide ball bushing (P_c) using the following formula.

$$L_{10} = \left(\frac{C}{P_c} \right)^3 \times 50 \quad \dots\dots(1)$$

L_{10}	: Nominal life	(km)
C	: Basic dynamic load rating	(N)
P_c	: Calculated load	(N)

*This nominal life formula may not apply if the length of the stroke is less than or equal to twice the length of the nut.

When comparing the nominal life (L_{10}), you must take into account whether the basic dynamic load rating was defined based on 50 km or 100 km. Convert the basic dynamic load rating based on ISO 14728-1 as necessary.

ISO-regulated basic dynamic load rating conversion formula:

$$C_{100} = \frac{C_{50}}{1.26}$$

C_{50}	: Basic dynamic load rating based on a nominal life of 50 km
C_{100}	: Basic dynamic load rating based on a nominal life of 100 km

[Calculating the Modified Nominal Life]

During use, a guide ball bushing may be subjected to vibrations and shocks as well as fluctuating loads, which are difficult to detect. In addition, the surface hardness of the raceways, the operating temperature, and having blocks arranged directly behind one another will have a decisive impact on the service life. Taking these factors into account, the modified nominal life (L_{10m}) can be calculated according to the following formula (2).

• Modified factor α

$$\alpha = \frac{f_H \cdot f_T \cdot f_c}{f_w}$$

α	: Modified factor	
f_H	: Hardness factor	(see Fig.1 on B4-11)
f_T	: Temperature factor	
f_c	: Contact factor	(see Table2 on B4-12)
f_w	: Load factor	(see Table 3 on B4-12)

• Modified nominal life L_{10m}

$$L_{10m} = \left(\alpha \times \frac{C}{P_c} \right)^3 \times 50 \quad \dots\dots(2)$$

L_{10m}	: Modified nominal life	(km)
C	: Basic dynamic load rating	(N)
P_c	: Calculated load	(N)

● **When a Moment Load is Applied to a Single Nut or Two Nuts in Close Contact with Each Other**

When a moment load is applied to a single nut or two nuts in close contact with each other, calculate the equivalent radial load at the time the moment is applied.

$$P_u = K \cdot M$$

P_u : Equivalent radial load (N)
(with a moment applied)

K : Equivalent factors
(see Table4 to Table5 on **A4-13**)

M : Applied moment (N·mm)

However, " P_u " is assumed to be within the basic static load rating (C_0).

● **When a Moment Load and a Radial Load are Simultaneously Applied**

When a moment and a radial load are applied simultaneously, calculate the service life based on the sum of the radial load and the equivalent radial load.

■ **f_H : Hardness Factor**

To maximize the load capacity of the Guide Ball Bushing, the hardness of the raceways needs to be between 58 to 64 HRC.

If the hardness is lower than this range, the basic dynamic load rating and the basic static load rating decrease. Therefore, it is necessary to multiply each rating by the respective hardness factor (f_H).

Normally, $f_H = 1.0$ since the Guide Ball Bushing has sufficient hardness.

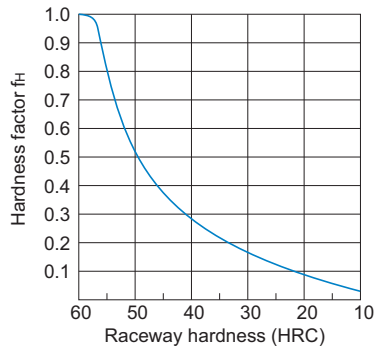

Fig.1 Hardness Factor (f_H)

■ **f_T : Temperature Factor**

The temperature of the environment where the Guide Ball Bushing is used must be 80°C or below. Therefore, adopt a temperature factor $f_T = 1.0$.

The Guide Ball Bushing does not support high temperature. Therefore, if the environment temperature exceeds 80°C, it is necessary to use another product.

■ f_c : Contact Factor

When multiple nuts are used in close contact with each other, their linear motion is affected by moments and mounting accuracy, making it difficult to achieve uniform load distribution. In such applications, multiply the basic load rating (C) and (C₀) by the corresponding contact factor in Table2.

Note) If uneven load distribution is expected in a large machine, take into account the respective contact factor indicated in Table2.

Table2 Contact Factor (f_c)

Number of nuts in close contact with each other	Contact factor f_c
2	0.81
3	0.72
4	0.66
5	0.61
Normal use	1

■ f_w : Load Factor

In general, reciprocating machines tend to experience vibrations or impacts during operation, and it is extremely difficult to accurately determine the vibrations generated during high-speed operation and impacts during frequent starts and stops. Therefore, when the actual load applied to a guide ball bushing cannot be obtained, or when speed and vibrations have a significant influence, divide the basic dynamic load rating (C) by the corresponding load factor in Table 3, which has been empirically obtained.

Table 3 Load Factor (f_w)

Vibrations/ impact	Speed(V)	f_w
Faint	Very low $V \leq 0.25\text{m/s}$	1 to 1.2
Weak	Slow $0.25 < V \leq 1\text{m/s}$	1.2 to 1.5
Medium	Medium $1 < V \leq 2\text{m/s}$	1.5 to 2
Strong	High $V > 2\text{m/s}$	2 to 3.5

[Calculating the Service Life Time]

When the nominal life (L_{10}) has been obtained, if the stroke length and the number of reciprocations per minute are constant, the service life time is obtained using the following equation.

$$L_h = \frac{L_{10} \times 10^3}{2 \times \ell_s \times n_1 \times 60}$$

L_h : Service life time (h)

ℓ_s : Stroke length (m)

n_1 : Number of reciprocations per minute (min^{-1})

Precautions To Be Taken if an Eccentric Load Is Applied

Model LG achieves a much higher load-carrying capacity in receiving the eccentric load (moment and torque) than Linear Bushing model LM because of 4 rows of raceways. However, under conditions where the eccentric load is larger, the product may result in poor operation or early failure. In such cases, we recommend using Ball Spline model LBS or LT, both of which have larger load-carrying capacities (see **B3-4** onward).

Assembling the Guide Ball Bushing

[Inner Diameter of the Housing]

Table1 shows recommended housing inner-diameter tolerance for the Guide Ball Bushing. When fitting the Guide Ball Bushing with the housing, loose fit is normally recommended. If the clearance needs to be smaller, provide transition fit.

Table1 Housing Inner-diameter Tolerance

General conditions	H6
If the accuracy does not need to be very high	H7

[Mounting the Nut]

Although the Guide Ball Bushing does not require a large amount of strength for securing it in the LG shaft direction, do not support the nut only with driving fitting. For the housing inner-diameter tolerance, see Table1.

● Mounting model LG using a pin

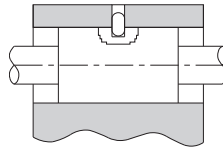

● Mounting model LG as with the conventional Linear Bushing

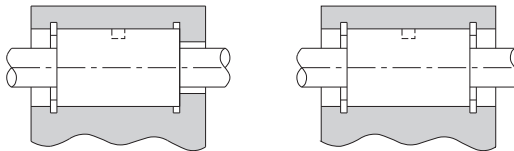

Snap Ring

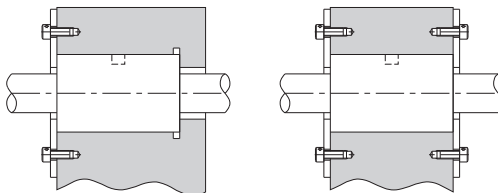

Stopper Plate

■Snap Ring for Installation

To secure the Guide Ball Bushing model LG, snap rings indicated in Table2 are available.

Table2 Types of Snap Rings

Model No.	Snap ring	
	For inner surface	
	Needle snap ring	C-shape snap ring
LG 4	8	—
LG 6	12	12
LG 8	15	15

■Set Screws Not Allowed

Securing the nut by pressing the outer surface with one set screw as shown in Fig.1 will cause the nut to be deformed.

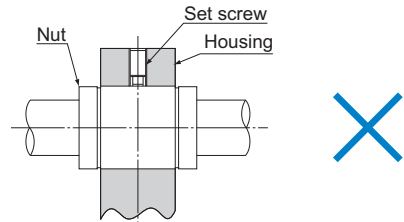

Fig.1

[Incorporating the Nut]

When incorporating the Guide Ball Bushing into a housing, use a jig and drive in the nut, or use a flatter plate and gently hit the nut, instead of directly hitting the side plate or the seal. (see Fig.2).

Unit: mm

Model No.	dr	Tolerance
LG 4S/LG 4L	3.6	-0.1 -0.3
LG 6S/LG 6L	5.6	
LG 8S/LG 8L	7.5	

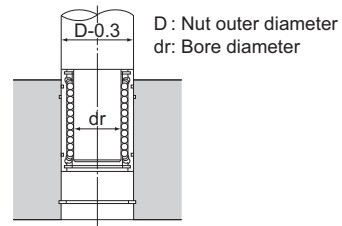

Fig.2

[Inserting the LG Shaft]

When inserting the LG shaft into the Guide Ball Bushing, align the center of the shaft with that of the nut and gently insert the shaft straightforward into the nut. If the shaft is slanted while it is inserted, balls may fall off or the retainer may be deformed (see Fig.3).

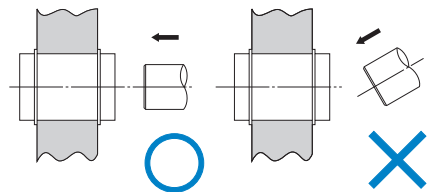

Fig.3

Mounting Procedure and Maintenance

Assembling the Guide Ball Bushing

[When Under a Moment Load]

When using the Guide Ball Bushing, make sure that the load is evenly distributed on the whole ball raceway. In particular, if a moment load is applied, use two or more Guide Ball Bushing units on the same LG shaft and secure an adequately large distance between the units.

If using the Guide Ball Bushing under a moment load, also calculate the equivalent radial load and identify the correct model number. (See [B4-11](#).)

Lubrication

The Guide Ball Bushing requires grease or oil as a lubricant for its operation.

[Grease Lubrication]

Before mounting the product onto the LG shaft, apply grease to each row of balls inside the Guide Ball Bushing.

Thereafter apply grease as necessary, in accordance with usage and other conditions noted above, or attach housing as shown in Fig.1, or apply grease directly to the LG shaft.

We recommend using lithium soap-based grease No. 2.

[Oil Lubrication]

To lubricate, apply lubricant to the LG shaft one drop at a time, as needed, or attach housing as shown in Fig.1, in the same manner as when lubricating with grease.

Commonly used lubricants include turbine oil, machine oil, and spindle oil.

In addition to the procedures described the above, an oil hole or grease nipple can also be used for lubrication. For further information, contact THK.

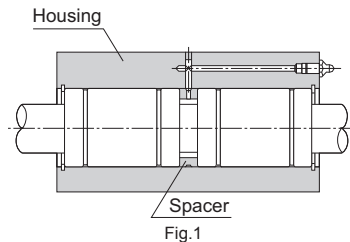

Dust prevention

Entrance of dust or other foreign material into the Guide Ball Bushing will cause abnormal wear or shorten the service life. When entrance of dust or other foreign material is a possibility, it is important to select effective seals and/or dust-control device that meets the service environment conditions.

In addition, THK produces round bellows. Contact us for details.

Model Number Coding

Model number configurations differ depending on the model features. Refer to the corresponding sample model number configuration.

[Guide Ball Bushing]

Estimates and orders should be made for LG shafts alone or LG nuts alone in principle.

A set consisting of an LG shaft and an LH nut is also available if desired by the customer. Contact THK for details.

● Models LG-S and LG-L

- LG shaft only

LG4 -100L

Model No.
of LG shaft

Overall LG shaft length (in mm)

- LG nut only

LG4S

Model No. of LG nut

- Combination of
LG shaft and LG nut

2 LG4S +100L

Model No.
of LG nut

Overall LG shaft length (in mm)

Number of LG nuts on one shaft
(no symbol for one nut)

A special radial clearance, designated grease application (standard product is applied with antirust oil only), and surface treatment (THK AP-C treatment, THK AP-CF treatment, THK AP-HC treatment) are also available. Contact THK for details.

Precautions on Use

Guide Ball Bushing

[Handling]

- (1) Disassembling each part may cause dust to enter the system or degrade mounting accuracy of parts. Do not disassemble the product.
- (2) Take care not to drop or strike the Guide Ball Bushing. Doing so may cause injury or damage. Giving an impact to it could also cause damage to its function even if the product looks intact.
- (3) When handling the product, wear protective gloves, safety shoes, etc., as necessary to ensure safety.

[Precautions on Use]

- (1) Prevent foreign material, such as cutting chips or coolant, from entering the product. Failure to do so may cause damage.
- (2) If the product is used in an environment where cutting chips, coolant, corrosive solvents, water, etc., may enter the product, use bellows, covers, etc., to prevent them from entering the product.
- (3) Do not use the product at temperature of 80°C or higher. Exposure to higher temperatures may cause the resin/rubber parts to deform/be damaged.
- (4) If foreign material such as cutting chips adheres to the product, replenish the lubricant after cleaning the product.
- (5) Micro-strokes tend to obstruct oil film to form on the raceway in contact with the rolling element, and may lead to fretting corrosion. Take consideration using grease offering excellent fretting prevention. It is also recommended that a stroke movement corresponding to the length of the outer cylinder be made on a regular basis to make sure oil film is formed between the raceway and rolling element.
- (6) Do not use undue force when fitting parts (pin, key, etc.) to the product. This may generate permanent deformation on the raceway, leading to loss of functionality.
- (7) Insert the shaft straight through the opening. Inserting the shaft at an angle can introduce foreign matter, damage internal components, or cause balls to fall out.
- (8) Using this product with any balls removed may result in premature damage.
- (9) Please contact THK if any balls fall out; do not use the product if any balls are missing.
- (10) If an attached component is insufficiently rigid or mounted incorrectly, the bearing load will be concentrated at one location and performance will decline significantly. Make sure the housing and base are sufficiently rigid, the anchoring bolts are strong enough, and the component is mounted correctly.

[Lubrication]

- (1) Thoroughly wipe off anti-rust oil and feed lubricant before using the product.
- (2) Do not mix different lubricants. Mixing greases using the same type of thickening agent may still cause adverse interaction between the two greases if they use different additives, etc.
- (3) When using the product in locations exposed to constant vibrations or in special environments such as clean rooms, vacuum and low/high temperature, use the grease appropriate for the specification/environment.
- (4) To lubricate the product, apply lubricant directly to the raceway surface and execute a few preliminary strokes to ensure that the interior is fully lubricated.
- (5) The consistency of grease changes according to the temperature. Take note that the slide resistance of the Guide Ball Bushing also changes as the consistency of grease changes.

Precautions on Use

- (6) After lubrication, the slide resistance of the Guide Ball Bushing may increase due to the agitation resistance of grease. Be sure to perform a break-in to let the grease spread fully, before operating the machine.
- (7) Excess grease may scatter immediately after lubrication, so wipe off scattered grease as necessary.
- (8) The properties of grease deteriorate and its lubrication performance drops over time, so grease must be checked and added properly according to the use frequency of the machine.
- (9) The greasing interval varies depending on the use condition and service environment. Set the final lubrication interval/amount based on the actual machine.

[Assembling the LG Nut with the LG Shaft of the Guide Ball Bushing]

- (1) When assembling the LG nut with the LG shaft, align the position of the balls inside the LG nut with the position of the groove of the LG shaft, then insert the LG shaft into the LG nut straight-forward and gradually. If the LG shaft is tilted when it is inserted, balls may bounce out or damage the circulating part.
- (2) If the LG shaft is stuck in the middle of insertion, do not force it into the nut. Instead, but pull it out first, re-check the ball position and the LG shaft groove position, and then insert it straight-forward and gradually.
- (3) After assembling the LG nut with the LG shaft, check that the LG nut or the LG shaft smoothly moves. If the shaft was forced into the nut, function could be lost even if the product looks intact.

[Storage]

When storing the Guide Ball Bushing, enclose it in a package designated by THK and store it in a room while avoiding high temperature, low temperature and high humidity.

[Disposal]

Dispose of the product properly as industrial waste.

Features of the Linear Bushing

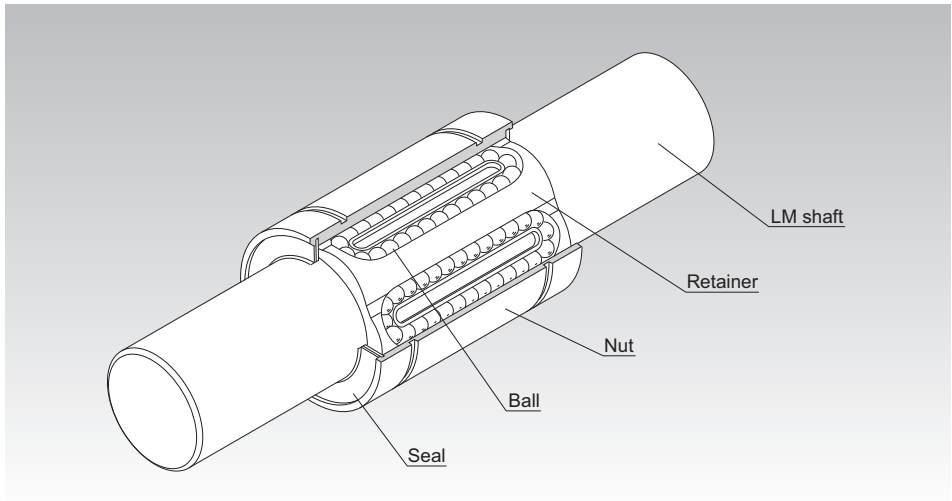

Fig.1 Structure of Linear Bushing Model LM···UU

Structure and Features

The linear bushing is a linear motion product that is used in combination with a cylindrical LM shaft. The ball bearings in the load area offer point contact with the LM shaft. This allows straight motion with minimal friction resistance and therefore smooth motion.

High-carbon chromium bearing steel is used for the nut, and the outer and inner surfaces are ground and heat-treated.

Linear bushings are used for medical equipment, packing equipment, and lightweight OA equipment that is not subject to vibration, shock, etc.

However, they cannot be used for applications in which loads are applied in a rotational direction.

Features and Types

Features of the Linear Bushing

[Interchangeability]

The linear bushing and LM shaft are interchangeable, allowing for use in any combination.

[Low Noise]

A molded resin retainer is incorporated into the standard type in order to prevent the balls from falling out. This also provides silent and smooth operation.

[Wide Array of Types]

A wide array of types are available, such as the Standard Type, Clearance-adjustable Type, Open Type, Long Type, Fitted Flange Type, and Flanged Linear Bushing, allowing the user to select a type that suits the intended application.

Types of the Linear Ball Bushing

Types and Features

Standard Type

Specification Table⇒ [A4-42](#)/[A4-44](#)/[A4-46](#)/[A4-48](#)

The most standard type with a wide range of applications.

- Model LM SUJ2 Type
This product series has commonly used dimensions
- Model LM-GA SUJ2 Type
Features the Model LM-GA metal retainer
- Model LM-MG SUS Type
- Model LME SUJ2 Type
This product series has dimensions commonly used in Europe

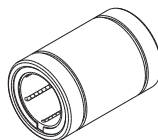

Standard Type

Clearance-adjustable Type

Specification Table⇒ [A4-42](#)/[A4-44](#)/[A4-46](#)/[A4-48](#)

A standard nut with a slit in the direction of the LM shaft.

The clearance between the LM shaft and housing can be adjusted by installing the shaft to a housing with an adjustable inner diameter.

- Models LM-AJ/LM-GA-AJ/LME-AJ... Made of SUJ2
- Model LM-MG-AJ SUS Type

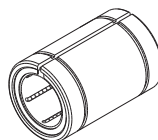

Clearance-adjustable Type

Open Type

Specification Table⇒ [A4-42](#)/[A4-44](#)/[A4-46](#)/[A4-48](#)

The nut features a cut equal to the width of one row of ball bearings (50° to 80°).

This enables it to be used even in locations where the LM shaft is supported by a column or fulcrum. In addition, the clearance can be adjusted.

- Models LM-OP/LM-GA-OP/LME-OP... Made of SUJ2
- Model LM-MGA-OP SUS Type

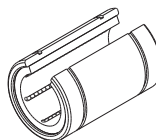

Open Type

Features and Types

Types of the Linear Ball Bushing

Long Type

Incorporates two standard type retainers, giving it a large net rated load.

Model LM-L SUJ2 Type

Specification Table⇒ **A** 4-50

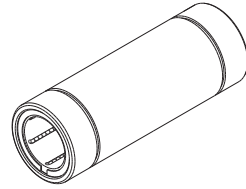

Long Type

Flanged Type (Round)

Easy to mount because the spline nut can be directly attached to the housing.

Model LMF SUJ2 Type

Model LMF-M SUS Type

Specification Table⇒ **A** 4-52/ **A** 4-54

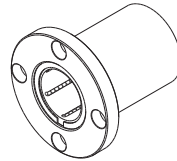

Flanged Type (Round)

Flanged Type (Round) - Long

Incorporates two standard type retainers, giving it a large net rated load.

Model LMF-L SUJ2 Type

Model LMF-ML SUS Type

Specification Table⇒ **A** 4-56/ **A** 4-58

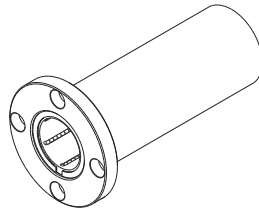

Flanged Type (Round) - Long

Flanged Type (Square)

Features a Model LMF flange that has been flattened on four sides.

The lower core height compared to circular flanges allows for more compact designs.

Model LMK SUJ2 Type

Model LMK-M SUS Type

Specification Table⇒ [A4-60/A4-62](#)

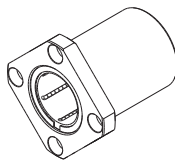

Flanged Type (Square)

Flanged Type (Square) - Long

Incorporates two standard type retainers, giving it a large net rated load.

Model LMK-L SUJ2 Type

Model LMK-ML SUS Type

Specification Table⇒ [A4-64/A4-66](#)

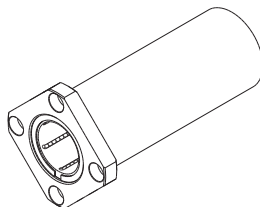

Flanged Type (Square) - Long

Lightweight Flanged Type (Square) NEW

Features a flange made using high strength plastic.

Weighs less than metal flanges.

Mounting this type to moving parts reduces the overall weight.

Model LMJK SUJ2 Type

Specification Table⇒ [A4-68](#)

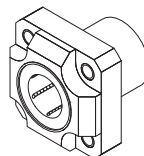

Lightweight Flanged Type (Square)

Lightweight Flanged Type (Square) - Long NEW Specification Table⇒ [A4-70](#)

Incorporates two standard type retainers, giving it a large net rated load.

Model LMJK-L SUJ2 Type

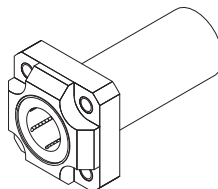

Lightweight Flanged Type (Square) - Long

Features and Types

Types of the Linear Ball Bushing

Flanged Type (Cut Flange)

Features a Model LMF flange that has been flattened on two sides.

The lower core height compared to square flanges allows for more compact designs.

The rows of bearings are aligned so that a load from one of the flattened sides will be supported by two rows of bearings.

Model LMH SUJ2 Type

Model LMH-M SUS Type

Specification Table⇒ [A4-72/A4-74](#)

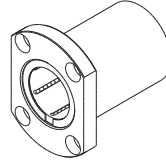

Flanged Type (Cut Flange)

Flanged Type (Cut Flange) - Long

Incorporates two standard type retainers, giving it a large net rated load.

Model LMH-L SUJ2 Type

Model LMH-ML SUS Type

Specification Table⇒ [A4-76/A4-78](#)

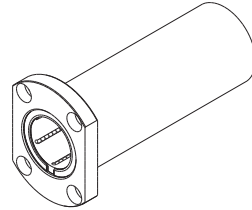

Flanged Type (Cut Flange) - Long

Fitted Flanged Type (Round)

Specification Table⇒ **A4-80**

Since the fitted part is short, the linear bushing tends not to protrude into the other side, so space is saved on the side opposite the mounting.

Model LMIF SUJ2 Type

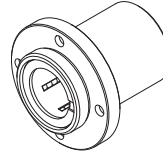

Fitted Flanged Type (Round)

Fitted Flanged Type (Round) - Long

Specification Table⇒ **A4-82**

Model LMIF - Long.

Incorporates two standard type retainers, giving it a large net rated load.

Model LMIF-L SUJ2 Type

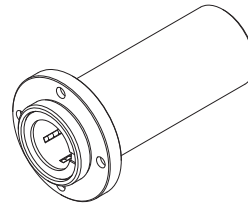

Fitted Flanged Type (Round) - Long

Center Flanged Type (Round) - Long

Specification Table⇒ **A4-84**

As work pieces can be mounted around the center of the nut, the load can be distributed and spaced evenly on either side of the flange. Ideal for making the stroke even in both directions.

Model LMCF-L SUJ2 Type

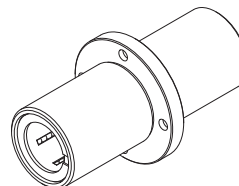

Center Flanged Type (Round) - Long

Features and Types

Types of the Linear Ball Bushing

Fitted Flanged Type (Square)

Specification Table⇒ [A-4-86](#)

The flange is similar to the Model LMIF, but flattened in four places.

The lower core height compared to circular flanges allows for more compact designs.

Model LMIK SUJ2 Type

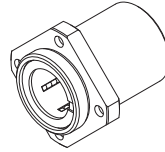

Fitted Flanged Type (Square)

Fitted Flanged Type (Square) - Long

Specification Table⇒ [A-4-88](#)

Incorporates two standard type retainers, giving it a large net rated load.

Model LMIK-L SUJ2 Type

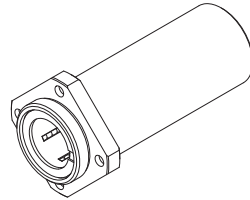

Fitted Flanged Type (Square) - Long

Center Flanged Type (Square) - Long

Specification Table⇒ [A-4-90](#)

As work pieces can be mounted around the center of the nut, the load can be distributed and spaced evenly on either side of the flange. Ideal for making the stroke even in both directions.

Model LMCK-L SUJ2 Type

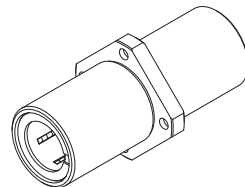

Center Flanged Type (Square) - Long

Fitted Flanged Type (Ovular)

Specification Table⇒ [A4-92](#)

Features a Model LMIF flange that has been flattened on two sides.

The lower core height compared to square flanges allows for more compact designs.

The rows of bearings are aligned so that a load from one of the flattened sides will be supported by two rows of bearings.

Model LMIH SUJ2 Type

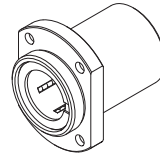

Fitted Flanged Type (Ovular)

Fitted Flanged Type (Ovular) - Long

Specification Table⇒ [A4-94](#)

Incorporates two standard type retainers, giving it a large net rated load.

Model LMIH-L SUJ2 Type

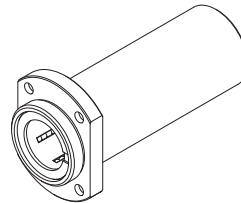

Fitted Flanged Type (Ovular) - Long

Center Flanged Type (Ovular) - Long

Specification Table⇒ [A4-96](#)

As work pieces can be mounted around the center of the nut, the load can be distributed and spaced evenly on either side of the flange. Ideal for making the stroke even in both directions.

Model LMCH-L SUJ2 Type

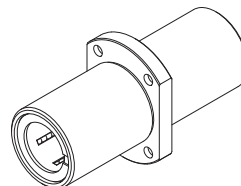

Center Flanged Type (Ovular) - Long

Features and Types

Types of the Linear Ball Bushing

Linear Bushing Model SC

It is a case unit where the standard type of Linear Bushing is incorporated into a small, light-weight aluminum casing. This model can easily be mounted simply by securing it to the table with bolts.

Specification Table⇒ **A**4-98

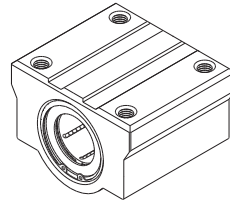

Linear Bushing Model SC

Linear Bushing (Long) Model SL

A case unit that features two standard linear bushings embedded within an aluminum casing.

Specification Table⇒ **A**4-102

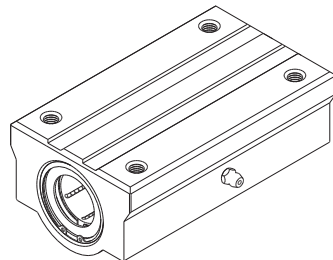

Linear Bushing (Long) Model SL

Linear Bushing Model SH

Specification Table⇒ [A4-104](#)

It is a case unit where the standard type of Linear Bushing is incorporated into a smaller and lighter aluminum casing than model SC. This model allows even more compact design than model SC. It also has flexibility in mounting orientation. Additionally, it is structured so that two rows of balls receive the load from the top of the casing, allowing a long service life to be achieved.

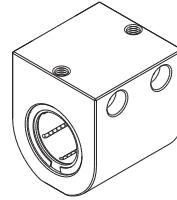

Linear Bushing Model SH

Linear Bushing (Long) Model SH-L

Specification Table⇒ [A4-106](#)

A long version of model SH, this model is a case unit that contains two units of the standard type Linear Bushing in an aluminum casing.

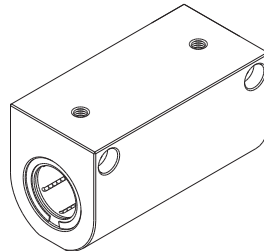

Linear Bushing (Long) Model SH-L

Features and Types

Types of the Linear Ball Bushing

Standard LM Shafts

LM shafts for use with the high quality linear bushing model LM series.

Specification Table⇒ [A-4-109](#)



Standard LM Shafts

Build-to-order LM Shafts

Machined shaft ends available upon request.

Specification Table⇒ [A-4-111](#)



Build-to-order LM Shafts

LM Shaft End Support Model SK

A lightweight aluminum fulcrum for securing an LM shaft.

Allows the LM shaft to be secured without having to machine the LM shaft ends.

Specification Table⇒ [A-4-108](#)

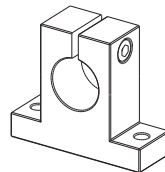

LM Shaft End Support Model SK

Classification Table

Linear Bushing

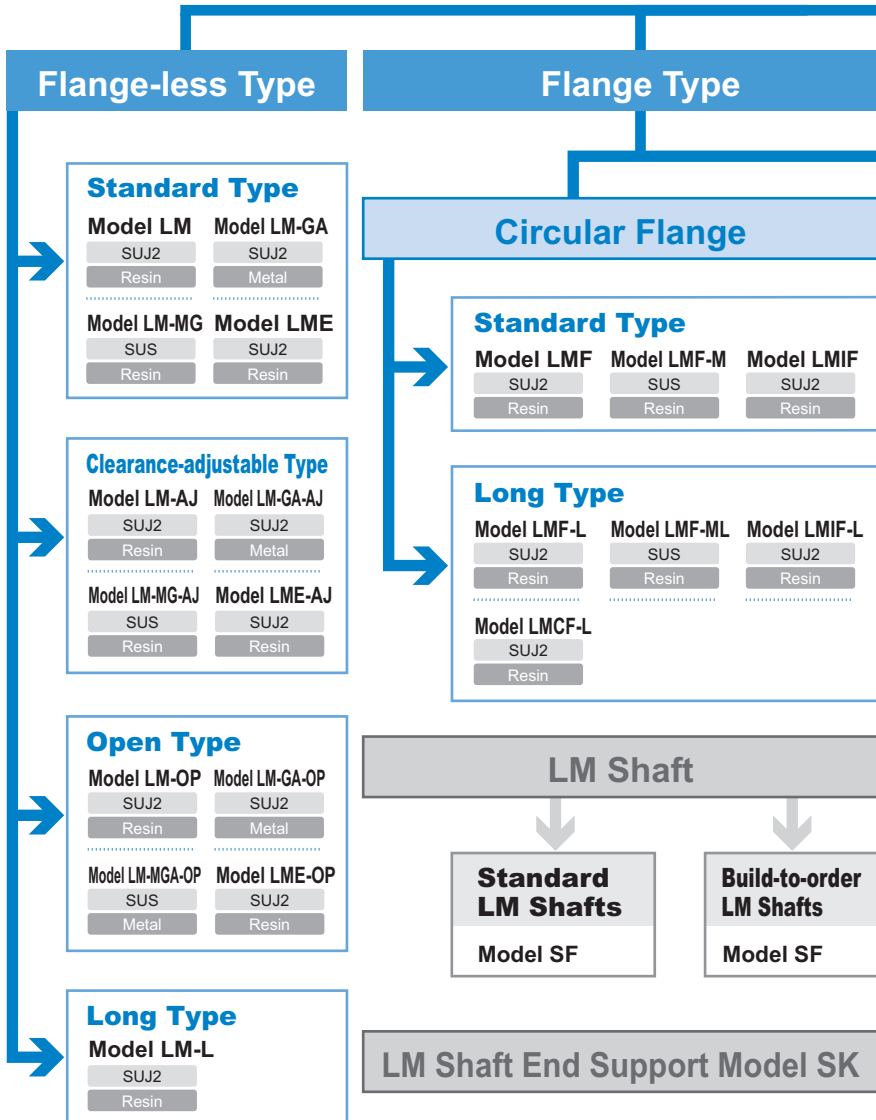

Features and Types

Classification Table

Type of Material

Model No.

- Nut Material
 - SUJ2 (High-carbon Chromium Bearing Steel)
 - SUS (Martensite Stainless Steel)
- Retainer Material
- Case Material

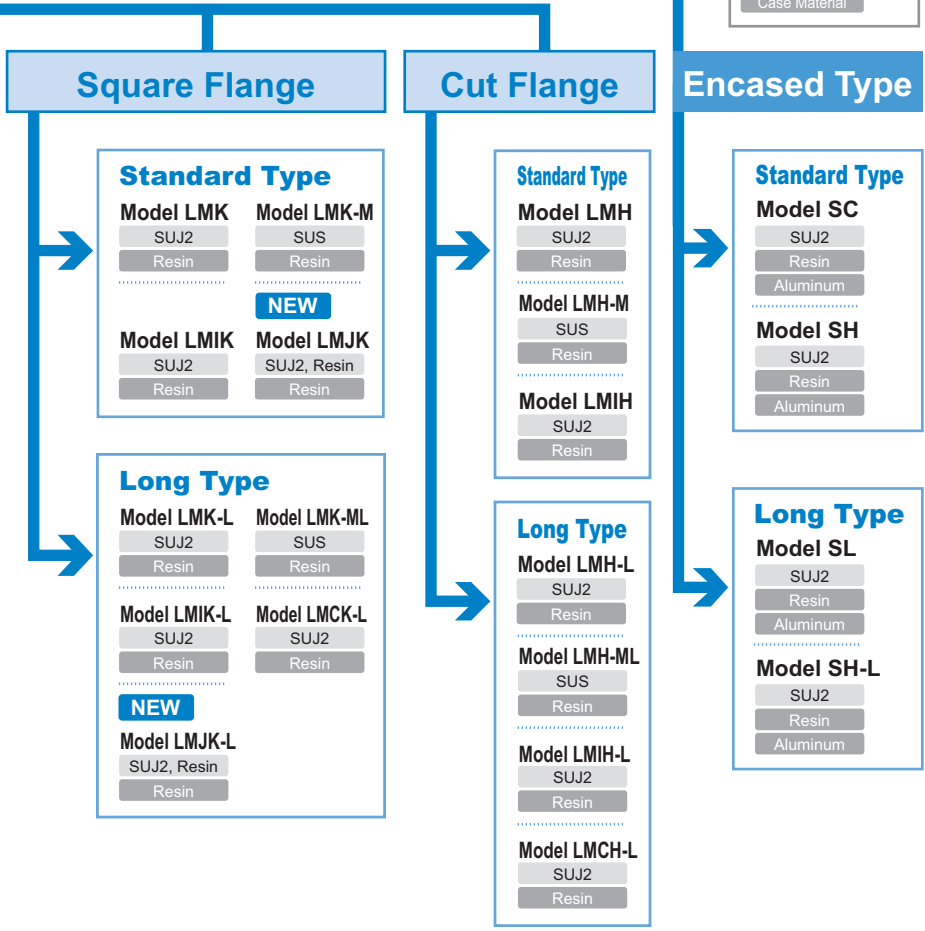

Flowchart for Selecting a Linear Bushing

Steps for Selecting a Linear Bushing

The following flowchart should be used as a guide for selecting a Linear Bushing.

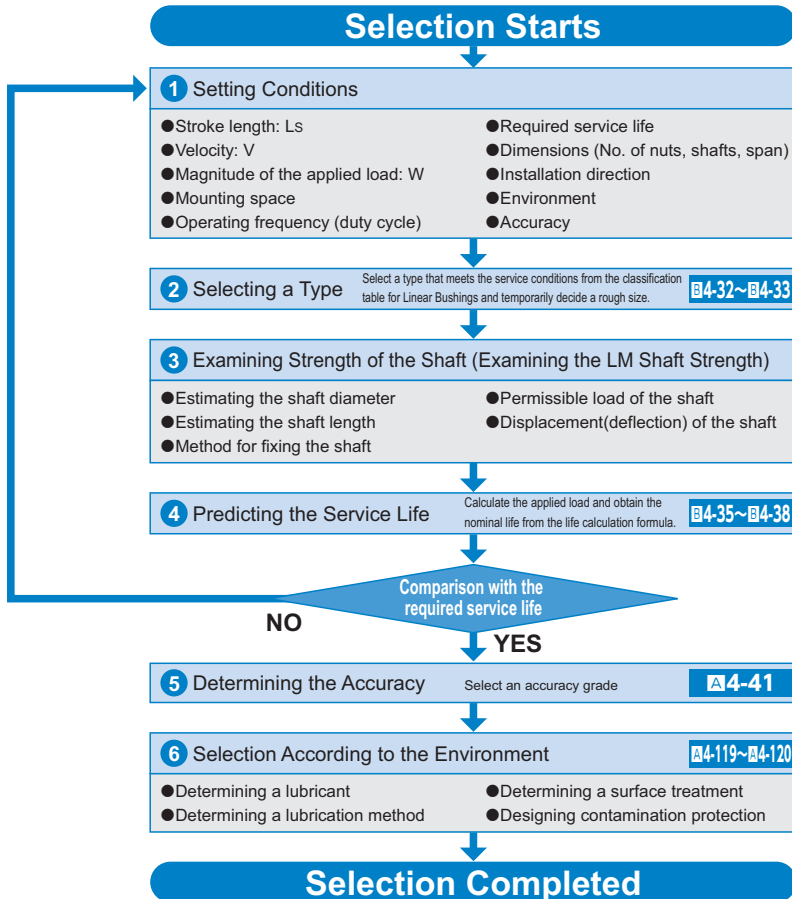





Rated Load and Nominal Life

[Load Rating]

The rated load of the Linear Bushing varies according to the position of balls in relation to the load direction. The basic load ratings indicated in the specification tables each indicate the value when one row of balls receiving a load are directly under the load.

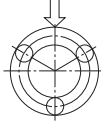
If the Linear Bushing is mounted so that two rows of balls evenly receive the load in the load direction, the rated load changes as shown in Table1.

Table1 Rated load of the Linear Bushing

Rows of balls	Ball position	Load Rating
3 rows		$1 \times C$
4 rows		$1.41 \times C$
5 rows		$1.46 \times C$
6 rows		$1.28 \times C$
8 rows		$1.25 \times C$

For specific values for "C" above, see the respective specification table.

[Calculating the Nominal Life]

The nominal life of the THK linear bushing is defined as 50 km. The nominal life (L_{10}) is calculated from the basic dynamic load rating (C) and the load acting on the linear bushing (P_c) using the following formula.

$$L_{10} = \left(\frac{C}{P_c} \right)^3 \times 50 \quad \dots\dots(1)$$

L_{10}	: Nominal life	(km)
C	: Basic dynamic load rating	(N)
P_c	: Calculated load	(N)

*This nominal life formula may not apply if the length of the stroke is less than or equal to twice the length of the nut.

When comparing the nominal life (L_{10}), you must take into account whether the basic dynamic load rating was defined based on 50 km or 100 km. Convert the basic dynamic load rating based on ISO 14728-1 as necessary.

ISO-regulated basic dynamic load rating conversion formula:

$$C_{100} = \frac{C_{50}}{1.26}$$

C_{50}	: Basic dynamic load rating based on a nominal life of 50 km
C_{100}	: Basic dynamic load rating based on a nominal life of 100 km

[Calculating the Modified Nominal Life]

During use, a linear bushing may be subjected to vibrations and shocks as well as fluctuating loads, which are difficult to detect. In addition, the surface hardness of the raceways, the operating temperature, and having blocks arranged directly behind one another will have a decisive impact on the service life. Taking these factors into account, the modified nominal life (L_{10m}) can be calculated according to the following formula (2).

• Modified factor α

$$\alpha = \frac{f_H \cdot f_T \cdot f_c}{f_w}$$

α	: Modified factor	
f_H	: Hardness factor	(see Fig.1 on B4-37)
f_T	: Temperature factor	(see Fig.2 on B4-37)
f_c	: Contact factor	(see Table2 on B4-38)
f_w	: Load factor	(see Table 3 on B4-38)

• Modified nominal life L_{10m}

$$L_{10m} = \left(\alpha \times \frac{C}{P_c} \right)^3 \times 50 \quad \dots\dots(2)$$

L_{10m}	: Modified nominal life	(km)
C	: Basic dynamic load rating	(N)
P_c	: Calculated load	(N)

● **When a Moment Load is Applied to a Single Nut or Two Nuts in Close Contact with Each Other**

When a moment load is applied to a single nut or two nuts in close contact with each other, calculate the equivalent radial load at the time the moment is applied.

$$P_u = K \cdot M$$

P_u : Equivalent radial load (N)
(with a moment applied)

K : Equivalent factors
(see Table4 to Table6 on **A4-41**)

M : Applied moment (N·mm)

However, " P_u " is assumed to be within the basic static load rating (C_0).

● **When a Moment Load and a Radial Load are Simultaneously Applied**

When a moment and a radial load are applied simultaneously, calculate the service life based on the sum of the radial load and the equivalent radial load.

■ **f_H : Hardness Factor**

To maximize the load capacity of the Linear Bushing, the hardness of the raceways needs to be between 58 to 64 HRC.

If the hardness is lower than this range, the basic dynamic load rating and the basic static load rating decrease. Therefore, it is necessary to multiply each rating by the respective hardness factor (f_H).

Normally, $f_H = 1.0$ since the Linear Bushing has sufficient hardness.

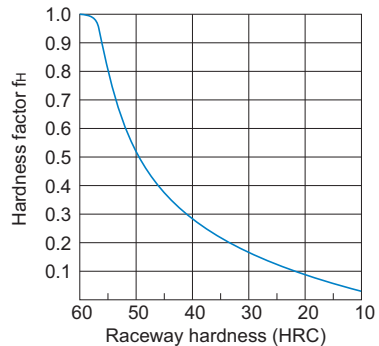

Fig.1 Hardness Factor (f_H)

■ **f_T : Temperature Factor**

If the temperature of the environment surrounding the operating Linear Bushing exceeds 100°C, take into account the adverse effect of the high temperature and multiply the basic load ratings by the temperature factor indicated in Fig.2.

Also note that the Linear Bushing itself must be of high temperature type.

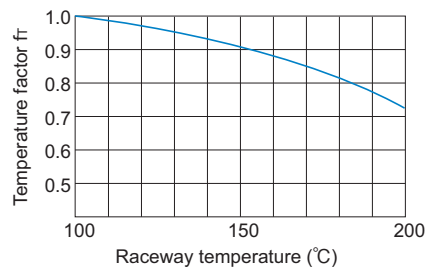

Fig.2 Temperature Factor (f_T)

Note) If the environment temperature exceeds 80°C, use a Linear Bushing type equipped with metal retainer plates.

■ f_c : Contact Factor

When multiple nuts are used in close contact with each other, their linear motion is affected by moments and mounting accuracy, making it difficult to achieve uniform load distribution. In such applications, multiply the basic load rating (C) and (C_0) by the corresponding contact factor in Table2.

Note) If uneven load distribution is expected in a large machine, take into account the respective contact factor indicated in Table2.

Table2 Contact Factor (f_c)

Number of nuts in close contact with each other	Contact factor f_c
2	0.81
3	0.72
4	0.66
5	0.61
Normal use	1

■ f_w : Load Factor

In general, reciprocating machines tend to experience vibrations or impacts during operation, and it is extremely difficult to accurately determine the vibrations generated during high-speed operation and impacts during frequent starts and stops. Therefore, when the actual load applied to a linear bushing cannot be obtained, or when speed and impacts have a significant influence, divide the basic dynamic load rating (C) by the corresponding load factor in Table 3, which has been empirically obtained.

Table 3 Load Factor (f_w)

Vibrations/ impact	Speed(V)	f_w
Faint	Very low $V \leq 0.25\text{m/s}$	1 to 1.2
Weak	Slow $0.25 < V \leq 1\text{m/s}$	1.2 to 1.5
Medium	Medium $1 < V \leq 2\text{m/s}$	1.5 to 2
Strong	High $V > 2\text{m/s}$	2 to 3.5

[Calculating the Service Life Time]

When the nominal life (L_{10}) has been obtained, if the stroke length and the number of reciprocations per minute are constant, the service life time is obtained using the following equation.

$$L_h = \frac{L_{10} \times 10^3}{2 \times \ell_s \times n_1 \times 60}$$

L_h : Service life time (h)

ℓ_s : Stroke length (m)

n_1 : Number of reciprocations per minute (min^{-1})

Precautions To Be Taken if an Eccentric Load Is Applied

Since Linear Bushing is not suitable for application of an eccentric load, we recommend using Guide Ball Bushing or Ball Spline.

Assembling the Linear Bushing

[Inner Diameter of the Housing]

Table1 shows recommended housing inner-diameter tolerance for the Linear Bushing. When fitting the Linear Bushing with the housing, loose fit is normally recommended. If the clearance needs to be smaller, provide transition fit.

Table1 Housing Inner-diameter Tolerance

Type		Housing	
Model No.	Accuracy	Loose fit	Transition fit
LM	High accuracy grade (no symbol)	H7	J7
	Precision Grade (P)	H6	J6
LME	—	H7	K6, J6
LMF	High accuracy grade (no symbol)	H7	J7
LMK			
LMH			
LM-L			
LMF-L			
LMK-L			
LMH-L			
LMIF			
LMIK			
LMIH			
LMIF-L			
LMIK-L			
LMIH-L			
LMCF-L			
LMCK-L			
LMCH-L			

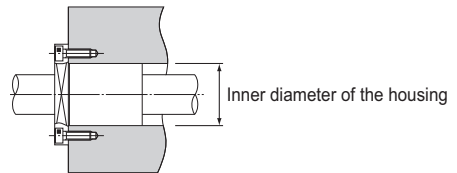

[Clearance between the Nut and the LM Shaft]

When using the Linear Bushing in combination with an LM shaft, use normal clearance in ordinary use and small gap if the clearance is to be minimized.

Note1) If the clearance after installation is to be negative, it is preferable not to exceed the radial clearance tolerance indicated in the specification table.

Note2) The shaft tolerance for Linear Bushing models SC, SL SH and SH-L falls under high accuracy grade (no symbol).

Table2 Shaft Outer-diameter Tolerance

Type		LM Shaft	
Model No.	Accuracy	Normal clearance	Small gap
LM	High accuracy grade (no symbol)	f6, g6	h6
	Precision Grade (P)	f5, g5	h5
LME	—	h7	k6
LMF	High accuracy grade (no symbol)	f6, g6	h6
LMK			
LMH			
LM-L			
LMF-L			
LMK-L			
LMH-L			
LMIF			
LMIK			
LMIH			
LMIF-L			
LMIK-L			
LMIH-L			
LMCF-L			
LMCK-L			
LMCH-L			

[Mounting the Nut]

Although the Linear Bushing does not require a large amount of strength for securing it in the axial direction, do not rely only on a press fit to support the nut. For the housing inner-diameter tolerance, see Table1 on [B4-39](#).

● Mounting a Standard Linear Bushing

Example mountings are shown in Fig. 1 and Fig. 2. Use snap rings or stopper plates to secure linear bushings.

Securing the nut by pressing against the outer surface with one set screw as shown in Fig. 3 will cause the nut to be deformed.

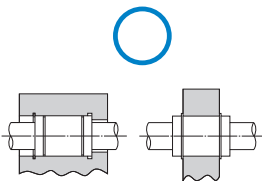

Fig. 1 Secured by snap ring

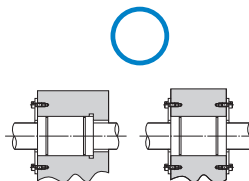

Fig. 2 Secured by stopper plate

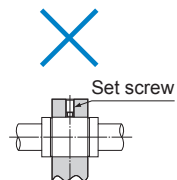

Fig. 3

Mounting Procedure and Maintenance

Assembling the Linear Bushing

■ Snap Ring for Installation

The snap ring types shown in Table 3 can be used for securing the standard Model LM.

Note 1) For models indicated with parentheses, use C-shape concentric snap rings.

Note 2) Table 3 commonly applies to models LM, LM-GA, LM-MG and LM-L.

Table 3 Types of Snap Rings

Model No.	Snap ring			
	For outer surface		For inner surface	
	Needle snap	C-shape snap	Needle snap	C-shape snap
LM 3	—	—	AR 7	—
LM 4	—	—	8	—
LM 5	WR 10	10	10	10
LM 6	12	12	12	12
LM 8	—	15	15	15
LM 8S	—	15	15	15
LM 10	19	19	19	19
LM 12	21	21	21	21
LM 13	23	22	23	—
LM 16	28	—	28	28
LM 20	32	—	32	32
LM 25	40	40	40	40
LM 30	45	45	45	45
LM 35	52	52	52	52
LM 38	—	56•58	57	—
LM 40	—	60	60	60
LM 50	—	80	80	80
LM 60	—	90	90	90
LM 80A	—	120	120	120
LM 100A	—	(150)	150	—
LM 120A	—	(180)	180	—

[Inserting the Nut]

When inserting the standard linear bushing into a housing, do not directly hit the seal or side plate. Use a jig to evenly drive in the nut, or place a flatter piece of metal on the nut and gently hit that. (See Fig. 4)

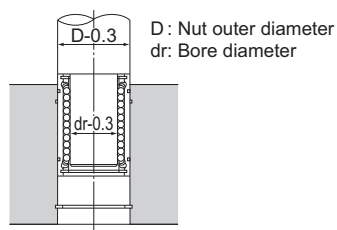

Fig. 4

● Installing a Clearance-adjustable Type

To adjust the clearance of a clearance-adjustable type (-AJ), use a housing that allows adjustment of the nut outer diameter so as to facilitate the adjustment of the clearance between the Linear Bushing and the LM shaft. Positioning the slit of the Linear Bushing at an angle of 90° with the housing's slit will provide uniform deformation in the circumferential direction. (See Fig.5 .)

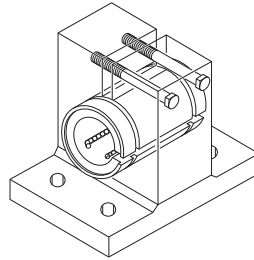

Fig.5

● Mounting an Open Type

For an open type (-OP), also use a housing that allows adjustment of the nut outer diameter as shown in Fig.6 .

Open types are normally used with a light preload. Be sure not to give an excessive preload.

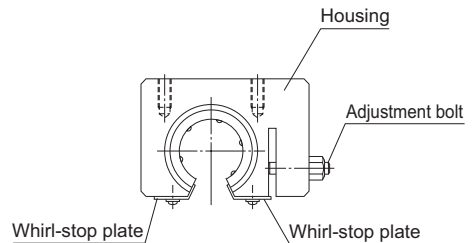

Fig.6

[Precautions on Installing an Open Three-ball-row Type Linear Bushing]

When installing an open three-ball-row type Linear Bushing, mount it while taking into account the load distribution as indicated in Fig.7 .

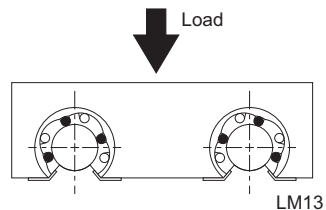

Fig.7

Mounting Procedure and Maintenance

Assembling the Linear Bushing

● Installing the Flanged Type

With models LMF, LMK, LMH, LMIF, LMCF, LMIK, LMCK, LMIH, and LMCH, the nut is integrated with a flange. Therefore, the linear bushing can be mounted only via the flange.

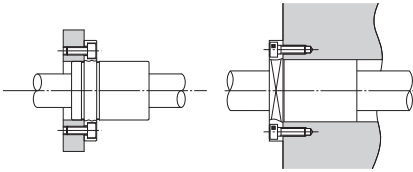

Mounted via spigot and socket joint

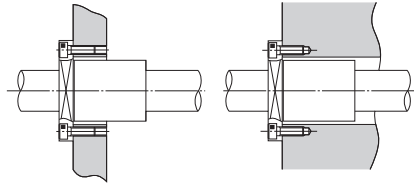

Mounted via flange only

However, the Model LMJK must be mounted via a spigot and socket joint. Please do not mount using just the flange.

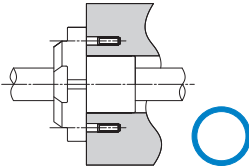

Mounted via spigot and socket joint

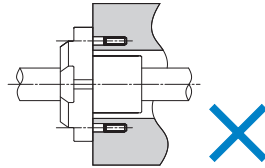

Mounted via flange only

[Installing the LM Case Unit]

● Attaching Model SC (SL)

Models SC and SL can be affixed from either above or below using bolts. (See Fig. 8)

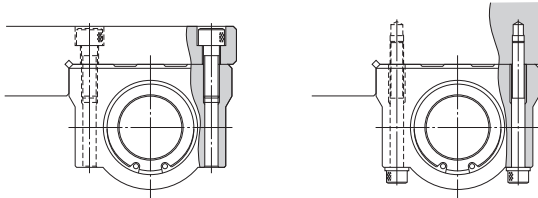
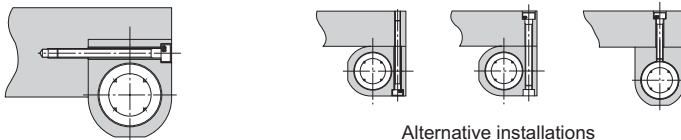

Fig. 8

● Attaching the Model SH (SH-L)

Models SH and SH-L can be affixed in any direction using bolts. (See Fig. 9)



Basic installation

Alternative installations

Fig. 9

[Mounting the Shaft End Support]

Shaft end support model SK can easily be secured to the table using mounting bolts. Model SK enables the LM shaft to firmly be secured using tightening bolts.

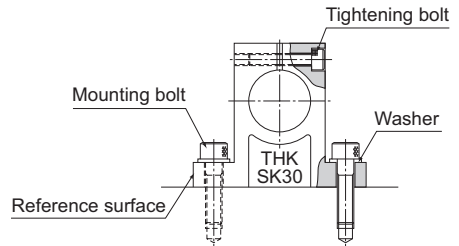

[Inserting the LM Shaft]

When inserting the LM shaft into the Linear Bushing, align the center of the shaft with that of the nut and gently insert the shaft straightforward into the nut. If the shaft is slanted while it is inserted, balls may fall off or the retainer may be deformed. (See Fig.10 .)

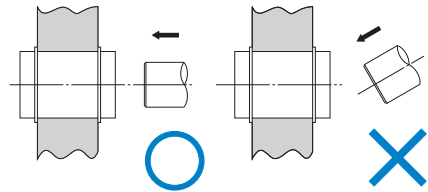

Fig.10

[When Under a Moment Load]

When using the Linear Bushing, make sure the load is evenly distributed on the whole ball raceway. In particular, if a moment load is applied, use two or more Linear Bushing units on the same LM shaft and secure an adequately large distance between the units.

If using the Linear Bushing under a moment load, also calculate the equivalent radial load and identify the correct model number. (See [B4-37](#) .)

Mounting Procedure and Maintenance

Assembling the Linear Bushing

[Rotational Use Not Allowed]

The Linear Bushing is not suitable for rotational use for a structural reason. (See Fig.11 .)

Forcibly rotating it may cause an unexpected accident.

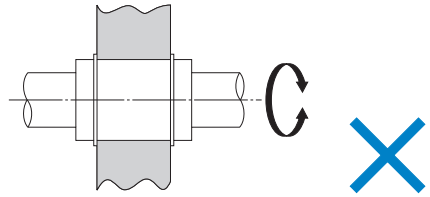

Fig.11

[Attaching Felt Seal Model FLM]

The felt seal can be press-fit into a housing finished to H7, but cannot be used as a stopper for preventing the Linear Bushing from coming off. Be sure to use the felt seal by attaching it as indicated in the Fig.12 .

Also make sure to impregnate the felt with sufficient lubricant before attaching it.

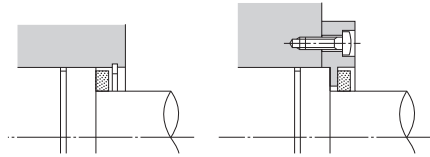

Fig.12

Lubrication

The Linear Bushing requires grease or oil as a lubricant for its operation.

[Grease Lubrication]

Before mounting the product onto the LM shaft, apply grease to each row of balls inside the Guide Ball Bushing.

Thereafter apply grease as necessary, in accordance with usage and other conditions noted above, or attach housing as shown in Fig. 1, or apply grease directly to the LM shaft.

We recommend using lithium soap-based grease No. 2.

[Oil Lubrication]

Apply the required amount of oil or grease-based lubricant onto the LM shaft and set it in the housing as shown in Fig. 1.

Commonly used lubricants include turbine oil, machine oil, and spindle oil.

In addition to the procedures described the above, an oil hole or grease nipple can also be used for lubrication. For further information, contact THK.

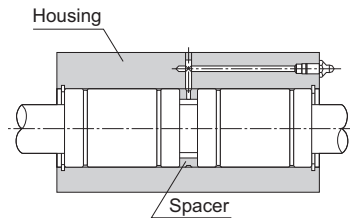

Fig. 1

Material and Surface Treatment

For the Linear Bushing and the LM shaft, highly corrosion-resistant stainless steel types are available for some models.

Although the LM shaft can be surface treated, some types may not be suitable for the treatment. Contact THK for details.

Dust prevention

Entrance of dust or other foreign material into the Linear Bushing will cause abnormal wear or shorten the service life. When entrance of dust or other foreign material is a possibility, it is important to select effective seals and/or a dust-control device that meets the service environment conditions.

For the Linear Bushing, a special synthetic rubber seal that is highly resistant to wear and a felt seal (highly dust preventive with low seal resistance) are available as contamination protection accessories.

In addition, THK produces round bellows. Contact us for details.

Felt Seal Model FLM

● For detailed dimensions, see [B4-120](#).

Linear Bushing model LM series include types equipped with a special synthetic rubber seal (LM···UU, U). If desiring to have an additional contamination protection measure, or desiring to lower the seal resistance, use the felt seal model FLM.

Model Number Coding

Model number configurations differ depending on the model features. Refer to the corresponding sample model number configuration.

[Linear Bushing]

- LM, LME, LM-L, LMF, LMF-L, LMK, LMK-L, LMJK, LMJK-L, LMH, LMH-L, LMIF, LMIF-L, LMCF-L, LMIK, LMIK-L, LMCK-L, LMIH, LMIH-L, LMCH-L, SC, SL, SH, SH-L

LM20 **L** **UU**
 Model No. | With nut seal
 Long type

- LM-M, LM-MG, LMF-M, LMF-ML, LMK-M, LMK-ML, LMH-M, LMH-ML

LMF20 **M** **L** **UU**
 Model No. | | With nut seal
 Made of stainless steel Long type

- LM-GA, LM-MGA, LME-GA

LM20 **M** **GA** **UU**
 Model No. | | With nut seal
 Made of stainless steel Metal retainer specification

■Notes on Ordering

For high temperature applications, seals (symbol: UU) can be attached to both ends of the nut on linear bushes used with metal cages (symbol: A). However, cages without seals are recommended, since the seals are only heat-resistant to a temperature of 80°C.

Model No.

[LM Shaft End Support]

● Model SK

SK20

Model No.

[LM Shaft]

● Model SF

SF25	g6	-500L	K
Model No.	LM shaft outer diameter tolerance	Overall LM shaft length (in mm)	Special symbol* no symbol: solid shaft K: standard hollow shaft M: special material F: with surface treatment

*If two or more symbols are given, they are shown in an alphabetical order.

*For information shaft diameters, permissible shaft diameter error and standard stock lengths, see **A4-109**.

[Felt Seal]

● Model FLM

FLM 20

Model No.

Precautions on Use

Linear Bushing

[Handling]

- (1) Disassembling each part may cause dust to enter the system or degrade mounting accuracy of parts. Do not disassemble the product.
- (2) Take care not to drop or strike the Linear Bushing. Doing so may cause injury or damage. Giving an impact to it could also cause damage to its function even if the product looks intact.
- (3) When handling the product, wear protective gloves, safety shoes, etc., as necessary to ensure safety.

[Precautions on Use]

- (1) Prevent foreign material, such as cutting chips or coolant, from entering the product. Failure to do so may cause damage.
- (2) If the product is used in an environment where cutting chips, coolant, corrosive solvents, water, etc., may enter the product, use bellows, covers, etc., to prevent them from entering the product.
- (3) Do not use the product at temperature of 80°C or higher. Exposure to higher temperatures may cause the resin/rubber parts to deform/be damaged.
- (4) If foreign material such as cutting chips adheres to the product, replenish the lubricant after cleaning the product.
- (5) Micro-strokes tend to obstruct oil film to form on the raceway in contact with the rolling element, and may lead to fretting corrosion. Take consideration using grease offering excellent fretting prevention. It is also recommended that a stroke movement corresponding to the length of the outer cylinder be made on a regular basis to make sure oil film is formed between the raceway and rolling element.
- (6) Do not use undue force when fitting parts (pin, key, etc.) to the product. This may generate permanent deformation on the raceway, leading to loss of functionality.
- (7) Insert the shaft straight through the opening. Inserting the shaft at an angle can introduce foreign matter, damage internal components, or cause balls to fall out.
- (8) Using this product with any balls removed may result in premature damage.
- (9) Please contact THK if any balls fall out; do not use the product if any balls are missing.
- (10) If an attached component is insufficiently rigid or mounted incorrectly, the bearing load will be concentrated at one location and performance will decline significantly. Make sure the housing and base are sufficiently rigid, the anchoring bolts are strong enough, and the component is mounted correctly.

[Lubrication]

- (1) Thoroughly wipe off anti-rust oil and feed lubricant before using the product.
- (2) Do not mix different lubricants. Mixing greases using the same type of thickening agent may still cause adverse interaction between the two greases if they use different additives, etc.
- (3) When using the product in locations exposed to constant vibrations or in special environments such as clean rooms, vacuum and low/high temperature, use the grease appropriate for the specification/environment.
- (4) To lubricate the product, apply lubricant directly to the raceway surface and execute a few preliminary strokes to ensure that the interior is fully lubricated.
- (5) The consistency of grease changes according to the temperature. Take note that the slide resistance of the Linear Bushing also changes as the consistency of grease changes.

Precautions on Use

- (6) After lubrication, the slide resistance of the Linear Bushing may increase due to the agitation resistance of grease. Be sure to perform a break-in to let the grease spread fully, before operating the machine.
- (7) Excess grease may scatter immediately after lubrication, so wipe off scattered grease as necessary.
- (8) The properties of grease deteriorate and its lubrication performance drops over time, so grease must be checked and added properly according to the use frequency of the machine.
- (9) The greasing interval varies depending on the use condition and service environment. Set the final lubrication interval/amount based on the actual machine.

[Storage]

When storing the Linear Bushing, enclose it in a package designated by THK and store it in a room while avoiding high temperature, low temperature and high humidity.

[Disposal]

Dispose of the product properly as industrial waste.

