

S5

Rodless cylinders with integrated slide - Ø 25÷50 mm Technopolymer sliding guide

- Extruded aluminium profile Ø 25÷50 mm
- Stroke length up to 6m
- Flexible guiding system
- Sliding of carriage by means of plastic slides on steel rods
- Translation speed 0,2÷1,5 m/sec
- Version with locking unit available upon request

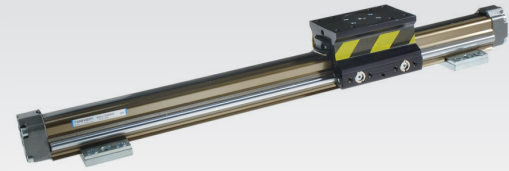

TECNICAL CHARACTERISTICS

Ambient temperature	-20÷80 °C
Fluid	filtered air, with or without lubrication
Working pressure	3÷10 bar
Bores	Ø 25 - 32 - 40 - 50 mm
Cushionings	adjustable on both sides

CONSTRUCTIVE CHARACTERISTICS

End-cap	die-cast aluminium
Barrel	anodized aluminium
Piston	aluminium
Guide slide	acetalic resin
Piston seal	double lip nitrile rubber (NBR)
Shock absorber seals	nitrile rubber (NBR) on both sides

CODIFICATION KEY

S	5	0	1	1	2	5	0	8	5	0	
1	2	3	4	5	6						

1 Series S5 = Ø 25÷50 mm - Rodless cylinders with integrated guides Technopolymer sliding guide	2 Carriage type 0 = Standard carriage (except Ø 40 - 50 mm) 2 = Medium carriage 3 = Long carriage	3 Left end-cap supply port 0 = No supply port (both chambers are supplied from the right end-cap) 1 = Side supply port 2 = Bottom supply port 3 = Rear supply port
4 Right end-cap supply port 1 = Side supply port 2 = Bottom supply port 3 = Rear supply port 4 = Rear supply ports for both chambers on the right end-cap	5 Bore (mm) 25 = Ø25 32 = Ø32 40 = Ø40 50 = Ø50	6 Stroke (mm) Up to 6000

Technopolymer sliding guide

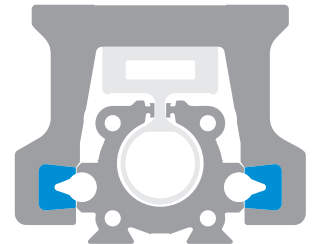

S5 with L6 locking unit



Stroke tolerances

Ø	mm
25	+2,5 - 0
32	+3,2 - 0
40	+3,2 - 0
50	+3,2 - 0

Cylinder mass
Standard carriage

Cylinder mass
Medium carriage

Cylinder mass
Long carriage

Ø	Cylinder - stroke 0		Increase for 100 mm stroke		Cylinder - stroke 0		Cylinder - stroke 0	
	g		g		g		g	
25	1625		365		1930		264	
32	2775		495		3265		465	
40	-		920		6095		860	
50	-		1280		10030		14040	

Theoretical forces (N) at different working pressure (bar)

Static load value (N) and torque (Nm)

Please note that in dynamic conditions, the load must be reduced due to effects associated with the speed.

A moment is the product of the load (Newton) and the arm (meters), i.e the distance between the centre of gravity of the load and the longitudinal axis of the piston.

1

Force 6 bar	Load			Bending moment	Torque	Bending moment							
	P1	P2	P3	M1	M2	M3							
Ø	Force F (N)	Load			Standard carriage			Medium carriage			Long carriage		
		P1 (N)	P2 (N)	P3 (N)	M1 (Nm)	M2 (Nm)	M3 (Nm)	M1 (Nm)	M2 (Nm)	M3 (Nm)	M1 (Nm)	M2 (Nm)	M3 (Nm)
25	250		400		13	8	16	20	10	25	40	15	50
32	420		400		20	9	27	30	12	40	55	18	75
40	640		600		-	-	-	60	30	80	110	45	150
50	1050		800		-	-	-	85	50	110	150	75	210

Fixing elements and accessories

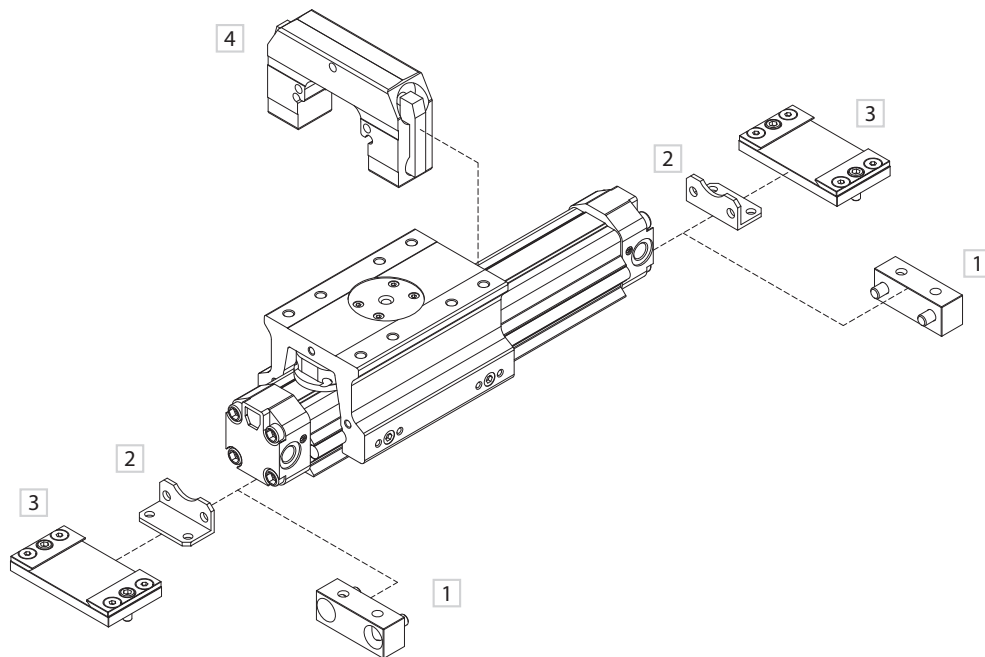

DESCRIPTION	NOTE	PART NO.
1 Bracket Ø40-50	Anodized aluminium	SF-13 ___
2 Angle bracket Ø25-32	Zinc-plated steel	SF-13 ___
3 Fixing plate	Zinc-plated steel	SF-12 ___
4 L6 locking unit	-	L6-S5 ___

Rodless cylinders with integrated guides and standard carriage - 8 fixing holes

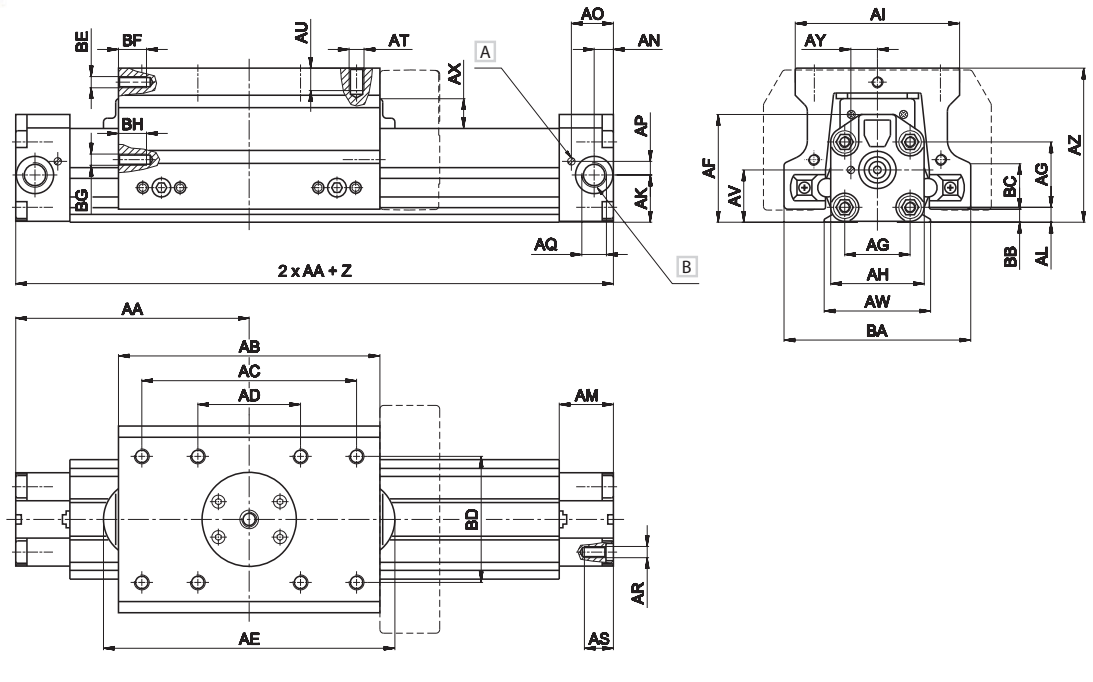
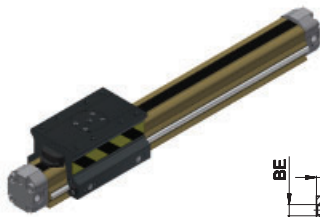

1

Z = Stroke

Ø	AA	AB	AC	AD	AE	AF	AG	AH	AI	AK	AL	AM	AN	AO	AP	AQ	AR
25	100	106	90	50	130	48,3	28	40,5	70	20,2	7	24	7,4	18,2	5,7	G1/8	M5
32	125	140	115	55	156	57	35	50	88	25,3	8	29	10,3	22,5	7,3	G1/4	M6
40	-	-	-	-	-	-	44	64	90	33,8	11,8	33	12,5	26,5	8,7	G3/8	M8
50	-	-	-	-	-	-	55	80	100	41,4	14,7	33	14,2	25,7	11,8	G3/8	M10

Ø	AS	AT	AU	AV	AW	AX	AY	AZ	BA	BB	BC	BD	BE	BF	BG	BH
25	12	M6	10	22,8	42,8	16	12,2	71,8	85	5,7	24	50	15	M6	M6	15
32	15,5	M6	12	28	57	16	14,2	82,5	100	7	24,5	67,5	15	M6	M6	15
40	20	M8	14	37	67	19,5	16,5	106,6	135	7	39	65	15	M6	M6	15
50	20	M8	16	47,7	86	20,5	19,1	123,7	149	7,2	41	76,5	16	M8	M6	15

Dimensions of the L6 locking unit are indicated by dotted lines; for the fixing holes of the locking unit, see dedicated chapter.

For Ø 40 - 50 the standard carriage is not available

A Pneumatic cushioning adjusting screw

B Side supply port

Rodless cylinder with integrated guides and medium carriage - 8 fixing holes

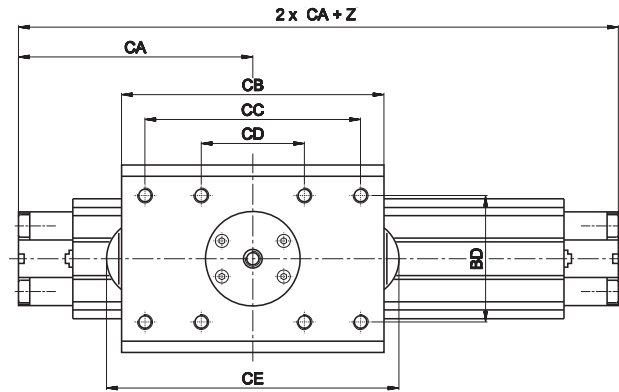
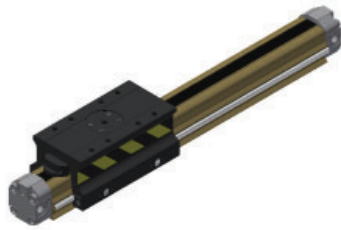

Rodless cylinder with integrated guides and long carriage - 12 fixing holes

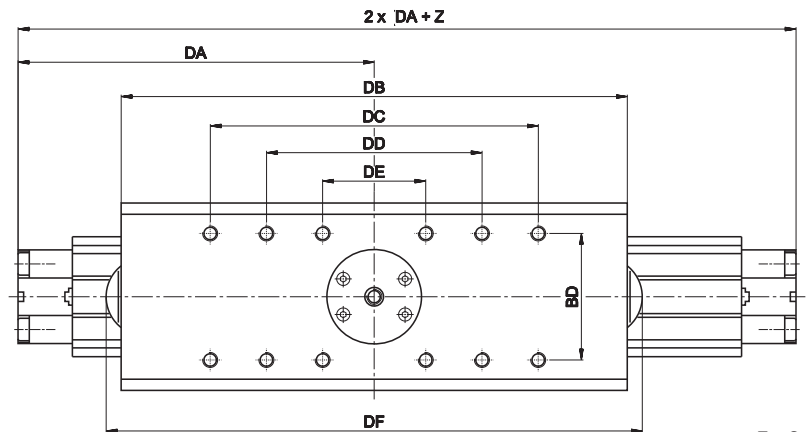
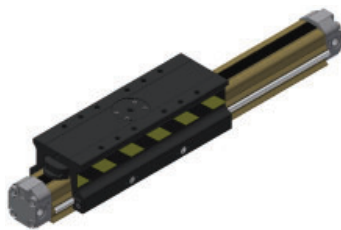

Z = Stroke

Ø	BD	CA	CB	CC	CD	CE	DA	DB	DC	DD	DE	DF
25	50	114,5	136	90	50	160	147,5	201	130	90	50	225
32	67,5	142,5	175	115	55	191	190	270	175	115	55	286
40	65	169	205	180	75	215	225	317	280	185	75	327
50	76,5	205	258	190	80	271	277	398	320	200	80	411

Fixing plate

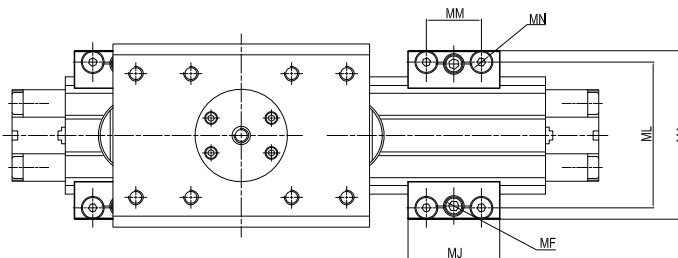
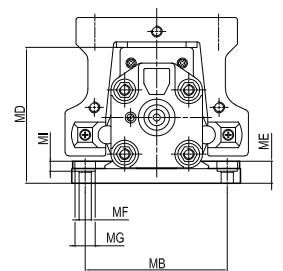
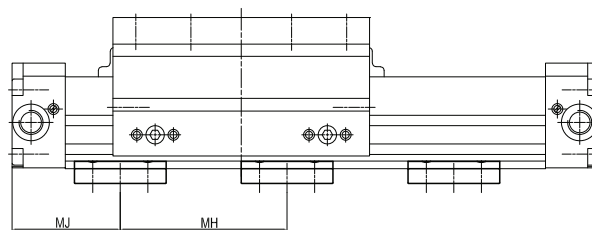
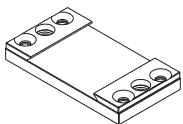

Material: Zinc-plated steel

Cylinder Ø	MA	MB	MC	MD	ME	MF	MG	MH	MI	MJ	ML ^(b)	MM	MN	Mass g	Part no.
25	78,5	63,5	50	79,8	12	M8	11	500 (a)	6,5	55	65,5	30	M6	310	SF-12025
32	92	77,5	50	90,5	12	M8	11	600 (a)	8,5	60	79,5	30	M6	340	SF-12032
40	117	96	60	116,6	15	M10	14	700 (a)	8	70	96	37,5	M8	660	SF-12040
50	136	115	60	133,7	15	M10	14	800 (a)	8	70	115	37,5	M8	700	SF-12050

(a) = Max allowable dimension to limit the bending of cylinder according to the stroke and to provide a correct fixing

(b) = For Ø 40 - 50 mm, MB and ML dimensions are the same

Angle bracket

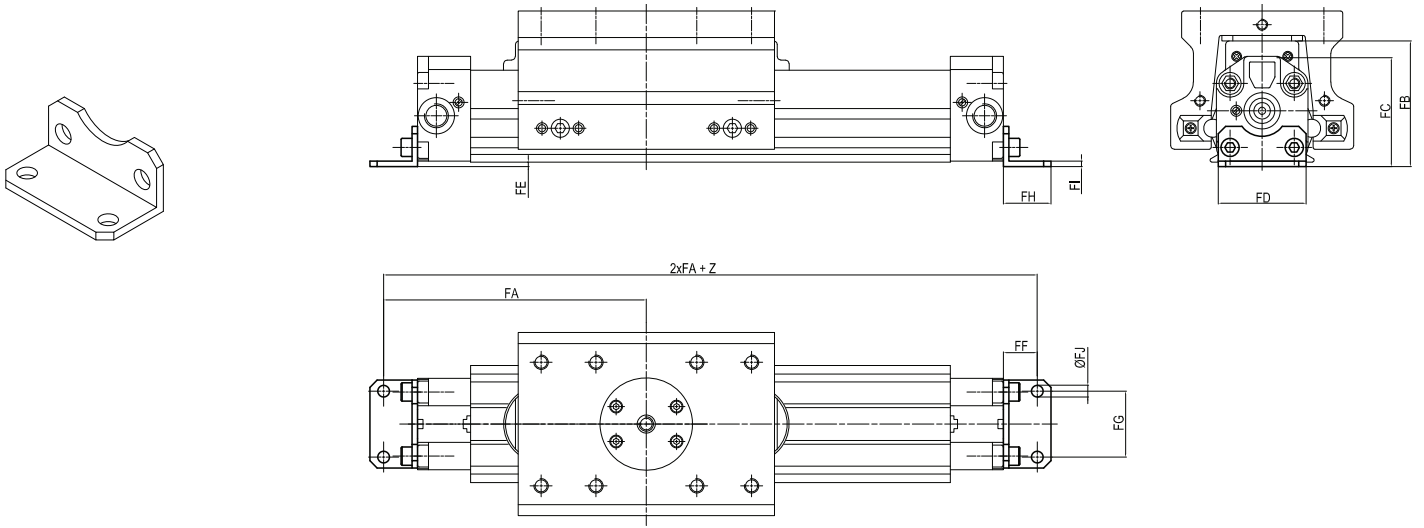

Material: Zinc-plated steel

Cylinder Ø	FA	FB	FC	FD	FE	FF	FG	FH	FI	FJ	Mass g	Part no.
25	116	58,1	48,8	40	0,5	16	27	22	2,5	5,5	34	SF-13025
32	143,5	68,7	59,2	48	2,5	18,5	36	26	3	6,5	53	SF-13032

1

Bracket

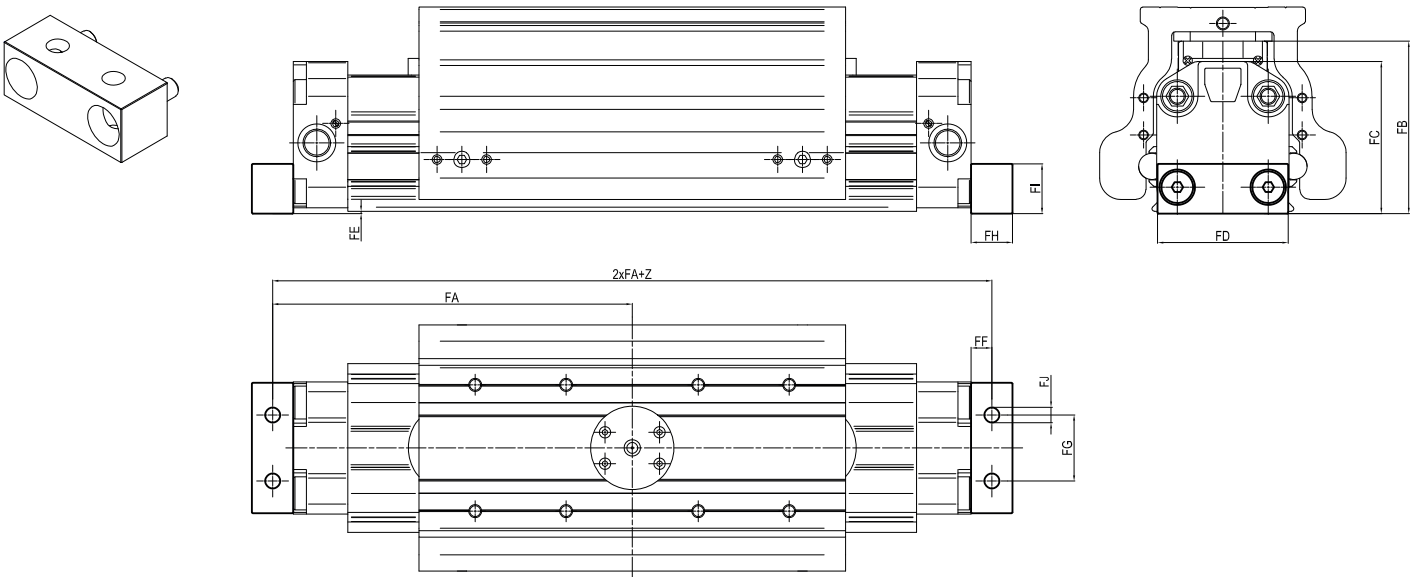

Material: Anodized aluminium

Cylinder Ø	FA	FB	FC	FD	FE	FF	FG	FH	FI	FJ	Mass g	Part no.
40	162,5	86,5	74,9	63	0,7	12,5	30	25	25	9	116	SF-13040
50	187,5	104,3	92,4	79	1,3	12,5	40	25	30	9,3	170	SF-13050

EXAMINATION AND VERIFICATION OF THE CUSHIONING

In a system with moving masses, as in the case of rodless cylinders, it is essential to control the dissipation of the system's kinetic energy as it is brought to a stop. First of all, it is necessary to establish and verify the most suitable method for cushioning the system, in order to avoid the moving mass (carriage with load) striking against the end-caps and compromising the life of the cylinder.

If the point corresponding to a given load and speed lies beneath the appropriate curve, the cushioning is able to absorb the kinetic energy of the system.

Vice versa if the point lies above the curve, the cushioning is not able to absorb the kinetic energy. In that case you must:

- decrease the load and maintain the translation speed
- decrease the speed and maintain the load
- select a cylinder with a bigger bore or with twin chambers

The cushioning capacity is shown in the diagram below, referenced to the final speed as the carriage approaches the end-caps for S1- S5 - VL1 series

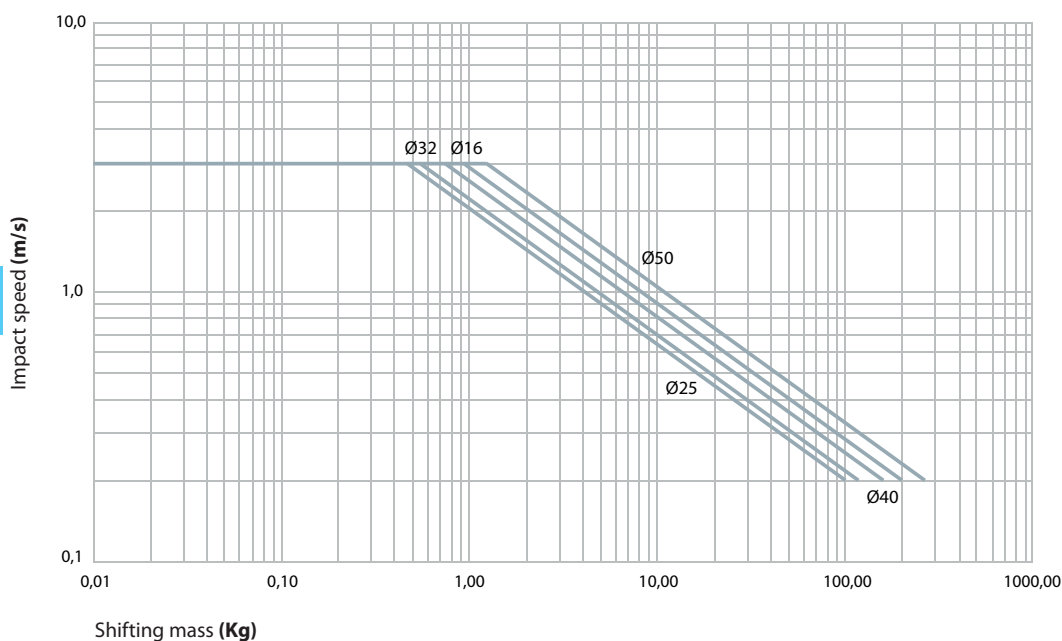

As a result, if cushionings can not absorb the kinetic energy and changing the working parameters is not possible, it is necessary to provide an additional hydraulic shock absorber (YDA / YDR series) to reduce the load speed before the cushionings operate.

DYNAMIC LOAD CAPACITY

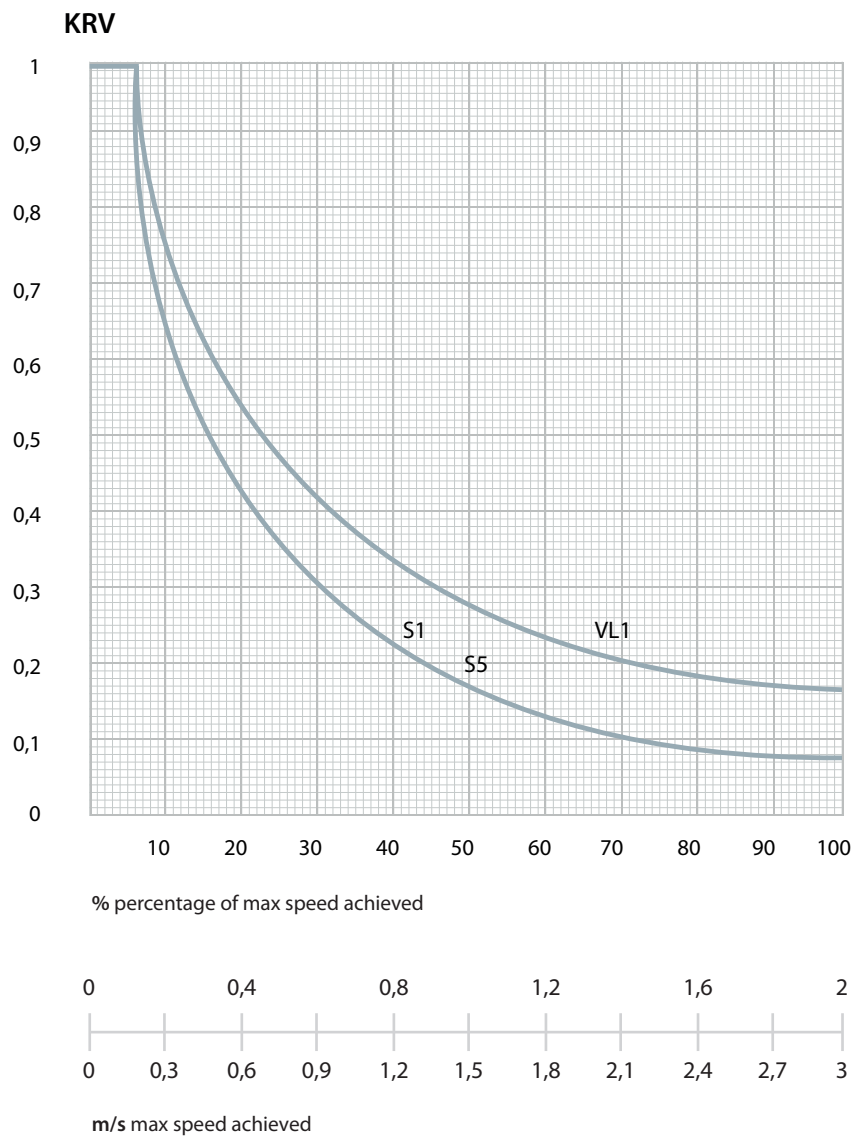

1) Calculation of the operational speed percentage in relation to the max allowable speed:

$$\% = \frac{\text{Operational speed (m/s)}}{\text{Max. allowable speed (m/s)}} \cdot 100$$

2) Apply the following formula for the calculation of the max. dynamic load:

$$CD = CM \cdot KRV$$

CD = Max. dynamic load (N)

CM = Max. static load (N). See relevant load tables for the various series

KRV = System coefficient (which acts to reduce the max. load based on the system speed)

CYLINDER SELECTION

As previously discussed, it is necessary to produce (for a correct use of the cylinder) a gradual deceleration of the moving mass.

CYLINDER WITH LOAD MOUNTED DIRECTLY ON THE CARRIAGE (picture A)

Let us consider the case of a S1 series cylinder with a load of 50 N placed on the carriage, at the max. translation speed of 1,2 m/s., as shown in the picture. Verify the cushioning capacity and calculate the capacity of the dynamic load and of the torque and bending moments.

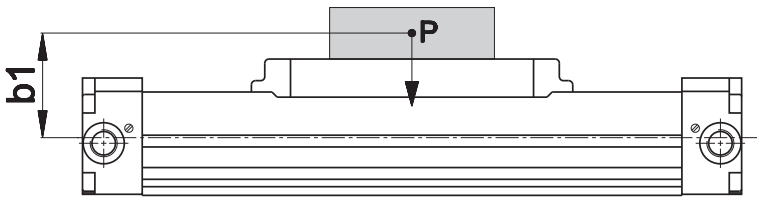

$$\begin{aligned} P &= 50 \text{ N} \\ V &= 1,2 \text{ m/s.} \\ b1 &= 110 \text{ mm} \end{aligned}$$

VERIFICATION OF THE CUSHIONING CAPACITY

According to the graph shown on page 22 a 50 bore size cylinder is able to absorb the developed kinetic energy developed by the application in the picture above, since the intersection point corresponding to the speed and load lies beneath the cushioning curve.

1

VERIFICATION AND CALCULATION OF THE DYNAMIC LOAD CAPACITY

Using the equation 1, we can calculate the percentage between the operation speed and allowable speed.

$$\% = \frac{\text{Operation speed (m/s)}}{\text{Allowable speed (m/s)}} \cdot 100 = \frac{1,2 \text{ m/s.}}{3 \text{ m/s.}} \cdot 100 = 40\%$$

From the graph given on page 23 we can determine the KRV (coefficient of speed reduction)

$$\text{KRV} = 0,24$$

Applying the equation 2 on page 23 we can determine the max. permitted dynamic load.

$$\text{CD} = \text{CM} \cdot \text{KRV}$$

CD = Dynamic load

CM = Static load 500 N (see table for S1 50mm cylinder series - P1 page 3)

$$\text{CD} = 500 \cdot 0,24 = 120 \text{ N}$$

As $P (50 \text{ N}) < CD (120 \text{ N})$ the S1 series 50 bore cylinder is suitable for the application

CARRIAGE STRESSES

Different load applications have different moments M1 - M2 - M3, which directly influence the life of the cylinder. By selecting a cylinder that can support off-set loads, we can avoid compromising the cylinder life. Load must be applied, if possible, so that it acts through the centre point B (see picture).

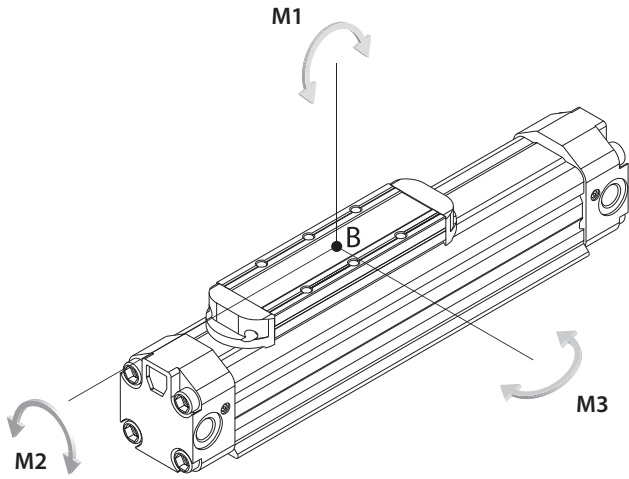

CALCULATION OF THE TORQUE M1 - M2 - M3

In order to calculate the various moments, which act on the carriage, we must calculate the force, generated by the load, when it is subjected to accelerations and decelerations.

$$a = \frac{V^2}{2L \cdot 10^{-3}} = (\text{m/sec.}^2)$$

a = Acceleration/deceleration
 V = Speed in m/s.
 L = Cushion length in mm

CUSHION LENGTH

∅	L
	mm
16	16,5
25	25
32	32,5
40	41,5
50	52

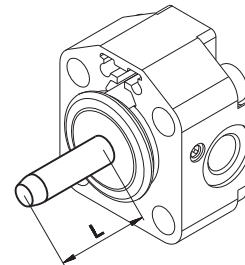

$$a = \frac{1,2^2}{2 \cdot 52 \cdot 10^{-3}} = 13,8 (\text{m/sec.}^2)$$

$$F = m \cdot a$$

F = Force m = Mass (P/9,81)

$$F = \frac{50}{9,81} \cdot 13,8 = 70 \text{ N}$$

$$M1 = F \cdot b1$$

The example A on page 24 is subjected to the moment M1 as the load decelerates through the cushion.

M1 = Torque

b1 = Distance between the centre of gravity of load P and the centre of gravity through the cylinder centre line (see picture A on page 24)

$$M1 = 70 \cdot 110 = 7700 \text{ Nmm} = 7,7 \text{ Nm}$$

The equation gives the following result:

$$M1 = 7,7 \text{ Nm} < 19 \text{ Nm} \text{ (see table for S1 50mm cylinder series - M1 page 3)}$$

Thus S1 series, bore size 50, with standard carriage is suitable for the movement of the load in the given conditions. If the calculated value is equal to or higher than the value given in the table, it is necessary to select a different size of carriage, or a different type of rodless cylinder (e.g with integrated slide)

1

ATTENTION!

If the translation speed of example A is 2 m/s instead of 1,2 m/s, the cushioning capacity of the cylinder, given in the example, will not be enough to absorb the kinetic energy generated by the moving load.

Therefore it is necessary to reduce the translation speed before reaching the cushion, by means of shock absorbers until the value is 1,2 m/s (for example).

SIZING OF A POSSIBLE HYDRAULIC SHOCK ABSORBER

The hydraulic shock absorber must be mounted, so as to strike the centre of gravity of the load.

$$E_c = \frac{1}{2} \cdot m \cdot V^2$$

E_c = Kinetic energy

m = Mass ($P/9,81$)

V = Translation speed (2 m/s)

P = Weight 50 N

$9,81$ = Acceleration of the centre of gravity

$$E_c = \frac{1}{2} \cdot \frac{50}{9,81} \cdot 2^2 = \frac{200}{19,62} = 10 \text{ Nm}$$

In this case the hydraulic shock absorber must have a capacity greater than or equal to 10 Nm.

CYLINDER WITH MISALIGNED LOAD (picture B)

Let us suppose that we want to move a load of 50 N displaced at a distance B3 from the central axis, at a maximum translation speed of 1,2 m/s. Due to the misaligned load a cylinder with an external carriage is required and we must verify if a S5 cylinder with integrated slide is suitable for this application.

$P_3 = 50 \text{ N}$
 $V = 1,2 \text{ m/s}$
 $b_2 = 150 \text{ mm}$
 $b_3 = 200 \text{ mm}$

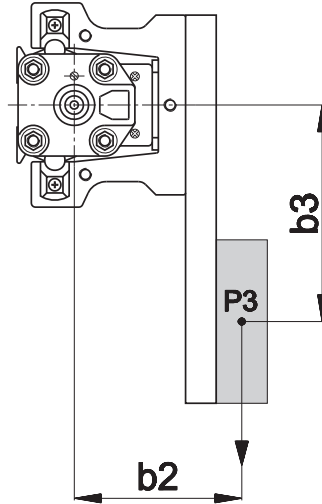

VERIFICATION OF THE CUSHIONING CAPACITY

The S5 series cylinder (graph on page 22), 40 mm bore, can absorb the kinetic energy developed by the 50 N load at a speed of 1,2 m/s.

VERIFICATION AND CALCULATION OF THE CARRIAGE MOMENTS

Using the equation we can calculate the percentage of the max. speed as follows.

$$\% = \frac{\text{Operational speed (m/s)}}{\text{Allowable speed (m/s)}} \cdot 100 = \frac{1,2 \text{ m/s}}{3 \text{ m/s}} \cdot 100 = 40\%$$

From the graph given on page 23 we can determine the KRV coefficient.

$$\text{KRV} = 0,24$$

Applying the equation 2 on page 23 we can determine the max. allowable dynamic load.

$$\text{CD} = \text{CM} \cdot \text{KRV}$$

$\text{CD} =$ Dynamic load
 $\text{CM} =$ Static load 600 N (see table for S5 50mm cylinder series - P3 page 12)

$$\text{CD} = 600 \cdot 0,24 = 144 \text{ N}$$

As $P_3 (50 \text{ N}) < \text{CD} (144 \text{ N})$ the S5 series 40 bore cylinder is suitable for the application.

CALCULATION AND VERIFICATION OF THE CARRIAGE MOMENTS

As load P is misaligned (B3) from the central axis of the cylinder, the carriage is acted on by a significant moment M3, so that it is necessary to use a cylinder with an external carriage.

CALCULATION OF THE MOMENTS M1 - M2 - M3 AND CARRIAGE SELECTION

$$a = \frac{V^2}{2L \cdot 10^{-3}} = (\text{m/sec.}^2)$$

a = Acceleration/deceleration

m = Mass (P/9,81)

F = Force

P = Weight in N

9,81 = Centre of gravity acceleration

L = Length in mm of the internal cushion (see on page 25)

V = Speed in m/s

$$a = \frac{1,2^2}{2 \cdot 41,5 \cdot 10^{-3}} = 17,3 (\text{m/sec.}^2)$$

$$F = m \cdot a = \frac{P}{9,81} \cdot 17,3 = \frac{50}{9,81} \cdot 17,3 = 88 \text{ N}$$

1

The example is subjected to moments M1 - M2 - M3

$$M1 = F \cdot b2 = 88 \cdot 150 = 13200 \text{ Nmm} = 13,2 \text{ Nm} \quad (M1 \text{ max } 60 \text{ Nm})$$

$$M2 = P \cdot b2 = 50 \cdot 150 = 7500 \text{ Nmm} = 7,5 \text{ Nm} \quad (M2 \text{ max } 30 \text{ Nm})$$

$$M3 = F \cdot b3 = 88 \cdot 200 = 17600 \text{ Nmm} = 17,6 \text{ Nm} \quad (M3 \text{ max } 80 \text{ Nm})$$

By comparing the calculated values to the max values on page 12, it can be deduced that the medium carriage is suitable for this application.

CYLINDER WITH MISALIGNED LOAD IN VERTICAL POSITION

In this instance let us suppose to verify if a 40 mm bore VL1 series cylinder, in the vertical plane, is sufficient to move a 50 N load misaligned at a distance b3, at a speed of 1,2 m/s.

P = 50 N

V = 1,2 m/s

b1 = 110 mm (see picture A)

b3 = 200 mm

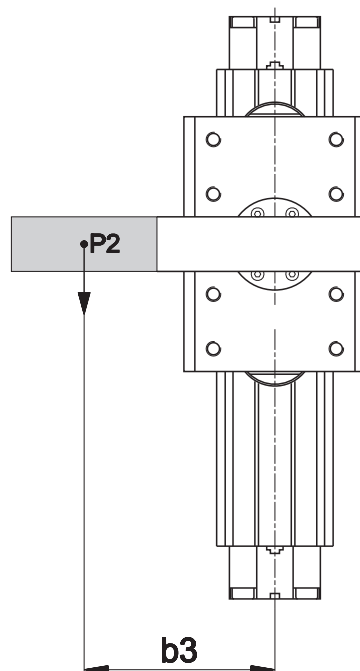

ATTENTION!

If the cylinder is vertically mounted, the cushioning capacity is reduced by 40%.

By checking the data given in the example, we note that the cylinder, in the vertical position, is not able to cushion the load and it is therefore necessary to use a 50 mm bore cylinder or an external shock absorber (see on page 26). Now we must calculate the dynamic load capacity and the developed moments. To obtain the value of the KRV coefficient follow the procedure as given in the examples, which will result in a coefficient of KRV 0,24 (see pictures A and B).

$$CD = CM \cdot KRV = 1100 \cdot 0,24 = 264 \text{ N}$$

$$P < CD$$

The cylinder is therefore able to move the applied load.

In this application the moment M2 is not generated, as no force is acting transversally to the moving axis; therefore we must calculate only the moments M1 and M3.

$$F = m \cdot a$$

$$a = \frac{V^2}{2L \cdot 10^{-3}} = 17,3 \text{ (m/sec.}^2\text{)} \quad \text{(picture B)}$$

$$F = m \cdot a = 88 \text{ N} \quad \text{(picture B)}$$

$$M1 = F \cdot b1 = 88 \cdot 110 = 9680 \text{ Nmm} = 9,68 \text{ Nm} \quad \text{(M1 max 120 Nm)}$$

$$M3 = F \cdot b3 = 88 \cdot 200 = 17600 \text{ Nmm} = 17,6 \text{ Nm} \quad \text{(M3 max 120 Nm)}$$

By comparing the obtained values with the maximum values in table at page 18, we can verify that the cylinder is proper, but in order to cushion the vertical load, we must either use an external cushion, increase the cylinder bore size or use another cylinder series.

FOR A CORRECT USE SEE THE FOLLOWING INSTRUCTIONS:

1. For a longer life of the cylinder it is suggested to use the cylinder at a speed of 1 m/s
2. If the cushioning value is in proximity to the max. value, please apply an additional shock absorber
3. If the cylinder is used vertically, the cushioning capacity is reduced by 40%.
4. Maintain a correct and constant lubrication.