



HENNLICH

MERES

# PÁDLOVÝ HLÍDAČ PRŮTOKU F10/F50

## DESCRIPTION

Magnetrol flow switches are highly reliable devices utilized to sense the start or stop of flow in horizontal pipelines containing oil and petroleum derivatives, chemicals, water, or air.

Vane actuated model F10 switches are used on gas or liquid flow applications in 2" or larger pipe sizes.

Disc actuated model F50 switches are in-line type used for sensing clean liquids in 2" or smaller pipe sizes.

## FEATURES

- Actuation on increasing or decreasing flow
- Special sensing elements for non-standard or high flow applications
- Designed for horizontal pipe applications
- Standard anti corrosive protection

### Model F10:

- Field adjustable
- Low pressure drop
- Process temperature up to +230 °C (+450 °F)
- Process pressure up to 69 bar (1000 psi)
- Standard flow vanes for 2" thru 10" flow lines

### Model F50:

- No calibration required
- Bronze or stainless steel construction
- Process temperature up to +400 °C (+750 °F)
- Process pressure up to 79,3 bar (1150 psi)
- Bodies for flow lines from 3/4" to 2"

## APPLICATIONS

- Pump staging or failure
- Pipeline flow detection
- Valve failure
- Loss of pipeline flow
- Pipe blockage/rupture
- Pump inlet flow protection
- Check valve blockage/leakage
- Alarm on eyewash or shower safety station

## Standard & tailor made designs



## AGENCY APPROVALS

Agency	Approval
ATEX	II 2G Ex d IIC T6 Gb, flameproof enclosure II 1G EEx ia IIC T6, intrinsically safe
CCE <sup>①</sup>	explosion proof and intrinsically safe
FM	Class I, Div. 1, Groups C & D Class II, Div. 1, Groups E, F & G, Type NEMA 7/9
FM/CSA <sup>②</sup>	Non-Hazardous area Explosion proof area – Groups B, C, D, E, F & G Type NEMA 4X/7/9
IEC	Ex d IIC T6
LRS	Lloyds Register of Shipping (marine applications)
Russian Authorisation Standards <sup>②</sup>	
Other approvals are available, consult factory for more details	

<sup>①</sup> For CCE approved units, use the ATEX model numbers.

<sup>②</sup> Consult factory for proper model numbers and classifications.

# PRINCIPLE OF OPERATION

## F10

The actuating vane is magnetically linked to a pivoted electric (or pneumatic) switch, which is isolated from the process by a non-magnetic barrier tube. As the actuating vane moves with an increase in flow, it drives a magnetic sleeve into the field of a permanent magnet located outside the barrier tube which trips the switch. As flow decreases, the actuating vane returns to a vertical position, allowing the magnet and switch assembly to return to the "No Flow" position.

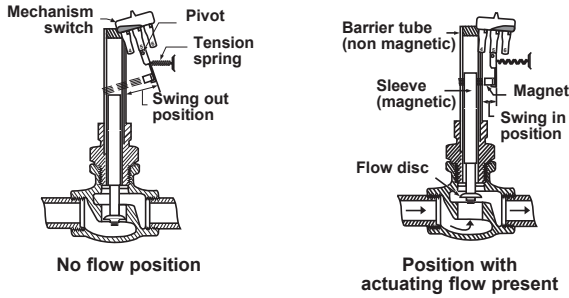
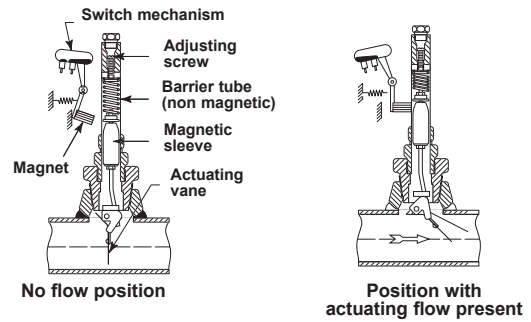

## F50

The rate of flow through the valve body raises or lowers the disc. This in turn raises or lowers the magnetic sleeve, within its sealed non-magnetic barrier tube. On an increasing flow rate, the magnetic sleeve rises into the field of the permanent magnet, located outside the barrier tube, actuating the attached switch mechanism. When the flow rate drops, below the rate for which the flow disc is calibrated, a reversal of this action occurs.

# MOUNTING

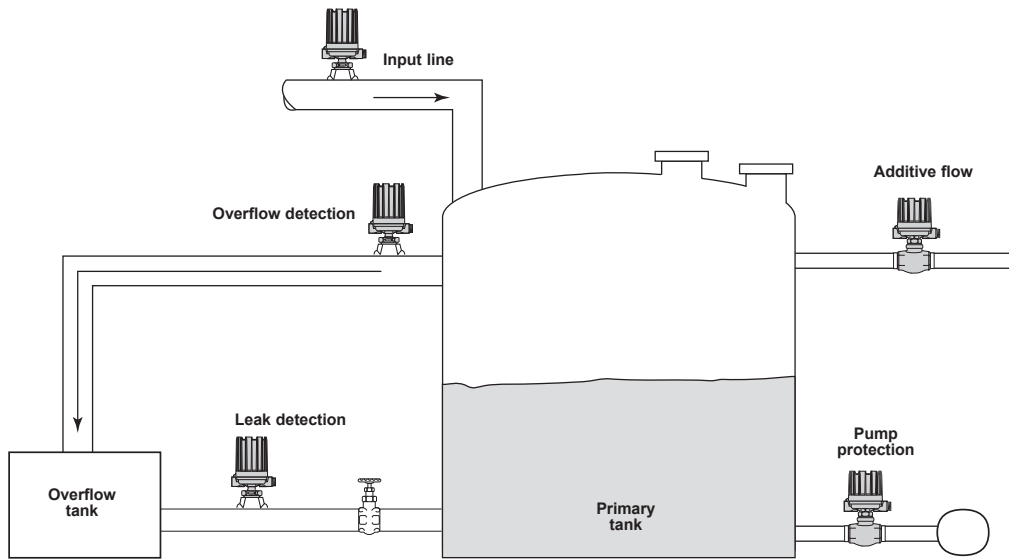

# ELECTRICAL SPECIFICATIONS

Description	Specification
Switch ratings	Up to 15 A @ 240 V AC (depending on switch mechanism) Up to 10 A @ 120 V DC (depending on switch mechanism)
Signal Output	Single SPDT or DPDT contacts or single pneumatic
Switch Types (see table on page 3)	Dry contact with standard or gold alloy contacts, Mercury, Hermetically sealed, Hermetically sealed with gold or silver plated contacts, Proximity switch, or single pneumatic bleed and non bleed
Approvals (see table on page 1)	ATEX II 2G Ex d II C T6 Gb, explosion proof ATEX II 1G EEx ia II C T6, intrinsically safe IEC Ex d II C T6, explosion proof FM/CSA, explosion proof LRS, Lloyds Register of Shipment (marine applications) EAC, Russian Authorisation standards Other approvals are available, consult factory.
Cable entries	M20 x 1,5 ISO, 1" NPT and 3/4" NPT (or others at request)

## AVAILABLE SWITCH MECHANISMS

Type of switch module <sup>①</sup>	Max. Process Temp. <sup>②</sup>		Switch ratings – A res. <sup>③</sup>			Code
	F10	F50 <sup>⑤</sup>	24 V DC	240 V AC	120 V AC	
Micro switch	max +120 °C (+250 °F)		6	15	15	B
Micro switch	max +230 °C (+450 °F)		10	15	15	C
Micro switch - DC current	max +120 °C (+250 °F)		10	–	10	D
Micro switch with gold alloy contacts	max +120 °C (+250 °F)		1	–	1	U
Hermetically sealed micro switch	max +230 °C (+450 °F)	not applicable	5	5	5	HS <sup>④</sup>
Hermetically sealed micro switch with silver plated contacts	max +230 °C (+450 °F)		3	1	1	W
Hermetically sealed micro switch with gold plated contacts	max +230 °C (+450 °F)		0,5	0,5	0,5	X
Hermetically sealed micro switch	not applicable	max +400 °C (+750 °F)	4	–	2,5	F
Proximity switch - type SJ 3.5 SN	max +100 °C (+210 °F)		NA	NA	NA	V
Pneumatic bleed type (open air)	max +200 °C (+400 °F)		NA	NA	NA	J
Pneumatic non bleed type (closed circuit)	max +200 °C (+400 °F)		NA	NA	NA	K

<sup>①</sup> For applications with heavy vibration, consult factory for suited switch modules.

<sup>②</sup> Max process temperature is specified at +40 °C (+100 °F) ambient temperature and for non condensing applications.

<sup>③</sup> For more details - see bulletin BE 42-120.

<sup>④</sup> For condensing applications, max process temperature is down-rated to +200 °C (+400 °F) @ +40 °C (+100 °F) ambient.

<sup>⑤</sup> For bronze construction, max process temperature is downrated to +260 °C (+500 °F).

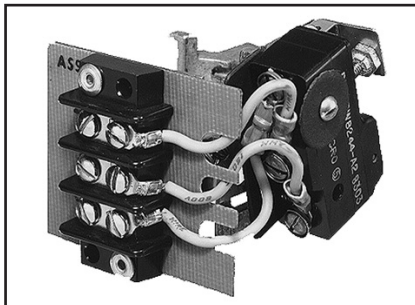

Type B, C, D & U



Type HS

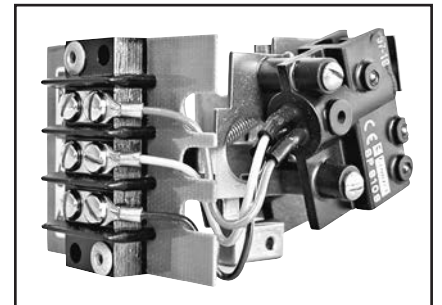

Type F, W & X

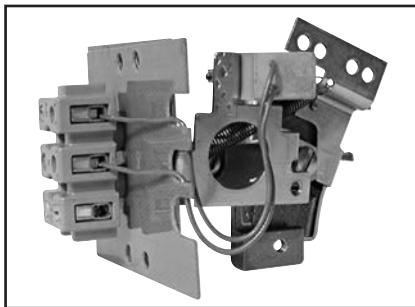

Type V



Type J & K

## AVAILABLE HOUSINGS



- For Non Ex use
- IP 66
- Die cast Aluminium
- 2 Entries (one plugged)
- Standard blue anti corrosive coating
- Housing heater/drain available, consult factory



- For Exd/Exi use
- IP 66
- Die cast Aluminium
- 2 Entries (one plugged)
- Standard blue anti corrosive coating
- ATEX II 2G Ex d II C T6 Gb
- ATEX II 1G EEx ia II C T6
- IEC Ex d II C T6



- For Exd use
- IP 66
- Cast Iron
- One entry (2 entries at request)
- Standard blue anti corrosive coating
- ATEX II 2G Ex d II C T6 Gb



- For pneumatic switches
- IP 53 (NEMA 3R)
- IP 55 optional at request
- Alu base / cold rolled steel cover
- Standard blue anti corrosive coating



- For Exd use
- IP 66 (NEMA 7/9)
- Die cast Aluminium
- 2 Entries (one plugged)
- Standard blue anti corrosive coating
- FM, Class I, Div. 1, Groups C & D
- FM, Class II, Div. 1, Groups E, F & G

## SELECTION DATA – F10

### Actuating flow rates (water service) – m<sup>3</sup>/h

Model F10 units may be adjusted in service to actuate within the minimum and maximum flow rates given below (based on schedule 40 pipe). A specific gravity correction factor is applied for liquids other than water (1.00 specific gravity).

Pipe size inches	Flow				Pipe size inches	Flow			
	increase		decrease			increase		decrease	
	Min.	Max.	Min.	Max.		Min.	Max.	Min.	Max.
2.00	4.8	14.3	3.6	10.9	14.00	61.3	97.6	38.6	63.6
2.50	5.2	16.8	4.5	12.7	16.00	77.2	115.8	49.9	72.6
3.00	7.3	20.0	5.4	14.8	18.00	97.6	133.9	61.3	84.0
3.50	8.6	22.7	6.4	17.0	20.00	118.0	156.6	72.6	97.6
4.00	10.2	27.2	7.5	19.3	22.00	140.7	177.1	86.3	109.0
5.00	13.8	34.1	9.8	25.0	24.00	165.7	204.3	102.2	124.9
6.00	17.9	40.9	12.5	29.5	26.00	193.0	233.8	118.0	140.7
8.00	27.2	52.2	18.6	36.3	28.00	222.5	263.3	133.9	158.9
10.00	38.6	70.4	25.0	47.7	30.00	252.0	292.8	152.1	177.1
12.00	52.2	86.3	34.1	56.8					

For higher/lower flow rates, consult factory.

### Specific gravity correction for actuating flow rates – m<sup>3</sup>/h

To determine the actuating flow rates for liquids other than water (approximate viscosity of 20 cP or less) a specific gravity correction factor must be applied to the water flow rates given in the table.

Specific Gravity	Multiplication Factor	Specific Gravity	Multiplication Factor
0.40	1.58	0.95	1.03
0.45	1.49	1.00	1.00
0.50	1.41	1.05	0.98
0.55	1.35	1.10	0.95
0.60	1.29	1.15	0.93
0.65	1.24	1.20	0.91
0.70	1.20	1.25	0.89
0.75	1.15	1.30	0.88
0.80	1.12	1.35	0.86
0.85	1.08	1.40	0.85
0.90	1.05	1.45	0.83

## PHYSICAL SPECIFICATIONS – F10

Description	Specification	
Measured variable	Flow rate	
Physical range	Increasing flow	From 4,8 m <sup>3</sup> /h (2" pipe size) up to 292,8 m <sup>3</sup> /h (30" pipe size)
	Decreasing flow	From 3,6 m <sup>3</sup> /h (2" pipe size) up to 177,1 m <sup>3</sup> /h (30" pipe size)
Process temperature Process pressure (for higher ratings & steam applications; consult factory)	Up to 69 bar @ +230 °C (1000 psi @ +450 °F)	
Process connection material	Carbon steel or stainless steel	
Wetted materials	Vane	302 SST (1.4300) or 304 SST (1.4301)
	Trim and magnetic sleeve	316 SST (1.4401)

## EXPEDITE SHIP PLAN (ESP)

Several mechanical switches are available for quick shipment, within max. 4 weeks after factory receipt of purchase order, through the Expedite Ship Plan (ESP).

Models covered by ESP service are conveniently grey coded in the selection data charts.

To take advantage of ESP, simply match the grey coded model number codes (standard dimensions apply).

ESP service may not apply to orders of five units or more. Contact your local representative for lead times on larger volume orders, as well as other products and options.

## SELECTION DATA – F10

Select pneumatic switch mechanism & enclosure

Pneumatic switch type	Max supply pressure bar (psi)	Max liquid temperature °C (°F)	Bleed orifice Ø mm (inches)	NEMA 3R (IP 53)
Series J (open air)	6,9 (100)	+200 (+400)	1,60 (0.063)	JGF
	4,1 (60)	+200 (+400)	2,39 (0.094)	JHF
Series K (closed circuit)	6,9 (100)	+200 (+400)	–	KOF

# SELECTION DATA – F10

## A complete measuring system consists of:

- Order code for **F10** models
- Order code for **modified** models or adders: put an "X" in front of the closest matching order code and specify the modifications/adders separately  
eg. XF10-AD22-BK9      X = with material certification EN 10204 / DIN 50049-3.1.B

- Order code for F10 flow switch

### BASIC MODEL NUMBER

F	1	0	vane actuated flow switch – field adjustable setpoint
---	---	---	---

Consult factory for steam applications.

### MATERIALS OF CONSTRUCTION

Code	Process connection material	Vane	Trim and magnetic sleeve
A	Carbon steel	302 SST (1.4300) or 304 SST (1.4301)	316 SST (1.4401)
D	316 SST (1.4401)		

### PIPE SIZE AND PROCESS CONNECTION

	Pipe size	Process connection
D 2 2	2"	2" NPT
D 2 4	4"	2" NPT
D 2 6	6"	2" NPT
D 2 8	8"	2" NPT
D 2 0	10"	2" NPT
E 5 4	4"	2 1/2" - 150 lbs RF
E 5 6	6"	2 1/2" - 150 lbs RF
E 5 8	8"	2 1/2" - 150 lbs RF
E 5 0	10"	2 1/2" - 150 lbs RF

	Pipe size	Process connection
E 6 4	4"	2 1/2" - 300 lbs RF
E 6 6	6"	2 1/2" - 300 lbs RF
E 6 8	8"	2 1/2" - 300 lbs RF
E 6 0	10"	2 1/2" - 300 lbs RF

	Pipe size	Process connection
E 7 4	4"	2 1/2" - 600 lbs RF
E 7 6	6"	2 1/2" - 600 lbs RF
E 7 8	8"	2 1/2" - 600 lbs RF
E 7 0	10"	2 1/2" - 600 lbs RF

SWITCH MECHANISM & ENCLOSURE - for electric switch mechanisms (see below)  
- for pneumatic switch mechanisms (see left page)



complete order code for **F10** models

### Select electric switch mechanism & enclosure

qty and switch type	Weather proof (IP 66)		ATEX/IEC (IP 66)		ATEX (IP 66)				FM (IP 66)	
			II 2G Ex d II C T6 Gb		II 1G EEx ia II C T6		II 2G Ex d II C T6 Gb		NEMA 7/9	
	cast Aluminium		cast Aluminium		cast Aluminium		cast Iron		cast Alu.	
	M20 x 1,5	1" NPT	M20 x 1,5	1" NPT	M20 x 1,5	1" NPT	M20 x 1,5	3/4" NPT	1" NPT	
B	1 x SPDT	B2B	BAB	BK9	BC9	-	-	BK5	BU5	BKB
	1 x DPDT	B8B	BDB	BN9	BF9	-	-	BD5	BW5	BNB
C	1 x SPDT	C2B	CAB	CK9	CC9	C2T	CAT	CK5	CU5	CKB
	1 x DPDT	C8B	CDB	CN9	CF9	C8T	CDT	CD5	CW5	CNB
D	1 x SPDT	D2B	DAB	DK9	DC9	-	-	DK5	DU5	DKB
	1 x DPDT	D8B	DDB	DN9	DF9	-	-	DD5	DW5	DNB
HS	1 x SPDT	H7A	HM2	HFC	HA9	-	-	HB3	HB4	HM3
	1 x DPDT	H7C	HM6	HGC	HB9	-	-	HB7	HB8	HM7
U	1 x SPDT	U2B	UAB	UK9	UC9	U2T	UAT	UK5	UU5	UKB
	1 x DPDT	U8B	UDB	UN9	UF9	U8T	UDT	UD5	UW5	UNB
V	-	-	-	-	-	VCS	VES	-	-	-
W	1 x SPDT	W2B	WAB	WK9	WC9	W2T	WAT	WK5	WU5	WKB
	1 x DPDT	W8B	WDB	WN9	WF9	W8T	WDT	WD5	WW5	WNB
X	1 x SPDT	X2B	XAB	XK9	XC9	X2T	XAT	XK5	XU5	XKB
	1 x DPDT	X8B	XDB	XN9	XF9	X8T	XDT	XD5	XW5	XNB

## SELECTION DATA – F50

**Specific gravity correction for actuating flow rates – m<sup>3</sup>/h**  
 To determine the actuating flow rates for liquids other than water (approximate viscosity of 20 cP or less), a specific gravity correction factor must be applied to the water flow rates given in the table. For gas/air applications, consult factory.

Specific Gravity	Multiplication Factor	Specific Gravity	Multiplication Factor
0.40	1.58	0.95	1.03
0.45	1.49	1.00	1.00
0.50	1.41	1.05	0.98
0.55	1.35	1.10	0.95
0.60	1.29	1.15	0.93
0.65	1.24	1.20	0.91
0.70	1.20	1.25	0.89
0.75	1.15	1.30	0.88
0.80	1.12	1.35	0.86
0.85	1.08	1.40	0.85
0.90	1.05	1.45	0.83

## PRESSURE DROP TABLES – F50

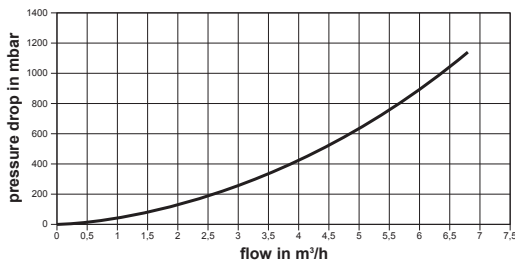

3/4" NPT connection

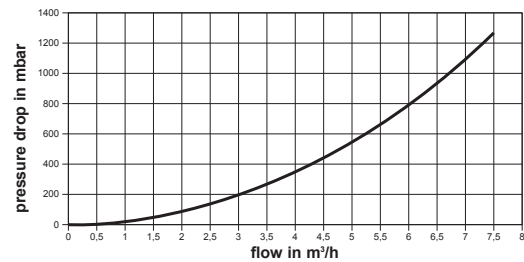

1" NPT connection

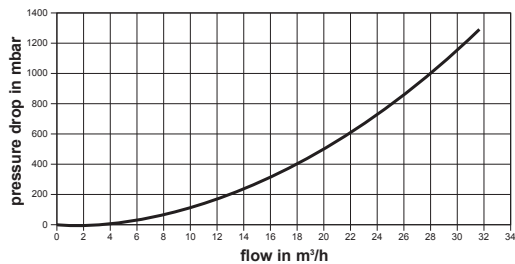

1 1/2" NPT connection

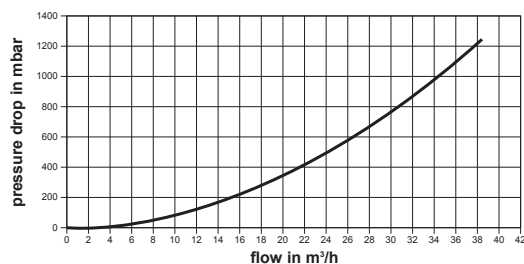

2" NPT connection

## PHYSICAL SPECIFICATIONS – F50

Description		Specification
Measured variable		Flow rate
Physical range	Increasing flow	From 0,25 m <sup>3</sup> /h (3/4" pipe size) up to 5,63 m <sup>3</sup> /h (2" pipe size)
	Decreasing flow	From 0,18 m <sup>3</sup> /h (3/4" pipe size) up to 4,77 m <sup>3</sup> /h (2" pipe size)
Process temperature Process pressure (for higher ratings consult factory)	Bronze models	Up to 27,6 bar @ +40 °C (400 psi @ +100 °F) Up to +260 °C @ 13,8 bar (+500 °F @ 200 psi)
	Stainless steel models	Up to 79,3 bar @ +40 °C (1150 psi @ +100 °F) Up to +400 °C @ 41,3 bar (+750 °F @ 600 psi)
Body material		Bronze or stainless steel
Wetted materials	Disc and trim	316 SST (1.4401)
	Magnetic sleeve	316 SST (1.4401) or 400 series SST

## SELECTION DATA – F50

Select pneumatic switch mechanism & enclosure

Pneumatic switch type	Max supply pressure bar (psi)	Max liquid temperature °C (°F)	Bleed orifice Ø mm (inches)	NEMA 3R (IP 53)	
				material code A <sup>①</sup>	material code D
Series J (open air)	6,9 (100)	+200 (+400)	1,60 (0.063)	JDG	JDE
	4,1 (60)	+200 (+400)	2,39 (0.094)	JEG	JEE
Series K (closed circuit)	6,9 (100)	+200 (+400)	–	KOE <sup>②</sup>	KOE
	2,8 (40)	+200 (+400)	–	KOG	–

<sup>①</sup> Use switch codes with material code D for F50-AC2E / F50-AC2F / F50-AD2E / F50-AD2F

<sup>②</sup> Only in combination with F50-AC2E / F50-AC2F / F50-AD2E / F50-AD2F

# SELECTION DATA – F50

**A complete measuring system consists of:**

- Order code for **F50** models.
- Order code for **modified** models or adders: put an "X" in front of the closest matching order code and specify the modifications/adders separately  
eg. XF50-AB2C-A2P      X = process connection 1" - 150 lbs RF ANSI flanges

1. Order code for F50 flow switch

**BASIC MODEL NUMBER**

F	5	0	mechanical disc actuated flow switch
---	---	---	--------------------------------------

## MATERIALS OF CONSTRUCTION

Code	Body material	Flow disc and trim	Magnetic sleeve
A	Bronze & carbon steel nut	300 series SST	400 series SST
D	316 SST (1.4401)	316 SST (1.4401)	316 SST (1.4401)

## PROCESS CONNECTION AND ACTUATING FLOW RATES

	Process connection	Actuating flow rate	
		increasing	decreasing
A 2 B	3/4" NPT	0,25 m³/h	0,18 m³/h
A 2 C	3/4" NPT	0,36 m³/h	0,27 m³/h
A 2 D	3/4" NPT	0,52 m³/h	0,41 m³/h
A 2 E	3/4" NPT	0,77 m³/h	0,59 m³/h
A 2 F	3/4" NPT	1,11 m³/h	0,84 m³/h
B 2 A	1" NPT	0,23 m³/h	0,18 m³/h
B 2 B	1" NPT	0,39 m³/h	0,32 m³/h
B 2 C	1" NPT	0,57 m³/h	0,48 m³/h
B 2 D	1" NPT	0,84 m³/h	0,68 m³/h
B 2 E	1" NPT	1,25 m³/h	1,02 m³/h
B 2 F	1" NPT	1,61 m³/h	1,32 m³/h

	Process connection	Actuating flow rate	
		increasing	decreasing
C 2 A	1 1/2" NPT	0,30 m³/h	0,25 m³/h
C 2 B	1 1/2" NPT	0,61 m³/h	0,52 m³/h
C 2 C	1 1/2" NPT	1,07 m³/h	0,91 m³/h
C 2 D	1 1/2" NPT	1,73 m³/h	1,48 m³/h
C 2 E	1 1/2" NPT	2,79 m³/h	2,38 m³/h
C 2 F	1 1/2" NPT	4,79 m³/h	4,06 m³/h
D 2 A	2" NPT	0,43 m³/h	0,36 m³/h
D 2 B	2" NPT	0,70 m³/h	0,61 m³/h
D 2 C	2" NPT	1,16 m³/h	0,98 m³/h
D 2 D	2" NPT	1,91 m³/h	1,61 m³/h
D 2 E	2" NPT	3,25 m³/h	2,75 m³/h
D 2 F	2" NPT	5,63 m³/h	4,77 m³/h

**SWITCH MECHANISM & ENCLOSURE** - for electric switch mechanisms (see below)  
- for pneumatic switch mechanisms (see left page)

F 5 0 2 complete order code for F50 models

Select electric switch mechanism & enclosure

qty and switch type	All models with material code A ①										All models with material code D									
	Weather proof (IP 66)		ATEX/IEC (IP 66)				ATEX (IP 66)				FM (IP 66)		Weather proof (IP 66)		ATEX (IP 66)				FM (IP 66)	
	II 2G Ex d IIC T6 Gb		II 1G EEx ia II C T6		II 2G Ex d IIC T6 Gb		II 1G EEx ia II C T6		II 2G Ex d IIC T6 Gb		NEMA 7/9		II 2G Ex d IIC T6 Gb		II 1G EEx ia II C T6		II 2G Ex d IIC T6 Gb		NEMA 7/9	
	cast Aluminium	cast Aluminium	cast Aluminium	cast Aluminium	cast Iron	cast Iron	cast Iron	cast Iron	cast Iron	cast Iron	cast Alu.	cast Alu.	cast Aluminium	cast Aluminium	cast Aluminium	cast Iron	cast Iron	cast Iron	cast Iron	cast Alu.
B	1 x SPDT	B2P	BAP	BHC	BAC	-	-	BK7	BU7	BKP	B2Q	BAQ	BH9	BA9	-	-	BK5	BU5	BKQ	
	1 x DPDT	B8P	BDP	BJC	BBC	-	-	BD7	BW7	BNP	B8Q	BDQ	BJ9	BB9	-	-	BD5	BW5	BNQ	
C	1 x SPDT	C2P	CAP	CHC	CAC	C2L	CAL	CK7	CU7	CKP	C2Q	CAQ	CH9	CA9	C2S	CAS	CK5	CU5	CKQ	
	1 x DPDT	C8P	CDP	CJC	CBC	C8L	CDL	CD7	CW7	CNP	C8Q	CDQ	CJ9	CB9	C8S	CDS	CD5	CW5	CNQ	
D	1 x SPDT	-	-	-	-	-	-	-	-	-	D2Q	DAQ	DH9	DA9	-	-	DK5	DU5	DKQ	
	1 x DPDT	-	-	-	-	-	-	-	-	-	D8Q	DDQ	DJ9	DB9	-	-	DD5	DW5	DNQ	
F	1 x SPDT	F2P	FAP	FHC	FAC	-	-	FK7	FU7	FKP	F2Q	FAQ	FH9	FA9	-	-	FK5	FU5	FKQ	
	1 x DPDT	F8P	FDP	FJC	FBC	-	-	FD7	FW7	FNP	F8Q	FDQ	FJ9	FB9	-	-	FD5	FW5	FNQ	
U	1 x SPDT	U2P	UAP	UHC	UAC	U2L	UAL	UK7	UU7	UKP	U2Q	UAQ	UH9	UA9	U2S	UAS	UK5	UU5	UKQ	
	1 x DPDT	U8P	UDP	UJC	UBC	U8L	UDL	UD7	UW7	UNP	U8Q	UDQ	UJ9	UB9	U8S	UDS	UD5	UW5	UNQ	
V	-	-	-	-	-	VFS	VHS	-	-	-	-	-	-	-	V5S	VBS	-	-	-	
W	1 x SPDT	W2P	WAP	WHC	WAC	W2L	WAL	WK7	WU7	WKP	W2Q	WAQ	WH9	WA9	W2S	WAS	WK5	WU5	WKQ	
	1 x DPDT	-	-	-	-	-	-	-	-	-	W8Q	WDQ	WJ9	WB9	W8S	WDS	WD5	WW5	WNQ	
X	1 x SPDT	X2P	XAP	XHC	XAC	X2L	XAL	XK7	XU7	XKP	X2Q	XAQ	XH9	XA9	X2S	XAS	XK5	XU5	XKQ	
	1 x DPDT	-	-	-	-	-	-	-	-	-	X8Q	XDQ	XJ9	XB9	X8S	XDS	XD5	XW5	XNQ	

① Use switch codes with material code D for F50-AC2E / F50-AC2F / F50-AD2E / F50-AD2F

# DIMENSIONS in mm (inches)

Pipe size	Dim. A max.	Equivalent max. wall schedule	Dim. B
2"	46 (1.81)	80	40 (1.59)
2 1/2"	49 (1.94)	160	53 (2.09)
3"	48 (1.88)	80	68 (2.66)
3 1/2"	48 (1.88)	80	79 (3.12)
4"	51 (2.00)	120	94 (3.69)
5"	52 (2.06)	120	118 (4.66)
6"	54 (2.12)	120	145 (5.72)
8"	56 (2.19)	100	195 (7.69)
10"	59 (2.31)	100	254 (10.00)
over 10"	59 (2.31)	-	

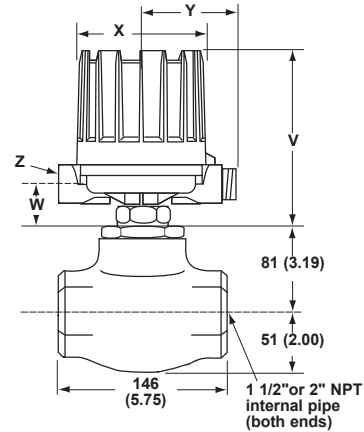
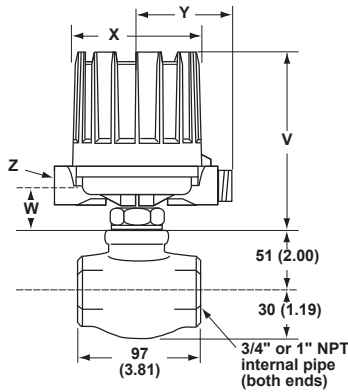
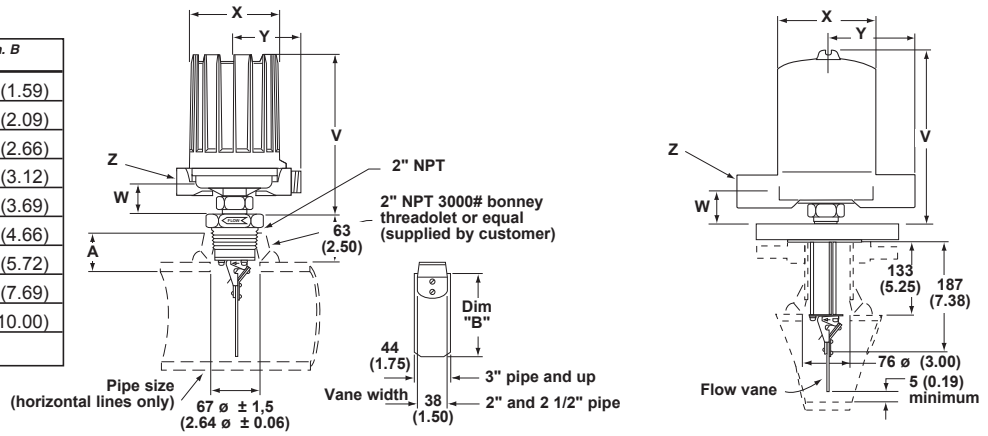

Housing type	Models	V		W		ø X		Y		Z
		mm	inches	mm	inches	mm	inches	mm	inches	
Weatherproof-FM (NEMA 7/9) - ATEX (Cast Alu)	F10	257	10.12	42	1.66	151	5.93	109	4.29	M20 x 1,5 (*) or 1" NPT (2 entries - 1 plugged) (*) not for FM (NEMA 7/9)
	F50	202	7.94							
ATEX (Cast Iron)	All	249	9.80	45	1.77	143	5.63	110	4.33	M20 x 1,5 or 3/4" NPT (single entry - 2 entries at request)
Pneumatics Switch Module J	F10	216	8.50	39	1.54	118	4.65	110	4.33	1/4" NPT
	F50	165	6.50							
Pneumatics Switch Module K	F10	216	8.50	39	1.54	118	4.65	130	5.12	1/4" NPT
	F50	165	6.50							

Allow 200 mm (7.87") overhead clearance / All housings are 360 ° rotatable



### QUALITY ASSURANCE - ISO 9001

THE QUALITY ASSURANCE SYSTEM IN PLACE AT MAGNETROL GUARANTEES THE HIGHEST LEVEL OF QUALITY DURING THE DESIGN, THE CONSTRUCTION AND THE SERVICE OF CONTROLS. OUR QUALITY ASSURANCE SYSTEM IS APPROVED AND CERTIFIED TO ISO 9001 AND OUR TOTAL COMPANY IS COMMITTED TO PROVIDING FULL CUSTOMER SATISFACTION BOTH IN QUALITY PRODUCTS AND QUALITY SERVICE.

### PRODUCT WARRANTY

ALL MAGNETROL MECHANICAL LEVEL CONTROLS ARE WARRANTED FREE OF DEFECTS IN MATERIALS AND WORKMANSHIP FOR THREE FULL YEARS FROM THE DATE OF ORIGINAL FACTORY SHIPMENT.

IF RETURNED WITHIN THE WARRANTY PERIOD; AND, UPON FACTORY INSPECTION OF THE CONTROL, THE CAUSE OF THE CLAIM IS DETERMINED TO BE COVERED UNDER THE WARRANTY; THEN, MAGNETROL INTERNATIONAL WILL REPAIR OR REPLACE THE CONTROL AT NO COST TO THE PURCHASER (OR OWNER) OTHER THAN TRANSPORTATION.

MAGNETROL SHALL NOT BE LIABLE FOR MISAPPLICATION, LABOR CLAIMS, DIRECT OR CONSEQUENTIAL DAMAGE OR EXPENSE ARISING FROM THE INSTALLATION OR USE OF THE EQUIPMENT. THERE ARE NO OTHER WARRANTIES EXPRESSED OR IMPLIED, EXCEPT, SPECIAL WRITTEN WARRANTIES COVERING SOME MAGNETROL PRODUCTS.

UNDER RESERVE OF MODIFICATIONS

BULLETIN N°: BE 47-116.8  
EFFECTIVE: SEPTEMBER 2015  
SUPERSEDES: December 2014



**MAGNETROL**

**AMETEK**  
SENSORS, TEST & CALIBRATION