

Flow Meter TZ1-...E



- Large analog display
- Monitor and display
- Simple adjustment by means of drag indicator
- Can be used from nominal width DN 40..100

Characteristics

Mechanical flow meter, for fluid or gaseous media, with no-contact triggering of an display device with 270 ° pointer deflection. Robust construction in brass or stainless steel.

Technical data

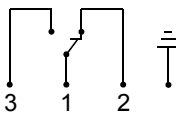
Switch	optionally micro switch	
Nominal width	DN 40..100	
Process connection	installation flange DIN 2527 DN 32 PN 16 sealing surface as per DIN 2526 form C	
Metering range	50..1050 l/min	for details see table "Ranges and dimensions"
Q_{max.}	up to 1400 l/min	
Tolerance	±5 % of full scale value	
Pressure resistance	PN 16 bar	
Medium temperature	-20..+90 °C, optionally -20..+200 °C, type TZ1X on request	
Ambient temperature	-20..+70 °C	
Media	water (oils available on request)	
Wiring	changeover no. 0.342	
		
Switching voltage	max. 250 V AC	
Switching current	max. 5 A	
Protection class	2 - safety insulation	
Ingress protection	IP 65	
Electrical connection	plug DIN 43650-A / ISO 4400	

Materials medium-contact	<i>Brass construction:</i> Rg 5, CW614N nickelled, 1.4305, 1.4301, 1.4310, 1.4571, NBR, hard ferrite	<i>Stainless steel construction:</i> 1.4305, 1.4301, 1.4310, 1.4571, FKM, hard ferrite
Non-medium-contact materials	CW614N chromed, steel chromed, Acrylic, NBR	
Weight	3 kg	
Installation location	Standard: horizontal inwards flow; display downwards and inwards flow from above not recommended; other installation positions are possible; the installation position affects the switching point and display range.	

Ranges and dimensions

Details in the table correspond to horizontal inwards flow with increasing flow rate.

DN	Metering range l/min H ₂ O	Q _{max.} Recom- mended	Types	Paddle form	L
DN 40	50 - 250	450	TZ1-040G.250	1	93
	100 - 350		TZ1-040G.350		87
DN 50	80 - 350	450	TZ1-050G.350	1	98
	100 - 450		TZ1-050G.450		
DN 65	100 - 350	550	TZ1-065G.350	1	111
	150 - 500		TZ1-065G.500		101
DN 80	130 - 450	900	TZ1-080G.450	1	126
	200 - 600		TZ1-080G.600		112
DN 100	300 - 800	1400	TZ1-100G.800	2	158
	350 - 1050		TZ1-100G.1050		148

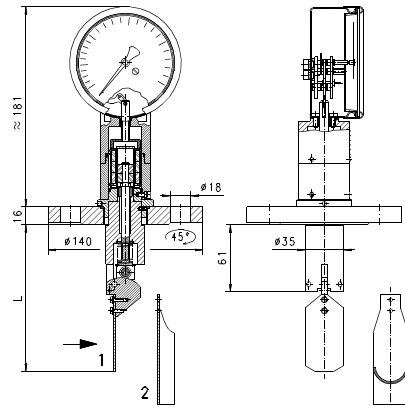

Attention! Flange seal not included in scope of delivery

PÁDLOVÝ PRŮTOKOMĚŘ TZ1



HENNLICH

MERES

Handling and Operation

Note

- Include straight calming section of 10 x DN in inlet and outlet
- If the media are dirty, install a filter (use magnetic filter for ferritic components).
- It must be ensured that the values given for voltage, current, and power are not exceeded.
- When switched on, a load must be connected in series.
- The electrical details apply to ohmic loads. Capacitive and inductive loads must be operated using a protective circuit.

Loosen adjustment

The microswitch (optional) is adjusted by means of the knurled adjusting screw provided. The screw allows the drag indicator to be set to the desired switching value. The value displayed corresponds to a switching point for a decreasing flow rate.



Installation recommendation

Use a tube with standard wall thickness as per DIN 2448

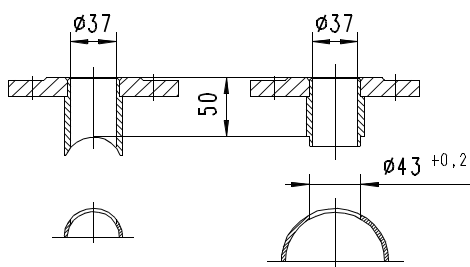

The type FL installation flanges are available as an accessory.

Ordering code

TZ1 1. 2. 3. 4. 5.

E

○=Option

1. Additional devices			
-	only analog display		
M-	with integrated micro switch		
P-	○ with potentiometer	see „Additional devices for TZ1”	
M2-	○ with 2 x normally open (n.o.)		
M3-	○ with 2 x normally closed (n.c.)		
2. Nominal width			
040	DN 40		
050	DN 50		
065	DN 65		
080	DN 80		
100	DN 100		
3. Process connection			
E	installation flange		
4. Connection material			
M	brass		
K	stainless steel		
5. Metering range H ₂ O for horizontal inwards flow			
250	50 - 250 l/min		●
350	80 - 350 l/min		●
	100 - 350 l/min		●
450	100 - 450 l/min		●
	130 - 450 l/min		●
500	150 - 500 l/min		●
600	200 - 600 l/min		●
800	300 - 800 l/min	●	
1050	350 - 1,050 l/min		

Options

- Metering ranges for oil
- Special values
- Gold contact
 - min: 5 V DC, 1 mA
 - max: 125 V AC, 30 V DC, 1 A
- Special Harting plug

Ordering information

- Specify direction of flow, medium, and metering range.
- For oils. State viscosity, temperature and designation (e.g. ISO VG 68) (enquire about metering range).