

xiros[®]

Polymer ball bearings



...plastics

xiros® polymer ball bearings | Application examples

Other exciting applications ► www.igus.eu/xiros-applications

Labelling machine

Depending on the size of the system, between 12 and 36 guide rollers are used in the SleeveMatic's film storage. Two xiros® ball bearings are used per guide roller. (Krones AG)



Thermoforming machine

In this Thermoforming machine for coffee-cream portion packs, xiros® A500 plastic ball bearings are used for their high chemical resistance. (frischli Milchwerke GmbH)



Bike wash system

To mount the washing brushes, the manufacturer of the "cycleWash" has used two xiros® slewing ring ball bearings with stainless steel balls. The bearing rings consist of the wear-resistant ball bearing material xirodure® B180.



Wet film thickness gauge

This precision tester for accurate and rapid measurement of all liquid paint, coatings, oil coatings and adhesives is equipped with a durable and solvent-resistant xiros® B180 polymer ball bearing.



Film guide rollers

There is no contamination of the films through lubricants, due to the use of maintenance-free xiros® flange bearings.



Pellet ovens

Two lubrication-free polymer ball bearings are used in the mechanical drive unit. These ensure that the pellets are fed into the combustion chamber via the roller. (Erwin Koppe – Keramische Heizgeräte GmbH)

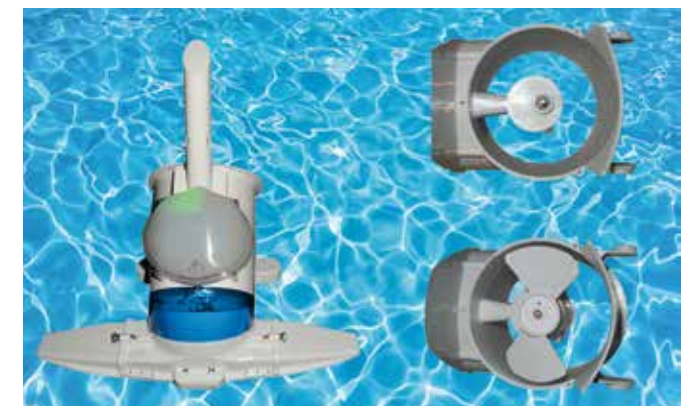

Pool cleaner

xiros® B180 polymer ball bearings from igus® allow pool cleaners a lubrication-free underwater operation. Resistant to chemicals, lightweight and maintenance-free.

xiros® radial deep groove ball bearings – standard product range



The classic:
PA cage
▶ Page 886



Cost-effective and FDA-compliant:
B180 cage
▶ Page 886



FDA-compliant:
PE cage
▶ Page 886



With shield or labyrinth seal:
LCC with B180 cage
▶ Page 892



Black (for visible parts):
xirodur® S180,
PA cage
▶ Page 886



High resistance to chemicals:
xirodur® C160, PP cage
▶ Page 894



For high temperatures up to +120°C:
xirodur® A500, PA cage
▶ Page 898



For heat and chemicals:
xirodur® A500,
PEEK cage
▶ Page 898

xiros® radial deep groove ball bearings – standard product range



Lightweight and non-metallic:
xirodur® A500, PAI balls
▶ Page 898



Antistatic:
xirodur® F180,
PA cage
▶ Page 902



Antistatic and FDA-compliant:
xirodur® F180, PE cage
▶ Page 902



Conductive:
xirodur® F182,
PA cage
▶ Page 904



High speeds:
xirodur® D180,
PA cage
▶ Page 906



Detectable:
xirodur® M180,
xirodur® M180 cage
▶ Page 907



For the tobacco industry:
xirodur® T220,
PP cage
▶ Page 908



For temperatures up to +120°C:
xirodur® G220, PP cage
▶ Page 909

xiros® radial deep groove ball bearings – further materials

xiros® radial deep groove ball bearings with flange and guide rollers



Single flange:
xirodur® B180,
PA cage
▶ Page 910



With double flange:
xirodur® B180,
PA cage
▶ Page 910



Antistatic:
xirodur® F180,
PA cage
▶ Page 910



Guide roller:
Aluminium tube
▶ Page 912



Guide roller:
Plastic approved for food contact
▶ Page 913

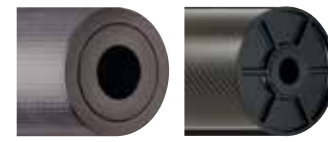

Guide roller:
Carbon fibre tube with ball bearing
▶ Page 914



End caps:
xirodur® B180,
PA cage
▶ Page 916

xiros® – other designs



With profile:
xirodur® B180
▶ Page 918



Spherical radial deep groove ball bearings:
xirodur® B180
▶ Page 919



Double row for higher loads:
xirodur® B180
▶ Page 920



Multi-axis bearing:
xirodur® B180,
PP balls
▶ Page 921



Skate wheel:
xirodur® B180,
PA cage
▶ Page 922



Fixed flange ball bearing, FDA-compliant, fixed version:
xirodur® B180
▶ Page 923



Polymer balls transfer units:
wxirodur® B180 and F182
▶ Page 924



Axial polymer ball transfer units:
with spherical roller
▶ Page 926

xiros® thrust bearings and slewing ring ball bearings



Single row:
xirodur® B180,
glass/stainless steel balls
▶ Page 928



Double row:
xirodur® B180,
glass/PAI/stainless steel balls
▶ Page 928



Thrust bearing:
xirodur® B180,
glass/stainless steel balls
▶ Page 929



Slewing ring ball bearings:
xirodur® B180,
with gear teeth or with cage
▶ Page 930



Pillow block ball bearing, FDA-compliant, fixed version:
xirodur® B180
▶ Page 932



Pillow block ball bearing, fixed or pivoting
▶ Page 934



4-hole fixed flange ball bearing, pivoting
▶ Page 936



2-hole fixed flange ball bearing, pivoting
▶ Page 937

xiros® combinations with igubal®

Lubrication and maintenance-free

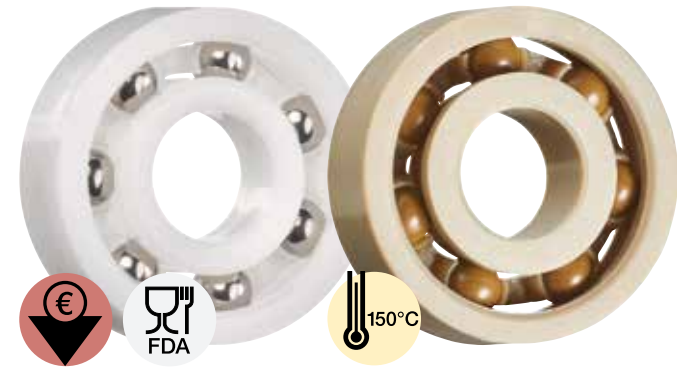

Lubrication-free polymer ball bearings

xiros® polymer ball bearings revolutionise the ball bearing market. Thanks to their maintenance-free dry operation and the use of xirodur® high-performance polymers, many applications can be successfully implemented in which conventional metal ball bearings are not suitable.

- Lubrication and maintenance-free
- Corrosion-resistant
- Non-metallic (due to the use of glass and plastic balls), therefore non-magnetic
- For temperatures up to +150°C (depending on material)
- High media resistance, suitable for washdown
- Lightweight
- Electrically insulating (or ESD-compliant)
- FDA-compliant (depending on material)
- Predictable service life

Typical application areas

- Packaging
- Textile industry
- Test engineering and quality assurance
- Optical industry
- Model making

Available from stock
Detailed information about delivery time online.

Price breaks online
No minimum order value. No minimum order quantity.

max. +150°C
min. -100°C

10 xirodur® materials
Ø 3–60mm

Imperial dimensions available
▶ **Page 1611**

Service life calculation
▶ **www.igus.eu/xiros-expert**

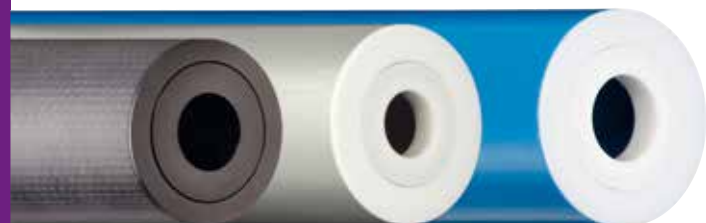
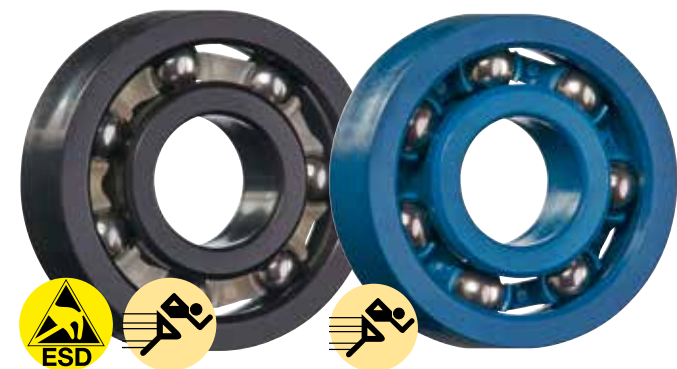

Overview types



xiros® radial deep groove ball bearings – standard product range for 3 materials:

- xirodur® B180 – cost-effective standard
 - xirodur® C160 – resistant to chemicals
 - xirodur® A500 – for heat and chemicals
- ▶ **From page 886**

xiros® radial deep groove ball bearings with flange and guide rollers

- With single or double flange
 - Made from xirodur® B180 or F180
 - xiros® system solution: Aluminium, PVC or carbon fibre tube with 2 fixed flange ball bearings
- ▶ **From page 910**



xiros® radial deep groove ball bearings – materials for special applications

- xirodur® M180 – detectable
- xirodur® T220 – for the tobacco industry
- xirodur® G220 – for temperatures up to +120°C
- xirodur® S180 – black (for visible parts)

- xirodur® F180 – antistatic
 - xirodur® F182 – conductive
 - xirodur® D180 – high speeds
- ▶ **From page 907**



xiros® radial deep groove ball bearings – further designs

- With spherical outer diameter
 - Double row for higher loads
 - Multi-axis bearing for rotary and linear movements
- ▶ **From page 918**

xiros® thrust bearing

- For absorbing axial loads
 - Various options
- ▶ **From page 928**



xiros® slewing ring ball bearings

- With glass or stainless steel balls
 - Outer toothed profile
 - With cage
- ▶ **From page 930**



xiros® combinations with igubal®

- Fixed or pivoting versions
 - For maintenance-free use in conveyor belts and guide rollers
- ▶ **From page 934**

Radial deep groove ball bearings design

The xiros® polymer ball bearings are single-row deep groove ball bearings based on DIN 625. The lubrication and maintenance-free ball bearings consist of four components:

The outer and inner races

The suitability of a xiros® polymer ball bearings is largely determined by the materials of the two races. These are made from igus® tribo-polymers to maximise service life and minimise friction. Choice of 5 materials. They allow different values of application temperature, media resistance and price. The table of materials (► Page 824) provides exact information on this topic.

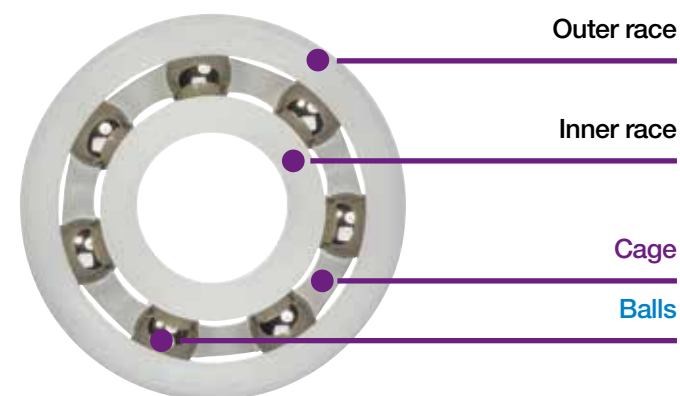

The cage

The material of the ball bearing cage must fit well to the application. The various material options have quite different chemical and temperature resistance values. The cage materials are compatible with all the different race options within xiros®.

The balls

The ball materials differ most significantly. In addition to steel, glass or plastics are used. This produces a large difference in mass, which in turn affects inertia, weight and chemical resistance. Stainless steel balls (1.4401) are cost-effective, resistant to chemicals and suitable for high temperatures, but are the heaviest in the range. Glass balls (soda-lime glass) are also resistant to chemicals and have a medium weight. Just like polymer balls, they are non-metallic and non-magnetic. In addition to their excellent chemical resistance, the polymer balls (PAI) are even lighter than stainless steel or glass balls.

Other designs

xiros® radial deep groove ball bearings

The other designs include:

- Convex rollers which can run directly on a profile
- Profiled rollers, e.g. for thread/cable guidance
- Thrust and slewing ring ball bearings for absorbing axial loads
- Multi-axis bearings for linear and radial movements
- Ball bearings designed e.g. for installation in tube ends (also for guide rollers)
- Double-row bearings for absorbing higher forces

Pillow block and fixed flange bearings

This range is made up by combining xiros® polymer ball bearings with the igubal® pillow block and fixed flange housings, resulting in a higher flexibility in terms of installation of the bearings. The bearing housings make it easy for the user to install these maintenance-free components. Both fixed flange and pillow block bearings are available as fixed or as pivoting design. The difference between the two options is that the pivoting type can compensate for shaft and/or bearing misalignment. A spherical outer race is pressed into the bearing housing, ensuring self-aligning action. If necessary, the inner bearing can be pivoted in all directions. Possible misalignment of two bearing points lying together can thus be compensated for.

Measurement requirement for injection-moulded xiros® polymer ball bearings

The outer race of our ball bearings has a conical shape. This simplifies the installation in a suitable housing (with the narrow side first). After press-fit into a housing machined to a H7 tolerance the bearing clearance is reduced. Therefore the bearings must be measured over the entire width of the ball bearing. Starting at an angle of 90° from the injection point.

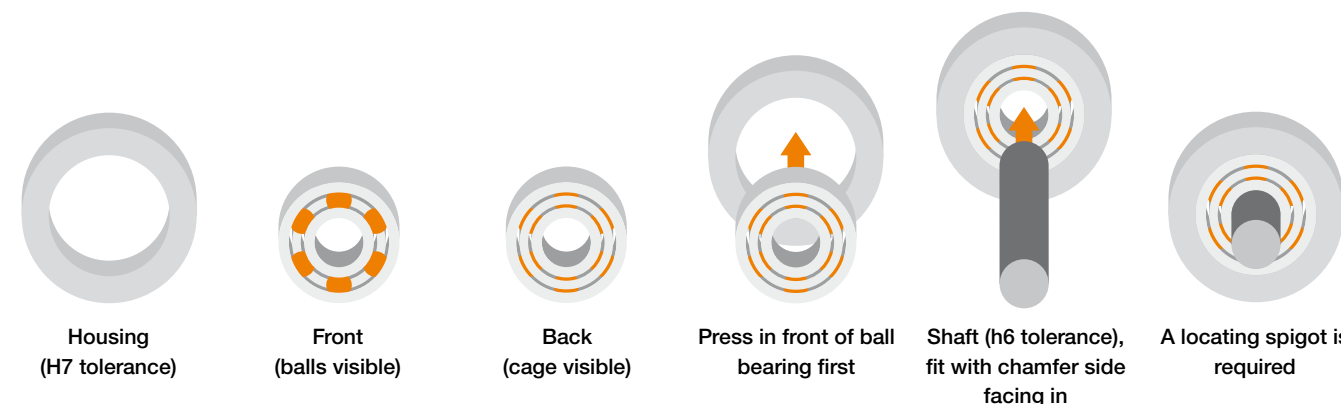

To press in the xiros® polymer ball bearing over the entire width of the housing, apply pressure on the outer race. xiros® radial deep groove ball bearings are only suitable for limited axial loads.

Development and tests

Through numerous tests the race materials were optimised. The polymers we have developed for use with ball bearings allow higher speeds, greater loads, and longer service life. But the development continues. We believe that polymer ball bearing technology will continue to advance, especially with our experience in the development of tribological polymer materials. Challenge us, talk to us about your applications, tell us what you need from a polymer ball bearing. In the igus® test laboratory the service life and wear of xiros® polymer ball bearings are tested. In addition to the actual material comparison, tests indicate these experiments also answer questions about the impact of external influences such as temperature, humidity or dust.



igus® extends the xiros® test stand in the industry's largest test laboratory for plastics in motion

Predictability

As part of the development of xiros® polymer ball bearing tests are carried out continuously. The high number of test results makes it very difficult to present this information in tabular form. It is for this reason that igus® has developed the online service life calculator, which uses real test results to give an accurate calculation.

The predictability of xiros® polymer ball bearings is one of the most important advantages. Based on the results of many wear tests, the user can calculate the service life of xiros® polymer ball bearings reliably and interpret the application.



► www.igus.eu/xiros-expert

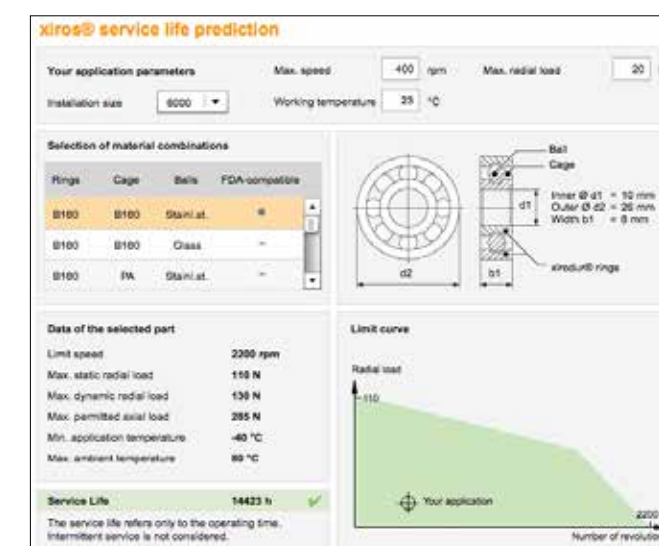

Download the online tool app now



xiros® polymer ball bearings | Technical data

Material properties and chemical resistance

General properties	Unit	xirodur®			
		B180	S180	C160	A500
Density	g/cm³	1.41	1.40	1.11	1.30
Colour		white	black	opaque	brown
Max. moisture absorption at +23°C/50% r.h.	% weight	0.2	0.2	0.1	0.1
Max. total moisture absorption	% weight	0.7	0.7	0.2	0.4
Mechanical properties					
Flexural modulus	MPa	2,500	2,700	1,900	4,300
Flexural strength at +20°C	MPa	68	65	35	130
Shore D hardness		77	78	67	85
Electrical properties					
Specific volume resistance ¹⁾	Ωcm	> 10 ¹⁴	> 10 ¹³	> 10 ¹⁴	> 10 ¹⁴
Surface resistance ¹⁾	Ω	> 10 ¹⁴	> 10 ¹³	> 10 ¹⁴	> 10 ¹⁴
Thermal properties of xiros® polymer ball bearings ¹⁾					
Max. long-term application temperature	°C	+80	+80	+60	+150 (PEEK) +120 (PA)
Min. long-term application temperatures (in combination with cage material)	°C	-40	-40	0	-100 (PEEK) -40 (PA)

¹⁾ Depending on the geometry

Table 01: Material data

Medium	xirodur®			
	B180	S180	C160	A500
Alcohols	+	+	+	+
Greases, oils without additives	+	+	+	+
Hydrocarbons	+	+	+ up to 0	+
Fuels	+	+	+ up to 0	+
Strong alkali	+ up to 0	+ up to 0	+	+
Strong acid	-	-	+ up to 0	+
UV radiation	-	0	0	+
Diluted base	+	+	+	+
Diluted acid	0 to -	0 to -	+	+

+ resistant 0 conditionally resistant - non-resistant

Table 02: Chemical resistance of xiros® materials

Detailed chemicals resistance table for xiros® products ► From page 1636

Recommended tolerances

Fitting	Housing hole	Shaft
Standard:	H7	h6
Press-fit		

For further questions about the dimensioning of the hole and the shaft please contact us.

F180	F182	xirodur®				G220	igumid G
		D180	M180	T220	G220		
1.36	1.42	1.22	1.67	1.28	1.14	1.37	
black	black	blue	blue	beige	grey	black	
0.2	0.2	0.5	0.2	0.3	2.1	1.4	
1.3	0.7	1.4	0.6	0.5	8.9	5.6	
1,600	3,000	135	2,500	1,800	3,000	7,800	
70	95	n.a.	68	65	n.a.	240	
79	79	48	77	76	n.a.	79	
< 10 ¹² ¹⁾	< 10 ⁴	> 10 ¹⁴	> 10 ⁹	> 10 ¹⁰	> 10 ¹³	> 10 ¹¹	
< 10 ¹² ¹⁾	< 10 ⁴	> 10 ¹⁴	> 10 ⁹	> 10 ¹⁰	> 10 ¹²	> 10 ¹¹	
+80	+80	+80	+80	+100	+100	+120	
-40	-40	-50	-40	-40	-40	-40	

F180	F182	xirodur®				G220	igumid G
		D180	M180	T220	G220		
+	+	+ up to 0	+	+	0	+	
+	+	+	+	+	+	+	
+	+	+	+	+	+	+	
+	+	+	+	+	+	+	
+ up to 0	+ up to 0	+ up to 0	+ up to 0	+ up to 0	+ up to 0	-	
-	-	0	-	-	-	+ up to 0	
0	0	-	-	+	-	-	
+	+	+ up to 0	+	+	+	0 to -	
0 to -	0 to -	+ up to 0	0 to -	0 to -	0 to -	+	

Ball materials

Description	Specification
ES: Stainless steel	1.4401
GL: glass	Soda-lime glass or borosilicate glass
PAI: plastic	Polyamide-imide
PP: plastic	Polypropylene

xiros® polymer ball bearings | Selection guide

According to material properties

xirodur®	B180				S180	C160	
Cage material	PA		B180		PE	PA	PP
Ball material	ES	GL	ES	GL	ES	ES	ES
Descriptive technical specifications							
Smooth running	●	●	●	●	●	●	●
Low moisture absorption	●	●	●	●	●	●	●
Chemical resistance			●	●	●		●
Seawater-resistant			●	●			●
Dirt-resistant	●	●	●	●	●	●	●
Higher temperatures							
Higher speeds							
Cost-effective			●	●			
Approvals and standards							
For contact with food			●		●		
Antistatic							
Conductive							
Non-metallic		●		●			●
Detectable							
Availabilities / variants							
Radial deep groove ball bearings	●	●	●	●	●	●	●
Radial deep groove ball bearings with flange	●	●	●	●			
End cap	●	●					
Spherical outer diameter	●	●					
Double row	●	●					
Slewing ring ball bearings			●				
Thrust bearing			●	●			

A500					F180		F182	D180	M180	T220	G220
PA		PEEK			PA	PE	PA	PA	M180	PP	PA
ES	GL	ES	GL	PAI	ES	ES	ES	ES	ES	ES	ES
●	●	●	●	●	●	●	●		●	●	
●	●	●	●	●	●	●	●		●	●	
		●	●	●							
		●	●								
●	●	●	●	●	●	●	●		●	●	
●	●	●	●	●							●
								●			
		●				●			●		
					●	●					
	●		●	●							
									●		
●	●	●	●	●	●	●	●	●	●	●	●
					●						

FDA



xirodur® B180 cage, stainless steel balls



xirodur® B180 cage, glass balls



PA cage, stainless steel balls



PA cage, glass balls

FDA



PE cage, stainless steel balls



Also available with S180 races for visible parts (xirodur® S180 and PA cage)

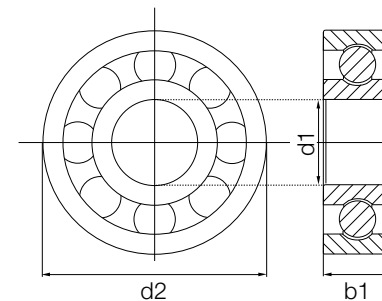

Order key

Type	Material
Ball bearings	Dimensions according to DIN 625-1
Race material	Cage material
Ball material	

BB-623-B180-10-ES

Options:

- Cage material
 - 10 = PA
 - 30 = xirodur® B180
 - 50 = PE
- Ball material
 - ES = Stainless steel
 - GL = Glass
- Race material
 - xirodur® B180
 - xirodur® S180

Imperial dimensions available ▶ Page 1611

Technical data

Installation size	Radial load capacity		Max. speed [rpm]	Weight				
	stat. [N]	dyn. [N]		B180/ES [g]	B180/GL [g]	PA/ES [g]	PA/GL [g]	PE/ES [g]
623	25	34	4,500	0.37	0.31	0.40	0.32	0.39
633	33	45	4,000	0.83	0.64	-	-	-
684	10	11	4,600	0.26	0.20	-	-	-
694	12	14	4,000	0.42	0.35	-	-	-
604	30	32	3,600	0.65	0.45	-	-	-
624	33	45	4,000	0.79	0.60	0.85	0.62	0.83
634	40	40	3,700	1.50	1.00	-	-	-
685	12	14	4,000	0.45	0.37	-	-	-
695	29	30	3,500	0.73	0.53	-	-	-
605	32	33	3,500	0.96	0.77	-	-	-
625	40	40	3,700	1.42	0.96	1.55	1.01	1.52
635	41	43	3,200	2.59	1.76	-	-	-
686	29	30	3,500	0.76	0.57	-	-	-
696	29	30	3,500	1.05	0.85	-	-	-
606	50	53	3,300	1.89	1.25	-	-	-
626	60	62	3,200	2.06	1.60	2.44	1.69	2.35
636	80	94	2,200	3.96	2.71	-	-	-
687	32	34	3,200	0.80	0.61	-	-	-
697	39	41	3,000	1.47	1.05	-	-	-
607	41	43	3,200	1.97	1.52	-	-	-
627	80	94	2,400	3.85	2.60	-	-	-
688	39	41	3,000	1.17	0.76	1.19	0.75	-
698	60	62	3,200	2.34	1.52	-	-	-
608	80	94	2,400	3.76	2.51	3.79	2.54	3.73

Dimensions [mm]

Inner Ø d1	Outer Ø d2	Width b1	Cage/ball material combination					Part No.
			B180/ES	B180/GL	PA/ES	PA/GL	PE/ES	
3	10	4	●	●	●	●	●	BB-623-B180- <input type="text"/> - <input type="text"/>
3	13	5	●	●	-	-	-	BB-633-B180- <input type="text"/>
4	9	4	●	●	-	-	-	BB-684-B180- <input type="text"/>
4	11	4	●	●	-	-	-	BB-694-B180- <input type="text"/>
4	12	4	●	●	-	-	-	BB-604-B180- <input type="text"/>
4	13	5	●	●	●	●	●	BB-624-B180- <input type="text"/> - <input type="text"/>
4	16	5	●	●	-	-	-	BB-634-B180- <input type="text"/>
5	11	5	●	●	-	-	-	BB-685-B180- <input type="text"/>
5	13	4	●	●	-	-	-	BB-695-B180- <input type="text"/>
5	14	5	●	●	-	-	-	BB-605-B180- <input type="text"/>
5	16	5	●	●	●	●	●	BB-625-B180- <input type="text"/> - <input type="text"/>
5	19	6	●	●	-	-	-	BB-635-B180- <input type="text"/>
6	13	5	●	●	-	-	-	BB-686-B180- <input type="text"/>
6	15	5	●	●	-	-	-	BB-696-B180- <input type="text"/>
6	17	6	●	●	-	-	-	BB-606-B180- <input type="text"/>
6	19	6	●	●	●	●	●	BB-626-B180- <input type="text"/> - <input type="text"/>
6	22	7	●	●	-	-	-	BB-636-B180- <input type="text"/>
7	14	5	●	●	-	-	-	BB-687-B180- <input type="text"/>
7	17	5	●	●	-	-	-	BB-697-B180- <input type="text"/>
7	19	6	●	●	-	-	-	BB-607-B180- <input type="text"/>
7	22	7	●	●	-	-	-	BB-627-B180- <input type="text"/>
8	16	5	●	●	●	●	-	BB-688-B180- <input type="text"/> - <input type="text"/>
8	19	6	●	●	-	-	-	BB-698-B180- <input type="text"/>
8	22	7	●	●	●	●	●	BB-608-B180- <input type="text"/> - <input type="text"/>



Order example:

BB-623-B180-10-ES = Radial deep groove ball bearing with race material xirodur® B180, PA cage and stainless steel balls



Available from stock

Technical data

Installation size	Radial load capacity		Max. speed [rpm]	Weight				
	stat. [N]	dyn. [N]		B180/ES [g]	B180/GL [g]	PA/ES [g]	PA/GL [g]	PE/ES [g]
628	100	110	2,300	5.57	3.4	–	–	–
638	110	130	2,200	7.82	5.65	–	–	–
689	40	42	2,500	1.30	0.88	–	–	–
699	43	45	2,250	2.08	1.66	–	–	–
609	100	110	2,300	5.12	2.95	–	–	–
629	110	128	2,200	6.20	4.03	6.14	–	–
6800	43	45	2,250	1.56	1.07	–	–	–
6900	60	64	2,000	3.24	2.04	–	–	–
6000	110	130	2,200	5.98	3.83	5.95	3.78	5.98
6200	130	147	2,000	9.32	6.56	9.26	6.51	–
6300	140	150	1,800	13.83	11.02	13.75	–	–
6701	16	18	2,200	0.68	0.57	–	–	–
6801	60	64	2,000	1.82	1.40	–	–	–
6901	80	83	1,800	3.12	2.10	–	–	–
6001	130	147	2,000	6.36	4.18	6.78	4.34	6.66
6201	140	150	1,800	10.04	7.25	9.97	7.12	–
6301	160	220	1,600	15.69	12.90	–	–	–
6702	19	21	1,800	0.94	0.81	–	–	–
6802	80	83	1,800	2.46	1.46	–	–	–
6902	90	94	1,700	4.37	3.12	–	–	–
6002	140	150	1,800	8.68	5.92	8.72	6.23	8.60
6202	160	220	1,600	11.71	8.96	12.26	9.11	12.10
6302	250	320	1,400	10.56	3.95	10.49	–	–
6703	23	25	1,600	0.66	–	–	–	–
6803	90	94	1,700	2.83	1.65	–	–	–
6903	90	94	1,700	–	0.79	–	–	–
6003	160	220	1,600	10.23	7.45	10.72	7.61	10.55
6203	250	320	1,400	19.36	12.75	17.45	12.68	–
6303	280	360	1,200	21.68	13.60	–	–	–
6704	30	36	1,400	1.39	1.17	–	–	–
6804	100	120	1,500	5.19	3.59	–	–	–
6904	140	144	1,150	9.76	–	–	–	–
6004	250	320	1,400	20.81	12.93	19.46	12.89	19.44
6204	280	360	1,200	30.22	22.14	28.87	22.33	–
6304	380	400	1,000	43.85	31.05	–	–	–
6705	32	38	1,200	1.58	1.40	–	–	–
6805	140	144	1,150	6.48	4.16	–	–	–
6905	160	162	900	4.49	4.49	–	–	–
6005	280	360	1,200	24.14	16.07	22.93	15.67	22.58
6205	310	370	1,000	35.99	27.92	34.82	27.51	–
6305	480	520	850	61.12	45.48	–	–	–



Order example:

BB-628-B180-30-ES = Radial deep groove ball bearing with race material xirodur® B180, xirodur® B180 cage and stainless steel balls

Dimensions [mm]

Inner Ø d1	Outer Ø d2	Width b1	Cage/ball material combination					Part No.
			B180/ES	B180/GL	PA/ES	PA/GL	PE/ES	
8	24	8	●	●	–	–	–	BB-628-B180-30-□
8	28	9	●	●	–	–	–	BB-638-B180-30-□
9	17	5	●	●	–	–	–	BB-689-B180-30-□
9	20	6	●	●	–	–	–	BB-699-B180-30-□
9	24	7	●	●	–	–	–	BB-609-B180-30-□
9	26	8	●	●	●	–	–	BB-629-B180-□-□
10	19	5	●	●	–	–	–	BB-6800-B180-30-□
10	22	6	●	●	–	–	–	BB-6900-B180-30-□
10	26	8	●	●	●	●	●	BB-6000-B180-□-□
10	30	9	●	●	●	●	–	BB-6200-B180-□-□
10	35	11	●	●	●	–	–	BB-6300-B180-□-□
12	18	4	●	●	–	–	–	BB-6701-B180-30-□
12	21	5	●	●	–	–	–	BB-6801-B180-30-□
12	24	6	●	●	–	–	–	BB-6901-B180-30-□
12	28	8	●	●	●	●	●	BB-6001-B180-□-□
12	32	10	●	●	●	●	–	BB-6201-B180-□-□
12	37	12	●	●	–	–	–	BB-6301-B180-30-□
15	21	4	●	●	–	–	–	BB-6702-B180-30-□
15	24	5	●	●	–	–	–	BB-6802-B180-30-□
15	28	7	●	●	–	–	–	BB-6902-B180-30-□
15	32	9	●	●	●	●	●	BB-6002-B180-□-□
15	35	11	●	●	●	●	●	BB-6202-B180-□-□
15	42	13	●	●	●	–	–	BB-6302-B180-□-□
17	23	4	●	–	–	–	–	BB-6703-B180-30-ES
17	26	5	●	●	–	–	–	BB-6803-B180-30-□
17	30	7	–	●	–	–	–	BB-6903-B180-30-GL
17	35	10	●	●	●	●	●	BB-6003-B180-□-□
17	40	12	●	●	●	●	–	BB-6203-B180-□-□
17	47	14	●	●	–	–	–	BB-6303-B180-30-□
20	27	4	●	●	–	–	–	BB-6704-B180-30-□
20	32	7	●	●	–	–	–	BB-6804-B180-30-□
20	37	9	●	–	–	–	–	BB-6904-B180-30-ES
20	42	12	●	●	●	●	●	BB-6004-B180-□-□
20	47	14	●	●	●	●	–	BB-6204-B180-□-□
20	52	15	●	●	–	–	–	BB-6304-B180-30-□
25	32	4	●	●	–	–	–	BB-6705-B180-30-□
25	37	7	●	●	–	–	–	BB-6805-B180-30-□
25	42	9	●	●	–	–	–	BB-6905-B180-30-□
25	47	12	●	●	●	●	●	BB-6005-B180-□-□
25	52	15	●	●	●	●	–	BB-6205-B180-□-□
25	62	17	●	●	–	–	–	BB-6305-B180-30-□



Available
from stock

Technical data

Installation size	Radial load capacity		Max. speed [rpm]	Weight				
	stat. [N]	dyn. [N]		B180/ES [g]	B180/GL [g]	PA/ES [g]	PA/GL [g]	PE/ES [g]
6706	34	41	1,000	1.76	1.59	–	–	–
6806	160	162	900	4.49	1.82	–	–	–
6906	190	193	850	13.15	10.13	–	–	–
16006	380	420	900	–	–	28.53	17.33	–
6006	380	400	1,000	–	–	34.15	22.70	–
6206	480	520	850	55.89	39.73	–	–	–
6306	520	660	750	27.00	8.52	–	–	–
6007	480	520	850	–	–	47.29	30.71	–
6008	520	660	750	–	–	54.84	38.73	–
6009	660	690	650	–	–	33.52	57.52	–
6010	740	780	600	–	–	82.33	54.00	–
6011	930	950	550	–	–	119.64	75.80	–
6012	990	1,050	500	–	–	126.66	80.54	–

Dimensions [mm]

Inner Ø d1	Outer Ø d2	Width b1	Cage/ball material combination					Part No.
			B180/ES	B180/GL	PA/ES	PA/GL	PE/ES	
30	37	4	●	●	–	–	–	BB-6706-B180-30-□
30	42	7	●	●	–	–	–	BB-6806-B180-30-□
30	47	9	●	●	–	–	–	BB-6906-B180-30-□
30	55	9	–	–	●	●	–	BB-16006-B180-10-□
30	55	13	–	–	●	●	–	BB-6006-B180-10-□
30	62	16	●	●	–	–	–	BB-6206-B180-30-□
30	72	19	●	●	–	–	–	BB-6306-B180-30-□
35	62	14	–	–	●	●	–	BB-6007-B180-10-□
40	68	15	–	–	●	●	–	BB-6008-B180-10-□
45	75	16	–	–	●	●	–	BB-6009-B180-10-□
50	80	16	–	–	●	●	–	BB-6010-B180-10-□
55	90	18	–	–	●	●	–	BB-6011-B180-10-□
60	95	18	–	–	●	●	–	BB-6012-B180-10-□



Order example:

BB-6706-B180-30-ES = Thin ring bearing with race material xirodur® B180, xirodur® B180 cage and stainless steel balls



Available from stock



PA cage, with shield on one side stainless steel or glass balls

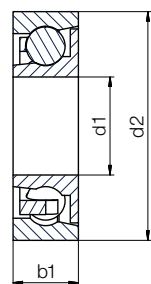

B180 cage, with labyrinth seal, stainless steel balls

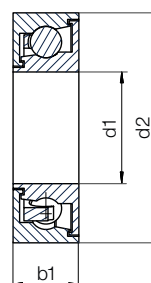

Technical data

Installation size	Radial load capacity		Max. speed [rpm]	Weight	
	stat. [N]	dyn. [N]		stainless steel [g]	glass [g]
623	10	25	4,500	0.41	0.33
626	41	43	3,200	2.56	1.71
608	80	94	2,200	3.93	2.67
6000	110	130	2,200	6.21	4.15
6001	138	147	2,000	7.09	4.61
6202	142	155	1,700	12.73	9.63
6003	160	220	1,600	11.12	8.03
6004	250	320	1,400	20.20	13.60
6005	280	360	1,200	23.89	16.51

With labyrinth seal

Installation size	Radial load capacity		Max. speed [rpm]	Weight	
	stat. [N]	dyn. [N]		stainless steel [g]	glass [g]
6003	160	220	1,600	11.02	8.27



Order example:

BB-623-B180-10-ES-C = Radial deep groove ball bearing with race material xirodur® B180, PA cage, stainless steel balls and shield



Order key

Type	Material
Ball bearings	Options: Cage material 10 = PA 30 = xirodur® B180 Ball material ES = Stainless steel GL = Glass Shield or labyrinth seal C = One-sided shield LCC = Labyrinth seal
Dimensions according to DIN 625-1	
Race material	
Cage material	
Ball material	
With shield	

Dimensions [mm]

Inner Ø d1	Outer Ø d2	Width b1	Cage/ball material combination		Part No.
			PA/ES	PA/GL	
3	10	4	●	●	BB-623-B180-10-□-C
6	19	6	●	●	BB-626-B180-10-□-C
8	22	7	●	●	BB-608-B180-10-□-C
10	26	8	●	●	BB-6000-B180-10-□-C
12	28	8	●	●	BB-6001-B180-10-□-C
15	35	11	●	●	BB-6202-B180-10-□-C
17	35	10	●	●	BB-6003-B180-10-□-C
20	42	12	●	●	BB-6004-B180-10-□-C
25	47	12	●	●	BB-6005-B180-10-□-C

Dimensions [mm]

Inner Ø d1	Outer Ø d2	Width b1	Cage/ball material combination		Part No.
			B180/ES	B180/GL	
17	35	10	●	●	BB-6003-B180-30-□-LCC



Available from stock



PP cage,
stainless steel
balls



PP cage,
glass balls

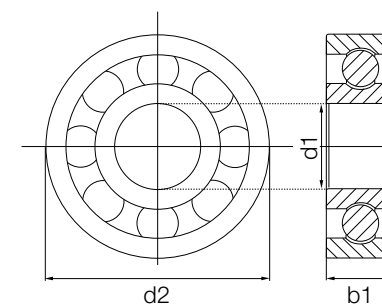

Order key

Type	Material
Ball bearings	Dimensions according to DIN 625-1
Face material	Cage material
	Ball material

BB-623-C160-20-ES

Cage material
20 = PP
Options:
Ball material
ES = Stainless steel
GL = Glass

Technical data

Installation size	Radial load capacity		Max. speed [rpm]	Weight	
	stat. [N]	dyn. [N]		PP/ES [g]	PP/GL [g]
623	10	11	4,000	0.35	0.26
624	12	13	3,650	–	–
625	20	22	3,100	–	0.21
635	30	31	2,900	1.76	1.03
626	30	34	2,600	2.15	1.43
636	40	42	2,050	2.06	–
627	40	43	2,000	–	–
688	20	21	2,750	1.06	0.24
608	40	46	2,200	3.37	2.21
628	57	61	1,800	–	–
638	60	62	1,670	6.27	4.10
629	60	63	1,680	–	–
6800	20	24	2,100	–	–
6000	60	65	1,700	5.48	3.33
6200	78	81	1,540	7.50	4.71
6801	30	32	1,920	0.84	0.92
6001	70	74	1,580	6.59	3.80
6201	80	83	1,260	–	–
6802	40	43	1,700	–	0.46
6002	80	85	1,500	5.72	4.86
6202	80	85	1,130	–	–
6803	50	51	1,650	–	–
6003	90	96	1,300	9.10	6.22
6203	140	142	1,010	–	–
6804	50	54	1,480	–	–

Dimensions [mm]

Inner Ø d1	Outer Ø d2	Width b1	Cage/ball material combination		Part No.
			PP/ES	PP/GL	
3	10	4	●	●	BB-623-C160-20-□
4	13	5	●	●	BB-624-C160-20-□
5	16	5	●	●	BB-625-C160-20-□
5	19	6	●	●	BB-635-C160-20-□
6	19	6	●	●	BB-626-C160-20-□
6	22	7	●	●	BB-636-C160-20-□
7	22	7	●	●	BB-627-C160-20-□
8	16	5	●	●	BB-688-C160-20-□
8	22	7	●	●	BB-608-C160-20-□
8	24	8	●	●	BB-628-C160-20-□
8	28	9	●	●	BB-638-C160-20-□
9	26	8	●	●	BB-629-C160-20-□
10	19	5	●	●	BB-6800-C160-20-□
10	26	8	●	●	BB-6000-C160-20-□
10	30	9	●	●	BB-6200-C160-20-□
12	21	5	●	●	BB-6801-C160-20-□
12	28	8	●	●	BB-6001-C160-20-□
12	32	10	●	●	BB-6201-C160-20-□
15	24	5	●	●	BB-6802-C160-20-□
15	32	9	●	●	BB-6002-C160-20-□
15	35	11	●	●	BB-6202-C160-20-□
17	26	5	●	●	BB-6803-C160-20-□
17	35	10	●	●	BB-6003-C160-20-□
17	40	12	●	●	BB-6203-C160-20-□
20	32	7	●	●	BB-6804-C160-20-□



Order example:

BB-623-C160-20-ES = Radial deep groove ball bearing with race material xirodur® C160, PP cage and stainless steel balls



Available from stock

Upon request

Technical data

Installation size	Radial load capacity		Max. speed [rpm]	Weight	
	stat. [N]	dyn. [N]		PP/ES [g]	PP/GL [g]
6004	140	142	1,000	17.81	11.20
6204	140	145	950	22.85	4.89
6805	80	82	1,075	–	–
6005	140	151	960	20.63	13.29
6205	170	181	810	26.70	4.89

Dimensions [mm]

Inner Ø d1	Outer Ø d2	Width b1	Cage/ball material combination		Part No.
			PP/ES	PP/GL	
20	42	12	●	●	BB-6004-C160-20- <input type="text"/>
20	47	14	●	●	BB-6204-C160-20- <input type="text"/>
25	37	7	●	●	BB-6805-C160-20- <input type="text"/>
25	47	12	●	●	BB-6005-C160-20- <input type="text"/>
25	52	15	●	●	BB-6205-C160-20- <input type="text"/>



Order example:

BB-6004-C160-20-ES = Radial deep groove ball bearing with race material xirodur® C160, PP cage and stainless steel balls



Available from stock

Upon request



PA cage,
stainless steel balls



PEEK cage,
stainless steel balls



PEEK cage,
glass balls



PEEK cage,
PAI balls

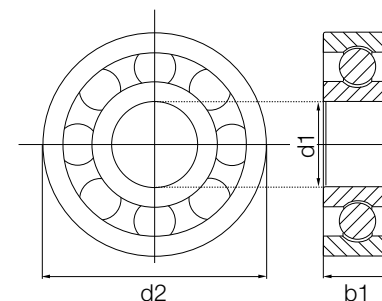

Order key

Type	Material
Ball bearings	BB-623-A500-10-ES
Dimensions according to DIN 625-1	
Race material	
Cage material	
Ball material	

Options:

- Cage material**
 - 10 = PA
 - 70 = PEEK
- Ball material**
 - ES = Stainless steel
 - GL = Glass
 - PAI = Polyamide-imide

Technical data

Installation size	Radial load capacity				Max. speed [rpm]	Weight			
	stat. [N]	dyn. [N]	stat. PEEK/PAI [N]	dyn. PEEK/PAI [N]		PA/stainless steel [g]	PEEK/stainless steel [g]	PEEK/glass [g]	PEEK/PAI [g]
623	27	30	-	-	5,000	0.4	0.4	0.3	-
624	30	40	-	-	4,500	1.9	1.0	0.9	-
625	36	43	-	-	3,700	-	-	-	-
635	48	52	-	-	3,400	-	-	-	-
626	54	60	15	20	3,400	2.3	2.3	1.6	1.4
636	72	76	-	-	2,450	-	-	-	-
627	72	74	-	-	2,600	-	-	-	-
688	36	38	-	-	3,150	-	-	-	-
608	72	78	18	25	2,700	3.7	3.7	2.4	2.2
628	98	104	-	-	2,500	-	-	-	-
638	102	108	-	-	2,300	-	-	-	-
629	102	112	-	-	2,350	-	-	-	-
6800	42	46	-	-	2,300	-	-	-	-
6000	102	107	25	34	2,100	6.0	6.0	3.8	3.4
6200	126	132	-	-	2,100	-	-	-	-
6801	54	57	-	-	2,150	-	-	-	-
6001	105	124	-	-	2,040	-	-	-	-
6201	132	141	-	-	1,820	-	-	-	-
6802	72	76	-	-	1,920	-	-	-	-
6002	132	145	32	41	1,900	9.1	9.1	5.2	5.6
6202	135	146	-	-	1,600	-	-	-	-
6803	84	84	-	-	1,760	-	-	-	-
6003	138	152	-	-	1,790	-	-	-	-
6203	228	232	-	-	1,450	-	-	-	-

Dimensions [mm]

Inner Ø	Outer Ø	Width	Cage/ball material combination				Part No.
			PA/ES	PEEK/ES	PEEK/GL	PEEK/PAI	
d1	d2	b1					
3	10	4	●	●	●	-	BB-623-A500- <input type="text"/> - <input type="text"/>
4	13	5	●	●	●	-	BB-624-A500- <input type="text"/> - <input type="text"/>
5	16	5	●	●	●	-	BB-625-A500- <input type="text"/> - <input type="text"/>
5	19	6	●	●	●	-	BB-635-A500- <input type="text"/> - <input type="text"/>
6	19	6	●	●	●	●	BB-626-A500- <input type="text"/> - <input type="text"/>
6	22	7	●	●	●	-	BB-636-A500- <input type="text"/> - <input type="text"/>
7	22	7	●	●	●	-	BB-627-A500- <input type="text"/> - <input type="text"/>
8	16	5	●	●	●	-	BB-688-A500- <input type="text"/> - <input type="text"/>
8	22	7	●	●	●	●	BB-608-A500- <input type="text"/> - <input type="text"/>
8	24	8	●	●	●	-	BB-628-A500- <input type="text"/> - <input type="text"/>
8	28	9	●	●	●	-	BB-638-A500- <input type="text"/> - <input type="text"/>
9	26	8	●	●	●	-	BB-629-A500- <input type="text"/> - <input type="text"/>
10	19	5	●	●	●	-	BB-6800-A500- <input type="text"/> - <input type="text"/>
10	26	8	●	●	●	●	BB-6000-A500- <input type="text"/> - <input type="text"/>
10	30	9	●	●	●	-	BB-6200-A500- <input type="text"/> - <input type="text"/>
12	21	5	●	●	●	-	BB-6801-A500- <input type="text"/> - <input type="text"/>
12	28	8	●	●	●	●	BB-6001-A500- <input type="text"/> - <input type="text"/>
12	32	10	●	●	●	-	BB-6201-A500- <input type="text"/> - <input type="text"/>
15	24	5	●	●	●	-	BB-6802-A500- <input type="text"/> - <input type="text"/>
15	32	9	●	●	●	●	BB-6002-A500- <input type="text"/> - <input type="text"/>
15	35	11	●	●	●	-	BB-6202-A500- <input type="text"/> - <input type="text"/>
17	26	5	●	●	●	-	BB-6803-A500- <input type="text"/> - <input type="text"/>
17	35	10	●	●	●	●	BB-6003-A500- <input type="text"/> - <input type="text"/>
17	40	12	●	●	●	-	BB-6203-A500- <input type="text"/> - <input type="text"/>

Order example:
BB-623-A500-10-ES = Radial deep groove ball bearing with race material xirodur® A500, PA cage and stainless steel balls

Available from stock
Upon request

Technical data

Installation size	Radial load capacity				Max. speed [rpm]	Weight			
	stat. [N]	dyn. [N]	PEEK/PAI			PA/ stainless steel [g]	PEEK/ stainless steel [g]	PEEK/ glass [g]	PEEK/ PAI [g]
			stat. [N]	dyn. [N]					
6804	90	93	–	–	1,560	–	–	–	–
6004	234	250	62	88	1,700	19.7	19.7	13.2	11.7
6204	234	238	–	–	1,270	–	–	–	–
6805	132	135	–	–	980	–	–	–	–
6005	405	420	–	–	1,500	–	–	–	–
6205	422	440	–	–	1,100	–	–	–	–

Dimensions [mm]

Inner Ø d1	Outer Ø d2	Width b1	Cage/ball material combination				Part No.
			PA/ES	PEEK/ES	PEEK/GL	PEEK/PAI	
20	32	7	●	●	●	–	BB-6804-A500- <input type="text"/> - <input type="text"/>
20	42	12	●	●	●	●	BB-6004-A500- <input type="text"/> - <input type="text"/>
20	47	14	●	●	●	–	BB-6204-A500- <input type="text"/> - <input type="text"/>
25	37	7	●	●	●	–	BB-6805-A500- <input type="text"/> - <input type="text"/>
25	47	12	●	●	●	●	BB-6005-A500- <input type="text"/> - <input type="text"/>
25	52	15	●	●	●	–	BB-6205-A500- <input type="text"/> - <input type="text"/>



Order example:

BB-623-A500-10-ES = Radial deep groove ball bearing with race material xirodur® A500, PA cage and stainless steel balls



Available from stock

Upon request



PA cage,
stainless steel balls



PE cage,
stainless steel balls



Special designs
made from
xirodur® F180
► Page 910

Technical data

Installation size	Radial load capacity		Max. speed [rpm]	Weight	
	stat. [N]	dyn. [N]		PA/ES [g]	PE/ES [g]
623	10	25	4,500	0.39	0.39
624	20	33	4,000	0.83	0.82
625	40	40	3,700	1.54	1.50
626	41	43	3,200	2.50	2.36
608	80	94	2,200	3.79	3.67
6000	110	130	2,200	5.86	5.76
6001	138	147	2,000	6.72	6.62
6002	140	150	1,800	8.59	8.50
6003	160	220	1,600	10.53	10.39
6004	250	320	1,400	19.24	19.18
6005	280	360	1,200	22.43	22.04

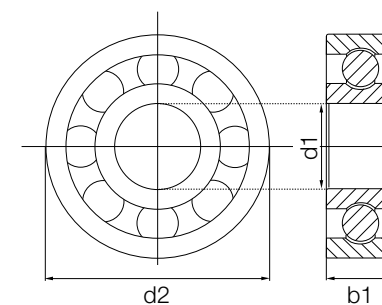

Order key

Type	Material
Ball bearings	Dimensions according to DIN 625-1
Race material	Cage material
Ball material	

Options:
Cage material
 10 = PA
 50 = PE
Ball material
 ES = Stainless steel

Dimensions [mm]

Inner Ø d1	Outer Ø d2	Width b1	Cage/ball material combination		Part No.
			PA/ES	PE/ES	
3	10	4	●	●	BB-623-F180-□-ES
4	13	5	●	●	BB-624-F180-□-ES
5	16	5	●	●	BB-625-F180-□-ES
6	19	6	●	●	BB-626-F180-□-ES
8	22	7	●	●	BB-608-F180-□-ES
10	26	8	●	●	BB-6000-F180-□-ES
12	28	8	●	●	BB-6001-F180-□-ES
15	32	9	●	●	BB-6002-F180-□-ES
17	35	10	●	●	BB-6003-F180-□-ES
20	42	12	●	●	BB-6004-F180-□-ES
25	47	12	●	●	BB-6005-F180-□-ES



Order example:

BB-623-F180-10-ES = Radial deep groove ball bearing with race material xirodur® F180, PA cage and stainless steel balls



Available
from stock



PA cage,
stainless steel balls

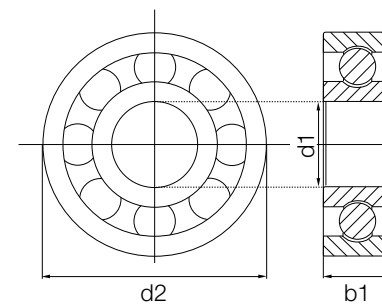

Order key

Type Material

BB-608-F182-10-ES

Ball bearings	Dimensions according to DIN 625-1	Race material	Cage material	Ball material
---------------	-----------------------------------	---------------	---------------	---------------

Cage material

10 = PA

Ball material

ES = Stainless steel

Technical data

Installation size	Radial load capacity		Max. speed [rpm]	Weight PA/ES [g]
	stat. [N]	dyn. [N]		
608	80	94	2,200	–
6000	110	130	2,200	–
6001	138	147	2,000	4.31

Dimensions [mm]

Inner Ø d1	Outer Ø d2	Width b1	Cage/ball material combination PA/ES	Part No.
8	22	7	●	BB-608-F182-10-ES
10	26	8	●	BB-6000-F182-10-ES
12	28	8	●	BB-6001-F182-10-ES



Order example:

BB-608-F182-10-ES = Radial deep groove ball bearing with race material xirodur® F182, PA cage and stainless steel balls



Available from stock

Upon request

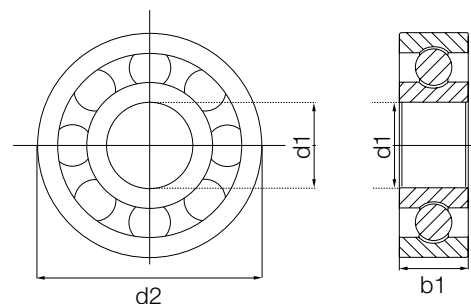
PA cage,
stainless steel balls

Order key

Type Material

BB-623-D180-10-ES



Cage material

10 = PA

Ball material

ES = Stainless steel

Technical data

Installation size	Radial load capacity		Max. speed [rpm]	Weight PA/ES [g]
	stat. [N]	dyn. [N]		
623	7	12	5,500	0.40
626	13	18	4,500	2.00
608	20	32	4,300	3.70
6000	28	36	4,200	5.78
6001	32	49	4,000	6.55
6002	44	50	3,870	8.26

Dimensions [mm]

Inner Ø d1	Outer Ø d2	Width b1	Cage/ball material combination PA/ES	Part No.
3	10	4	●	BB-623-D180-10-ES
6	19	6	●	BB-626-D180-10-ES
8	22	7	●	BB-608-D180-10-ES
10	26	8	●	BB-6000-D180-10-ES
12	28	8	●	BB-6001-D180-10-ES
15	32	9	●	BB-6002-D180-10-ES



Order example:

BB-623-D180-10-ES = Radial deep groove ball bearing with race material xirodur® D180, PA cage and stainless steel balls

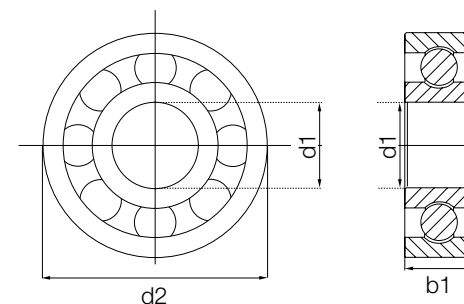

Upon request

xirodur® M180 cage,
stainless steel balls

Order key

Type Material

BB-6000-M180-40-ES

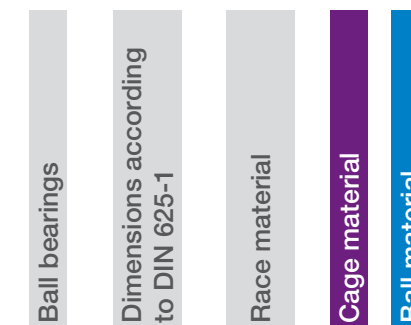

Cage material

40 = xirodur® M180

Ball material

ES = Stainless steel

Technical data

Installation size	Radial load capacity		Max. speed [rpm]	Weight M180/ES [g]
	stat. [N]	dyn. [N]		
6000	85	119	1,900	6.53
6003	180	250	1,400	11.01

Dimensions [mm]

Inner Ø d1	Outer Ø d2	Width b1	Part No.
10	26	8	BB-6000-M180-40-ES
17	35	10	BB-6003-M180-40-ES



Order example:

BB-6000-M180-40-ES = Radial deep groove ball bearing with race material xirodur® M180, M180 cage and stainless steel balls



Upon request



PP cage,
stainless steel balls

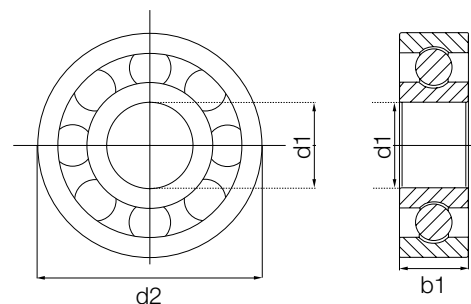

Order key

Type Material

BB-6002-T220-20-ES

Ball bearings	Dimensions according to DIN 625-1	Race material	Cage material	Ball material
---------------	-----------------------------------	---------------	---------------	---------------

Cage material
20 = PP
Ball material
ES = Stainless steel

Technical data

Installation size	Radial load capacity		Max. speed [rpm]	Weight PP/ES [g]
	stat. [N]	dyn. [N]		
6002	130	160	1,200	8.36

Dimensions [mm]

Inner Ø d1	Outer Ø d2	Width b1	Part No.
15	32	9	BB-6002-T220-20-ES



Order example:

BB-6002-T220-20-ES = Radial deep groove ball bearing with race material xirodur® T220, PP cage and stainless steel balls



Upon request



PA cage,
stainless steel balls

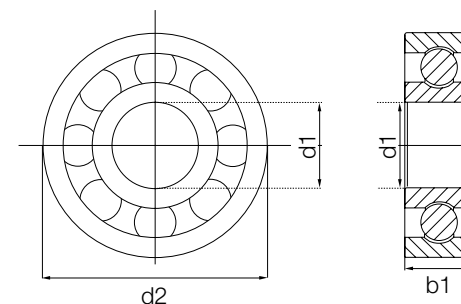

Order key

Type Material

BB-6000-G220-10-ES

Ball bearings	Dimensions according to DIN 625-1	Race material	Cage material	Ball material
---------------	-----------------------------------	---------------	---------------	---------------

Cage material
10 = PA
Ball material
ES = Stainless steel

Technical data

Installation size	Radial load capacity		Max. speed [rpm]	Weight PA/ES [g]
	stat. [N]	dyn. [N]		
6000	95	110	2,000	5.49

Dimensions [mm]

Inner Ø d1	Outer Ø d2	Width b1	Part No.
10	26	8	BB-6000-G220-10-ES



Order example:

BB-6000-G220-10-ES = Radial deep groove ball bearing with race material xirodur® G220, PA cage and stainless steel balls



Upon request

xiros® radial deep groove ball bearings with flange

xirodur® B180 or xirodur® F180

Single flange with shield



xirodur® B180, PA cage, stainless steel balls



xirodur® S180, PA cage, stainless steel balls

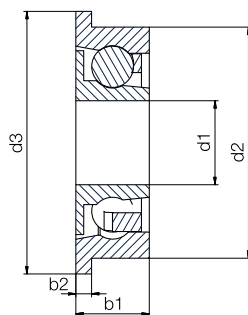

Double flange with shield



xirodur® B180 races PA cage, stainless steel or glass balls



xirodur® F180 races PA cage, stainless steel balls

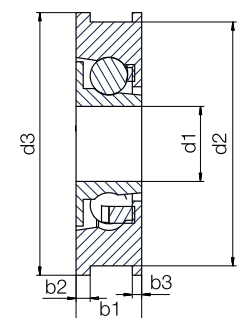

Technical data

Installation size	Double flange	Radial load capacity		Max. speed [rpm]	Weight					
		stat. [N]	dyn. [N]		B180			F180		S180
					PA/ES [g]	PA/GL [g]	B180/ES [g]	PA/ES [g]	PA/ES [g]	
Radial deep groove ball bearing with single flange with shield for guide roller										
626	-	60	62	3,200	-	-	-	-	1.32	
688	-	39	41	3,000	-	-	-	-	0.66	
608	-	80	94	2,400	-	-	-	-	2.00	
608	-	80	94	2,200	5.55	-	-	-	-	
6000	-	110	130	1,900	7.55	-	-	-	-	
6000	-	110	130	1,900	10.06	-	-	-	-	
6001	-	130	147	1,750	7.53	5.09	-	-	-	
6001	-	130	147	1,750	12.02	-	-	-	-	
6002	-	140	150	1,600	11.44	-	-	-	-	
6003	-	160	220	1,550	11.42	-	-	-	-	
6004	-	250	320	1,400	-	-	16.36	-	-	
6004	-	250	320	1,400	-	-	29.60	-	-	
Radial deep groove ball bearing with single or double flange and shields										
608	-	80	94	2,200	5.69	4.47	-	5.49	-	
608	●	80	94	2,200	5.82	5.93	-	5.61	-	



Order example:

BB-6000F2830-B180-10-ES = Radial deep groove ball bearing with single flange for system solution BBT (guide roller), race material xirodur® B180 with PA cage and stainless steel balls

Product range



Order key with single flange

Type	Material
Ball bearings	Dimensions according to DIN 625-1
Single flange	Outer Ø [mm]
Race material	Cage material
Ball material	



Also available as complete system solution ▶ Page 912



Order key with double flange

Type	Material	Design
Ball bearings	Dimensions according to DIN 625-1	Double flange
Race material	Cage material	Ball material
Double shield		

Flange

F = Single flange
FF = Double flange
Race material
F180 = xirodur® F180
B180 = xirodur® B180
S180 = xirodur® S180

Cage material

10 = PA
30 = xirodur® B180
Ball material
ES = Stainless steel
GL = Glass
Shield
C = With shield
CC = Double shield

Dimensions [mm]

Inner Ø	Outer Ø	Width	Cage/ball material combination				Part No.			
			B180		F180	S180				
			PA/ES	PA/GL	B180/ES	PA/ES				
d1	d2	d3	b1	b2	PA/ES	PA/GL	B180/ES	PA/ES	PA/ES	
6.0	19.0	22.0	6.0	1.5	-	-	-	-	●	BB-626F-S180-10-ES-C
8.0	16.0	18.0	5.0	1.0	-	-	-	-	●	BB-688F-S180-10-ES-C
8.0	22.0	25.0	7.0	1.5	-	-	-	-	●	BB-608F-S180-10-ES-C
8.0	28.0	30.0	7.0	2.0	●	-	-	-	-	BB-608F2830-B180-10-ES
10.0	28.0	30.0	9.0	2.0	●	-	-	-	-	BB-6000F2830-B180-10-ES
10.0	35.0	38.0	9.0	2.0	●	-	-	-	-	BB-6000F3538-B180-10-ES
12.0	28.0	30.0	9.0	2.0	●	-	-	-	-	BB-6001F2830-B180-10-ES
12.0	35.0	38.0	9.0	2.0	●	-	-	-	-	BB-6001F3538-B180-10-ES
15.0	35.0	38.0	9.0	2.0	●	-	-	-	-	BB-6002F3538-B180-10-ES
17.0	35.0	38.0	10.0	2.0	●	-	-	-	-	BB-6003F3538-B180-10-ES
20.0	46.0	50.0	12.0	2.0	-	-	●	-	-	BB-6004F4650G-B180-30-ES
20.0	56.0	60.0	12.0	2.0	-	-	●	-	-	BB-6004F5660G-B180-30-ES
8.0	26.0	28.0	8.5	1.5	●	●	-	●	-	BB-608F-□-10-□-CC
8.0	26.0	28.0	7.0	1.5/1.0 (b3)	●	●	-	●	-	BB-608FF-□-10-□-CC



Available from stock



Aluminium tube with xirodur® B180 ball bearing

- Suitable for contact with food

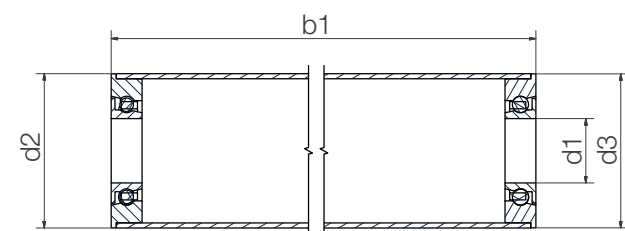

Order key

Type	Material
------	----------

BBT-AC 38-6000-B180-10-ES

Ball bearing guide roller	Aluminium tube	Outer Ø	Dimensions according to DIN 625-1	Race material	Cage material	Ball material
---------------------------	----------------	---------	-----------------------------------	---------------	---------------	---------------

- Radial deep groove ball bearings with flange also available as individual parts** ▶Page 910
- Cage material**
10 = PA
30 = xirodur® B180
- Ball material**
ES = Stainless steel

Dimensions [mm]

Inner Ø d1	Outer Ø d2	Flange Ø d3	Length b1	Part No.
6	20	19.9	50–500	BBT-AC20-606-B180-30-ES New
8	20	19.9	50–500	BBT-AC20-688-B180-30-ES New
8	30	29.9	50–1,500	BBT-AC30-608-B180-10-ES
10	30	29.9	50–1,500	BBT-AC30-6000-B180-10-ES
12	30	29.9	50–1,500	BBT-AC30-6001-B180-10-ES
10	38	37.9	50–1,500	BBT-AC38-6000-B180-10-ES
12	38	37.9	50–1,500	BBT-AC38-6001-B180-10-ES
15	38	37.9	50–1,500	BBT-AC38-6002-B180-10-ES
17	38	37.9	50–1,500	BBT-AC38-6003-B180-10-ES
20	50	49.9	50–1,500	BBT-AC50-6004-B180-30-ES
20	60	59.9	50–1,500	BBT-AC60-6004-B180-30-ES



Online configurator for xiros® system solutions
▶ www.igus.eu/xirosAlu



Order example:
BBT-AC38-6000-B180-10-ES, L=500mm = Aluminium tube with 2 ball bearings with race material xirodur® B180, PA cage and stainless steel balls, total length 500mm



Available from stock



PVC tube with xirodur® B180 ball bearing

- Components for use in food in accordance with 10/2011/EU and 1935/2004/EG

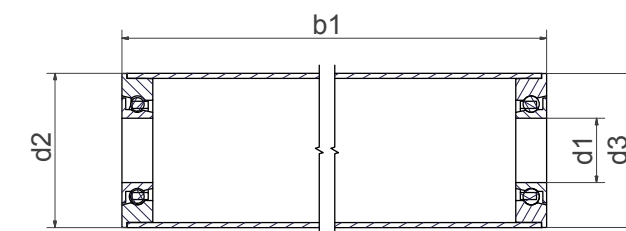

Order key

Type	Material
------	----------

BBT-PVC 50-6004-B180-30-ES

Ball bearing guide roller	PVC tube	Outer Ø	Dimensions according to DIN 625-1	Race material	Cage material	Ball material
---------------------------	----------	---------	-----------------------------------	---------------	---------------	---------------

- Cage material**
30 = xirodur® B180
- Ball material**
ES = Stainless steel

Dimensions [mm]

Inner Ø d1	Outer Ø d2	Flange Ø d3	Length b1	Part No.
8	30	30	50–1,000	BBT-PVC30-608-B180-30-ES
10	30	30	50–1,000	BBT-PVC30-6000-B180-30-ES
10	40	40	50–1,000	BBT-PVC40-6000-B180-30-ES
12	40	40	50–1,000	BBT-PVC40-6001-B180-30-ES
15	40	40	50–1,000	BBT-PVC40-6002-B180-30-ES
17	40	40	50–1,000	BBT-PVC40-6003-B180-30-ES
20	50	50	50–1,000	BBT-PVC50-6004-B180-30-ES
20	63	63	50–1,000	BBT-PVC63-6004-B180-30-ES



Order example:
BBT-PVC50-6004-B180-30-ES, L=200mm = PVC tube with 2 ball bearings with race material xirodur® B180, xirodur® B180 cage and stainless steel balls, total length 200mm



Available from stock

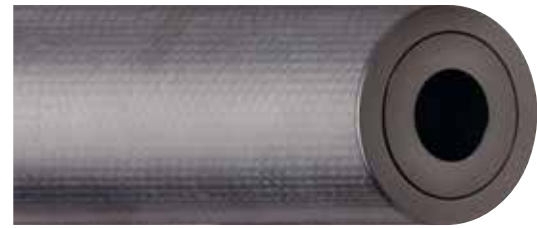

Carbon fibre tube with xirodur® S180 ball bearing, available as ESD version (with xirodur® F180 ball bearing)



Carbon fibre tube with xirodur® F180 ball bearing

Order key

Type Material

BBT-CF 50-6004-□-30-ES

Ball bearing guide roller	Carbon fibre tube	Outer Ø	Dimensions according to DIN 625-1	Race material	Cage material	Ball material
---------------------------	-------------------	---------	-----------------------------------	---------------	---------------	---------------

Cage material

30 = xirodur® B180

Ball material

ES = Stainless steel

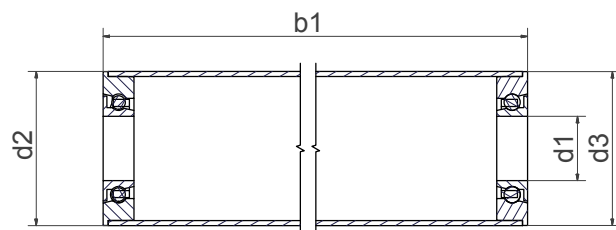

Dimensions [mm]

Inner Ø	Outer Ø	Flange Ø	Length	Part No.
d1	d2	d3	b1	
20	50	49.9	50–1,000	BBT-CF50-6004-S180-30-ES
20	100	100.0	50–1,000	BBT-CF100-6004-F180-30-ES



Order example:

BBT-CF50-6004-S180-30-ES, L=200mm = Carbon fibre tube with 2 ball bearings xirodur® S180, xirodur® B180 cage and stainless steel balls, total length 200mm



Delivery time: approximately 3 weeks

With xirodur® F180 as ESD version available upon request



Closed special solution with aluminium tube and polymer ball bearing for guide rollers and label rollers

Order key

Type Material

BBTG-AC 30-□-30-ES

Ball bearing guide roller	Aluminium tube	Outer Ø	Length – upon request	Cage material	Ball material
---------------------------	----------------	---------	-----------------------	---------------	---------------

Cage material

30 = xirodur® B180

Ball material

ES = Stainless steel



Ready-to-install complete systems with shaft to required size upon request

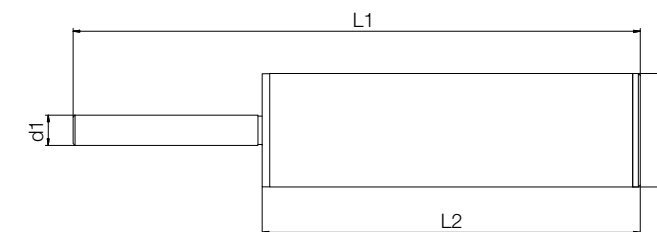

Dimensions [mm]

Outer Ø	Length	Part No.
d2	L1	
30	According to customer request	BBTG-AC30-XX-30-ES



Order example:

BBTG-AC30-200-30-ES, L=200mm = Aluminium with 2 ball bearings with race material xirodur® S180, xirodur® B180 cage and stainless steel balls, total length 200mm



Available

upon request



PA cage,
stainless steel or
glass balls



PA cage,
stainless steel balls
hexagon nut socket



Order key

Type Material

BB-6204EC44.5-B180-10-ES

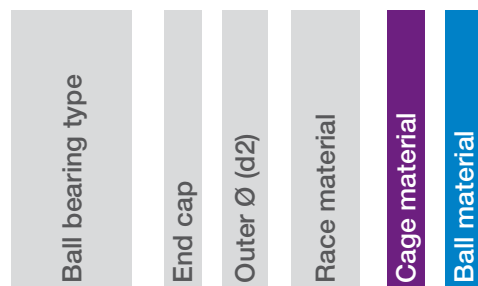

Cage material

10 = PA

Options:

Ball material

ES = Stainless steel

GL = Glass

Example "6204EC"

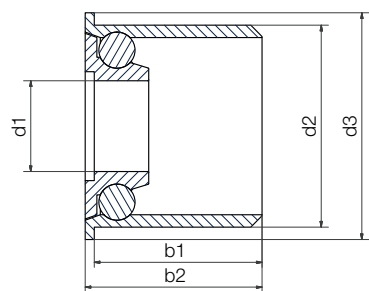

Example "6204ECM8"

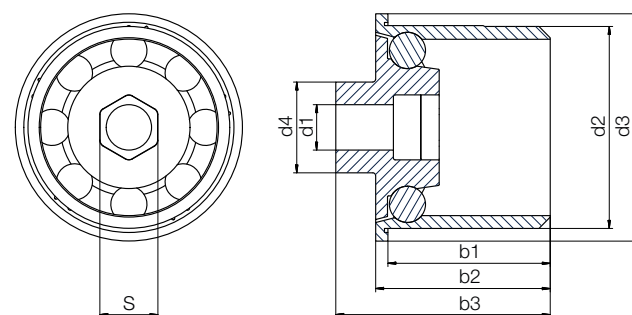

Technical data

Installation size	Radial load capacity		Max. speed [rpm]	Weight	
	stat. [N]	dyn. [N]		PA/ES [g]	PA/GL [g]
6204	245	294	1,800	41.66	29.85
6204	245	294	1,800	48.44	-

Dimensions [mm]

Inner Ø d1	Outer Ø d2 d3		Width d4 b1 b2 b3	S	Cage/ball material combination		Part No.
	PA/ES	PA/GL					
20	44.5	50	- 35.8 38.5 -	-	● ●	BB-6204EC44.5-B180-10-□	
10	44.5	50	20 35.8 38.5 47.3	M8	● -	BB-6204ECM8-B180-10-ES	



Order example:

BB-6204EC44.5-B180-10-ES = End cap with race material xirodur® B180, with PA cage and stainless steel balls



Available
from stock

My sketches

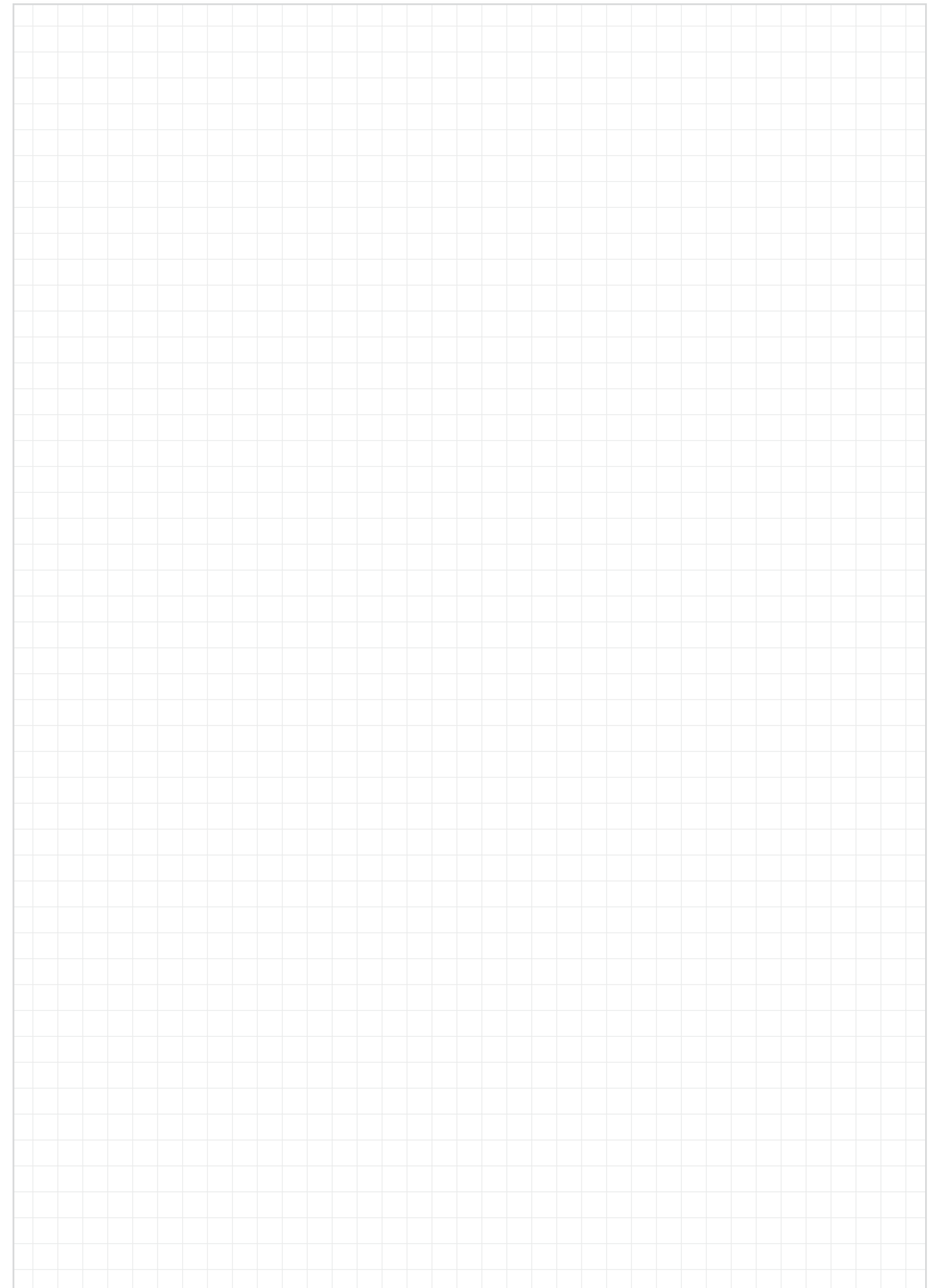



xirodur® B180 cage, stainless steel balls
Type 6000PP3



xirodur® B180 cage, stainless steel balls
Type 608P6

Order key

Type	Material	Design
------	----------	--------

BB-608 P6-B180-30-ES-C

Ball bearings	Dimensions according to DIN 625-1	Profile P6	Race material	Cage material	Ball material	With shield
				30 = xirodur® B180	ES = Stainless steel	C = Shield on one side

- One-piece design
- Replaces several components

Example "Profile PP3"

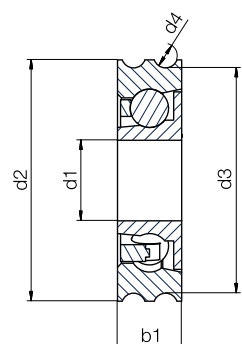

Example "Profile P8"

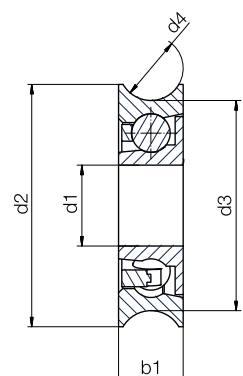

Technical data

Installation size	Radial load capacity		Max. speed [rpm]	Weight B180/ES [g]
	stat. [N]			
608P6	80		2,200	3.96
608P8	140		1,800	23.37
6000P8	110		2,200	7.14
6000PP3	110		2,200	7.86
6201P9	160		1,600	27.05

Dimensions [mm]

Inner Ø d1	Outer Ø d2	Base Ø d3	Groove Ø d4	Width b1	Part No.
8	24	20.5	6	7	BB-608P6-B180-30-ES-C
8	48	32	8	14	BB-608P8-B180-30-ES
10	30	26	8	8	BB-6000P8-B180-30-ES-C
10	30	28	3	8	BB-6000PP3-B180-30-ES-C
12	60	43.5	9	12	BB-6201P9-B180-30-ES



Order example:

BB-608P6-B180-30-ES = Radial deep groove ball bearing, profile P8 with race material xirodur® B180, xirodur® B180 cage and stainless steel balls



Available from stock



xirodur® B180 races PA cage, stainless steel balls



xirodur® B180 races PA cage, glass balls

Order key

Type	Material
------	----------

BB-608SO-B180-10-ES

Ball bearings	Dimensions according to DIN 625-1	Spherical outer Ø	Race material	Cage material	Ball material
				10 = PA	ES = Stainless steel

- Use in skewed/curved/twisted profiles
- Prevents edge stress

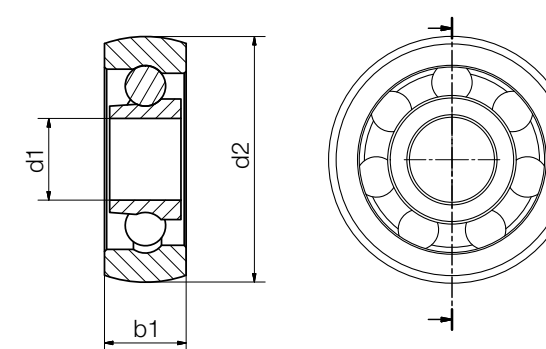

Race material
B180 = xirodur® B180
Cage material
10 = PA
Options:
Ball material
ES = Stainless steel
GL = Glass

Technical data

Installation size	Radial load capacity		Max. speed [rpm]	Weight	
	stat. [N]	dyn. [N]		PA/ES [g]	PA/GL [g]
608	80	94	2,200	4.63	3.34
6000	110	130	1,900	7.86	5.70
6001	138	147	1,750	13.51	11.10

Dimensions [mm]

Inner Ø d1	Outer Ø d2	Width b1	Width b2	Cage/ball material combination		Part No.
				PA/ES	PA/GL	
8	24.00	8	7	●	●	BB-608SO-B180-10- <input type="checkbox"/>
10	28.96	10	8	●	●	BB-6000SO-B180-10- <input type="checkbox"/>
12	35.56	12	8	●	●	BB-6001SO-B180-10- <input type="checkbox"/>



Order example:

BB-608SO-B180-10-ES = Ball bearing with spherical outer diameter, race material xirodur® B180, PA cage and stainless steel balls



Available from stock

Races made from xirodur® B180



PA cage,
stainless steel or
glass balls

- Higher loads
- More cost-effective than two comparable bearings

Order key

Type	Material	Design
------	----------	--------

BB-6000-B180-10-ES-D

Ball bearings	Dimensions according to DIN 625-1	Face material	Cage material	Ball material	Double row
---------------	-----------------------------------	---------------	---------------	---------------	------------

Cage material
10 = PA
Options:
Ball material
ES = Stainless steel
GL = Glass

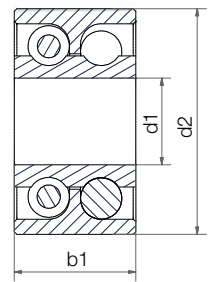

Technical data

Installation size	Radial load capacity		Max. speed [rpm]	Weight	
	stat. [N]	dyn. [N]		PA/ES [g]	PA/GL [g]
6000	200	240	1,000	11.23	6.90
6004	420	470	650	35.60	22.55

Dimensions [mm]

Inner Ø d1	Outer Ø d2	Width b1	Cage/ball material combination		Part No.
			PA/ES	PA/GL	
10	26	14	●	●	BB-6000-B180-10- -D
20	42	20	●	●	BB-6004-B180-10- -D

Order example:
BB-6000-B180-10-ES-D = double row ball bearing with race material xirodur® B180, PA cage and stainless steel balls

Available from stock

Races made from xirodur® B180



PP balls

- For rotary and linear motions

Order key

Type	Material
------	----------

BB-MB-1633-11-B180-PP

Ball bearings	Multi-axis bearing	Inner Ø (d1)	Outer Ø (d2)	Width (b)	Housing material	Ball material
---------------	--------------------	--------------	--------------	-----------	------------------	---------------

Housing material
B180 = xirodur® B180
Ball material
PP = Polypropylene

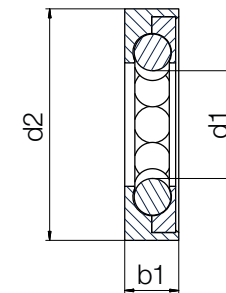

Technical data

Type	Radial load capacity		Max. speed [rpm]	Weight B180/PP [g]
	stat. [N]	dyn. [N]		
BB-MB	55	70	500	6.86

Dimensions [mm]

Inner Ø d1	Outer Ø d2	Width b1	Part No.
16.3	33	11	BB-MB-1633-11-B180-PP

Order example:
BB-MB-1633-11-B180-PP = Multi-axis bearing with race material xirodur® B180, B180 housing and PP balls

Available from stock

PA cage,
stainless steel ballsPA cage,
glass balls

- Larger outer diameter for smaller shafts
- Also used as roller in profiles

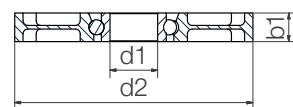

Order key

Type	Material
------	----------

BB-6004SW100-B180-10-ES

Ball bearings	Dimensions according to DIN 625-1	Skate wheel	Outer Ø	Race material	Cage material	Ball material
---------------	-----------------------------------	-------------	---------	---------------	---------------	---------------

Cage material

10 = PA

Options:

Ball material

ES = Stainless steel

GL = Glass

Technical data

Installation size	Radial load capacity		Max. speed [rpm]	Weight	
	stat. [N]	dyn. [N]		PA/ES [g]	PA/GL [g]
6004	245	294	1,400	58.81	58.81

Dimensions [mm]

Inner Ø d1	Outer Ø d2	Width b1	Part No.
20	100	12	BB-6004SW100-B180-10-



Order example:

BB-6004SW100-B180-10-ES = xiros® skate wheel with race material xirodur® B180. 100mm outer diameter, PA cage and stainless steel balls

Available
from stock

FDA

xirodur® B180 cage
Stainless steel balls

- For less precise holding fixtures

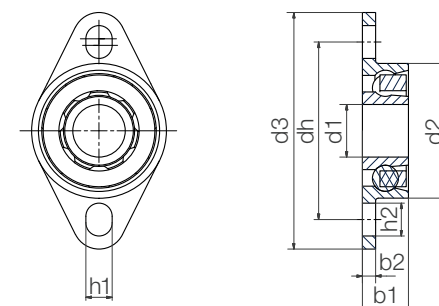

Order key

Type	Material
------	----------

BB-FL-608-B180-30-ES

Ball bearings	Fixed flange ball bearing	Dimensions according to DIN 625-1	Housing material	Cage material	Ball material
---------------	---------------------------	-----------------------------------	------------------	---------------	---------------

Cage material

30 = xirodur® B180

Ball material

ES = Stainless steel

Technical data

Installation size	Radial load capacity		Max. speed [rpm]	Weight B180/ES [g]
	stat. [N]	dyn. [N]		
626	60	62	3,200	2.89
608	80	92	2,200	3.65
6000	110	130	2,200	6.49
6001	130	147	2,000	7.68
6003	160	220	1,600	11.13
6004	250	320	1,400	25.06

Dimensions [mm]

d1	d2	d3	b1	b2	dh	h1	h2	Part No.
6	19	33.5	6	2	25	3	4.5	BB-FL-626-B180-30-ES
8	20.7	35.8	7	2	26.8	4	5	BB-FL-608-B180-30-ES
10	26	41	8	2	32	4	5	BB-FL-6000-B180-30-ES
12	28	44	8	2	35	4	5	BB-FL-6001-B180-30-ES
17	35	54	10	2.5	44	4	6	BB-FL-6003-B180-30-ES
20	42	84	12	4	63	8	12	BB-FL-6004-B180-30-ES



Order example:

BB-FL-608-B180-30-ES = Fixed flange ball bearing with xirodur® B180 housing, xirodur® B180 cage and stainless steel balls

Available
from stock



Type Material

BB-522B-B180-POM

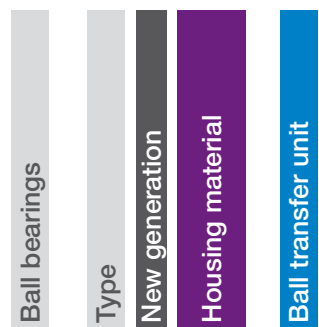

Polymer ball transfer unit
 POM = POM (ball transfer unit)
 Option
 B = New generation

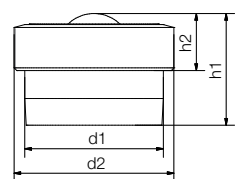

BB-505(B)-B180-POM

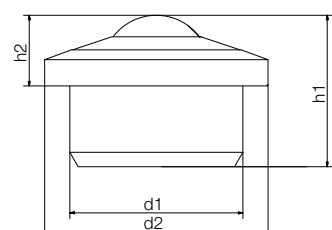

BB-515(B)-B180-POM
 BB-522(B)-B180-POM

Technical data and dimensions [mm]

Installation size	Max. stat. load capacity axial [N]	Inner Ø		Height		Weight [g]	Part No.
		d1	d2	h1	h2		
505	35	10.4	12.0	8.4	4.3	0.88	BB-505-B180-POM
515	80	24.0	31.0	21.0	9.8	10.73	BB-515-B180-POM
522	110	36.0	45.0	30.0	9.8	28.80	BB-522-B180-POM

Technical data and dimensions [mm]

Installation size	Max. stat. load capacity axial [N]	Inner Ø		Height		Weight [g]	Part No.
		d1	d2	h1	h2		
505B	150	10.4	12.0	8.4	4.3	0.92	BB-505B-B180-POM
515B	300	24.0	31.0	21.0	9.8	11.19	BB-515B-B180-POM
522B	500	36.0	45.0	30.0	9.8	29.97	BB-522B-B180-POM
530B	1000	45.0	55.0	37.0	13.8	67.40	BB-530B-B180-POM New

i Recommended tolerances

We recommend the following hole tolerances for the ball transfer units housings:

Installation size

- 505 ▶ 10.40mm H7
- 515/515A ▶ 24mm H7
- 522/522A ▶ 36mm H7

In general: The height tolerance of all installation sizes is ± 0.2mm

🛒 Order example:

BB-505-B180-POM = Polymer ball transfer unit with housing material xirodur® B180 and POM ball transfer unit

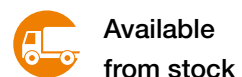

Available from stock



Type Material

BB-522B-ES

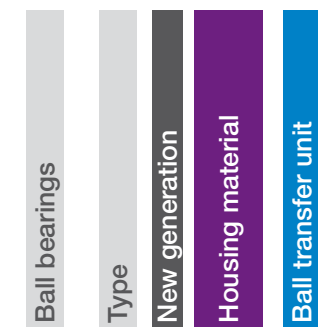

Ball transfer unit
 ES =
 Stainless steel

With stainless steel balls

Electrostatically dissipative

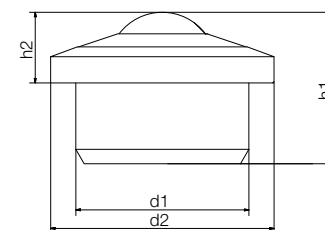

Technical data and dimensions [mm]

Installation size	Max. stat. load capacity axial [N]	Inner Ø		Height		Weight stainless steel [g]	Part No.
		d1	d2	h1	h2		
515	300	24.0	31.0	21.0	9.8	22.8	BB-515B-B180-ES
515	300	24.0	31.0	21.0	9.8	22.8	BB-515B-F182-ES
522	500	36.0	45.0	30.0	9.8	66.6	BB-522B-B180-ES

Technical data and dimensions [mm]

Installation size	Max. stat. load capacity axial [N]	Inner Ø		Height		Weight [g]	Part No.
		d1	d2	h1	h2		
515B	300	24.0	31.0	21.0	9.8	11.19	BB-515B-B180-ES
522B	500	36.0	45.0	30.0	9.8	29.97	BB-522B-B180-ES

i Recommended tolerances

We recommend the following hole tolerances for the ball transfer units housings:

Installation size

- 515/515A ▶ 24mm H7
- 522/522A ▶ 36mm H7

In general: The height tolerance of all installation sizes is ± 0,2mm

🛒 Order example:

BB-515-B180-ES = Polymer ball transfer unit with housing material xirodur® B180 and stainless steel ball transfer unit



Available from stock

Axial polymer ball transfer unit made from xirodur® B180



For high loads (HH)



With soft roller made from xirodur® D180 (HS)

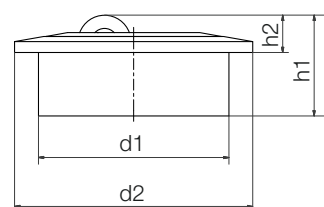

Order key

Type	Material
------	----------

BB-522A-B180-HS

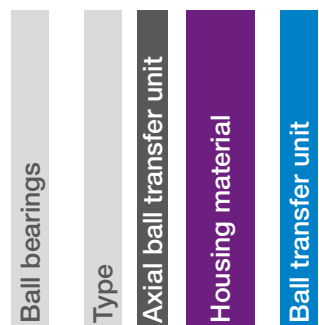

Options

- Ball transfer unit
- HH (Hard roller) = xirodur® B180
- HS (Soft roller) = xirodur® D180

- BB-515A-B180-HH/-HS
- BB-522A-B180-HH/-HS

Technical data and dimensions [mm]

Installation size	Max. stat. load capacity axial [N]	Inner Ø		Height		Weight		Part No.
		d1	d2	h1	h2	HS [g]	HH [g]	
515A	150	24.0	31.0	14.3	5.3	9.96	9.99	BB-515A-B180- <input type="checkbox"/>
522A	300	36.0	45.0	19.2	7.05	24.69	24.71	BB-522A-B180- <input type="checkbox"/>



Order example:

BB-515A-B180-HS = Axial polymer ball transfer unit with housing material xirodur® B180 and soft roller made from xirodur® D180



Available from stock

Accessories: Clamping rings for xiros® polymer ball transfer units

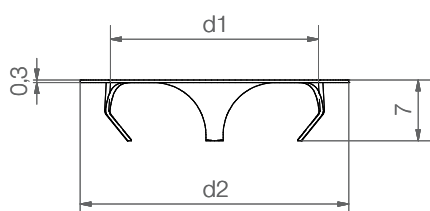

xiros® clamping rings made of stainless steel offer the possibility to install xiros® polymer ball transfer units in another orientation than the standard horizontal position. Easy assembly and disassembly.

Dimensions [mm]

For ball transfer unit	d1	d2	Housing hole	Weight [g]	Part No.
BB-515-B180-POM/BB-515A-B180- <input type="checkbox"/>	24	31	25H7	0.91	BB-515-CR
BB-522-B180-POM/BB-522A-B180- <input type="checkbox"/>	36	41	37H7	1.61	BB-522-CR



Available from stock

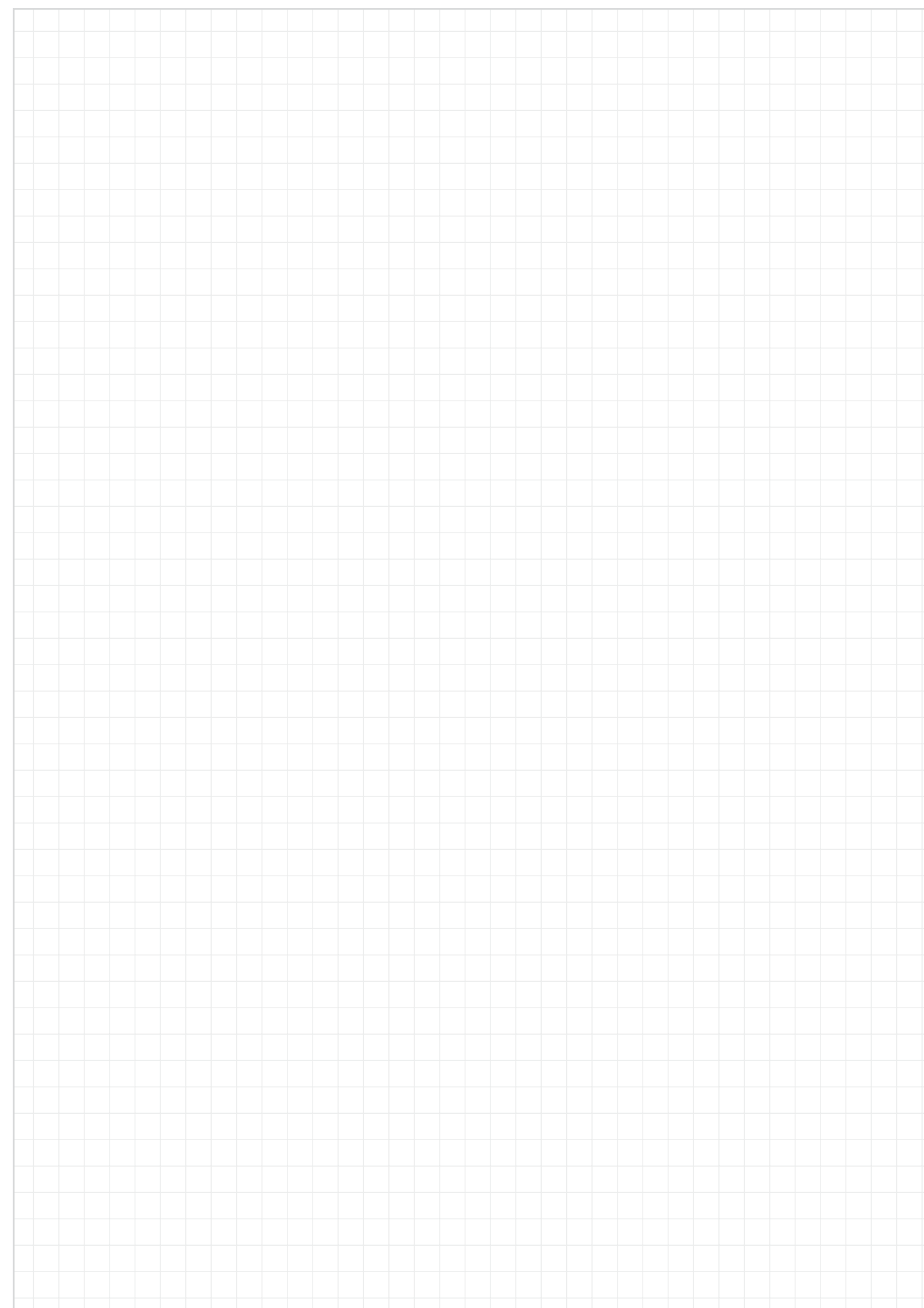



Order key

Type	Material
------	----------

BB-51104-B180-ES-D

Ball bearings	Dimensions according to DIN 711	Face/cage material	Ball material	Double row
---------------	---------------------------------	--------------------	---------------	------------

Options
Ball material
 ES = Stainless steel
 GL = Glass
Suffix
 Blank = Single row
 D = Double row

Single or double row,
with stainless steel or glass balls

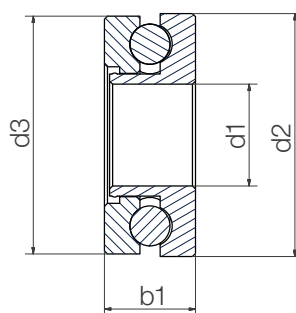

Single row bearing

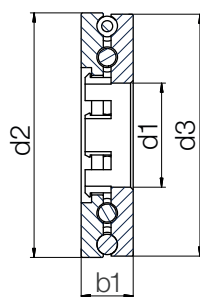

Double row bearing

Technical data

Installation size	Single row	Double row	Load capacity		Max. speed [rpm]	Weight	
			stat. [N]	dyn. [N]		B180/ES [g]	B180/GL [g]
51100	●	-	200	250	600	6.61	4.12
51104	●	-	650	810	460	13.72	8.19
51104	-	●	975	1,215	460	18.96	8.99

Dimensions [mm]

Inner Ø	Outer Ø		Width	Cage/ball material combination		Part No.
	d1	d2		B180/ES	B180/GL	
10	24	23.5	9	●	●	BB-51100-B180-□
20	35	34.5	10	●	●	BB-51104-B180-□
20	47	46.5	10	●	●	BB-51104-B180-□-D

Order example:

BB-51100-B180-ES = Thrust bearing with race material xirodur® B180, B180 cage and stainless steel balls



Available from stock



Standard type with stainless steel or glass balls



Slim Line design with stainless steel or glass balls

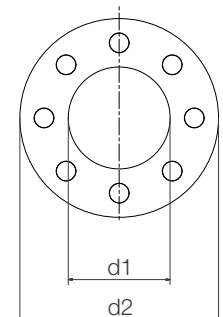

Order key

Type	Material
------	----------

BB-6004TW-B180-ES-SL

Ball bearings	Dimensions according to DIN 625-1	Axial thrust washer	Face material	Ball material	Slim Line
---------------	-----------------------------------	---------------------	---------------	---------------	-----------

Options
Ball material
 ES = Stainless steel
 GL = Glass
Suffix
 Blank = Standard
 SL = Slim Line

Technical data (related to metallic shafts)

Installation size	Slim Line	Recommended load capacity		Max. speed [rpm]	Weight	
		stat. [N]	dyn. [N]		B180/ES [g]	B180/GL [g]
626	-	341	425	2,000	1.35	0.81
608	-	482	600	1,700	2.25	1.17
6000	-	610	782	1,500	3.04	1.50
6000	●	405	500	1,500	2.09	1.20
6004	-	975	1,215	700	6.87	4.41
6006	-	925	1,540	600	5.51	3.39
6006	●	520	680	600	4.23	2.98

Dimensions [mm]

Inner Ø	Outer Ø		Width		Race/ball material combination		Part No.
	d1	d2	b1	b2	B180/ES	B180/GL	
6.2	18.8	2.0	3.18	●	●	BB-626TW-B180-□	
8.2	21.8	2.0	3.97	●	●	BB-608TW-B180-□	
10.2	25.8	2.0	4.76	●	●	BB-6000TW-B180-□	
10.2	25.8	2.0	3.97	●	●	BB-6000TW-B180-□-SL	
21.0	41.0	3.0	4.76	●	●	BB-6004TW-B180-□	
29.9	45.5	2.5	4.76	●	●	BB-6006TW-B180-□	
29.9	45.5	2.5	3.97	●	●	BB-6006TW-B180-□-SL	

Order example:

BB-6000TW-B180-ES-SL = Thrust washer with race material xirodur® B180, stainless steel balls, Slim Line version



Available from stock

xiros® slewing ring ball bearings | Product range

xirodur® B180 – for absorbing higher axial loads



Stainless steel balls

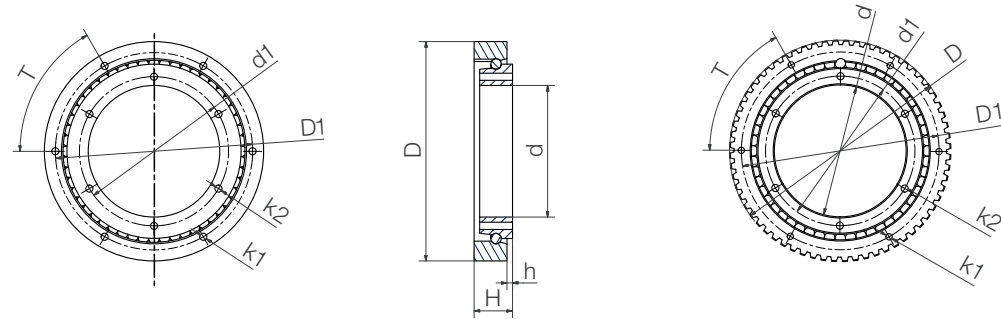

Glass balls

Stainless steel balls,
with cage made from
xirodur® B180Stainless steel balls,
with outer drive ring (HDT5)

Technical data

Type	Load capacity		Max. permissible moment [Nm]	Max. speed [rpm]	Weight	
	Axial [N]	Radial [N]			ES [g]	glass [g]
Standard with stainless steel or glass balls						
RT-01-60	800	720	40	350	111.68	98.3
RT-01-100	1,600	1,250	60	250	283.85	243.76
Slewing ring ball bearings with xirodur® B180 cage						
RT-01-40-B180-30	500	260	30	900	63.46	–
RT-01-60-B180-30	600	300	30	800	101.22	–
RT-01-100-B180-30	1,020	760	55	650	248.90	–
RT-01-150-B180-30	2,000	1,100	75	600	398.00	–
RT-01-400-B180-30	5,800	2,900	170	500	–	6338
Slewing ring ball bearings with outer drive ring						
RT-01-60HDT5-B180-30	800	720	40	320	97.00	–



Order example:

BB-RT-01-60-ES = Standard slewing ring ball bearing with race material xirodur® B180 and [stainless steel balls](#)

BB-RT-01-60-B180-30-ES = Slewing ring ball bearing with race material xirodur® B180, [xirodur® B180 cage](#) and stainless steel balls

BB-RT-01-60-HDT5-B180-ES = Slewing ring ball bearing with race material xirodur® B180, outer drive ring and stainless steel balls

BB-RT-01-60-HDT5-B180-30-ES = Slewing ring ball bearing with race material xirodur® B180, outer drive ring, [xirodur® B180 cage](#) and stainless steel balls



Order key

Type	Design	Material
------	--------	----------

BB-RT-01-60-ES

Ball bearings	Slewing ring ball bearings	Type 01	Inner Ø	Ball material
---------------	----------------------------	---------	---------	---------------

Options

Ball material

ES = Stainless steel

GL = Glass



Order key with cage

Type	Design	Material
------	--------	----------

BB-RT-01-60-B180-30-ES

Ball bearings	Slewing ring ball bearings	Type 01	Inner Ø	Race material	Cage material	Ball material
---------------	----------------------------	---------	---------	---------------	---------------	---------------

Dimensions [mm]

d	d1	D	D1	h	H	T	k1	k2	Part No.
Standard with stainless steel or glass balls									
60	68	100	90	2.5	17.5	60	3.3	3.3	BB-RT-01-60- <input type="text"/>
100	110	160	150	5.0	20.0	60	5.2	5.2	BB-RT-01-100- <input type="text"/>
Slewing ring ball bearings with xirodur® B180 cage									
40	47	80	72	2.5	15	60	3.3	3.3	BB-RT-01-40-B180-30-ES
60	68	100	90	2.5	17.5	60	3.3	3.3	BB-RT-01-60-B180-30-ES
100	110	160	150	5.0	20	60	5.2	5.2	BB-RT-01-100-B180-30-ES
150	163	210	197	5.0	20	60	6.1	6.1	BB-RT-01-150-B180-30-ES
400	450	600	550	10.0	40	51.43	8.0	8.0	BB-RT-01-400-B180-30-GL
Slewing ring ball bearings with outer drive ring									
60	68	100	90	2.5	17.5	60	M3	3.3	BB-RT-01-60HDT5-B180-30-ES



Available
from stock



Type Material

ESTM-BB1-F25-B180-ES-SL

Pillow block bearing	Ball bearing, single row	Fixed version	Inner Ø	Race/cage material	Ball material	Slim Line
----------------------	--------------------------	---------------	---------	--------------------	---------------	-----------

Race/cage material
 B180 = xirodur® B180
Ball material
 ES = Stainless steel

- FDA-compliant components
- Can withstand loads of up to approximately 50kg (depending on installation size)

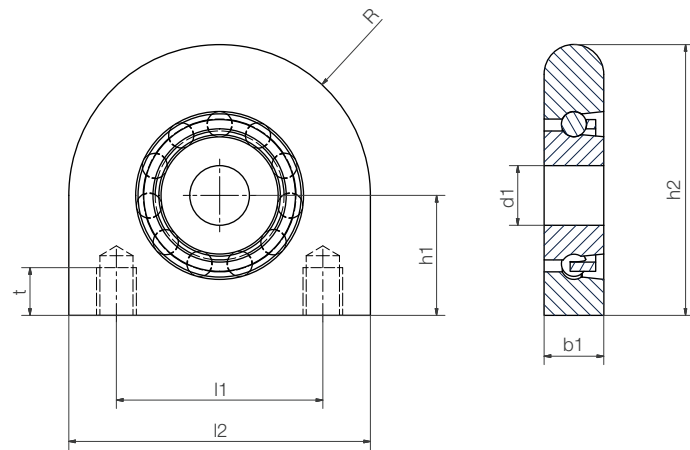

Technical data

Type	Load capacity, radial		Max. speed [rpm]	Weight ES [g]
	stat. [N]	dyn. [N]		
ESTM-F15	270	350	1,250	86
ESTM-F17	280	360	1,200	85
ESTM-F20	290	370	1,150	83
ESTM-F25	480	520	850	119
ESTM-F30	500	550	840	163

Technical data

d1	b1	h1	h2	l1	l2	R	Thread	t	Part No.
15	15	30.2	68.2	52	76	38	M10	12	ESTM-BB1-F15-B180-ES-SL
17	15	30.2	68.2	52	76	38	M10	12	ESTM-BB1-F17-B180-ES-SL
20	15	30.2	68.2	52	76	38	M10	12	ESTM-BB1-F20-B180-ES-SL
25	17	36.5	78.5	56	84	42	M10	15	ESTM-BB1-F25-B180-ES-SL
30	19	42.9	89.9	66	94	47	M14	18	ESTM-BB1-F30-B180-ES-SL

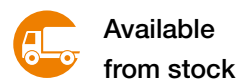

Available from stock

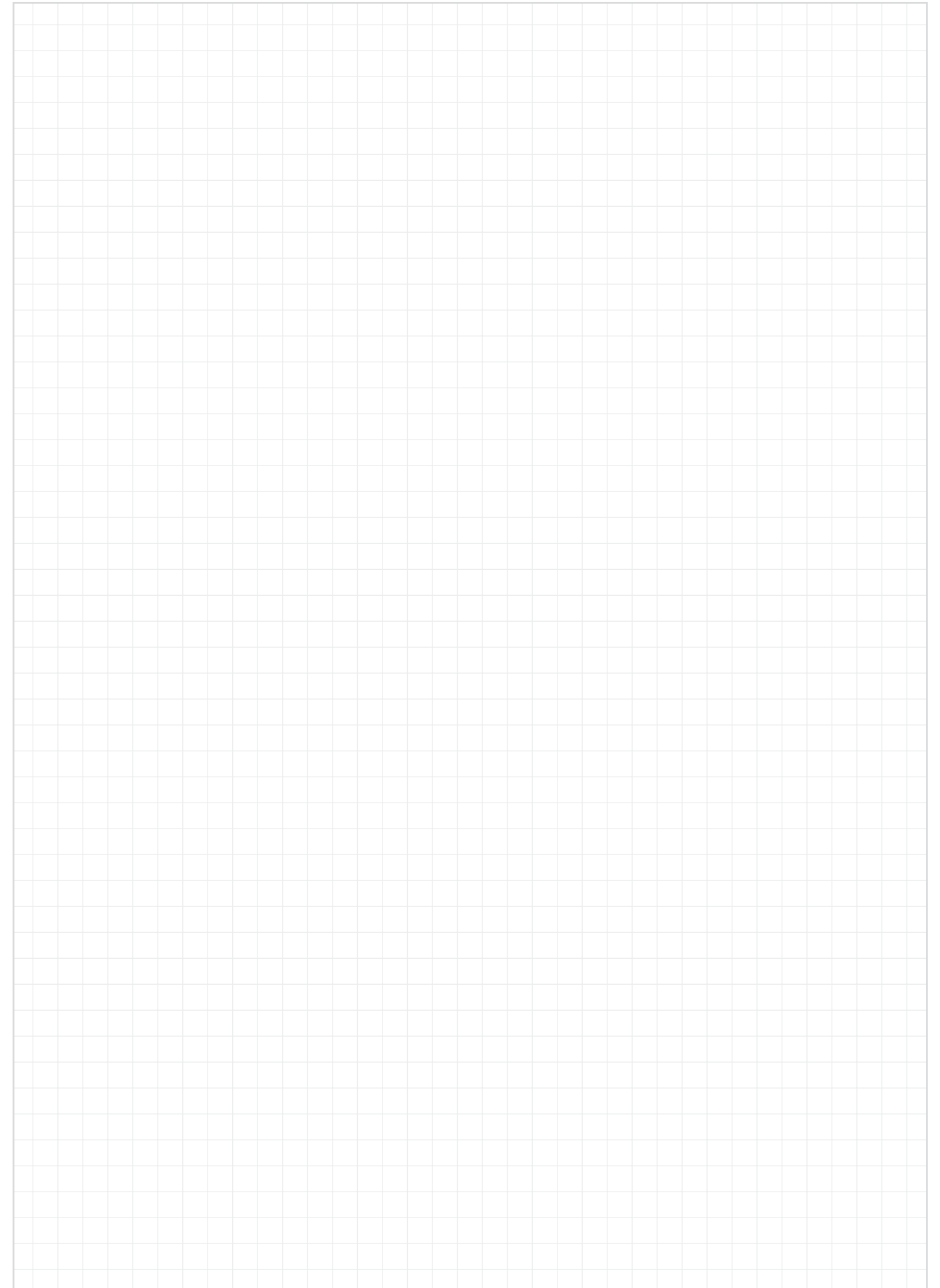

Fixed version



igumid G housing, PA cage, stainless steel balls

igumid G housing, PA cage, glass balls

- Assembly-friendly

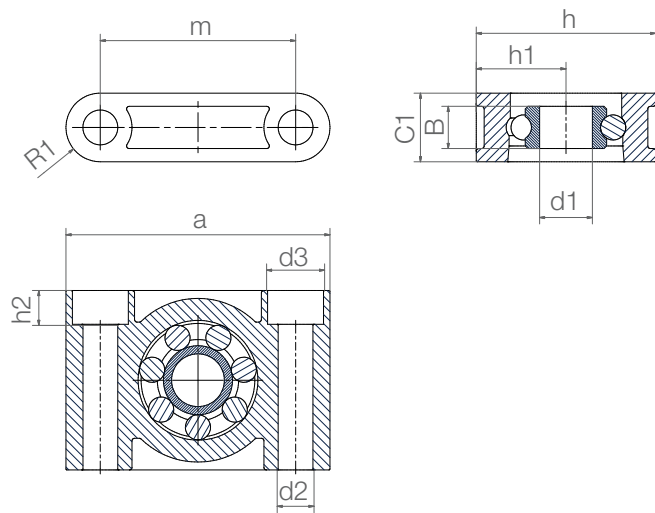

Order key

Type	Material
ESTM-BB1-F06-B180-ES	
Pillow block bearing	
Ball bearing, single row	
Fixed version	
Inner Ø	
Race material	
Ball material	

Race material
B180 = xirodur® B180
 Options:
 Ball material
ES = Stainless steel
GL = Glass

Technical data

Type	Radial load capacity		Max. speed [rpm]	Weight	
	stat. [N]	dyn. [N]		B180/ES [g]	B180/GL [g]
ESTM-F06	41	43	2,600	7.7	6.7
ESTM-F10	110	130	1,900	20.2	18.2
ESTM-F20	250	320	1,150	54.1	47.7

Dimensions [mm]

Inner Ø d1	Hole Ø d2	d3	h	h1	h2	a	m	C1	B	R1	Part No.
6	5.5	-	22	11	-	36	26	10	6	5.0	ESTM-BB1-F06-B180-□
10	6.6	10.6	34	17	6.6	50	37	13	8	6.5	ESTM-BB1-F10-B180-□
20	9.0	14.0	48	24	8.6	72	54	18	12	9.0	ESTM-BB1-F20-B180-□

Order example:
 ESTM-BB1-F06-B180-ES = Pillow block bearing, fixed version, made from xirodur® B180 with stainless steel balls

Available from stock

Pivoting version



igumid G housing, PA cage, stainless steel balls

igumid G housing, PA cage, Glass balls

- Compensation of misalignment errors

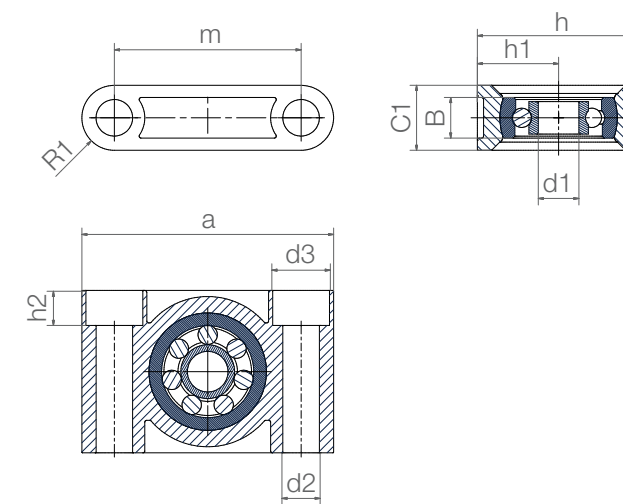

Order key

Type	Material
ESTM-BB1-P 08-B180-ES	
Pillow block bearing	
Ball bearing, single row	
Pivoting version	
Inner Ø	
Race material	
Ball material	

Race material
B180 = xirodur® B180
 Options:
 Ball material
ES = Stainless steel
GL = Glass

Technical data

Type	Radial load capacity		Max. speed [rpm]	Weight	
	stat. [N]	dyn. [N]		B180/ES [g]	B180/GL [g]
ESTM-P08	80	94	2,200	19.6	18.2
ESTM-P10	110	130	1,900	32.9	30.3
ESTM-P12	130	147	1,750	54.8	52.8

Dimensions [mm]

Inner Ø d1	Hole Ø d2	d3	h	h1	h2	a	m	C1	B	R1	Max. pivot angle	Part No.
8	6.6	10.6	34	17	6.4	50	37	13	8	6.5	±5°	ESTM-BB1-P08-B180-□
10	9.0	14.0	40	20	8.6	62	46	16	10	8	±5°	ESTM-BB1-P10-B180-□
12	9.0	14.0	48	24	8.6	72	54	18	12	9	±5°	ESTM-BB1-P12-B180-□

Order example:
 ESTM-BB1-P08-B180-ES = Pillow block bearing, pivoting version, made from xirodur® B180 with stainless steel balls

Available from stock



igumid G housing,
PA cage,
stainless steel balls or
glass balls

- Compensation of misalignment errors

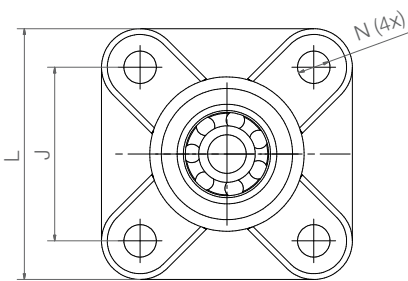
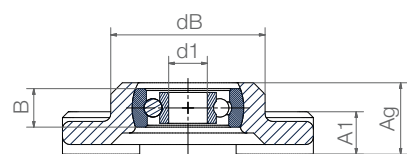

Order key

Type	Material
------	----------

EFSM-BB1-P 08-B180-ES

4-hole fixed flange ball bearings	Ball bearing, single row	Pivoting version	Inner Ø	Face material	Ball material
-----------------------------------	--------------------------	------------------	---------	---------------	---------------

Race material

B180 = xirodur® B180

Options:

Ball material

ES = Stainless steel

GL = Glass

Technical data

Type	Radial load capacity		Max. speed [rpm]	Weight	
	stat. [N]	dyn. [N]		B180/ES [g]	B180/GL [g]
EFSM-P08	80	94	2,200	25.2	24.0
EFSM-P10	110	130	1,900	48.8	46.2
EFSM-P12	130	147	1,750	80.0	77.7

Dimensions [mm]

Inner Ø d1	dB d2	L	J	A1	Ag	B	N	Max. pivot angle	Part No.
8	32.5	52	36	9	15.5	8	6.4	±20°	EFSM-BB1-P08-B180- <input type="checkbox"/>
10	40.0	65	45	11	18.8	10	8.4	±20°	EFSM-BB1-P10-B180- <input type="checkbox"/>
12	48.0	74	52	14	23.5	12	8.4	±20°	EFSM-BB1-P12-B180- <input type="checkbox"/>



Order example:

EFSM-BB1-P08-B180-ES = 4-hole fixed flange ball bearing with race material xirodur® B180 and stainless steel balls

Available
from stock

igumid G housing,
PA cage,
stainless steel balls or
glass balls

- Trouble-free readjustment thanks to elongated holes
- Precise alignment of the bearings not necessary

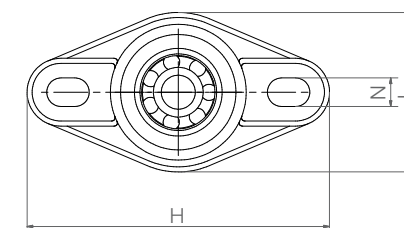
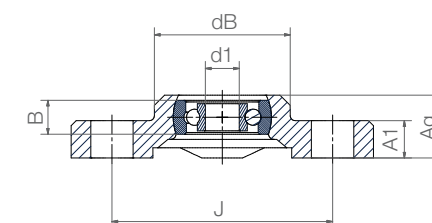

Order key

Type	Material
------	----------

EFOM-BB1-P 08-B180-ES

2-hole fixed flange ball bearings	Ball bearing, single row	Pivoting version	Inner Ø	Face material	Ball material
-----------------------------------	--------------------------	------------------	---------	---------------	---------------

Race material

B180 = xirodur® B180

Options:

Ball material

ES = Stainless steel

GL = Glass

Technical data

Type	Radial load capacity		Max. speed [rpm]	Weight	
	stat. [N]	dyn. [N]		B180/ES [g]	B180/GL [g]
EFOM-P08	80	94	2,200	19.5	18.1
EFOM-P10	110	130	1,900	36.3	33.6
EFOM-P12	130	147	1,750	61.7	59.4

Dimensions [mm]

Inner Ø d1	dB d2	H	L	J	A1	Ag	B	N	Max. pivot angle	Part No.
8	32.5	72.6	38	53	10	15.5	8	6.4x10.1	±20°	EFOM-BB1-P08-B180- <input type="checkbox"/>
10	40.0	89.0	47	65	11	18.8	10	8.4x12.5	±20°	EFOM-BB1-P10-B180- <input type="checkbox"/>
12	48.5	101.0	58.5	75	14	23.5	12	8.4x12.5	±20°	EFOM-BB1-P12-B180- <input type="checkbox"/>



Order example:

EFOM-BB1-P08-B180-ES = 2-hole fixed flange ball bearing with race material xirodur® B180 and stainless steel balls

Available
from stock



Infinite possibilities

Customised & cost-effective: your polymer ball bearing in the required design, material and quantity.

- Machined or injection-moulded
- Square or round
- With flange, outer toothed profile, etc.
- In customised quantity
- Lubrication and maintenance-free
- Cost-effective
- Select from different xirodur® materials

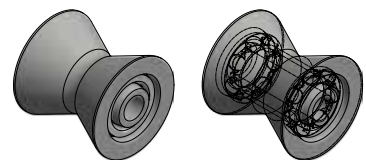

Guide roller for rubber seals in car production: which replaced a special unavailable roller

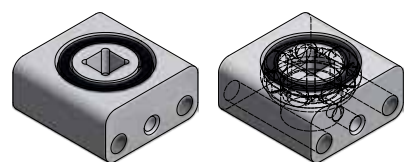

Non-magnetic for drylin® linear guide: design of a ball bearing with square housing, square shaft and glass balls

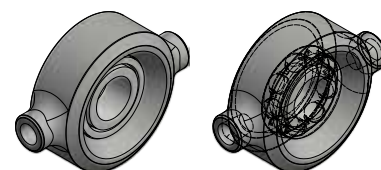

Consumer product camera stabilizer: injection-moulded special parts to improve engineered solution

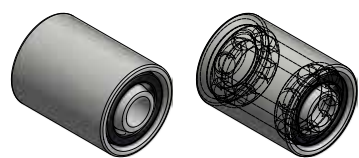

Blood pumps (peristaltic): lubrication-free and longer service life

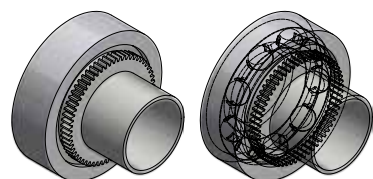

Gear-driven shaft: one-part solution for full integration

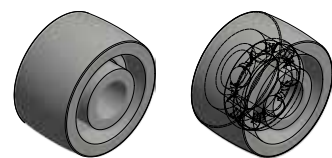

Roller for belt guide in ATM cash machines

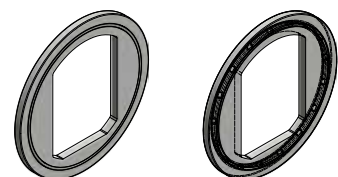

Tension rollers in rubber production

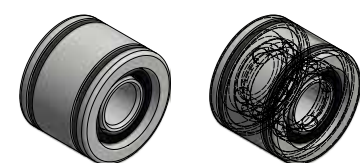

Bearings for cash machines: lubrication-free and integration of 2 rubber rings for better paper grip

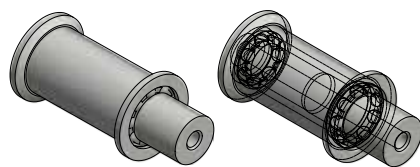

Tension roller for tape deflection: one-part solution (6 in 1)

In 3 steps to your individual ball bearing

1. Submit an enquiry

Fill in the form with some basic information: quantity and requirement, such as food contact, dirt resistance, etc. and upload the CAD files, for example.

After one of our specialists has contacted you for a consultation, you will receive a quotation.

2. We manufacture your required component

Upon order, igus® starts the production process.

3. You receive your product

Your required component is ready to ship and delivered quickly.

Submit an enquiry:

► www.igus.eu/xiros-specialparts

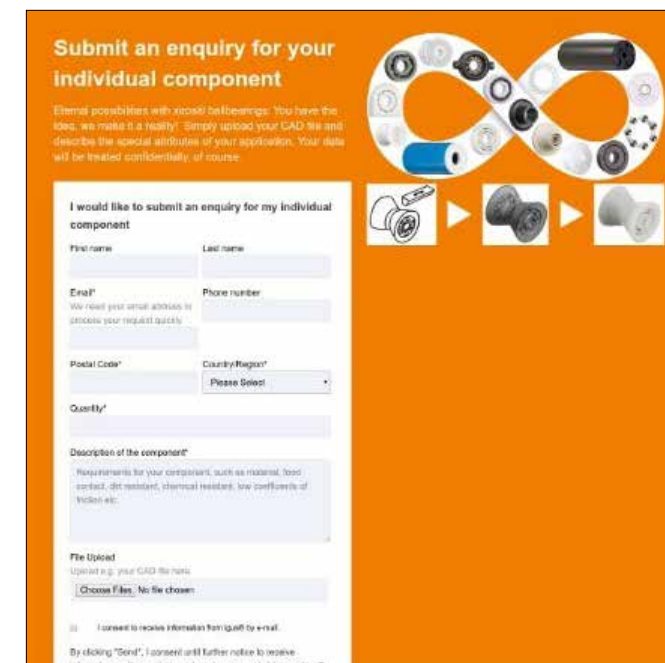

igus® test lab

The material combinations included in xiros® ball bearings are subjected to a large number of load and speed tests in the igus® test laboratory. The test results can be used to determine service life and suitability for both standard and special parts.



