

Lumiglas Double Glass Safety Sight Glass Fitting

also available with inter glass heating

A pair of circular recessed flanges housing twin glass discs four seals and a supporting spacer ring, for bolting onto weld neck nozzle flanges, weld pads etc.

The exploded view below shows how the glass disc, their respective seals and the spacer ring are sandwiched and mechanically compressed into a single entity by socket head bolts.

- **Connecting sizes: PN 10/16**

The design of the supporting spacer ring ensures that each of the two glasses discs is able to withstand the maximum rated operating pressure and max. permissible temperature independently of the other.

- **Application:**

For viewing of internals of pressure vessels, silos, stirred vessels, separators, pipelines and other normally enclosed systems. Continuous monitoring for leakage is possible with externally fitted pressure gauge.

- **Operating conditions:**

Pressure: 10 bar (higher pressure ratings on request)
 Temperatures: 280°C with toughened borosilicate glass to DIN 7080
 150°C with toughened Sodalime to DIN 8902 (higher temperatures on request)

- **Combinations:**

These units can be combined with Lumiglas luminaires for use in Ex hazardous as well as non hazardous areas. The mating flange can be drilled and tapped to suit the luminaire mounting brackets.

- **Parts and material alternatives**

the adjoining diagram shows:

Item	Part	Material
1	Base flange	Steel S235JR+N (RSt 37-2) Stainless steel 1.4571 or other
2.1+2.2	Seal	KLINGERSil C-4400, Silicon, PTFE or other
3	Sight glass-discs	Sodalime glass DIN 8902, Borosilicate DIN 7080
4	Spacer support ring	Steel S235JR+N (RSt 37-2), Stainless steel 1.4571 or other
5	Mating flange	Steel S235JR+N (RSt 37-2), Stainless steel 1.4571 or other
6	Compression bolts	DIN 912



Lumiglas double glass safety sight glass fitting

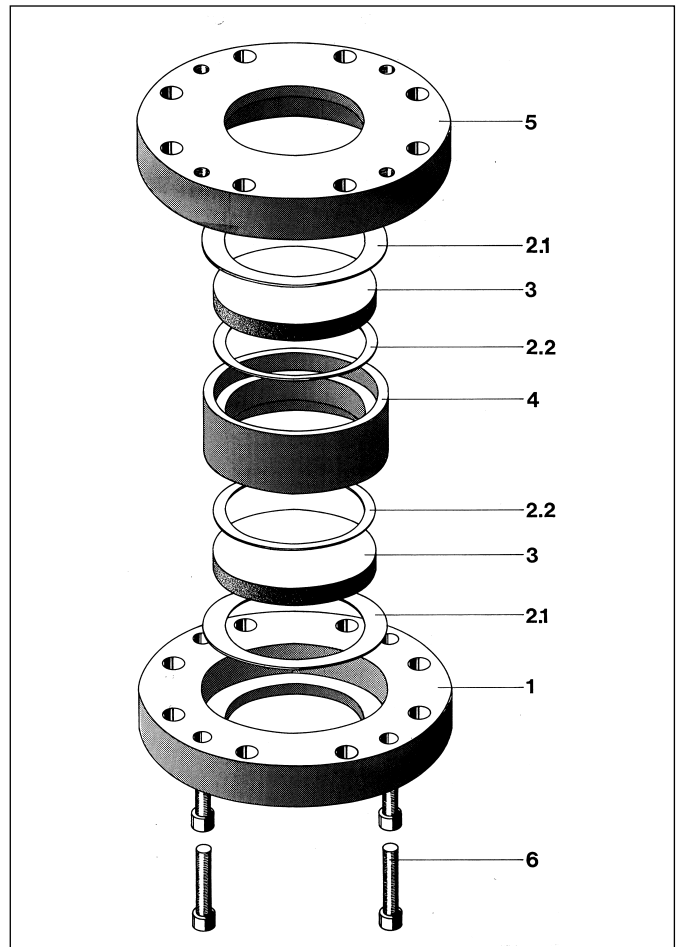

Exploded view of a Lumiglas double glass safety sight glass fitting

• **Dimensions of Lumiglas double glass safety sight glass fitting:**

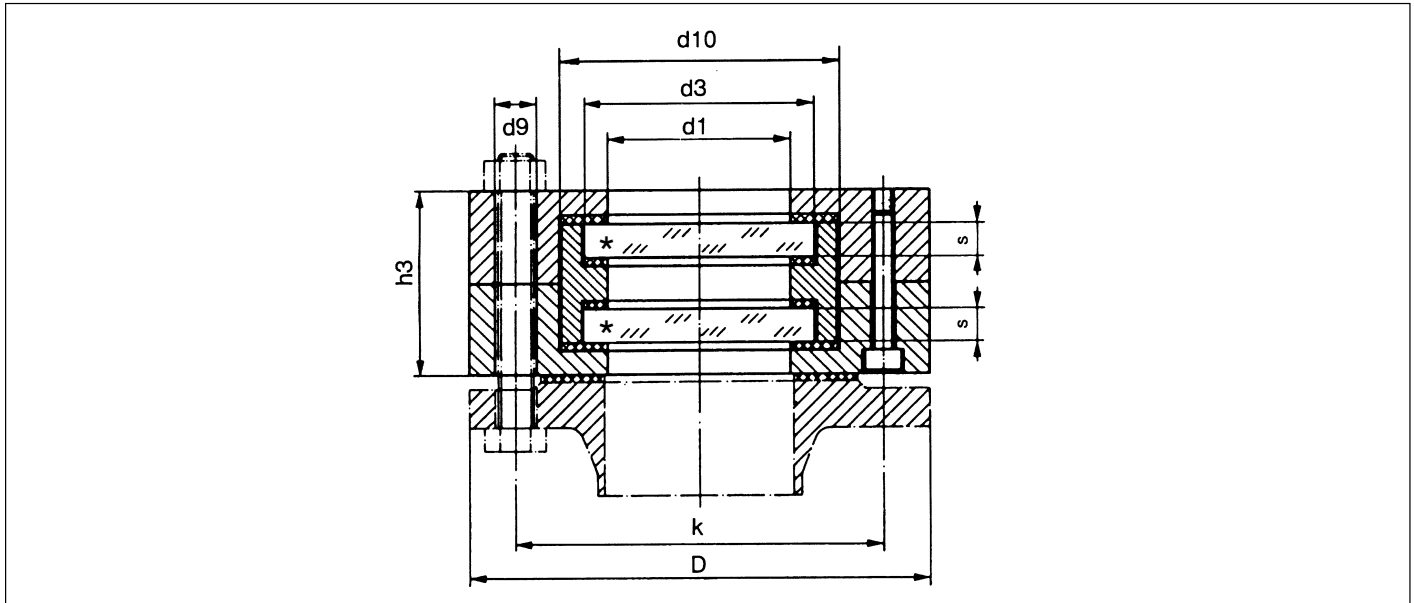

• **Mounting:**

The preassembled and compressed package is mounted onto nozzle weld flange, pad or similar, using the number and size of securing bolt shown on the following table.

Size		1	2	3	4	5	6
Nominal bore	DN	50	80	100	125	150	200
Viewing diameter	d1	65	80	100	125	150	175
Sight glass discs	d3	80	100	125	150	175	200
	s	10	15	15	20	20	25
Flanges	D	165	200	220	250	285	340
	k	125	160	180	210	240	295
	h3	77	81	85	102	102	102
Fastening bolts and nuts (are not part of delivery)	number of	4	8	8	8	8	8
	thread	M 16	M 16	M 16	M 16	M 20	M 20
	d9	18	18	18	18	22	22
Seals	d10	97	127	152	177	202	227
	d1	65	80	100	125	150	175
	d4 *	82	102	127	152	177	202

*size d4 (not shown) results from size d3 + 2 mm.
d4 = outer diameter of two inner seals.

• **Order data:**

Please specify the selected items as follows:

Fitting: nominal bore (DN), nominal pressure (PN)

Material:

- Base flange, e. g. stainless steel 1.4571 (if flat face is not required, please indicate form of sealing face)
- Mating flange, e. g. stainless steel 1.4571
- Glass disc, e. g. sodalime DIN 8902
- Seal, e. g. silicon

- **Test certificate type to DIN EN 10204 alternatively 3.1/3.2:**
customer request (extra cost)