

## GENERAL CHARACTERISTICS



### Design for side mounting

The principle of operation of these instruments is based on the drive of one or more magnetic reed contacts, placed inside of the measuring rod, by one or more floats. The only moving element is the float that moves, for buoyancy, along the measuring rod, this guarantees extreme robustness and a limited need for maintenance.

- **Brass – Spansil**
- Up to 4 switch points
- Maximum working pressure 20 bar
- Operating ambient temperature -30/+55°C UR 90%.
- Standard working temperature up to 105°C.
- Executions up to 120°C on request.
- Minimum degree of protection IP65.
- Built-in temperature sensors, on request.  
PT – PTC – NTC – Thermostat.
- ATEX Constructions (See Multipoint E – Multipoint I series)



## FLOATS

Tab.1



| Material           | Spansil – Butadiene - Acrylonitrile Copolymer |     |      |     |      |      |    |   |   |    |   |
|--------------------|---|-----|------|-----|------|------|----|---|---|----|---|
| Specific gravity   | 0,59  | 0,4 | 0,45 | 0,4 | 0,35 | 0,45 |    |   |   |    |   |
| Contact type       | 3   | 3   | 7D   | 3   | 3    | 7D   | 3  | 4 | 7 | 4  | 7 |
| Max N. of contacts | 1   | 1   | 3    | 4   | 4    | 4    | 4  |   |   | 4  |   |
| Max. bar           | 10  | 20  | 20   | 20  | 20   | 20   | 20 |   |   | 20 |   |
| Max. °C - Class    | L = 105°C                                     |     |      |     |      |      |    |   |   |    |   |
| On request         | M = 120°C                                     |     |      |     |      |      |    |   |   |    |   |

## ELECTRICAL CONTACTS

Tab.2

| TYPE    | POWER |    |  | VOLTAGE |     | CURRENT |     |
|---------|-------|----|--|---------|-----|---------|-----|
|         | VA    | W  |  | AC      | DC  | AC      | DC  |
| SPST 3  | 70    | 50 |  | 300     | 350 | 0,5     | 0,7 |
| SPST 4  | 80    | 80 |  | 250     | 250 | 1,3     | 1,3 |
| SPDT 7  | 60    | 60 |  | 230     | 230 | 1       | 1   |
| SPDT 7D | 20    | 20 |  | 150     | 150 | 0,5     | 0,5 |

## ELECTRICAL OUTPUT

Tab.3

| W1<br>IP65 Housing | W2<br>IP65 Housing | S1 – S2<br>DIN IP65 Plug               | C1 – C2 – T1<br>Cable – Leads                               | P1 – P2<br>Cable-gland             |
|--------------------|--------------------|--|---|------------------------------------|
| Max. 5 terminals   | Max. 18 terminals  | S1 DIN43650 29x29<br>S2 DIN43650 15x15 | C1 Cable L = 1,5m<br>C2 Cable L = 3,0m<br>T1 Leads L = 1,5m | P1 Brass IP68<br>P2 Polyamide IP67 |

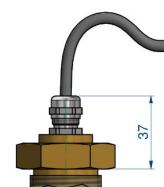
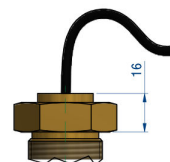
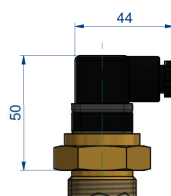
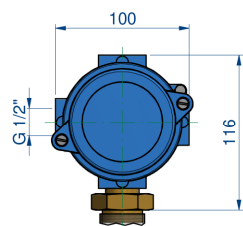
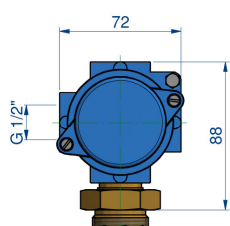

## PROCESS CONNECTIONS

Tab.4

| Installation from inside C- P-T output   |            |            |            | Float type | Installation from outside – available thread and flanges |            |          |              |              |          |                |                |              |   |   |   |
|--|------------|------------|------------|------------|--|------------|----------|--------------|--------------|----------|----------------|----------------|--------------|---|---|---|
| 06<br>1/8"                               | 08<br>1/4" | 10<br>3/8" | 15<br>1/2" |            | 15<br>1/2"   | 20<br>3/4" | 25<br>1" | 32<br>1 1/4" | 40<br>1 1/2" | 50<br>2" | FOHX<br>Flange | FOPX<br>Flange | DN<br>Flange |   |   |   |
| All type of floats<br>All type of thread |            |            |            | B13        | G-C-N  | -          | -        | -            | -            | -        | -              | -              | -            |   |   |   |
|  |            |            |            | B15        | -  | -          | G-C-N    | -            | -            | -        | -              | •              | •            | - |   |   |
|  |            |            |            | B20        | -  | -          | G        | G-C-N        | G-C-N        | -        | -              | -              | •            | • | • |   |
|  |            |            |            | B28        | -  | G-C-N      | G-C-N    | -            | -            | -        | -              | -              | -            | - | - |   |
|  |            |            |            | B44        | -  | -          | -        | -            | G            | G-C-N    | -              | -              | -            | - | - | • |
|  |            |            |            | B45        | -  | -          | G        | G-C-N        | G-C-N        | -        | -              | -              | •            | • | • |   |

### Male thread

|                       | C                  | N              |
|-----------------------|--------------------|----------------|
| Parallel<br>UNI 228/1 | Conical<br>UNI 7/1 | Conical<br>NPT |

### Available materials

| O     | D                     | S                      |
|-------|-----------------------|------------------------|
| Brass | Anodized<br>aluminium | AISI-316<br>On request |

### DN = Available materials

| C     | S                      |
|-------|------------------------|
| Steel | AISI-316<br>On request |

### FLANGES

Dimensions in mm.

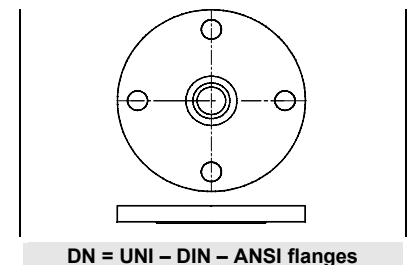
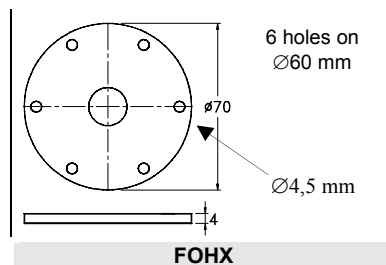
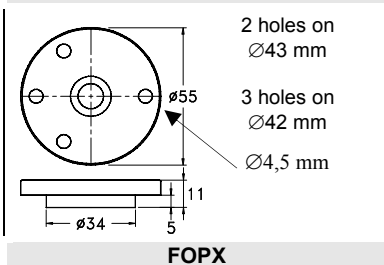

### WIRING

Tab.5

| I | Independent | Separately wired contacts          | 1 | NO   | Contacts status<br>in no level<br>conditions |
|---|-------------|------------------------------------|---|------|--|
| C | Common      | Common wired contacts              | 2 | NC   |  |
| S | Custom      | Contacts wired on customer request | 3 | SPDT |  |

### SWITCH POINTS

Tab.6

The switch points L1 ÷ L4 are measured from the axis of the fitting or flange connection.  
General tolerances on switch points ± 3 mm.

|                     | Minimum distance in mm. |     |      |      |     |     |     |
|---------------------|-------------------------|-----|------|------|-----|-----|-----|
|                     | B13                     | B15 | B20  | B28  | B44 | B45 |     |
| A min.              | 60                      | 55  | 60   | 60   | 80  | 60  | 60  |
| A1 min.             | 60                      | 55  | 60   | 60   | 80  | 70  | 75  |
| B                   | 25                      | 20  | 20   | 25   | 40  | 35  | 40  |
| C                   | -                       | 35  | 40   | -    | 75  | 65  | 75  |
| D max. ▶            | 18                      | 25  | 24   | 24   | 36  | 24  | 24  |
| Contact type        | 3                       | 3   | 3-7D | 3-7D | 4-7 | 3   | 4-7 |
| Max. N. of contacts | 1                       | 3   | 4    | 1    | 4   | 4   |     |

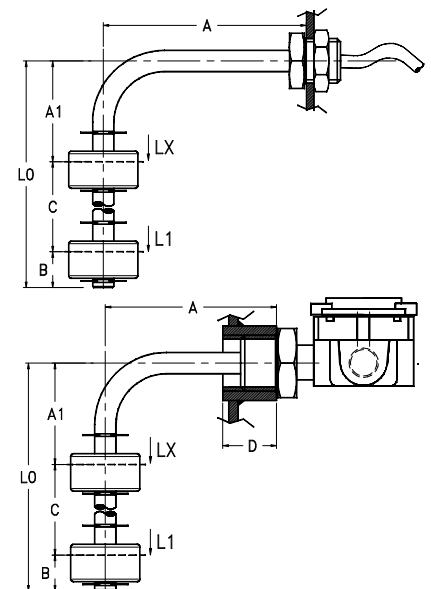

### OPTION – Built-in temperature sensor

On request, it is possible to install a temperature sensor located at the bottom of the rod inside the instrument.

| PT100 – PT1000                 | PTC                        | NTC                                 | TRM (Thermostat)                          |
|--------------------------------|----------------------------|-------------------------------------|---|
| EN 60751 – IEC 751             | Resistance at 25°C ≤ 500 Ω | Resistance at 25°C 2-5-10-50-100 KΩ | 40°C ÷ 120°C - 10°C step                  |
| Class B – (Class A on request) | Temperature 60°C ÷ 120°C   | Precision ± 5% / ± 3% (on request)  | Precision ± 5%<br>Differential 10°C ± 4°C |

### NOMENCLATURE

| L2 | B45 | 4 | 0350/0100 | O | 25 | G | O | W1 | L | I22 | L1÷L4 |  |
|----|-----|---|-----------|---|----|---|---|----|---|-----|-------|--|
| •  |     |   |           |   |    |   |   |    |   |     |       | Number of contacts L1÷L4                           |
|    | •   |   |           |   |    |   |   |    |   |     |       | Tab.1 Float  |
|    |     | • |           |   |    |   |   |    |   |     |       | Tab.2 Electrical contact                           |
|    |     |   | •         |   |    |   |   |    |   |     |       | - Length L0 in mm. / Length A in mm. (See drawing) |
|    |     |   |           | • |    |   |   |    |   |     |       | Tab.4 Rod material                                 |
|    |     |   |           |   | •  |   |   |    |   |     |       | Tab.4 Process connection dimension                 |
|    |     |   |           |   |    | • |   |    |   |     |       | Tab.4 Process connection thread                    |
|    |     |   |           |   |    |   | • |    |   |     |       | Tab.4 Process connection material                  |
|    |     |   |           |   |    |   |   | •  |   |     |       | Tab.3 Electrical output                            |
|    |     |   |           |   |    |   |   |    | • |     |       | Tab.1 Temperature class                            |
|    |     |   |           |   |    |   |   |    |   | •   |       | Tab.5 Wiring and contact status                    |
|    |     |   |           |   |    |   |   |    |   |     | •     | Tab.6 Switch points (mm)                           |