

Fittings and Accessories

For oil, fluid grease and grease lubrication systems and general use



Navigation

Introduction 2

Solderless pipe union with tapered sleeve 10

Solderless pipe union with cutting sleeve 38

Adapters 72

Quick Connectors 82

Manifolds 98

Tubes and Hoses 100

Fixing material 116

Couplings 122

Valves 126

Pressure gauges 134

Reservoirs and trays 138

Lubricating nipples 142

Filters 146

Brushes 150

Tools 152

Refill pumps 162

Table of contents

Two leading brands	8	High-pressure cutting sleeve unions acc. to ISO 8334-1	38
Lubricants suitable for lubrication systems	9	High-pressure cutting sleeve unions	39
Tapered sleeve fittings acc. to DIN 3854/DIN 3862	10	Fitting types	39
Provision of counterbore	12	Double-edged cutting sleeve union (DECS)	40
Form counterbores	14	Double-edged cutting sleeves D acc. to DIN 3861/ISO 8434-1	41
Double-tapered sleeves for metal pipes	14	Union nuts M acc. to DIN 3861/ISO 8434-1	42
Socket unions for metal pipes acc. to DIN 3871	15	Straight screw-in connectors GE with metrical thread	43
Reinforcing sockets for plastic tubes	15	Straight screw-in connectors GE with Whitworth pipe thread	44
Tapered sleeves for plastic tubes acc. to DIN 3862	16	Straight screw-in connectors GE with Whitworth pipe thread, made from stainless steel or brass	45
Connectors with tapered thread	17	Straight screw-in glands XGE	46
Connectors with cylindrical thread acc. to DIN 71428	18	Straight tube-to-tube connectors G	46
Bracketed connectors	20	Straight tube-to-tube reducing connectors GR	47
Tube-to-tube connector with air vent acc. to DIN 3862	21	Union studs GZ	48
T connectors acc. to DIN 71433	22	Straight tube studs EGE	48
Bulkhead connectors with tapered thread	24	T-connectors T	49
Tube-to-tube connectors	24	Reducing T-connectors TR	49
Straight bulkhead fittings acc. to DIN 71429	25	Elbow connectors W	50
Reducing piece	25	Elbow screw-in connectors WE with metrical thread	50
Threaded sockets	26	Elbow screw-in connectors WE with Whitworth pipe thread	51
Elbow bulkhead fittings acc. to DIN 71429	28	K-connectors K	52
Elbows with cylindrical thread acc. to DIN 71433	28	Female connector straight GAI with metrical thread	53
Elbows with tapered thread acc. to DIN 71429	29	Female connector straight GAI with Whitworth pipe thread	53
Elbows with tube end for pipe union for installation in counterbores acc. to DIN 3854/DIN 3862	30	Check valves GERV	54
Banjo fittings acc. to DIN 71430 Form A	31	Straight bulkhead connectors SV	56
Banjo fittings acc. to DIN 71430 Form B	32	Elbow bulkhead connectors WSV	56
Banjo fittings acc. to DIN 71430 Form C	33	Banjo fittings SWVE with metrical thread	57
Banjo fittings acc. to DIN 71430 Form D	33	Banjo fittings SWVE with Whitworth pipe thread	58
Banjo fittings, rotatable	34	Banjo fittings WH (high-pressure)	58
Banjo fitting with indicator pin for lubricant distributor	34	Reducing connectors RED with cylindrical thread	59
Rotating joints	35	Connectors for pressure gauges MAV	60
Cross joints	36	Connectors for pressure gauges MAV	60
Screw plugs sealed by flat washer acc. to DIN 7603	37	L-connectors EL, EVL directionally adjustable	61
Flat washers	37	Tee screw-in connectors TE, TH with metrical thread	62
		Tee screw-in connectors TE, TH with Whitworth pipe thread	62
		Swivel nut branch tee ET	63
		Swivel nut elbow EW	63
		Swivels DVWE	64
		Swivels DG	64
		Blanking plug for cones BUZ	65

Soft-seal cutting sleeve union (SSCS)	66	Quick connectors	82
Straight screw-in connectors GEZ	67	Single-seal quick connectors	85
Straight screw-in connectors with shortened thread and function nut GEZ (short)	68	Straight screw-in connectors	85
Straight bulkhead connectors with function nut SVZ	68	Straight screw-in connectors with PTFE threaded seal	85
Straight connectors (tube to tube) with function nut GZ	69	Adapters with tapered thread	86
Tee connectors with function nut TZ	69	Banjo fittings with tapered thread	86
Reducing connectors with function nut REDZ	70	Elbows with tapered thread	87
Cone plugs VKA	71	Banjo fittings with O-ring threaded seal	87
Adapter fittings	72	Banjo fittings with PTFE threaded seal	88
Reducing connectors with cylindrical thread for operating pressures up to 45 bar (sealed by flat washer acc. to DIN 7603)	74	Banjo fittings with hexagon socket and O-ring threaded seal	88
Reducing connectors with tapered thread for operating pressures up to 45 bar	74	T-Screw-in connector	89
Reducing connectors with cylindrical thread for operating pressures up to 45 bar (sealed by flat washer acc. to DIN 7603)	75	T-Connector	90
Adapter for pressure gauges for operating pressures up to 45 bar (sealed by flat washer acc. to DIN 7603)	75	Straight bulkhead connectors	90
Adapter for pressure gauges with cylindrical thread for operating pressures up to 45 bar	76	Tube-to-tube connector	91
Reducing connectors with tapered thread for operating pressures up to 350 bar	76	Triple-seal quick connectors	92
Elbow reducing connectors 45° with tapered thread for operating pressures up to 350 bar	77	Straight screw-in connectors with cylindrical thread	93
Elbow reducing connectors 90° with tapered thread for operating pressures up to 350 bar	77	Straight screw-in connectors with tapered thread	93
Reducing connectors RI with cylindrical thread for operating pressures up to 400 bar	78	Tube to tube connectors	94
Screw plugs VSTI	79	Banjo fittings with banjo bolt and cylindrical thread	94
Vent plugs with profile seal acc. to ISO 9974-2	79	Elbows with tapered thread	95
Banjo fittings, rotatable	80	Banjo fittings with cylindrical thread	96
		Banjo fittings with tapered thread	97
		Locking Pin	97
		Manifolds	98
		Metering device manifolds	99

Tubes and hoses	100	Valves	126
Plastic tubing	102	Relief valve	127
Tube protections	103	Relief valves with bleed valve and safety valve	127
Steel tubing	104	Pressure regulating valves, adjustable (poppet valve)	128
Stainless steel tubing	105	Adapters for valves	128
Low-pressure hoses for main lines max. 45 bar	106	Pressure regulating valves, fixed pressure	129
Low-pressure hoses for main lines max. 45 bar with tapered sleeve and socket union on both ends	107	Shut-off valves	131
Low-pressure hoses for main lines max. 45 bar with socket union on both ends and with claw groove for quick connector	108	Solenoid valves	133
Low-pressure hoses for secondary lines max. 15 bar	109	Pressure gauges	134
Low-pressure hoses for secondary lines max. 15 bar with tapered sleeve and socket union on both ends	109	Standard pressure gauges	135
Low-pressure hoses for secondary lines max. 15 bar with claw groove for quick connectors on both ends	110	Damped pressure gauges with restrictor	135
Low-pressure hoses suitable for self-installation max. 45 bar	111	Damped pressure gauges with glycerine filling	136
High-pressure hoses with pipe stud for high volume	112	Damped pressure gauges with glycerin filling and visualization in red/green	136
High-pressure hoses \varnothing 8.6 mm (ND4) pipe stud 6 mm	113	High-pressure gauges	137
High-pressure hoses for self-installation	114	Reservoirs	138
Threaded joints for high-pressure hoses	115	Plastic reservoirs	139
Fixing material	116	Oil trough with shut-off valve	140
Fixing clips	117	Metal reservoirs	141
Pipe brackets acc. to DIN 3015	120	Oil level gauges for metal reservoirs	141
Cable straps	120	Lubricating nipples	142
Mounting base	121	Hydraulic grease nipples according to DIN 71412	143
Fixing bolts	121	Button-head grease nipples according DIN 3404	143
Couplings	122	Lubrication fitting block	144
Low-pressure quick-disconnect couplings	123	Holder with lubricating nipple and fitting	144
Medium and high-pressure quick-disconnect couplings	123	Lubrication nipple manifolds	145
Coupling plugs	124	Lubricating nipple box	145
Coupling sockets with return flow port	125		

Filters	146
Screen filters for oil and fluid grease	147
Filter elements for oil and fluid grease filters.	147
Screen filters for grease	148
Filter elements for grease filter units.	149
 Brushes	 150
UC, 233, 068874	151
Suppot for brushes	151
 Tools	 152
Pipe cutter	153
Tube bender	155
Tube bending fix	156
Hose cutter	157
Grease pump set for pressure and function check	158
Drum plug wrench	159
Socket wrench insert for elbows	160
Mounting stud for hose couplings	161
 Refill pumps	 162
Powerluber	163
Manual grease filler guns	164
Filler cylinder	165
Manually and pneumatically operated filling pumps 169	166
Electrically operated filling pump EFPF	167
 Cross reference list	 168
 Index	 170
 Notes	 183

Two leading brands



One global leader

SKF and Lincoln have joined forces to provide you with the world's most complete portfolio of innovative lubrication solutions – from manual lubricators and tools, to the most advanced centralized and automatic lubrication systems available.

In addition to traditional lubrication products and systems, we offer customized solutions for many industries such as pulp and paper, steel, mining, agriculture, marine, rail, wind, construction, machine tool and automotive. SKF engineering and technical specialists partner with OEMs and end-users to develop system solutions based on customer requirements. We also offer a variety of control and monitoring equipment for ease of use and to help ensure proper lubrication.

Both SKF and Lincoln systems are available through our global network of lubrication experts, offering you world-class installation and ongoing support on a local level – today and into the future. With the power of this network, and more than 200 years of combined friction management experience, we can help you improve machine reliability, reduce maintenance, increase productivity, enhance safety and optimise manpower resources.

Lubricants suitable for lubrication systems

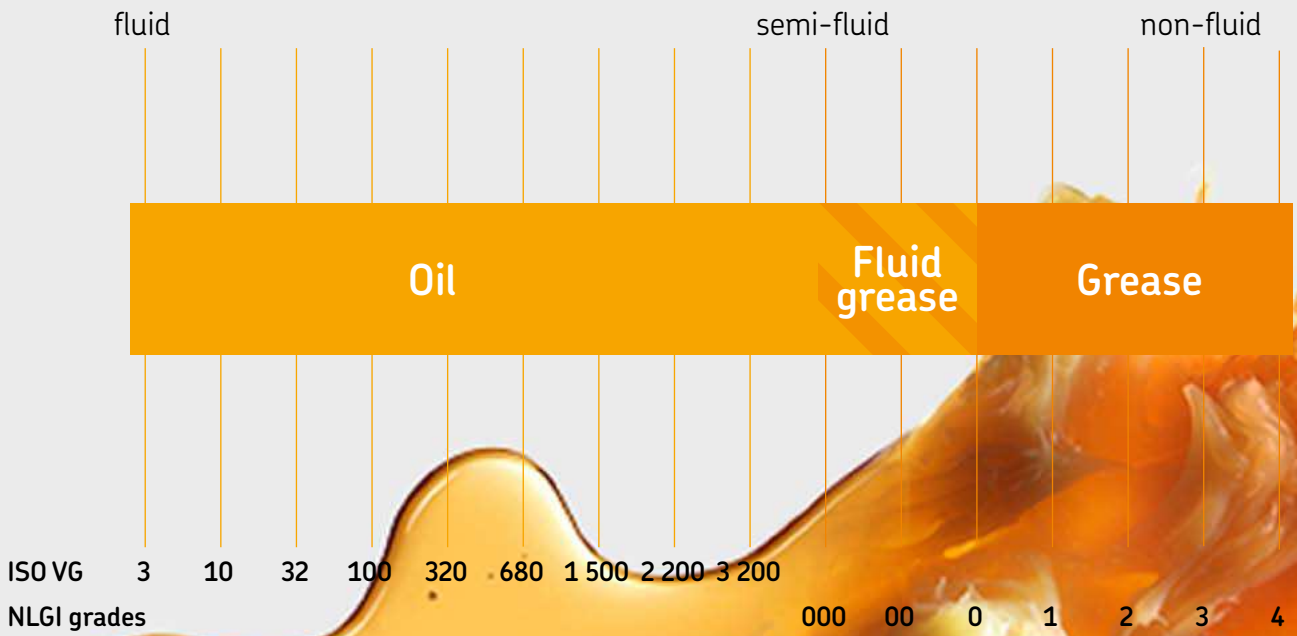

Oil and fluid grease

The viscosity is an expression of a fluid's internal friction. Oils are classified in ISO VG viscosity classes from 2 to 3 200. NLGI grade 000, 00 and 0 greases are called fluid greases. Different types of oils are available, including mineral oils, organic oils and synthetic oils. A compatibility check is recommended prior to using any oil with SKF lubrication systems.



Grease

Greases are consistent lubricants (NLGI grade 1–6). They are soft to hard, triple-component mixtures of a base oil as the lubricating fluid, a thickening agent and additives. In most instances, greases of NLGI grade 1 up to 3 are suitable for use in a lubrication system. A compatibility check should be made prior to using any grease with SKF lubrication systems.

Tapered sleeve fittings acc. to DIN 3854/DIN 3862

Low-pressure fittings for max. 45 bar

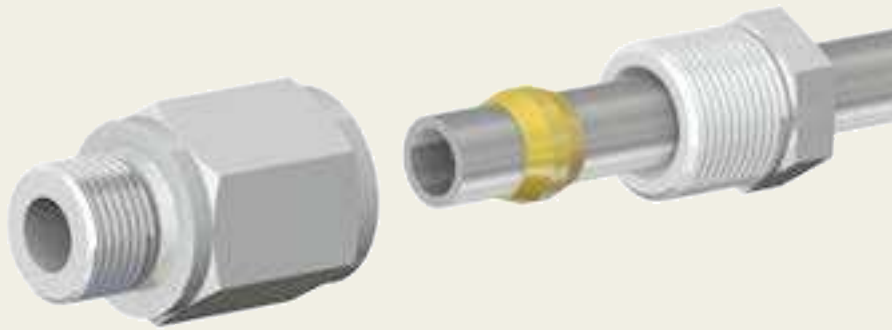

Description

Solderless pipe unions for metal and plastic pipes are designed for low pressure oil, fluid grease and grease lubrication systems with pressures up to 45 bar and an operating temperature range from -25 to 80 °C. Depending on the selection of metering pipe material, there are two different types of tapered sleeve fittings with different components available: Tapered sleeve fittings for plastic pipes and double-cone sleeve fittings for metal pipes. For both types of unions, a counterbore acc. to DIN 3862 is necessary.

Features and benefits

- Cost-efficient connection solution for low-pressure systems
- Suitable for oil, fluid grease and grease
- Simple and user-friendly assembly
- Virtually leakage-free union



Applications

- Paper and packaging industry
- Food and beverage industry
- Assembly and automation
- Part assembly lines
- Injection molding
- Mobile on-road
- Machine tools
- Etc.

Tapered sleeve fittings acc. to DIN 3854/DIN 3862

Provision of counterbore

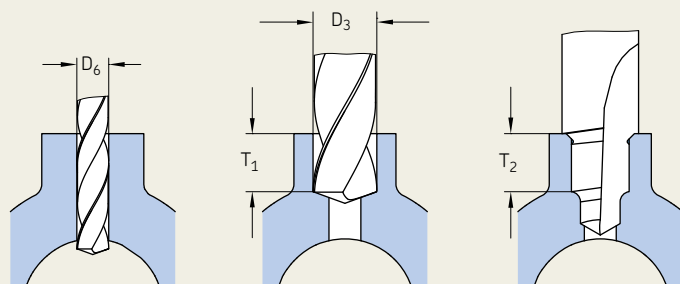

- 1 predrill holes
 - 2 predrill hole to be tapped
 - 3 counterbore with form counterbore up to the stop
- Form counterbore enlarges bore hole diam. D_4 to core hole for ISO thread.



Counterbores for solderless tube connection (DIN 3854/DIN 3862)

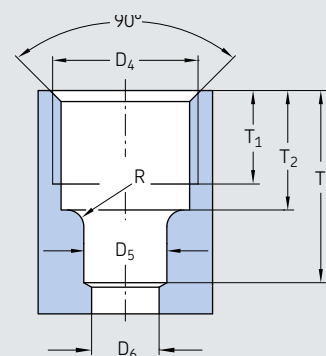

Description of counterbores

SKF offers a wide range of tapered sleeve fittings with counterbores according to DIN 3862. In addition, it is also possible to create counterbores by using offered tools as form counterbores.

Applications

- Small-to-medium machine tools
- Mobile on-road (fleet vehicles, on-road transport)
- Assembly and automation
- Food packaging
- Part assembly lines
- Injection molding

Description	Tube $\varnothing D$	$\varnothing D_5^{B11}$	$\varnothing D_6$	$\varnothing D_4$	T_1	T_2	T_3	R
	mm	mm	mm	mm	mm	mm	mm	mm
1102 ¹⁾	2,5	2,5	1,5	M6×0,75	4,5	5,5	8,5	1,3
1404	4	4	3	M8×1	6,5	8,5	12,5	1,6
1406	6	6	4,5	M10×1	7	9	14	1,6
1408	8	8	6,5	M14×1,5	9	11,5	18,5	1,6
1410	10	10	8,5	M16×1,5	9	11,5	19,5	1,6
1412	12	12	10,5	M18×1,5	9,5	12	22	1,6

1) not shown in DIN standard

! Important note for provision of counterbore:
When using a hand drill, take care not to tilt the counterbore out of the drill axis. To avoid damage, drill steadily without interruption. Increase pressure slightly at the stop.

Tapered sleeve fittings

Unions for metal pipes

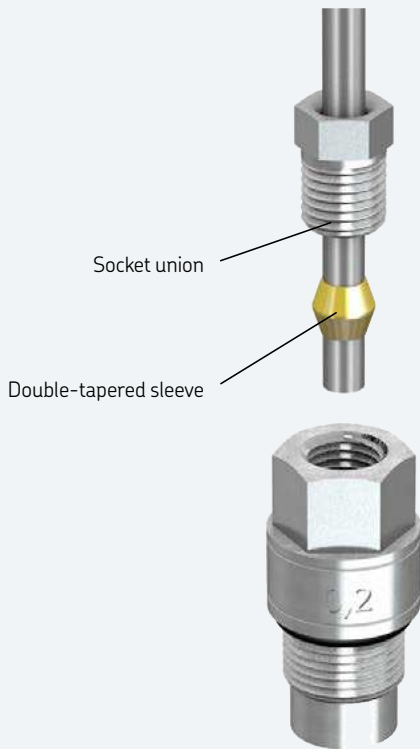

Unions for plastic pipes

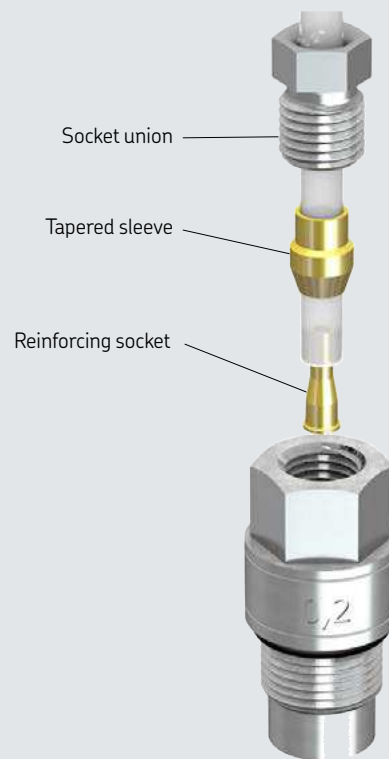

Solderless pipe unions for metal pipes

Description

Solderless pipe unions for metal pipes consist of a socket union, a double-cone sleeve and a fitting with counterbore according to DIN 2862.

Initial assembly

Cut the metal pipe straight to length using a suitable tool, e.g., a pipe cutter. Push the socket union and the double-cone sleeve onto the end of the metal pipe. Insert the end of the metal pipe into the depression until the stop and tighten the socket union finger-tight. Then tighten the socket union again by a maximum of $1\frac{1}{2}$ revolutions.

Repeat assembly

After each time the screw union is loosened, the socket union must be firmly retightened (with the same force) as in the initial assembly.

Solderless pipe unions for plastic pipes

Description

Solderless pipe unions for plastic pipes consist of a socket union, a tapered sleeve, a reinforcing socket and a fitting with counterbore according to DIN 2862.

Initial assembly

Cut the plastic pipe straight to length using a suitable tool, e.g., a hose cutter. Insert the reinforcing socket into the end of the plastic pipe to stabilize the end of the pipe being assembled. This prevents the plastic pipe from being constricted during assembly. Push the socket union and the tapered sleeve onto the end of the plastic pipe. Insert the end of the plastic pipe into the depression until the stop and tighten the socket union finger-tight. Then tighten the socket union again by a maximum of $1\frac{1}{2}$ revolutions.

Repeat assembly

Each time after the screw union is loosened, the socket union must be firmly retightened (with the same force) as in the initial assembly.

Solderless pipe union with tapered sleeve

Form counterbores

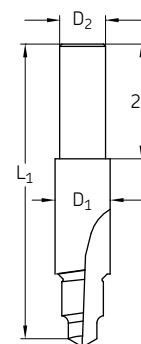

Form counterbores Order number	TubeØ	for counterbores	L ₁	D ₁	D ₂	twistdrill D ₆	D ₃	T ₁	T ₂
	mm		mm	mm	mm	mm	mm	mm	mm
902-111	2,5	1102	60,5	10	10	1,5	5	4,5	5,5
904-411	4	1404	65	10	10	3	6,5	7,5	8,5
906-411	6	1406	66	12	10	4,5	8,5	8	9
908-411	8	1408	70	16	10	6,5	12	10,5	11,5
910-411	10	1410	72	18	10	8,5	14	10,5	11,5
912-411	12	1412	75	20	10	10,5	16	11	12

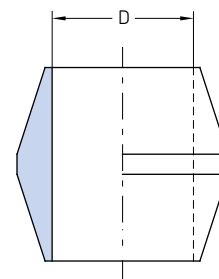
Double-tapered sleeves
for metal pipes

Order number	Designation	TubeØ D	Material	Weight	
				g	lb
Brass					
402-001 ¹⁾	DOUBLE CONE SLEEVE MS 2,5	2,5	Brass	21	0.05
404-001	DOUBLE CONE SLEEVE MS 4	4	Brass	34	0.07
406-001	DOUBLE CONE SLEEVE MS 6	6	Brass	66	0.15
408-001	DOUBLE CONE SLEEVE MS 8	8	Brass	80	0.18
410-001	DOUBLE CONE SLEEVE MS 10	10	Brass	100	0.22
412-001	DOUBLE CONE SLEEVE MS 12	12	Brass	120	0.26
Stainless steel					
404-001-S3	DOUBLE CONE SLEEVE VA 4	4	Stainless steel	34	0.07
406-001-S3	DOUBLE CONE SLEEVE VA 6	6	Stainless steel	66	0.15
408-001-S3	DOUBLE CONE SLEEVE VA 8	8	Stainless steel	80	0.18

¹⁾ not shown in DIN standard

Solderless pipe union with tapered sleeve

Socket unions for metal pipes acc. to DIN 3871

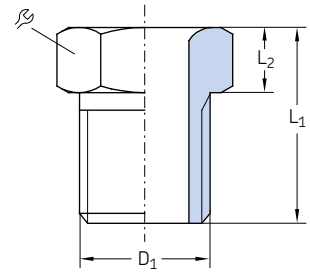

Order number	Designation	TubeØ	D ₁	L ₁	L ₂	☞	Material	Weight (100 pcs)	
								mm	mm
Steel, galvanized									
402-002	SOCKET UNION ST 2,5 - M6×0,75 ZN-LL	2,5	M6×0,75	9	3	7	Steel, galvanized	166	0.37
404-002	SOCKET UNION ST 4 - M8×1 ZN-LL	4	M8×1	12	4	8	Steel, galvanized	300	0.66
406-002	SOCKET UNION ST 6 - M10×1 ZN-LL	6	M10×1	13	4	10	Steel, galvanized	400	0.88
408-202	SOCKET UNION ST 8 - M14×1,5 ZN-L	8	M14×1,5	16	4,5	14	Steel, galvanized	1 000	2.21
410-002	SOCKET UNION ST 10 - M16×1,5 ZN-L	10	M16×1,5	17	5,5	17	Steel, galvanized	1 400	3.09
412-002	SOCKET UNION ST 12 - M18×1,5 ZN-L	12	M18×1,5	18	6	19	Steel, galvanized	1 800	3.97
Stainless steel									
404-002-S3	SOCKET UNION VA 4 - M8×1-L	4	M8×1	12	4	8	Stainless steel	300	0.66
406-002-S3	SOCKET UNION VA 6 - M10×1-L	6	M10×1	13	4	10	Stainless steel	400	0.88
408-202-S3	SOCKET UNION VA 8 - M14×1,5-L	8	M14×1,5	16	4,5	14	Stainless steel	1 000	2.21

Reinforcing sockets for plastic tubes

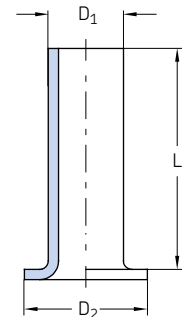

Order number	Designation	TubeØ	D ₁	D ₂	L	Material	Weight	
							mm	mm
402-603	REINFORCING SLEEVE MS F, TUBE 2,5×0,5	2,5×0,5	1,4	2,3	8	Brass	5	0.01
404-603	REINFORCING SLEEVE MS F, TUBE 4×0,85	4×0,85	2,2	3,8	10	Brass	8	0.02
406-603	REINFORCING SLEEVE MS F, TUBE 6×1	6×1	3,9	5,8	12	Brass	12	0.03
406-613	REINFORCING SLEEVE MS F, TUBE 6×1,25	6×1,25	3,4	5,8	12	Brass	15	0.03
408-603	REINFORCING SLEEVE MS F, TUBE 8×1,25	8×1,25	5,4	7,8	15	Brass	20	0.04
410-603	REINFORCING SLEEVE MS F, TUBE 10×1,5	10×1,5	6,9	9,8	18	Brass	24	0.05
412-603	REINFORCING SLEEVE MS F, TUBE 12×1,5	12×1,5	8,9	11,8	20	Brass	26	0.06

Solderless pipe union with tapered sleeve

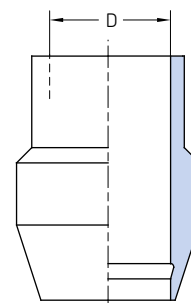
Tapered sleeves for plastic tubes
acc. to DIN 3862

Order number	Designation	TubeØ D mm	Material	Weight (100 pcs)	
				g	lb
402-611	CONE SLEEVE MS 2,5	2,5	Brass	100	0.22
404-611	CONE SLEEVE MS 4	4	Brass	120	0.26
406-611	CONE SLEEVE MS 6	6	Brass	160	0.35
408-611	CONE SLEEVE MS 8	8	Brass	200	0.44
410-611	CONE SLEEVE MS 10	10	Brass	250	0.55
412-611	CONE SLEEVE MS 12	12	Brass	300	0.66

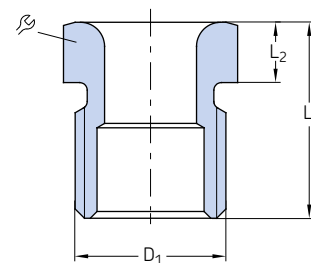
Socket unions for plastic tubes
acc. to DIN 3871

Order number	Designation	TubeØ D ₁ mm	L ₁ mm	L ₂ mm	ϕ	Material	Weight (100 pcs)		
							g	lb	
Steel, galvanized									
402-612	SOCKET UNION ST 2,5 - M6×0,75 ZN	2,5	M6×0,75	9	3	7	Steel, galvanized	100	0.22
404-612	SOCKET UNION ST 4 - M8×1 ZN	4	M8×1	12	4	8	Steel, galvanized	200	0.44
406-612	SOCKET UNION ST 6 - M10×1 ZN	6	M10×1	13	4	10	Steel, galvanized	300	0.66
408-612	SOCKET UNION ST 8 - M14×1,5 ZN	8	M14×1,5	16	4,5	14	Steel, galvanized	900	1.98
410-612	SOCKET UNION ST 10 - M16×1,5 ZN	10	M16×1,5	17	5,5	17	Steel, galvanized	1300	2.87
412-612	SOCKET UNION ST 12 - M18×1,5 ZN	12	M18×1,5	18	6	19	Steel, galvanized	1700	3.75
Brass									
404-612-MS	SOCKET UNION MS 4 - M8×1	4	M8×1	12	4	8	Brass	200	0.44
406-612-MS	SOCKET UNION MS 6 - M10×1	6	M10×1	13	4	10	Brass	300	0.66
408-612-MS	SOCKET UNION MS 8 - M14×1,5	8	M14×1,5	16	4,5	14	Brass	900	1.98
410-612-MS	SOCKET UNION MS 10 - M16×1,5	10	M16×1,5	17	5,5	17	Brass	1300	2.87

Solderless pipe union with tapered sleeve

Connectors with tapered thread

Tapered threads are used without washers; sealed by tapered outer thread and sealant according to DIN 3852-1.

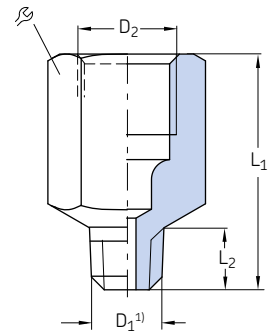

Order number	Designation	Tube		D ₂	L ₁	L ₂	R	Material	Weight	
		∅	D ₁ ¹⁾						g	lb
		mm	mm	mm	mm	mm	mm			
402-003K	CONNECTING PIECE ST 2,5 - M6×0,75K ZN	2,5	M6×0,75 tap.	M6×0,75	11,5	4,5	8	Steel, galvanized	2	0.004
402-006K	CONNECTING PIECE ST 2,5 - M8×1K ZN	2,5	M8×1 tap.	M6×0,75	15	8	9	Steel, galvanized	5	0.011
402-008K	CONNECTING PIECE ST 2,5 - M10×1K ZN	2,5	M10×1 tap.	M6×0,75	16	7,5	12	Steel, galvanized	11	0.024
404-662K	CONNECTING PIECE ST 4 - M6K ZN	4	M6 tap.	M8×1	19	5	11	Steel, galvanized	8	0.018
404-663K	CONNECTING PIECE ST 4 - M6K ZN	4	M6 tap.	M8×1	20	6	11	Steel, galvanized	8	0.018
404-673K	CONNECTING PIECE ST 4 - M6×0,75K ZN	4	M6×0,75 tap.	M8×1	20	6	11	Steel, galvanized	8	0.018
404-047K	CONNECTING PIECE ST 4 - M7K ZN	4	M7 tap.	M8×1	20	6	11	Steel, galvanized	9	0.02
404-003K	CONNECTING PIECE ST 4 - M8×1K ZN	4	M8×1 tap.	M8×1	17	7,4	11	Steel, galvanized	6	0.013
404-045	CONNECTING PIECE ST 4 - M8×1K ZN	4	M8×1 tap.	M8×1	62,5	7,4	11	Steel, galvanized	40	0.088
404-006K	CONNECTING PIECE ST 4 - M10×1K ZN	4	M10×1 tap.	M8×1	16	7,4	11	Steel, galvanized	7	0.015
401-004-512	CONNECTING PIECE ST 4 - M10×1K ZN	4	M10×1 tap.	M8×1	25	7,4	11	Steel, galvanized	14	0.031
404-040K	CONNECTING PIECE ST 4 - R1/8K ZN	4	R 1/8	M8×1	16	6	11	Steel, galvanized	7	0.015
404-040K-US	CONNECTING PIECE ST 4 - 1/8NPTF ZN	4	1/8 NPTF	M8×1	20	6,7	11	Steel, galvanized	10	0.022
404-054K	CONNECTING PIECE ST 4 - R1/4K ZN	4	R 1/4	M8×1	14	9	14	Steel, galvanized	11	0.024
404-072	CONNECTING PIECE ST 4 - 1/4-28UNF ZN	4	1/4-28 UNF	M8×1	20	5,6	11	Steel, galvanized	9	0.02
401-004-903	CONNECTING PIECE ST 4 - 1/4BSF ZN	4	1/4 BSF	M8×1	20	5	11	Steel, galvanized	9	0.02
401-004-904	CONNECTING PIECE ST 4 - 1.16 BSF ZN	4	1.16 BSF	M8×1	18	5	11	Steel, galvanized	7	0.015
406-004K	CONNECTING PIECE ST 6 - M10×1K ZN	6	M10×1 tap.	M10×1	23	7,4	14	Steel, galvanized	20	0.044
456-004K	CONNECTING PIECE ST 6 - R1/8K ZN	6	R 1/8	M10×1	21	6	14	Steel, galvanized	15	0.033
406-054K	CONNECTING PIECE ST 6 - R1/4K ZN	6	R 1/4	M10×1	20	9	17	Steel, galvanized	22	0.049

¹⁾Tapered thread according to DIN 158. short, resp. according to DIN 2999.

Solderless pipe union with tapered sleeve

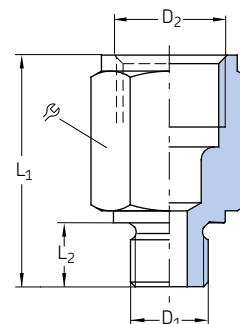
Connectors with cylindrical thread
acc. to DIN 71428

Order number	Designation	Tube		L ₁	L ₂	⌀	Material	Weight		
		∅	D ₁					D ₂	g	lb
		mm	mm	mm	mm	mm				
402-004	CONNECTING PIECE ST 2,5 - M6 ZN	2,5	M6	M6×0,75	13	5,5	9	Steel, galvanized	3	0.007
402-003	CONNECTING PIECE ST 2,5 - M6×0,75 ZN	2,5	M6×0,75	M6×0,75	13	5,5	9	Steel, galvanized	3	0.007
402-006	CONNECTING PIECE ST 2,5 - M8×1 ZN	2,5	M8×1	M6×0,75	15	7,5	11	Steel, galvanized	7	0.015
404-004	CONNECTING PIECE ST 4 - M8×1 ZN	4	M8×1	M8×1	24	14	11	Steel, galvanized	9	0.02
404-005	CONNECTING PIECE ST 4 - M8×1 ZN	4	M8×1	M8×1	32	22	11	Steel, galvanized	14	0.031
404-061	CONNECTING PIECE ST 4 - M5 ZN	4	M5	M8×1	20	5,5	11	Steel, galvanized	9	0.02
404-063	CONNECTING PIECE ST 4 - M8 ZN	4	M8	M8×1	22	8	11	Steel, galvanized	10	0.022
404-003	CONNECTING PIECE ST 4 - M8×1 ZN	4	M8×1	M8×1	18	7,5	11	Steel, galvanized	6	0.013
404-006	CONNECTING PIECE ST 4 - M10×1 ZN	4	M10×1	M8×1	18	7,5	14	Steel, galvanized	13	0.029
404-040	CONNECTING PIECE ST 4 - G1/8A ZN	4	G 1/8A	M8×1	18	8	14	Steel, galvanized	13	0.029
404-162	CONNECTING PIECE ST 4 - M12×1 ZN	4	M12×1	M8×1	18	9	17	Steel, galvanized	19	0.042
404-164	CONNECTING PIECE ST 4 - M14×1,5 ZN	4	M14×1,5	M8×1	18	9	17	Steel, galvanized	21	0.046
301-005-S3	CONNECTING PIECE VA 6 - M14×1,5	6	M14×1,5	M10×1	18	9	17	Stainless steel	19	0.042
406-004-S3	CONNECTING PIECE VA 6 - M10×1	6	M10×1	M10×1	18	7,5	14	Stainless steel	10	0.022
406-158-S3	CONNECTING PIECE VA 6 - M8×1	6	M8×1	M10×1	23	7,5	14	Stainless steel	15	0.033
267-001.17	CONNECTING PIECE MS 6 - G1/8A	6	G 1/8A	M10×1	24	8	14	Brass	18	0.04
406-163	CONNECTING PIECE MS 6 - M12×1	6	M12×1	M10×1	19	9	17	Brass	20	0.044
D301-005-MS	CONNECTING PIECE MS 6 - M14×1,5	6	M14×1,5	M10×1	20	9	17	Brass	24	0.053
406-167	CONNECTING PIECE MS 6 - M16×1,5	6	M16×1,5	M10×1	19	9	19	Brass	31	0.068
267-001.19	CONNECTING PIECE MS 6 - M18×1,5	6	M18×1,5	M10×1	21	10	22	Brass	71	0.157
406-158	CONNECTING PIECE ST 6 - M8×1 ZN	6	M8×1	M10×1	23	7,5	14	Steel, galvanized	38	0.084
406-004	CONNECTING PIECE 6 - M10×1 ZN	6	M10×1	M10×1	18	7,5	14	Steel, galvanized	10	0.022
406-162	CONNECTING PIECE ST 6 - M12×1 ZN	6	M12×1	M10×1	19	9	17	Steel, galvanized	18	0.04
406-054	CONNECTING PIECE ST 6 - G1/4A ZN	6	G 1/4A	M10×1	20	10	17	Steel, galvanized	20	0.044
301-005	CONNECTING PIECE ST 6 - M14×1,5 ZN	6	M14×1,5	M10×1	18	9	17	Steel, galvanized	18	0.04
406-166	CONNECTING PIECE ST 6 - M16×1,5 ZN	6	M16×1,5	M10×1	19	9	19	Steel, galvanized	28	0.062
406-055	CONNECTING PIECE ST 6 - G3/8A ZN	6	G 3/8A	M10×1	21	10	22	Steel, galvanized	41	0.09
D408-004-MS	CONNECTING PIECE MS 8 - M10×1	8	M10×1	M14×1,5	29	7,5	17	Brass	29	0.064
D301-001-MS	CONNECTING PIECE MS 8 - M14×1,5	8	M14×1,5	M14×1,5	28	9	17	Brass	29	0.064
D301-020-MS	CONNECTING PIECE MS 8 - G1/4A	8	G 1/4A	M14×1,5	30	10	17	Brass	30	0.066
267-001.13	CONNECTING PIECE MS 8 - G1/8A	8	G 1/8A	M14×1,5	24	12	27	Brass	71	0.157
301-020-S3	CONNECTING PIECE VA 8 - G1/4A	8	G 1/4A	M14×1,5	23	10	17	Stainless steel	17	0.037
408-004	CONNECTING PIECE ST 8 - M10×1 ZN	8	M10×1	M14×1,5	28	7,5	17	Steel, galvanized	25	0.055
408-154	CONNECTING PIECE ST 8 - G1/8A ZN	8	G 1/8A	M14×1,5	29	8	17	Steel, galvanized	26	0.057
408-160	CONNECTING PIECE ST 8 - G1/4A ZN	8	G 1/4A	M14×1,5	30	16	17	Steel, galvanized	22	0.049
408-162	CONNECTING PIECE ST 8 - M12×1 ZN	8	M12×1	M14×1,5	29	9	17	Steel, galvanized	26	0.057
301-020	CONNECTING PIECE ST 8 - G1/4A ZN	8	G 1/4A	M14×1,5	23	10	17	Steel, galvanized	16	0.035
301-001	CONNECTING PIECE ST 8 - M14×1,5 ZN	8	M14×1,5	M14×1,5	26	9	17	Steel, galvanized	23	0.051
408-005	CONNECTING PIECE ST 8 - M16×1,5 ZN	8	M16×1,5	M14×1,5	22	9	19	Steel, galvanized	30	0.066
408-006	CONNECTING PIECE ST 8 - M18×1,5 ZN	8	M18×1,5	M14×1,5	22	10	22	Steel, galvanized	40	0.088
408-022	CONNECTING PIECE ST 8 - M22×1,5 ZN	8	M22×1,5	M14×1,5	24	12	27	Steel, galvanized	71	0.157

Solderless pipe union with tapered sleeve

Connectors with cylindrical thread acc. to DIN 71428

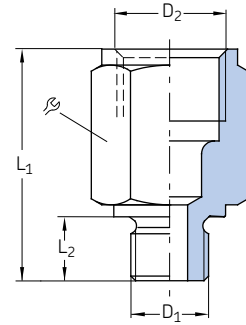

Tapered sleeve unions

Order number	Designation	Tube		D ₂	L ₁	L ₂	β	Material	Weight	
		∅	D ₁						g	lb
		mm	mm	mm	mm	mm	mm			
410-160	CONNECTING PIECE ST 10 - M10×1 ZN	10	M10×1	M16×1,5	30	7,5	19	Steel, galvanized	32	0.071
410-162	CONNECTING PIECE ST 10 - M12×1 ZN	10	M12×1	M16×1,5	31	9	19	Steel, galvanized	30	0.066
410-163	CONNECTING PIECE ST 10 - G1/4A ZN	10	G 1/4 A	M16×1,5	30	10	19	Steel, galvanized	30	0.066
410-164	CONNECTING PIECE ST 10 - M14×1,5 ZN	10	M14×1,5	M16×1,5	29	9	19	Steel, galvanized	30	0.066
410-169	CONNECTING PIECE ST 10 - G1/4A ZN	10	G 1/4 A	M16×1,5	52	16	19	Steel, galvanized	32	0.071
410-004	CONNECTING PIECE ST 10 - M16×1,5 ZN	10	M16×1,5	M16×1,5	23	9	19	Steel, galvanized	21	0.046
410-018	CONNECTING PIECE ST 10 - M18×1,5 ZN	10	M18×1,5	M16×1,5	24	10	22	Steel, galvanized	37	0.082
410-171	CONNECTING PIECE ST 10 - G1/2A ZN	10	G 1/2 A	M16×1,5	24	12	27	Steel, galvanized	58	0.128
410-022	CONNECTING PIECE ST 10 - M22×1,5 ZN	10	M22×1,5	M16×1,5	24	12	27	Steel, galvanized	64	0.141
412-162	CONNECTING PIECE ST 12 - M12×1 ZN	12	M12×1	M18×1,5	35	9	22	Steel, galvanized	52	0.115
412-163	CONNECTING PIECE ST 12 - G1/4A ZN	12	G 1/4 A	M18×1,5	35	10	22	Steel, galvanized	51	0.112
412-164	CONNECTING PIECE ST 12 - M14×1,5 ZN	12	M14×1,5	M18×1,5	33	9	22	Steel, galvanized	46	0.101
412-169	CONNECTING PIECE ST 12 - G1/4A ZN	12	G 1/4 A	M18×1,5	41	16	22	Steel, galvanized	49	0.108
412-004	CONNECTING PIECE ST 12 - M18×1,5 ZN	12	M18×1,5	M18×1,5	24	10	22	Steel, galvanized	28	0.062
412-014	CONNECTING PIECE ST 12 - M22×1,5 ZN	12	M22×1,5	M18×1,5	26	12	27	Steel, galvanized	63	0.139

Solderless pipe union with tapered sleeve

Bracketed connectors

504-004

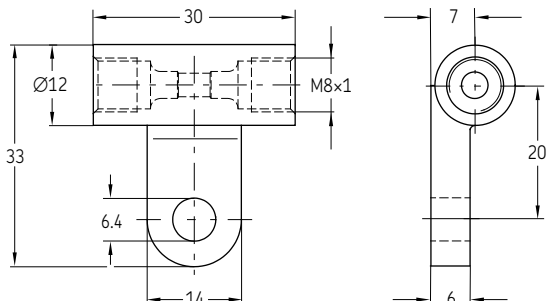

506-010

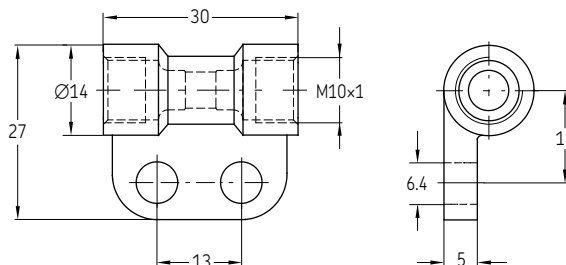

Order number	Designation	Tube Ø	Material	Weight	
				g	lb
Die-cast zinc 504-004	TUBE FITTING ZN G4 + BRACKET	4	Die-cast zinc	26	0.06
Brass 506-010	TUBE FITTING MS G6 + BRACKET	6	Brass	30	0.07

DAR506, DAR508

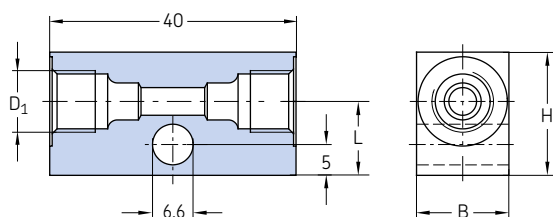

DAR510, DAR510-S1

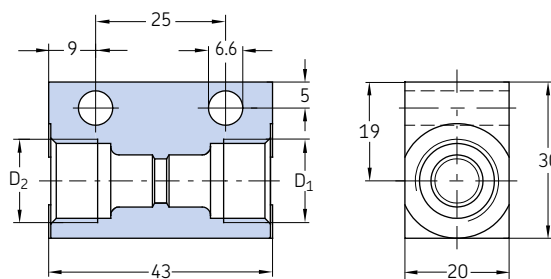

Order number	Designation	Tube Ø	D ₁	D ₂	B	H	L ₁	Material	Weight	
									mm	mm
Aluminum DAR506	TUBE FITTING AL G6 + BRACKET - M10x1	6	M10x1	-	15	20	12	Aluminum	26	0.06
DAR508	TUBE FITTING AL G8 + BRACKET - M14x1,5	8	M14x1,5	-	20	25	15	Aluminum	41	0.09
Steel, galvanized DAR510	TUBE FITTING ST G10 + BRACKET - M16x1,5 ZN	10	M16x1,5	M16x1,5	-	-	-	Steel, galvanized	140	0.31
DAR510-S1	TUBE FITTING ST G8/10 + BRACKET - M14x1,5 ZN	8/10	M14x1,5	M16x1,5	-	-	-	Steel, galvanized	150	0.33

Solderless pipe union with tapered sleeve

Bracketed connectors

DAR524

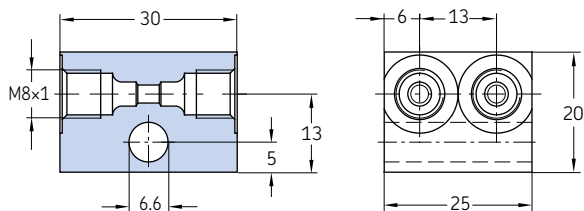

DAR534

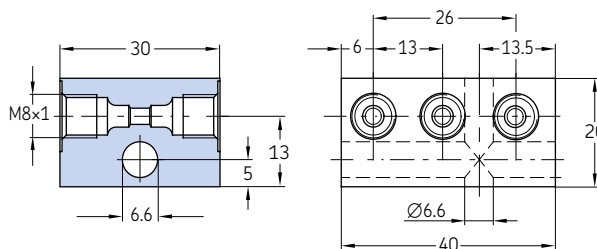

Order number	Designation	TubeØ	Material	Weight	
				g	lb
DAR524	TUBE FITTING ST 2XG4 + BRACKET ZN	4	Steel, galvanized	90	0.2
DAR534	TUBE FITTING ST 3XG4 + BRACKET ZN	4	Steel, galvanized	150	0.33

Tube-to-tube connector with air vent acc. to DIN 3862

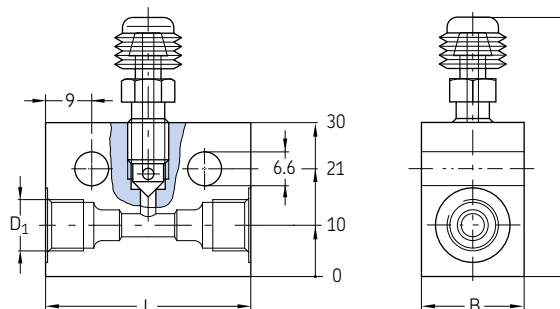

Order number	Designation	TubeØ	D ₁	B	H	L ₁	Material	Weight	
								g	lb
995-001-104	TUBE FITTING AL G 4 - M8x1 + VENTING	4	M8x1	20	50	40	Aluminum	68	0.15
995-001-106	TUBE FITTING AL G 6 - M10x1 + VENTING	6	M10x1	20	50	40	Aluminum	49	0.11

Solderless pipe union with tapered sleeve

T connectors acc. to DIN 71433

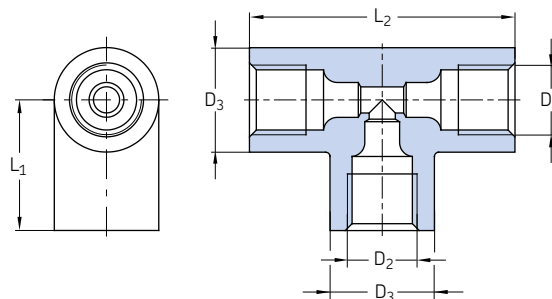

Order number	Designation	TubeØ	D ₁	D ₂	D ₃	L ₁	L ₂	Form	Material	Weight	
										g	lb
504-008	TUBE FITTING ZN T4 - M8×1	4	M8×1	M8×1	12	15	30,5	A	Die-cast zinc	20	0.04
506-008	TUBE FITTING ZN T6 - M10×1	6	M10×1	M10×1	14	18	36	A	Die-cast zinc	31	0.07
510-102	TUBE FITTING ZN T10 - M16×1,5	10	M16×1,5	M16×1,5	20	25	50	A	Die-cast zinc	62	0.14
506-408	TUBE FITTING ZN TR6/4 - M10×1	6/4	M10×1	M8×1	14	18	36	B	Die-cast zinc	33	0.07

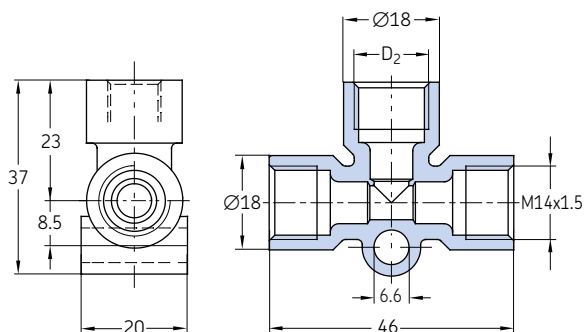

Order number	Designation	TubeØ	D ₂	Form	Material	Weight	
						g	lb
508-602-2	TUBE FITTING ZN TR8/6	8/6	M10×1	B	Die-cast zinc	58	0.13
508-002-2	TUBE FITTING ZN TR8	8	M14×1,5	A	Die-cast zinc	50	0.11

Solderless pipe union with tapered sleeve

T connectors acc. to DIN 71433

504-045

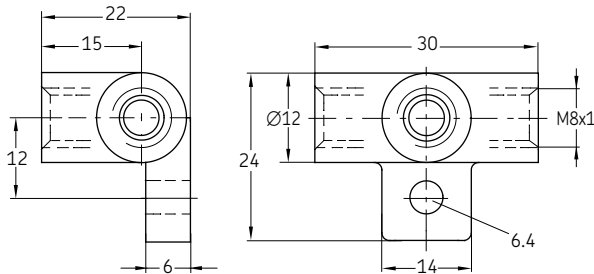

DY964

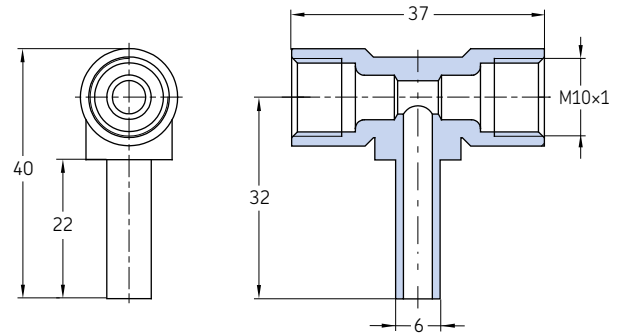

Order number	Designation	Tube Ø	Material	Weight	
				g	lb
504-045	TUBE FITTING ZN T4	4	Die-cast zinc	26	0.06
DY964	TUBE FITTING MST 6	6	Brass	38	0.08

DAT506 – DAT510

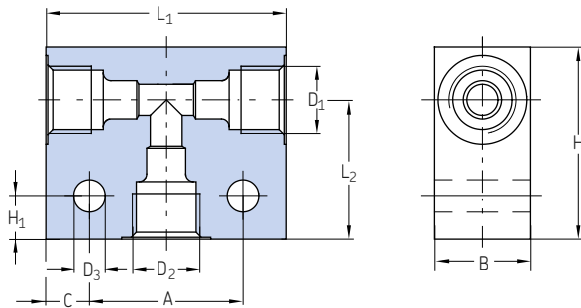

DAT510-S1

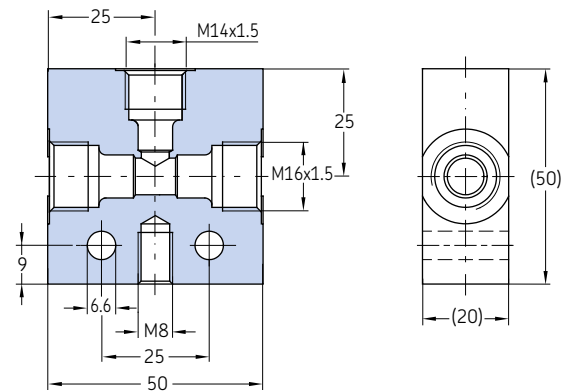

Order number	Designation	Tube Ø	D ₁	D ₂	D ₃	A	B	C	H	H ₁	L ₁	L ₂	Form	Material	Weight	
															g	lb
Aluminum																
DAT506	TUBE FITTING AL T6 - M10x1	6	M10x1	M10x1	6,6	22	20	9	30	9	40	20	A	Aluminum	55	0.12
DAT508	TUBE FITTING AL T8 - M14x1,5	8	M14x1,5	M14x1,5	6,6	32	20	9	40	9	50	29	A	Aluminum	90	0.2
DAT512	TUBE FITTING AL T12 - M18x1,5	12	M18x1,5	M18x1,5	6,6	42	25	9	40	9	60	29	A	Aluminum	123	0.27
DAT510-S5	TUBE FITTING AL T6 - M16x1,5	6	M16x1,5	M10x1	7	25	25	13,5	40	15	52	29	B	Aluminum	120	0.26
Steel, galvanized																
DAT510	TUBE FITTING ST T10 - M16x1,5	10	M16x1,5	M16x1,5	7	25	20	13,5	40	15	52	29	A	Steel, galvanized	230	0.51
DAT510-S1	TUBE FITTING ST TR10/8/10 ZN	8 (1x), 10 (2x)	M16x1,5	M14x1,5	6,6	25	20	12,5	50	9	50	25	B	Steel, galvanized	306	0.67

Solderless pipe union with tapered sleeve

Bulkhead connectors with tapered thread

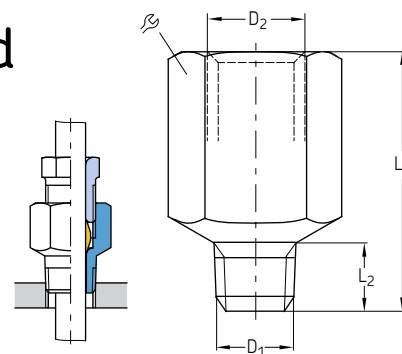

Order number	Designation	Tube Ø	D ₁ ¹⁾	D ₂	L ₁	L ₂	⌀	Material	Weight	
									mm	mm
404-003DK	BULKHEAD CONNECTORS ST 4 - M8×1 ZN	4	M8×1 tap.	M8×1	17	7,4	11	Steel, galvanized	6	0.013
404-006DK	BULKHEAD CONNECTORS ST 4 - M10×1 ZN	4	M10×1 tap.	M8×1	16	7,4	11	Steel, galvanized	7	0.015
406-004DK	BULKHEAD CONNECTORS ST 6 - M10×1 ZN	6	M10×1 tap.	M10×1	18	7,4	14	Steel, galvanized	10	0.022
301-001DK	BULKHEAD CONNECTORS ST 8 - M14×1,5 ZN	8	M14×1,5 tap.	M14×1,5	24	11	17	Steel, galvanized	19	0.042
410-004DK	BULKHEAD CONNECTORS ST 10 - M16×1,5 ZN	10	M16×1,5 tap.	M16×1,5	24	11	19	Steel, galvanized	22	0.049

¹⁾ Tapered thread according to DIN 158 tap, short.

Tube-to-tube connectors

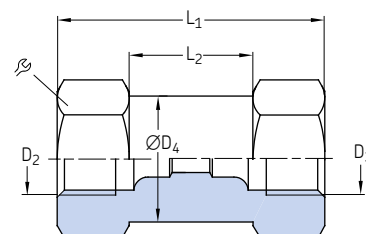

Order number	Designation	Tube Ø	D ₂	D ₃	ØD ₄	L ₁	L ₂	⌀	Material	Weight	
										mm	mm
404-010	TUBE FITTING ST G 4 ZN	4	M8×1	M8×1	10,8	27	13	11	Steel, galvanized	14	0.03
406-010	TUBE FITTING ST G 6 ZN	6	M10×1	M10×1	13,8	30	10	14	Steel, galvanized	25	0.06
406-805	TUBE FITTING ST GR 6/8 ZN	6/8	M14×1,5	M10×1	16,8	35	11	17	Steel, galvanized	43	0.09
408-010	TUBE FITTING ST G 8 ZN	8	M14×1,5	M14×1,5	16,8	40	14	17	Steel, galvanized	40	0.09
410-010	TUBE FITTING ST G 10 ZN	10	M16×1,5	M16×1,5	18,8	42	13	19	Steel, galvanized	54	0.12
412-010	TUBE FITTING ST G 12 ZN	12	M18×1,5	M18×1,5	21,8	48	18	22	Steel, galvanized	85	0.19

Solderless pipe union with tapered sleeve

Straight bulkhead fittings acc. to DIN 71429

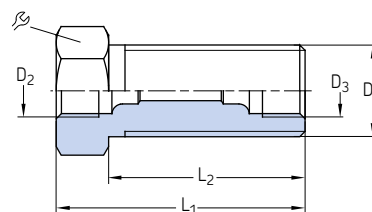

Order number	Designation	Tube Ø	D ₁ ¹⁾	D ₂	D ₃	L ₁	L ₂	Ø	Material	Weight	
										mm	mm
404-008	TUBE FITTING ST SV 4 - M14×1,5 ZN	4	M14×1,5	M8×1	M8×1	27	19	17	Steel, galvanized	30	0.07
404-009	TUBE FITTING ST SV 4 - M14×1,5 ZN	4	M14×1,5	M8×1	M8×1	38	30	17	Steel, galvanized	39	0.09
406-008	TUBE FITTING ST SV 6 - M14×1,5 ZN	6	M14×1,5	M10×1	M10×1	30	20	17	Steel, galvanized	30	0.07
406-005	TUBE FITTING ST SV 6/8 - M16×1,5 ZN	6/8	M16×1,5	M14×1,5	M10×1	35	23	19	Steel, galvanized	38	0.08
408-008	TUBE FITTING ST SV 8 - M20×1,5 ZN	8	M20×1,5	M14×1,5	M14×1,5	40	28	24	Steel, galvanized	75	0.17
410-008	TUBE FITTING ST SV 10 - M20×1,5 ZN	10	M20×1,5	M16×1,5	M16×1,5	42	27	24	Steel, galvanized	73	0.16
412-008	TUBE FITTING ST SV 12 - M24×1,5 ZN	12	M24×1,5	M18×1,5	M18×1,5	48	33	27	Steel, galvanized	114	0.25

Reducing piece

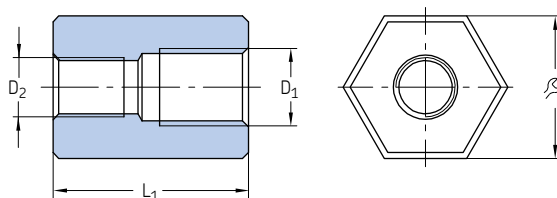

Order number	Designation	Tube Ø	D ₁	D ₂	L ₁	Ø	Material	Weight	
								mm	mm
44-1755-2019	REDUCING PIECE ST 4 - G1/4I X M10×1I SW24 ZN	4	G 1/4	M10×1	33	24	Steel, galvanized	100	0.22

Solderless pipe union with tapered sleeve

Threaded sockets

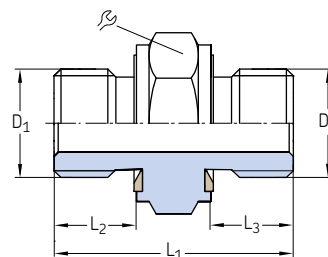

Order number	Designation	D ₁	D ₂	L ₁	L ₂	L ₃	ϕ	Seals	Material	Weight	
										mm	mm
402-116-161	THREADED SOCKET ST L29 - G1/4AZN	G 1/4 A	G 1/4 A	29	10	10	19	NBR	Steel, galvanized	30	0.07
402-116-165	THREADED SOCKET ST L37 - G1/2ZN	G 1/2	G 1/2	37	10	12	32	NBR	Steel, galvanized	100	0.22

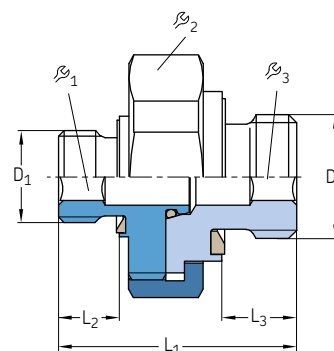

Order number	Designation	D ₁	D ₂	L ₁	L ₂	L ₃	ϕ ₁	ϕ ₂	ϕ ₃	Seals	Material	Weight	
												mm	mm
Steel, galvanized													
995-014-014	CONNECTOR ST G1/4A - G1/4AZN	G 1/4 A	G 1/4 A	26	8	8	4	24	5	NBR	Steel, galvanized	40	0.09
Brass													
995-340-000	CONNECTOR MS M10×1 - M10×1	M10×1	M10×1	19,5	6,5	6,5	4	16	4	FKM	Brass	13	0.03
995-340-350	CONNECTOR MS M10×1 - M12×1	M10×1	M12×1	21	6,5	7,2	4	19	5	FKM	Brass	20	0.04
995-350-000	CONNECTOR MS M12×1 - M12×1	M12×1	M12×1	21,5	7	7,2	5	19	5	FKM	Brass	20	0.04
995-340-000-S8	CONNECTOR MS M10×1 - M10×1	M10×1	M10×1	19,5	6,5	6,5	4	16	4	FKM	Brass	13	0.03
995-340-350-S8	CONNECTOR MS M10×1 - M12×1	M10×1	M12×1	21	6,5	7,2	4	19	5	FKM	Brass	18	0.04
995-350-000-S8	CONNECTOR MS M12×1 - M12×1	M12×1	M12×1	21,5	7	7,2	5	19	5	FKM	Brass	22	0.05

Solderless pipe union with tapered sleeve

Threaded sockets

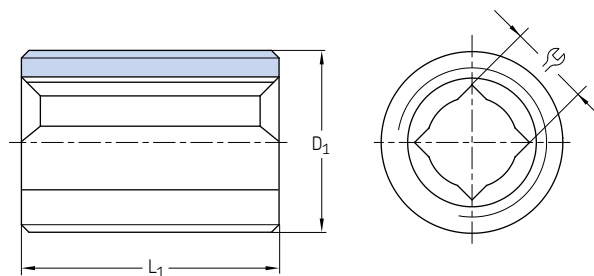

Order number	Designation	D ₁	L ₁	ϕ	Material	Weight	
						mm	mm
Steel							
404-203	THREADED SOCKET ST L13 - M8×1	M8×1	13	3,5	Steel	3	0.007
406-203	THREADED SOCKET ST L15 - M10×1	M10×1	15	3,5	Steel	6	0.013
406-243-B ¹⁾	THREADED SOCKET ST L18 - M10×1	M10×1	18	3,5	Steel	7	0.015
408-243-B ¹⁾	THREADED SOCKET ST L19 - M12×1	M12×1	19	5,5	Steel	9	0.02
458-012	THREADED SOCKET ST L17 - M12×1	M12×1	17	5,5	Steel	8	0.018
458-012-B ¹⁾	THREADED SOCKET ST L17 - M12×1	M12×1	17	5,5	Steel	8	0.018
408-023	THREADED SOCKET ST L18 - M14×1,5	M14×1,5	18	5,5	Steel	13	0.029
410-003	THREADED SOCKET ST L19 - M16×1,5	M16×1,5	19	7	Steel	16	0.035
410-003-B ¹⁾	THREADED SOCKET ST L19 - M16×1,5	M16×1,5	19	7	Steel	17	0.037
Stainless steel							
408-033-S3	THREADED SOCKET VA L15 - G1/4A	G 1/4 A	15	5,5	Stainless steel	9	0.02

¹⁾ Coated with microencapsulated adhesive

406-103, 408-103, 853-750-024

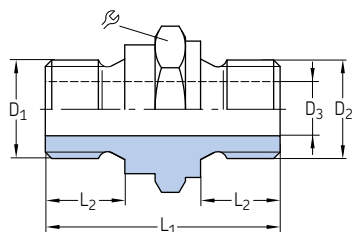

406-233

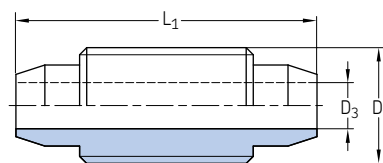

Order number	Designation	D ₁	D ₂	D ₃	L ₁	L ₂	ϕ	Material	Weight	
									mm	mm
Steel, galvanized										
406-103	THREADED SOCKET ST L20 - M10×1/M12×1 ZN	M10×1	M12×1	5	20	6	14	Steel, galvanized	14	0.03
408-103	THREADED SOCKET ST L21 - M12×1/M14×1,5 ZN	M12×1	M14×1,5	6	21	7	17	Steel, galvanized	21	0.05
853-750-024	THREADED SOCKET ST L31 - G1/4A/G1/4AZN	G 1/4 A	G 1/4 A	7	31	10,5	19	Steel, galvanized	29	0.06
Brass										
406-233	THREADED SOCKET MS L26 - M10×1	M10×1	-	4	26	-	-	Brass	8	0.02

Solderless pipe union with tapered sleeve

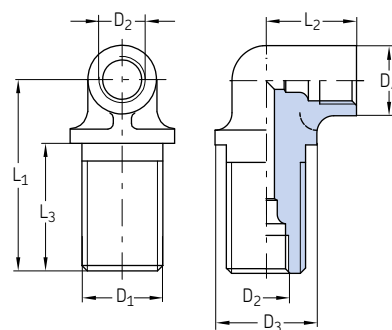
Elbow bulkhead fittings
acc. to DIN 71429

Order number	Designation	Tube Ø	D ₁	D ₂	D ₃	D ₄	L ₁	L ₂	L ₃	Material	Weight	
											mm	mm
Die-cast zinc 504-003	TUBE FITTING ZN WSV 4 - M14×1,5	4	M14×1,5	M8×1	18	12	33	16	22	Die-cast zinc	30	0.07
Brass 504-103	TUBE FITTING MS WSV 4 - M14×1,5	4	M14×1,5	M8×1	18	12	33	18	22	Brass	46	0.1
506-004	TUBE FITTING MS WSV 6 - M14×1,5	6	M14×1,5	M10×1	16,5	14	27	17,5	15	Brass	41	0.09

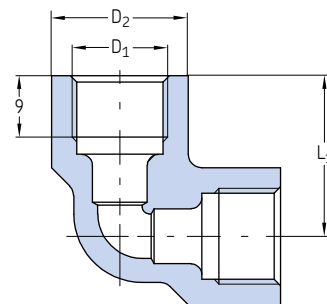
Elbows with cylindrical thread
acc. to DIN 71433

Order number	Designation	Tube Ø	D ₁	D ₂	L ₁	Material	Weight	
							mm	mm
408-013	TUBE FITTING ZN W8 - M14×1,5	8	M14×1,5	20	23,5	Die-cast zinc	40	0.09
410-013	TUBE FITTING ZN W10 - M16×1,5	10	M16×1,5	21	26	Die-cast zinc	58	0.13

Solderless pipe union with tapered sleeve

Elbows with tapered thread acc. to DIN 71429

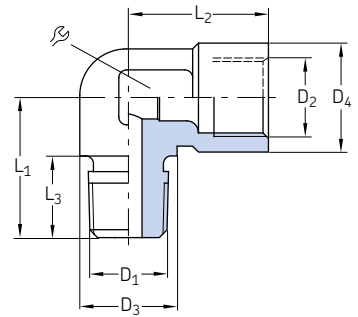

Order number	Designation	Tube		D ₂	D ₃	D ₄	L ₁	L ₂	L ₃	☉	Material	Weight	
		∅	D ₁ ¹⁾									g	lb
504-510K	ELBOWZN 4 - M10×1K	4	M10×1 tap.	M8×1	13	13	21	16	10	14	Die-cast zinc	24	0.05
514-018K	ELBOWZN 4 - R1/8	4	R 1/8	M8×1	13	13	21	16	10	14	Die-cast zinc	23	0.05
506-508K	ELBOWZN 6 - M8×1K	6	M8×1 tap.	M10×1	12,5	14	18	18	10,5	14	Die-cast zinc	18	0.04
506-510K	ELBOWZN 6 - M10×1K	6	M10×1 tap.	M10×1	12,5	14	18	18	10,5	14	Die-cast zinc	20	0.04
506-512K	ELBOWZN 6 - M12×1K	6	M12×1 tap.	M10×1	12,5	14	18	18	10,5	14	Die-cast zinc	21	0.05
508-512K	ELBOWZN 8 - M12×1K	8	M12×1 tap.	M14×1,5	14	19,5	19,5	24	10	14	Die-cast zinc	34	0.07

¹⁾ Tapered thread according to DIN 158 tap. short, resp. according to DIN 2999.

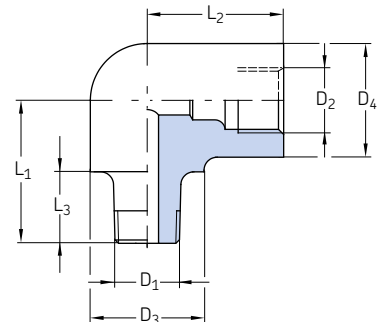

Order number	Designation	Tube		D ₂	D ₃	D ₄	L ₁	L ₂	L ₃	Material	Weight	
		∅	D ₁ ¹⁾								g	lb
Steel												
502-206K	ELBOW ST 2.5 - M6K	2,5	M6 tap.	M6×0,75	–	8	10	9,5	6	Steel	6	0.01
403-006-651	ELBOW ST 6 - R1/4K	6	R 1/4	M10×1	14	14	17	17,5	8,5	Steel	32	0.07
Brass												
506-202K	ELBOW MS 6 - M10X1K	6	M10×1 tap.	M10×1	17	17	22	21	11	Brass	60	0.13

¹⁾ Tapered thread according to DIN 158 tap. short, resp. according to DIN 2999.

Solderless pipe union with tapered sleeve

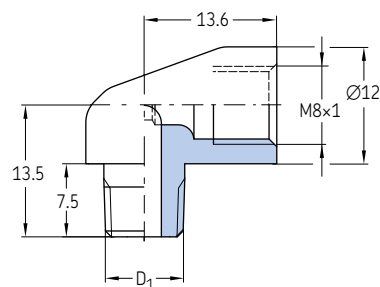
Elbows with tapered thread
acc. to DIN 71429

Order number	Designation	Tube Ø	D ₁ ¹⁾	Material	Weight	
					g	lb
504-200K	ELBOW MS 4 - M6K	4	M6 tap.	Brass	14	0.03
504-201K	ELBOW MS 4 - M8×1K	4	M8×1 tap.	Brass	20	0.04
504-202K	ELBOW MS 4 - M10×1K	4	M10×1 tap.	Brass	16	0.04
504-203K	ELBOW MS 4 - M6×0,75K	4	M6×0.75 tap.	Brass	14	0.03
514-018K-S1	ELBOW MS 4 - R1/8K	4	R 1/8	Brass	20	0.04

1) Tapered thread according to DIN 158. short, resp. according to DIN 2999.

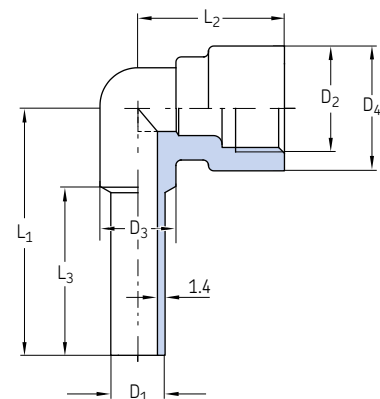
Elbows with tube end for pipe union
for installation in counterbores
acc. to DIN 3854/DIN 3862

Order number	Designation	Tube Ø	D ₁	D ₂	D ₃	D ₄	L ₁	L ₂	L ₃	Material	Weight	
											g	lb
DY958	ELBOW MS 6 - 6	6	6	M10×1	8	14	30,8	21	22	Brass	23	0.05
DY960	ELBOW MS 8 - 8	8	8	M14×1,5	11	18	37	24,5	27	Brass	37	0.08
DY961	ELBOW MS 10 - 10	10	10	M16×1,5	15	23	42,5	26,5	29	Brass	73	0.16
DY962	ELBOW MS 12 - 12	12	12	M18×1,5	15	23	46	26,5	32	Brass	62	0.14

Solderless pipe union with tapered sleeve

Banjo fittings acc. to DIN 71430 Form A

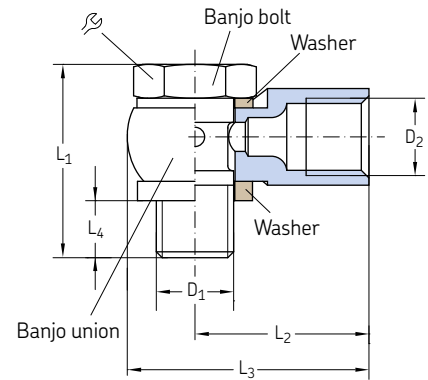

Order number	Designation	Tube		L ₁	L ₂	L ₃	L ₄	Banjo bolt	Banjo union	Banjo Material	Banjo Material	Weight (total)			
		∅	D ₁										D ₂	mm	mm
502-161 ¹⁾	BANJO FITTING SWVE 2,5 - M6	2,5	M6	M6×0,75	20	13	19	4,5	9	502-056	Steel, galv.	502-051	Steel, galv.	11	0.02
502-101 ¹⁾	BANJO FITTING SWVE 2,5 - M6×0,75	2,5	M6×0,75	M6×0,75	18	13	19	5	9	502-053	Steel, galv.	502-051	Steel, galv.	10	0.02
502-102 ¹⁾	BANJO FITTING SWVE 2,5 - M8×1	2,5	M8×1	M6×0,75	20	14	21	6,5	11	502-054	Steel, galv.	502-052	Steel, galv.	15	0.03
504-161 ¹⁾	BANJO FITTING SWVE 4 - M6	4	M6	M8×1	20	17	24	4,1	9	502-056	Steel, galv.	504-651	Steel, galv.	15	0.03
504-162 ¹⁾	BANJO FITTING SWVE 4 - M6×0,75	4	M6×0,75	M8×1	18	17	24	4,5	9	502-053	Steel, galv.	504-651	Steel, galv.	14	0.03
504-411 ¹⁾	BANJO FITTING SWVE 4 - M8	4	M8	M8×1	23	18	25	7,5	11	502-154	Steel, galv.	504-851	Steel, galv.	20	0.04
504-401 ¹⁾	BANJO FITTING SWVE 4 - M8×1	4	M8×1	M8×1	20	18	25	7	11	502-054	Steel, galv.	504-851	Steel, galv.	17	0.04
504-101	BANJO FITTING SWVE 4 - M8×1	4	M8×1	M8×1	26	18	25	6,5	11	504-073	Steel, galv.	504-072	Die-cast zinc	23	0.05
504-102	BANJO FITTING SWVE 4 - M10×1	4	M10×1	M8×1	26	19	27,5	6,5	14	504-054	Steel, galv.	504-052	Die-cast zinc	30	0.07
504-108	BANJO FITTING SWVE 4 - G1/8A	4	G 1/8 A	M8×1	27	19	27,5	6,8	14	504-027	Steel, galv.	504-052	Die-cast zinc	32	0.07
506-140	BANJO FITTING SWVE 6 - M10×1	6	M10×1	M10×1	26	21	28,5	6,5	14	504-054	Steel, galv.	506-033	Die-cast zinc	33	0.07
506-142	BANJO FITTING SWVE 6 - M12×1	6	M12×1	M10×1	34	25	35,2	7,5	17	558-012	Steel, galv.	506-030	Die-cast zinc	60	0.13
506-012	BANJO FITTING SWVE 6 - M14×1,5	6	M14×1,5	M10×1	34	25	35,2	7,5	17	508-006	Steel, galv.	506-005	Die-cast zinc	60	0.13
506-145	BANJO FITTING SWVE 6 - M16×1,5	6	M16×1,5	M10×1	35	30	41	8,7	19	510-017	Steel, galv.	506-034	Die-cast zinc	90	0.20
506-108	BANJO FITTING SWVE 6 - G1/8A	6	G 1/8 A	M10×1	27	21	28,5	7	14	504-027	Steel, galv.	506-033	Die-cast zinc	33	0.07
506-214	BANJO FITTING SWVE 6 - G1/4A	6	G 1/4 A	M10×1	35	25	35,2	8,5	17	508-023	Steel, galv.	506-005	Die-cast zinc	60	0.13
508-142	BANJO FITTING SWVE 8 - M12×1	8	M12×1	M14×1,5	34	27	37	7,5	17	558-012	Steel, galv.	508-030	Die-cast zinc	63	0.14
508-144	BANJO FITTING SWVE 8 - M14×1,5	8	M14×1,5	M14×1,5	34	27	37	7,5	17	508-006	Steel, galv.	508-007	Die-cast zinc	61	0.13
508-145	BANJO FITTING SWVE 8 - M16×1,5	8	M16×1,5	M14×1,5	35	30	41	8,7	19	510-017	Steel, galv.	508-054	Die-cast zinc	80	0.18
508-024	BANJO FITTING SWVE 8 - G1/4A	8	G 1/4 A	M14×1,5	35	27	37	8,5	17	508-023	Steel, galv.	508-007	Die-cast zinc	59	0.13
510-142	BANJO FITTING SWVE 10 - M12×1	10	M12×1	M16×1,5	34	30	40	7,5	17	558-012	Steel, galv.	510-041	Die-cast zinc	70	0.15
510-145	BANJO FITTING SWVE 10 - M16×1,5	10	M16×1,5	M16×1,5	35	30	41	10,7	19	510-017	Steel, galv.	510-044	Die-cast zinc	80	0.18
510-024	BANJO FITTING SWVE 10 - G1/4A	10	G 1/4 A	M16×1,5	35	30	40	7,5	17	508-023	Steel, galv.	510-023	Die-cast zinc	65	0.14

¹⁾ Miniature design, banjo union steel

Solderless pipe union with tapered sleeve

Banjo fittings acc. to DIN 71430 Form B

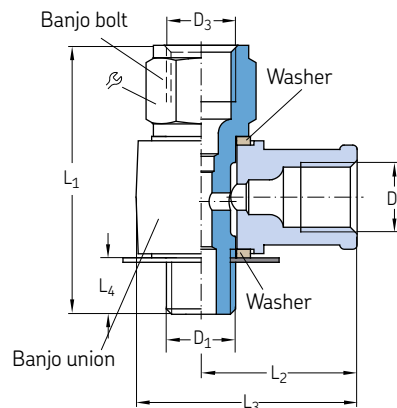

Order number	Designation	Tube				L ₁	L ₂	L ₃	L ₄	Banjo bolt	Ma- terial	Banjo union	Ma- terial	Weight (total)		
		∅	D ₁	D ₂	D ₃									g	lb	
504-114	TUBE FITTING LE 4 - M8X1	4	M8×1	M8×1	M8×1	31	18	25,5	6,5	11	504-075	1)	504-072	2)	24	0.05
504-115	TUBE FITTING LE 4 - M10X1	4	M10×1	M8×1	M8×1	31	19	27,5	6,5	14	504-056	1)	504-052	2)	34	0.07
504-105	TUBE FITTING LE 4/6 - M10X1	4/6	M10×1	M8×1	M10×1	33	19	27,5	6,5	14	506-056	1)	504-052	2)	34	0.07
405-619-061	TUBE FITTING LE 4/6 - G1/8A	4/6	G 1/8 A	M8×1	M10×1	33	19	27,5	6,3	14	402-606-191	1)	504-052	2)	33	0.07
506-114	TUBE FITTING LE 6 - M10X1	6	M10×1	M10×1	M10×1	33	21	28,5	6,3	14	506-006	1)	506-033	2)	35	0.08
506-342	TUBE FITTING LE 6 - M12X1	6	M12×1	M10×1	M10×1	38	25	35,2	7,5	17	558-612	1)	506-030	2)	62	0.14
506-101	TUBE FITTING LE 6 - M14X1,5	6	M14×1,5	M10×1	M10×1	40	25	35,2	7,5	17	508-303	1)	506-005	2)	70	0.15
586-342	TUBE FITTING LE 6/8 - M12X1	6/8	M12×1	M10×1	M14×1,5	44	25	35,2	7,5	17	558-812	1)	506-030	2)	64	0.14
506-013	TUBE FITTING LE 6/8 - M14X1,5	6/8	M14×1,5	M10×1	M14×1,5	43	25	35,2	7,5	17	508-008	1)	506-005	2)	61	0.13
506-345	TUBE FITTING LE 6/10 - M12X1	6/10	M12×1	M10×1	M16×1,5	48,5	25	35	7,7	19	558-912	1)	506-030	2)	77	0.17
506-346	TUBE FITTING LE 6/10 - M16X1,5	6/10	M16×1,5	M10×1	M16×1,5	50	30	41	8,7	19	510-010	1)	506-034	2)	100	0.22
508-342	TUBE FITTING LE 8 - M12X1	8	M12×1	M14×1,5	M14×1,5	44	27	37	7,5	17	558-812	1)	508-030	2)	67	0.15
508-012	TUBE FITTING LE 8 - M14X1,5	8	M14×1,5	M14×1,5	M14×1,5	43	27	37	7,5	17	508-008	1)	508-007	2)	63	0.14
508-034	TUBE FITTING LE 8 - G1/4A	8	G 1/4 A	M14×1,5	M14×1,5	44	27	37	7,5	17	508-033	1)	508-007	2)	65	0.14
568-342	TUBE FITTING LE 8/6 - M12X1	8/6	M12×1	M14×1,5	M10×1	38	27	37	7,5	17	558-612	1)	508-030	2)	65	0.14
508-304	TUBE FITTING LE 8/6 - M14X1,5	8/6	M14×1,5	M14×1,5	M10×1	40	27	37	7,5	17	508-303	1)	508-007	2)	66	0.15
508-345	TUBE FITTING LE 8/10 - M12X1	8/10	M12×1	M14×1,5	M16×1,5	48,5	27	37	7,7	19	558-912	1)	508-030	2)	80	0.18
508-346	TUBE FITTING LE 8/10 - M16X1,5	8/10	M16×1,5	M14×1,5	M16×1,5	50	30	41	8,7	19	510-010	1)	508-054	2)	93	0.21
510-342	TUBE FITTING LE 10 - M12X1	10	M12×1	M16×1,5	M16×1,5	48,5	30	40	7,5	19	558-912	1)	510-041	2)	81	0.18
510-344	TUBE FITTING LE 10 - M16X1,5	10	M16×1,5	M16×1,5	M16×1,5	50	30	41	8,7	19	510-010	1)	510-044	2)	89	0.20
510-343	TUBE FITTING LE 10 - G1/4A	10	G 1/4 A	M16×1,5	M16×1,5	48,5	30	40	7,5	19	558-913	1)	510-023	2)	78	0.17
510-346	TUBE FITTING LE 10/6 - M16X1,5	10/6	M16×1,5	M16×1,5	M10×1	50	30	41	8,7	19	506-018	1)	510-044	2)	96	0.21
510-341	TUBE FITTING LE 10/8 - M12X1	10/8	M12×1	M16×1,5	M14×1,5	44	30	40	7,5	17	558-812	1)	510-041	2)	69	0.15

1) Steel, galvanized
2) Die-cast zinc

Solderless pipe union with tapered sleeve

Banjo fittings acc. to DIN 71430 Form C

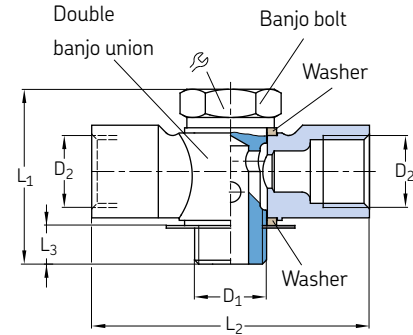

Order number	Designation	Tube Ø	D ₁	D ₂	L ₁	L ₂	L ₃	Banjo bolt	Material	Double banjo union	Material	Weight (total)		
												mm	mm	mm
504-109	TUBE FITTING TH4 - M8×1	4	M8×1	M8×1	26	38	6,5	11	504-073	Steel, galv.	504-071	Die-cast zinc	31	0.07
504-112	TUBE FITTING TH4 - M10×1	4	M10×1	M8×1	26	38	6,5	14	504-054	Steel, galv.	504-051	Die-cast zinc	35	0.08
506-242	TUBE FITTING TH6 - M12×1	6	M12×1	M10×1	34	48	7,5	17	558-012	Steel, galv.	506-032	Die-cast zinc	71	0.16
506-025	TUBE FITTING TH6 - M14×1,5	6	M14×1,5	M10×1	34	48	7,5	17	508-006	Steel, galv.	506-007	Die-cast zinc	70	0.15
508-242	TUBE FITTING TH8 - M12×1	8	M12×1	M14×1,5	34	54	7,5	17	558-012	Steel, galv.	508-032	Die-cast zinc	77	0.17
508-013	TUBE FITTING TH8 - M14×1,5	8	M14×1,5	M14×1,5	34	54	7,5	17	508-006	Steel, galv.	508-005	Die-cast zinc	77	0.17
508-025	TUBE FITTING TH8 - G1/4A	8	G1/4A	M14×1,5	35	54	7,5	17	508-023	Steel, galv.	508-005	Die-cast zinc	77	0.17
510-242	TUBE FITTING TH10 - M12×1	10	M12×1	M16×1,5	34	60	7,5	17	558-012	Steel, galv.	510-042	Die-cast zinc	83	0.18

Banjo fittings acc. to DIN 71430 Form D

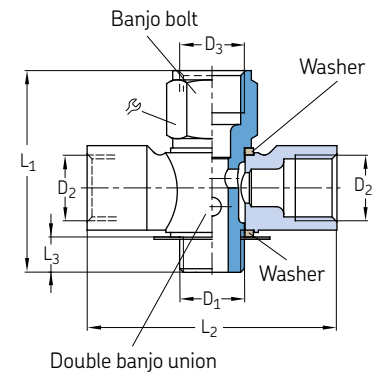

Order number	Designation	Tube Ø	D ₁	D ₂	D ₃	L ₁	L ₂	L ₃	Banjo bolt	Material	Double banjo union	Material	Weight (total)		
													mm	mm	mm
504-110	TUBE FITTING TH4 - M8×1	4	M8×1	M8×1	M8×1	31	38	6,5	11	504-071	1)	504-071	2)	32	0.07
504-111	TUBE FITTING TH4 - M10×1	4	M10×1	M8×1	M8×1	31	38	6,5	14	504-056	1)	504-051	2)	37	0.08
504-106	TUBE FITTING TH4/6 - M10×1	4/6	M10×1	M8×1	M10×1	33	38	6,5	14	506-006	1)	504-051	2)	37	0.08
506-442	TUBE FITTING TH6 - M12×1	6	M12×1	M10×1	M10×1	38	48	7,5	17	558-612	1)	506-032	2)	70	0.15
506-014	TUBE FITTING TH6 - M14×1,5	6	M14×1,5	M10×1	M10×1	40	48	7,5	17	508-303	1)	506-007	2)	73	0.16
586-442	TUBE FITTING TH6/8 - M12×1	6/8	M12×1	M10×1	M14×1,5	44	48	7,5	17	558-812	1)	506-032	2)	72	0.16
506-026	TUBE FITTING TH6/8 - M14×1,5	6/8	M14×1,5	M10×1	M14×1,5	43	48	7,5	17	508-008	1)	506-007	2)	70	0.15
508-442	TUBE FITTING TH8 - M12×1	8	M12×1	M14×1,5	M14×1,5	44	54	7,5	17	558-812	1)	508-032	2)	68	0.15
508-014	TUBE FITTING TH8 - M14×1,5	8	M14×1,5	M14×1,5	M14×1,5	43	54	7,5	17	508-008	1)	508-005	2)	79	0.17
568-442	TUBE FITTING TH8/6 - M12×1	8/6	M12×1	M14×1,5	M10×1	38	54	7,5	17	558-612	1)	508-032	2)	80	0.18
508-305	TUBE FITTING TH8/6 - M14×1,5	8/6	M14×1,5	M14×1,5	M10×1	40	54	7,5	17	508-303	1)	508-005	2)	90	0.20
510-442	TUBE FITTING TH10 - M12×1	10	M12×1	M16×1,5	M16×1,5	48,5	60	7,5	19	558-912	1)	210-042	2)	99	0.22

1) Steel, galvanized
2) Die-cast zinc

Solderless pipe union with tapered sleeve

Banjo fittings, rotatable

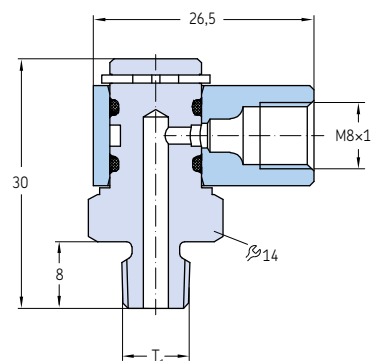

Order number	Designation	Tube ØD	Thread T ₁	Thread ₂	Speed max.	Oil pressure max.		Air pressure max.		Material	Weight	
						bar	psi	bar	psi		g	lb
405-549-049	BANJO FITTING MOVABLE M 8X1AX M8I 4	4	M8x1 tap.	M8x1	1	45	650	-	-	Brass	41	0.09
405-551-049	BANJO FITTING MOVABLE M10X1AX M8I 4	4	M10x1tap.	M8x1	1	45	650	-	-	brass	40	0.09

Banjo fitting with indicator pin for lubricant distributor

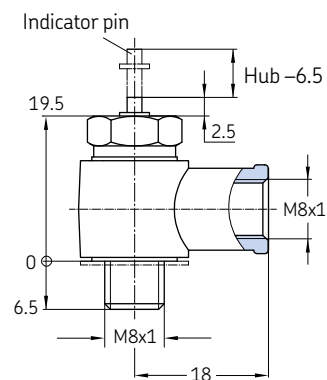

Order number	Designation	Tube Ø	Material	Weight	
				g	lb
169-200-008	BANJO FITTING SWVE 4- M8x1 +K	4	steel galv.	24	0.05

Solderless pipe union with tapered sleeve

Rotating joints

401-504-192

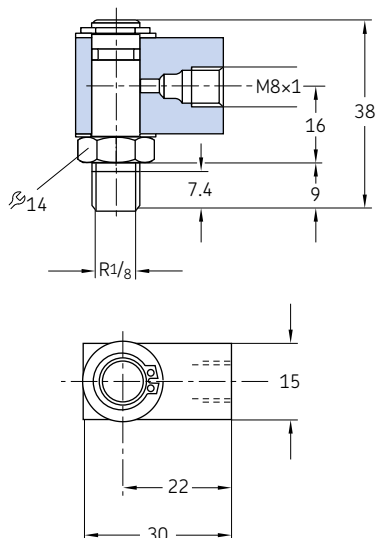

401-504-292

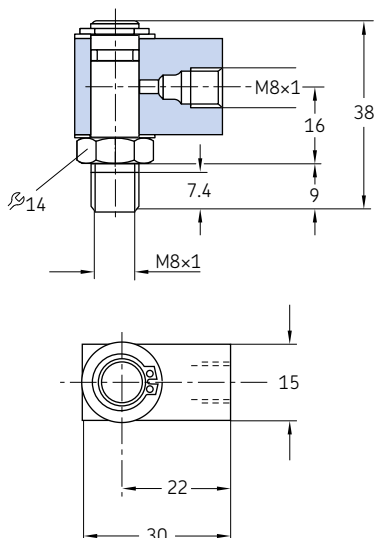

401-506-313

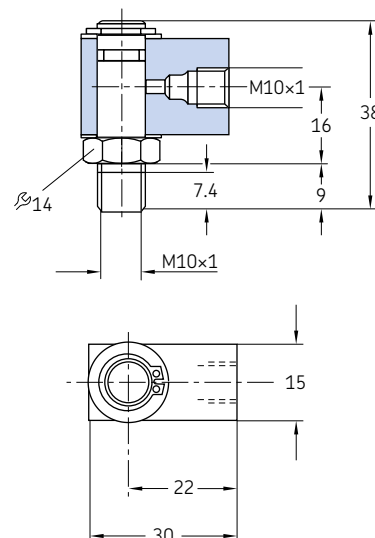

Order number	Designation	Tube ØD	Thread ₁	Thread ₂	Speed max.	Oil pressure max.		Air pressure max.		Material	Weight	
						bar	psi	bar	psi		g	lb
401-504-192	ROTATING JOINT	4	G 1/8	M8x1	100	30	435	8	116	Brass	81	0.18
401-504-292	ROTATING JOINT	4	M8x1	M8x1	100	30	435	8	116	Brass	80	0.18
401-506-313	ROTATING JOINT	6	M10x1	M10x1	100	30	435	8	116	Brass	77	0.17

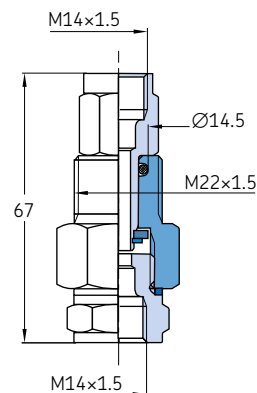

Order number	Designation	Tube ØD	Thread ₁	Thread ₂	Speed max.	Oil pressure max.		Air pressure max.		Material	Weight	
						bar	psi	bar	psi		g	lb
408-120	ROTATING JOINT	8	M14x1,5	M14x1,5	20	10	145	-	-	steel	200	0.44

Solderless pipe union with tapered sleeve

Cross joints

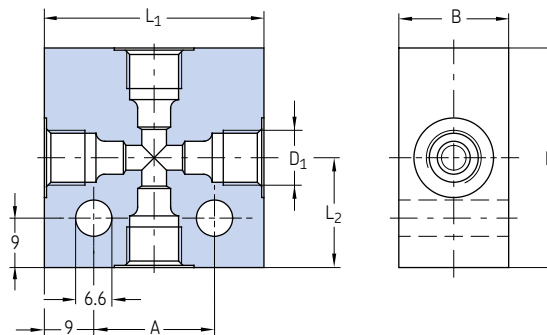

Order number	Designation	Tube Ø	D ₁	A	B	H	L ₁	L ₂	Material	Weight	
										mm	mm
DAK504-S1	TUBE FITTING AL K4/6 - M10×1/M8×1	4/6	M10×1/ M8×1	22	20	40	40	20	Aluminum	78	0.17
DAK506	TUBE FITTING AL K6 - M10×1	6	M10×1	22	20	40	40	20	Aluminum	75	0.17
DAK508	TUBE FITTING AL K8 - M14×1,5	8	M14×1,5	32	20	50	50	25	Aluminum	110	0.24
DAK510	TUBE FITTING AL K10 - M16×1,5	10	M16×1,5	25	20	56	50	28	Aluminum	115	0.25
DAK512	TUBE FITTING AL K12 - M18×1,5	12	M18×1,5	42	25	60	60	30	Aluminum	194	0.43

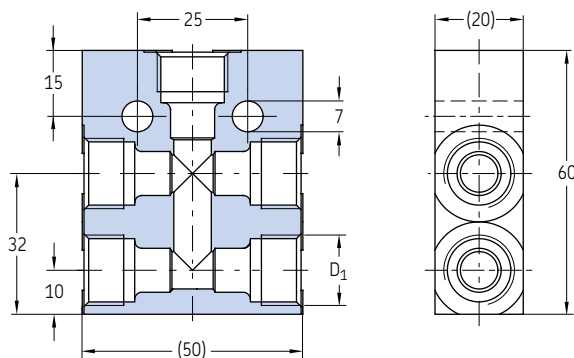

Order number	Designation	Tube Ø	D ₁	Material	Weight	
					mm	mm
DAK510-S1	TUBE FITTING ST K10×5 - M16×1,5 ZN	10	M16×1,5	Steel, galvanized	322	0.71

Solderless pipe union with tapered sleeve

Screw plugs sealed by flat washer acc. to DIN 7603

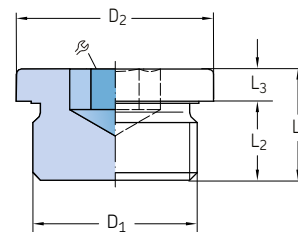

Order number	Designation	D ₁	D ₂	L ₁	L ₂	L ₃	⌀	Material	Weight	
		mm	mm	mm	mm	mm	mm		g	lb
DIN910-R1-8-5.8	PLUG,CLOSURE-HEX. ST 5.8 G 1/8AZN	G 1/8 A	14	17	8	3	11	Steel, galvanized	11	0.02
DIN910-R1-4x8-5.8	PLUG,CLOSURE-HEX. ST 5.8 G 1/4AZN	G 1/4 A	18	17	8	3	14	Steel, galvanized	19	0.04
DIN910-R3-8-5.8	PLUG,CLOSURE-HEX. ST 5.8 G 3/8AZN	G 3/8 A	22	21	12	3	17	Steel, galvanized	38	0.08
DIN910-R1-2-5.8	PLUG,CLOSURE-HEX. ST 5.8 G 1/2AZN	G 1/2 A	26	26	14	4	19	Steel, galvanized	68	0.15
DIN910-R3-4-5.8	PLUG,CLOSURE-HEX. ST 5.8 G 3/4AZN	G 3/4 A	32	30	16	4	24	Steel, galvanized	125	0.28
DIN910-R1-5-8	PLUG,CLOSURE-HEX. ST 5.8 G1 AZN	G 1 A	39	32	16	5	27	Steel, galvanized	199	0.44
402-011	PLUG,CLOSURE-HEX. ST M 6x0,75A SW10	M6x0.75	-	9	5	-	10	Steel, galvanized	4	0.01
404-011	PLUG,CLOSURE-HEX. ST M 8x1,0A SW11	M8x1	-	9,5	5,5	-	11	Steel, galvanized	5	0.01
406-011	PLUG,CLOSURE-HEX. ST M10x1,0A SW12	M10x1	-	12	7	-	12	Steel, galvanized	8	0.02
408-211	PLUG,CLOSURE-HEX. ST M12x1,0A SW17	M12x1	-	12	7	-	17	Steel, galvanized	14	0.03
408-011	PLUG,CLOSURE-HEX. ST M14x1,5A SW17	M14x1.5	-	12	7	-	17	Steel, galvanized	17	0.04
410-011	PLUG,CLOSURE-HEX. ST M16x1,5A SW19	M16x1.5	-	14	8	-	19	Steel, galvanized	25	0.06
412-011	PLUG,CLOSURE-HEX. ST M18x1,5A SW22	M18x1.5	-	15	10	-	22	Steel, galvanized	33	0.07
DIN 908-M10x1-5.8	PLUG,CLOS6-SOCK ST 5.8 M10X1,5ZN	M10x1	14	11	8	3	5 ¹⁾	Steel, galvanized	7	0.02
DIN 908-M12x1,5-5.8	PLUG,CLOS6-SOCK ST 5.8 M12X1,0ZN	M12x1.5	17	15	12	3	6 ¹⁾	Steel, galvanized	12	0.03
DIN 908-M14x1,5-5.8	PLUG,CLOS6-SOCK ST 5.8 M14X1,5ZN	M14x1.5	19	15	12	3	6 ¹⁾	Steel, galvanized	16	0.04
DIN 908-G1-8A-5.8	PLUG,CLOS6-SOCK ST 5.8 G 1/8AZN	G 1/8 A	14	11	8	3	5 ¹⁾	Steel, galvanized	5	0.01
DIN 908-G3-8A-5.8	PLUG,CLOS6-SOCK ST 5.8 G 3/8AZN	G 3/8 A	22	15	12	3	8 ¹⁾	Steel, galvanized	10	0.02

Flat washers

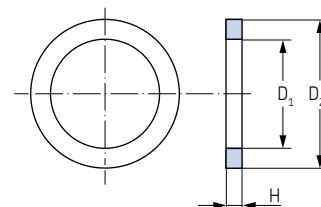

Order number	Designation	D ₁	D ₂	H	For thread	Material	Weight (100 pcs)	
		mm	mm	mm	mm		g	lb
504-019-AL	SEALING RING AL 10.2x13.9x1.1	10,2	13,9	1,1	M10	G 1/8 Aluminum	100	0.22
DIN7603-A6x10-CU	SEALING RING CU 6.2X9.9X1.0	6,2	9,9	1	M6	- Copper	100	0.22
DIN7603-A8x11.5-CU	SEALING RING CU 8.2X11.4X1.0	8,2	11,4	1	M8	- Copper	100	0.22
504-019	SEALING RING CU 10.2X13.9X1.1	10,2	13,9	1,1	M10	G 1/8 Copper	100	0.22
508-215-CU	SEALING RING CU 12.2X15.9X1.4	12,2	15,9	1,4	M12	- Copper	100	0.22
508-320-CU	SEALING RING CU 12.2X15.9X2.0	12,2	15,9	2	M12	- Copper	100	0.22
DIN7603-A12x18-CU	SEALING RING CU 12.2X14.9X1.0	12,2	14,9	1	M12	- Copper	100	0.22
508-108	SEALING RING CU 13.3X17.9X1.5	13,3	17,9	1,5	-	G 1/4 Copper	100	0.22
DIN7603-A14x18-CU	SEALING RING CU 14.2X17.9X1.5	14,2	17,9	1,5	M14	- Copper	200	0.44
DIN7603-A16x20-CU	SEALING RING CU 16.2X19.9X1.5	16,2	19,9	1,5	M16	- Copper	200	0.44
DIN7603-A17x21-CU	SEALING RING CU 17.2X20.9X1.5	17,2	20,9	1,5	-	G 3/8 Copper	200	0.44
DIN7603-A18x22-CU	SEALING RING CU 18.2X21.9X1.5	18,2	21,9	1,5	M18	- Copper	200	0.44
DIN7603-A20x24-CU	SEALING RING CU 20.2X23.9X1.5	20,2	23,9	1,5	M20	- Copper	200	0.44
DIN7603-A21x26-CU	SEALING RING CU 21.2X25.9X1.5	21,2	25,9	1,5	-	G 1/2 Copper	200	0.44
DIN7603-A22x27-CU	SEALING RING CU 22.2X26.9X1.5	22,2	26,9	1,5	M22	- Copper	300	0.66
DIN7603-A27x32-CU	SEALING RING CU 27.3X31.9X2.0	27,3	31,9	2	M27	- Copper	400	0.88
DIN7603-A30x36-CU	SEALING RING CU 30.3X35.9X2.0	30,3	35,9	2	M30	- Copper	500	1.10
DIN7603-A33x39-CU	SEALING RING CU 33.3X38.9X2.0	33,3	38,9	2	M33	- Copper	500	1.10

High-pressure cutting sleeve unions acc. to ISO 8334-1

DECS union



SSCS union



DECS union

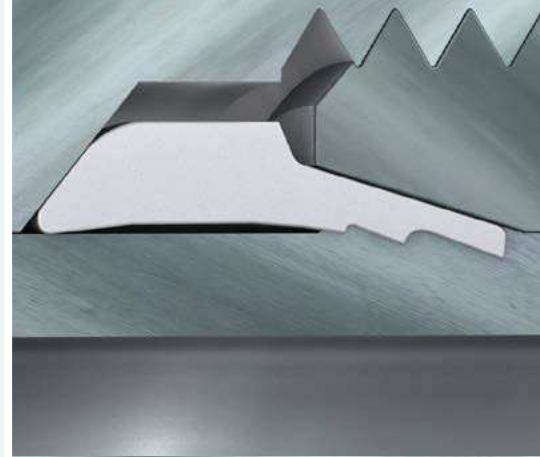

SSCS union

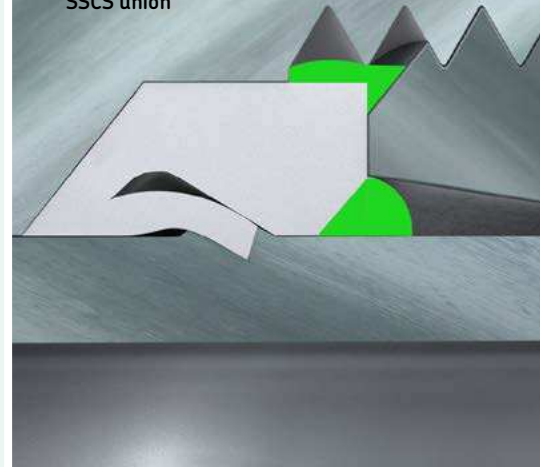

Description

Solderless pipe fittings with cutting sleeves are designed for high-pressure oil, fluid grease and grease lubrication systems with pressures up to 400 bar and more with an operating temperature range from -25 to 80 °C. Depending on the operating pressure, the fittings are available in 3 pressure series: LL (very light), L (light) and S (heavy). The pipe connections, threads and pressure series are defined in DIN EN ISO 8434-1 (formerly DIN 2353).

In consideration of the application, the fittings are available in various materials (galvanized steel, stainless steel and brass).

Cutting sleeve fittings, also called bite-type fittings, are very popular due to simple assembly that requires only two wrenches. It is recognised for its high-pressure performance from a compact body. During assembly, the cutting ring forms, cutting edges into the tube that will remain after reassembly. The cutting ring can also be preassembled by a manual device or with the help of a tool.

Series

	LL	L	S
Design	very light	light	rigid
Tube diameter (mm)	4, 6, 8, 10, 12	6, 8, 10, 12, 15	22, 26, 6, 8, 10, 12, 16, 20, 30
Nominal pressure	100 bar 1 450 psi	315 bar 4 568 psi	160 bar 2 320 psi 630 bar 9 137 psi 400 bar 5 800 psi
Operation pressure max.	200 bar 2 900 psi	500 bar 7 250 psi	250 bar 3 625 psi 900 bar 13 053 psi 420 bar 6 090 psi
Space requirement	very small	small	large
Lubrication systems	medium pressure lubrication systems		high pressure grease systems
Typical applications	vehicles, machine tools, wind mills		presses, injection molding machines, heavy industry

Types of cutting sleeve unions

- Double-edged cutting sleeve union (DECS)
- Soft-seal cutting sleeve union (SSCS)

High-pressure cutting sleeve unions

Fitting types

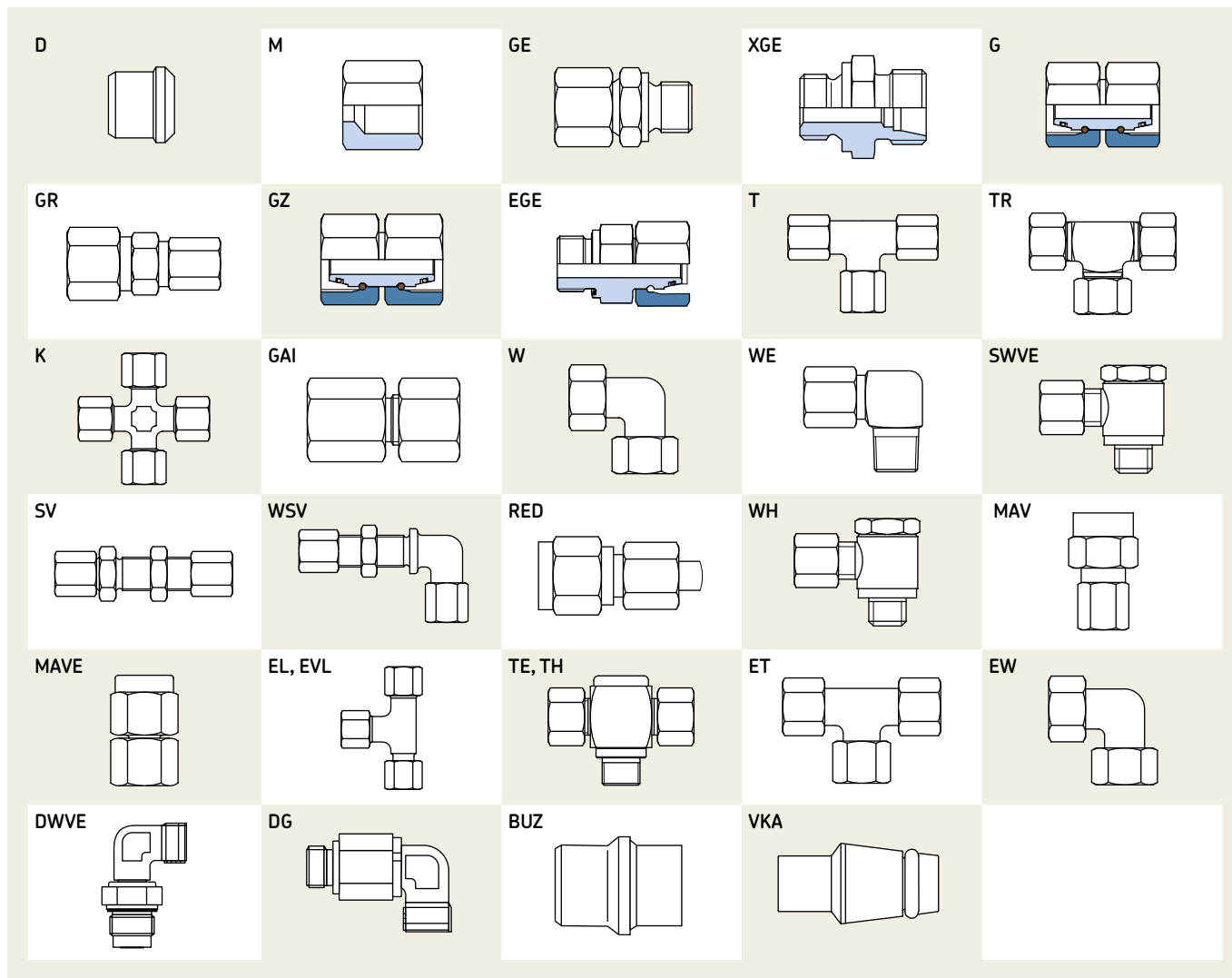

Nomenclature of fitting designations

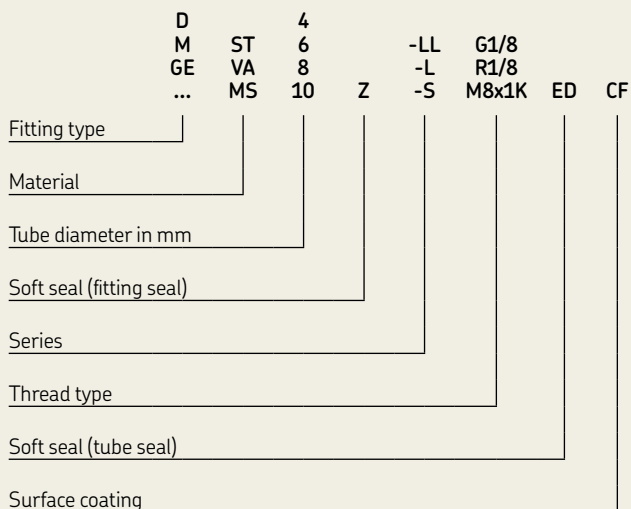

Legend of fitting type abbreviations

- D** Cutting sleeve
- M** Union nuts
- GE** Straight screw-in connector
- XGE** Straight screw-in gland
- G** Straight tube to tube connector
- GR** Straight tube to tube reducing connector
- GZ** Union stud
- EGE** Straight tube stud
- T** T-connector
- TR** T reducing connector
- K** K connector
- GAI** Female connector straight
- W** Elbow connector
- WE** Elbow screw-in connector
- SWVE** Banjo fitting
- SV** Straight bulkhead connector
- WSV** Elbow bulkhead connector
- RED** Reducing connectors
- WH** Banjo fitting (high-pressure)
- MAV** Connectors for pressure gauge
- MAVE** Connectors for pressure gauge (adjustable)
- EL** L-connectors adjustable
- EVL** Standpipe branch tee
- TE** T screw-in connector
- TH** T screw-in connector (high-pressure)
- ET** Swivel nut branch tee
- EW** Swivel nut elbow
- DWVE** Elbow male stud plain bearing rotary union
- DG** Elbow bulkhead ball bearing rotary union
- BUZ** Blanking plug for cones
- VKA** Blanking plug for cones

Double-edged cutting sleeve union (DECS)

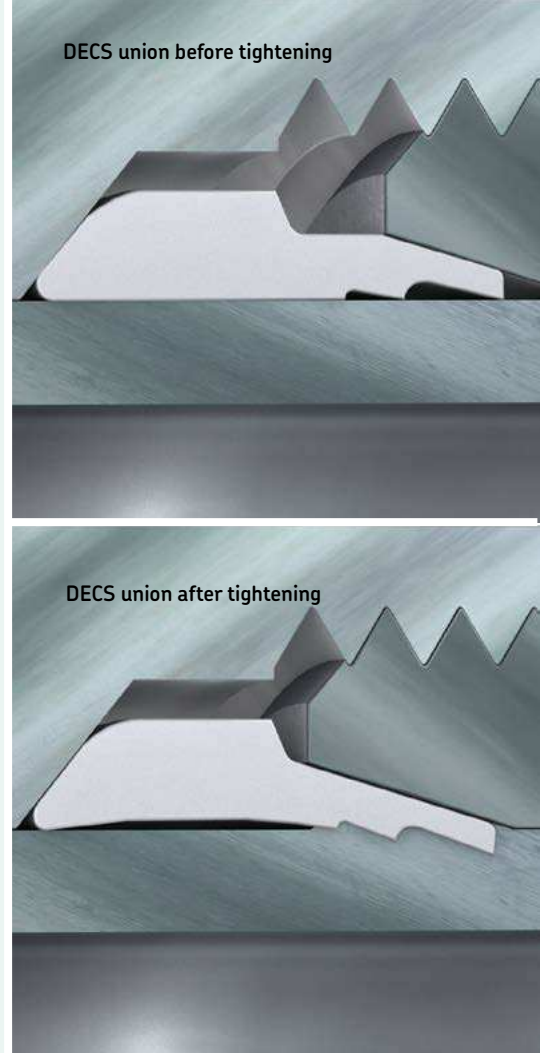
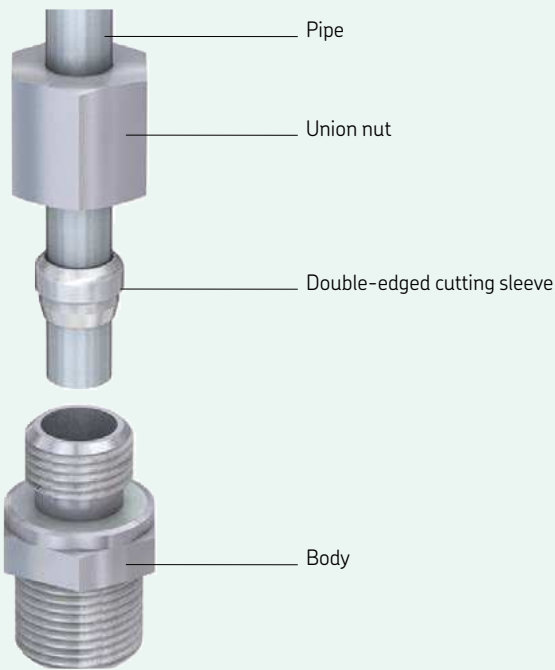

Description

Double-edged cutting sleeve unions (DECS) consist of a union nut, a double-edged cutting sleeve and a body. To mount the union, the union nut and double-edged cutting sleeve must be placed on the pipe end. Both parts must be aligned as shown on the illustration above. Then the pipe can be pushed into the body before tightening the union nut. During this process, the double-edged cutting sleeve cuts into the pipe to seal the connection as shown in the illustration above.

The following must be considered when tightening the union:

- Manual presetting – tighten the nut by 1 1/4 turns
- Final assembly – 1/4 turn after perceptible rise in force

Features and benefits

- Compact installation dimensions
- Virtually leakage-free, high-pressure union
- Recommended for high-pressure grease applications
- Suitable for thin and heavy pipes made from steel, stainless steel, copper and aluminum
- Common fitting system for high-pressure systems, especially for oil and grease lubrication
- Over-assembly protection through noticeable increase in force when tightening union nut
- Pipe vibration dampening resulting from pipe fixation during assembly (caused by DECS union)
- Wide operating temperature range from -25 to 80 °C

Double-edged cutting sleeve unions

Double-edged cutting sleeves D acc. to DIN 3861/ISO 8434-1

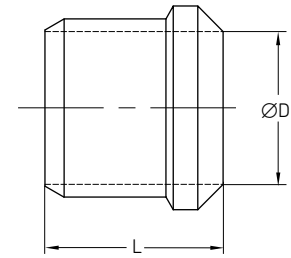

Order number	Designation	Series	Tube		Material	Operating pressure max.		Weight	
			ØD	L		bar	psi	g	lb
Steel, galvanized									
223-14083-3	CUTTING SLEEVE ST D 4-LL	LL	4	6	Steel, galvanized	100	1450	0,3	0.00
223-12295-2	CUTTING SLEEVE ST D 6-LL	LL	6	7	Steel, galvanized	100	1450	0,8	0.00
223-12295-5	CUTTING SLEEVE ST D 8-LL	LL	8	7	Steel, galvanized	100	1450	1	0.00
223-12295-9	CUTTING SLEEVE ST D 10-LL	LL	10	7	Steel, galvanized	100	1450	1,3	0.00
223-12295-3	CUTTING SLEEVE ST D 6-L/S	L/S	6	9,5	Steel, galvanized	250	3625	1	0.00
223-12295-6	CUTTING SLEEVE ST D 8-L/S	L/S	8	10	Steel, galvanized	250	3625	1,7	0.00
223-12295-8	CUTTING SLEEVE ST D 10-L/S	L/S	10	10	Steel, galvanized	250	3625	3,1	0.01
223-12296-1	CUTTING SLEEVE ST D 12-L/S	L/S	12	10,5	Steel, galvanized	250	3625	3,5	0.01
223-12296-9	CUTTING SLEEVE ST D 15-L	L	15	10	Steel, galvanized	160	2320	4,5	0.01
223-12583-1	CUTTING SLEEVE ST D 18-L	L	18	10,5	Steel, galvanized	160	2320	5,5	0.01
223-12296-8	CUTTING SLEEVE ST D 16-S	S	16	10	Steel, galvanized	400	5800	5,6	0.01
223-12296-3	CUTTING SLEEVE ST D 20-S	S	20	13	Steel, galvanized	400	5800	11,4	0.03
223-12296-5	CUTTING SLEEVE ST D 30-S	S	30	13	Steel, galvanized	400	5800	19,3	0.04
Stainless steel									
223-13639-5	CUTTING SLEEVE VA D 4-LL	LL	4	6	Stainless steel	100	1450	0,3	0.00
223-13639-3	CUTTING SLEEVE VA D 6-L/S	L/S	6	9,5	Stainless steel	250	3625	1	0.00
223-13639-2	CUTTING SLEEVE VA D 6-LL	LL	6	7	Stainless steel	100	1450	0,8	0.00
223-13639-1	CUTTING SLEEVE VA D 8-L/S	L/S	8	9,5	Stainless steel	250	3625	1,7	0.00
223-13639-4	CUTTING SLEEVE VA D 10-L/S	L/S	10	9,5	Stainless steel	250	3625	3,1	0.01
223-13639-9	CUTTING SLEEVE VA D 12-L/S	L/S	12	10	Stainless steel	250	3625	3,5	0.01
223-13639-7	CUTTING SLEEVE VA D 16-S	S	16	9,5	Stainless steel	400	5800	5,6	0.01
223-13639-8	CUTTING SLEEVE VA D 20-S	S	20	12,5	Stainless steel	400	5800	11,4	0.03
223-14092-5	CUTTING SLEEVE VA D 30-S	S	30	12,5	Stainless steel	400	5800	19,3	0.04
Zinc-nickel									
406-351	CUTTING SLEEVE ST D 6-LL Z3W	LL	6	7	Zinc-nickel	100	1450	1	0.00
408-351	CUTTING SLEEVE ST D 8-LL Z3W	LL	8	7	Zinc-nickel	100	1450	1	0.00
406-361	CUTTING SLEEVE ST D 6-L Z3W	LL	6	11,5	Zinc-nickel	250	3625	2	0.00
408-361	CUTTING SLEEVE ST D 8-L Z3W	LL	8	11,5	zinc-nickel	250	3625	2	0.00

Double-edged cutting sleeve unions

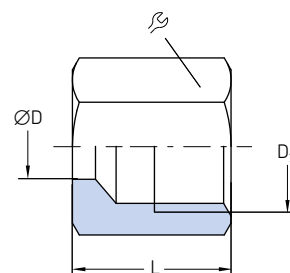
Union nuts M
acc. to DIN 3861/ISO 8434-1

Order number	Designation	Series	Tube		L	Ø	Material	Operating pressure max.		Weight	
			ØD	D ₁				bar	psi	g	lb
Steel, galvanized											
223-13032-1	COUPLING NUT ST M 4-LL CF	LL	4	M8×1	11	10	Steel, galvanized	100	1 450	4	0.01
223-12374-9	COUPLING NUT ST M 6-LL CF	LL	6	M10×1	12	12	Steel, galvanized	100	1 450	6	0.01
223-13032-3	COUPLING NUT ST M 8-LL CF	LL	8	M12×1	12	14	Steel, galvanized	100	1 450	7	0.02
223-12374-6	COUPLING NUT ST M 10-LL CF	LL	10	M14×1	12,5	17	Steel, galvanized	100	1 450	11	0.02
223-12373-9	COUPLING NUT ST M 6-L CF	L	6	M12×1,5	14,5	14	Steel, galvanized	250	3 625	10	0.02
223-13032-4	COUPLING NUT ST M 8-L CF	L	8	M14×1,5	14,5	17	Steel, galvanized	250	3 625	15	0.03
223-13032-6	COUPLING NUT ST M 10-L CF	L	10	M16×1,5	16	19	Steel, galvanized	250	3 625	18	0.04
223-12373-2	COUPLING NUT ST M 12-L CF	L	12	M18×1,5	16	22	Steel, galvanized	250	3 625	25	0.06
223-12374-8	COUPLING NUT ST M 15-L CF	L	15	M22×1,5	18	27	Steel, galvanized	250	3 625	42	0.09
223-12374-7	COUPLING NUT ST M 18-L CF	L	18	M26×1,5	18	32	Steel, galvanized	250	3 625	62	0.14
223-13032-9	COUPLING NUT ST M 16-S CF	S	16	M24×1,5	20,5	30	Steel, galvanized	400	5 800	66	0.15
223-12373-6	COUPLING NUT ST M 20-S CF	S	20	M30×2	24	36	Steel, galvanized	400	5 800	102	0.22
223-12374-2	COUPLING NUT ST M 30-S CF	S	30	M42×2	29	50	Steel, galvanized	400	5 800	219	0.48
Zinc-nickel											
406-352	COUPLING NUT ST M 6-LL Z3W	LL	6	M10×1	11,5	12	Zinc-nickel	100	1 450	5	0.01
408-352	COUPLING NUT ST M 8-LL Z3W	LL	8	M12×1	12	14	Zinc-nickel	100	1 450	5	0.01
406-362	COUPLING NUT ST M 6-L Z3W	S	6	M12×1,5	14,5	14	Zinc-nickel	250	3 625	30	0.07
408-362	COUPLING NUT ST M 8-L Z3W	S	8	M14×1,5	14,5	17	Zinc-nickel	250	3 625	35	0.08
406-362	COUPLING NUT ST M 6-L Z3W	S	6	M12×1,5	14,5	14	Zinc-nickel	250	3 625	30	0.07
408-362	Coupling nut ST M 8-L Z3W	S	8	M14×1,5	14,5	17	Zinc-nickel	250	3 625	35	0.08
Stainless steel											
223-13638-6	COUPLING NUT VA M 4-LL	LL	4	M8×1	11	10	Stainless steel	100	1 450	4	0.01
223-13638-2	COUPLING NUT VA M 6-LL	LL	6	M10×1	12	12	Stainless steel	100	1 450	6	0.01
223-14082-5	COUPLING NUT VA M 6-L	L	6	M12×1,5	14,5	14	Stainless steel	250	3 625	10	0.02
223-13638-1	COUPLING NUT VA M 8-L	L	8	M14×1,5	14,5	17	Stainless steel	250	3 625	15	0.03
223-13638-3	COUPLING NUT VA M 10-L	L	10	M16×1,5	16	19	Stainless steel	250	3 625	18	0.04
223-14082-3	COUPLING NUT VA M 12-L	L	12	M18×1,5	16	22	Stainless steel	250	3 625	25	0.06
223-13638-7	COUPLING NUT VA M 16-S	S	16	M24×1,5	20,5	30	Stainless steel	400	5 800	66	0.15
223-13638-9	COUPLING NUT VA M 20-S	S	20	M30×2	24	36	Stainless steel	400	5 800	102	0.22
223-14082-6	COUPLING NUT VA M 30-S	S	30	M42×2	29	50	Stainless steel	400	5 800	219	0.48

Double-edged cutting sleeve unions

Straight screw-in connectors GE with metrical thread

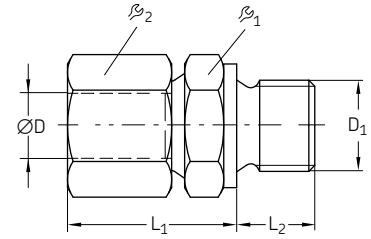

Order number	Designation	Series	Tube		L ₁	L ₂	β ₁	β ₂	Material	Operating pressure max.		Weight	
			ØD	D ₁						bar	psi	g	lb
Cylindrical thread													
223-10263-8	FITTING ST GE 6 -L M10X1 CF	L	6	M10×1	23	8	14	14	Steel, galvanized	315	4 570	40	0.09
223-12361-6	FITTING ST GE 6 -L M14X1.5 CF	L	8	M12×1,5	25	12	17	17	Steel, galvanized	315	4 570	40	0.09
223-14129-4	FITTING ST GE 8 -L M12X1.5 CF	L	10	M14×1,5	26	12	19	19	Steel, galvanized	315	4 570	50	0.11
223-10313-2	FITTING ST GE 10-L M14X1.5 CF	L	10	M18×1,5	27	12	24	19	Steel, galvanized	315	4 570	71	0.16
412-423	FITTING ST GE 10-L M18X1.5 CF	L	12	M14×1,5	26	12	19	22	Steel, galvanized	315	4 570	60	0.13
412-403	FITTING ST GE 12-L M14X1.5 CF	L	12	M16×1,5	27	12	22	22	Steel, galvanized	315	4 570	70	0.15
412-433	FITTING ST GE 12-L M16X1.5 CF	L	12	M18×1,5	27	12	24	22	Steel, galvanized	315	4 570	77	0.17
415-403	FITTING ST GE 12-L M18X1.5 CF	L	15	M18×1,5	29	12	24	27	Steel, galvanized	250	3 626	97	0.21
415-413	FITTING ST GE 15-L M18X1.5 CF	L	15	M22×1,5	30	14	27	27	Steel, galvanized	250	3 626	100	0.22
418-403	FITTING ST GE 15-L M22X1.5 CF	L	18	M22×1,5	31	14	27	32	Steel, galvanized	250	3 626	143	0.32
223-11242-5	FITTING ST GE 18-L M22X1.5 CF	L	18	M18×1,5	30	12	27	32	Steel, galvanized	250	3 626	150	0.33
223-11242-4	FITTING ST GE 18-L M18X1.5 CF	L	22	M27×2	33	16	32	36	Steel, galvanized	160	2 320	160	0.35
223-14214-8	FITTING ST GE 22-L M27X2 CF	L	28	M33×2	34	18	41	41	Steel, galvanized	160	2 320	280	0.62
96-0335-0058	FITTING ST GE 28-L M33X2 CF	L	35	M42×2	39	20	50	50	Steel, galvanized	160	2 320	450	0.99
96-0342-0058	FITTING ST GE 35-L M42X2 CF	L	42	M48×2	42	22	55	60	Steel, galvanized	160	2 320	600	1.32
96-1206-0058	FITTING ST GE 42-L M48X2 CF	S	6	M12×1,5	28	12	17	17	Steel, galvanized	800	11 600	30	0.07
408-413	FITTING ST GE 8 -S M14×1.5 CF	S	8	M14×1,5	30	12	19	17	Steel, galvanized	800	11 600	66	0.15
410-413	FITTING ST GE 10-S M16×1.5 CF	S	10	M16×1,5	31	12	22	22	Steel, galvanized	800	11 600	87	0.19
412-453	FITTING ST GE 12-S M18×1.5 CF	S	12	M18×1,5	33	12	24	24	Steel, galvanized	630	9 140	111	0.24
96-1214-0058	FITTING ST GE 14-S M20×1.5 CF	S	14	M20×1,5	37	14	27	17	Steel, galvanized	630	9 140	140	0.31
Tapered thread													
223-12533-5	FITTING ST GE 4-LLM 6X1 K CF	LL	4	M6×1 tap.	26	8	9	10	Steel, galvanized	100	1 450	12	0.03
223-12271-8	FITTING ST GE 4-LLM 8X1 K CF	LL	4	M8×1 tap.	26	8	10	10	Steel, galvanized	100	1 450	15	0.03
223-13069-1	FITTING ST GE 4-LLM 10X1 K CF	LL	4	M10×1 tap.	26	8	10	10	Steel, galvanized	100	1 450	16	0.04
223-12533-9	FITTING ST GE 6-LLM 6X1 K CF	LL	6	M6×1 tap.	26	8	11	12	Steel, galvanized	100	1 450	19	0.04
223-13023-1	FITTING ST GE 6-LLM 8X1 K CF	LL	6	M8×1 tap.	26	8	11	12	Steel, galvanized	100	1 450	20	0.04
223-12271-7	FITTING ST GE 6-LLM 10X1 K CF	LL	6	M10×1 tap.	26	8	11	12	Steel, galvanized	100	1 450	21	0.05
223-13021-1	FITTING ST GE 8-LLM 10X1 K CF	LL	8	M10×1 tap.	28	8	12	14	Steel, galvanized	100	1 450	24	0.05
410-443	FITTING ST GE 10 -L M10X1 K CF	L	10	M10×1 tap.	25	9	19	17	Steel, galvanized	500	7 250	56	0.12
223-13658-7	FITTING VA GE 6-LLM 6X1 K	LL	6	M6×1 tap.	26	8	11	12	Stainless steel	100	1 450	26	0.06
223-13658-6	FITTING VA GE 6-LLM 8X1 K	LL	6	M8×1 tap.	26	8	11	12	Stainless steel	100	1 450	27	0.06
223-13658-5	FITTING VA GE 6-LM 10X1	LL	6	M10×1 tap.	26	8	11	12	Stainless steel	100	1 450	31	0.07
223-13715-1	FITTING VA GE 6-LLM 10X1 K	LL	8	M10×1 tap.	28	8	12	14	Stainless steel	100	1 450	33	0.07
223-14184-5	FITTING VA GE 8-LLM 10X1 K	L	6	M10×1	23	8	14	14	Stainless steel	100	1 450	31	0.07
410-403-53	FITTING VA GE 10 -L M14X1.5	L	10	M14×1,5	26	12	19	19	Stainless steel	315	4 570	24	0.05

Double-edged cutting sleeve unions

Straight screw-in connectors GE with Whitworth pipe thread

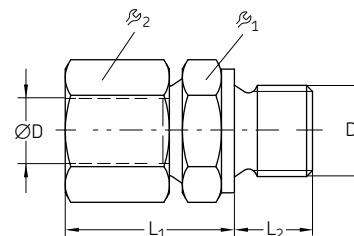

Order number	Designation	Series	Tube		L ₁	L ₂	r ₁	r ₂	Material	Operating pressure max.		Weight	
			ØD	D ₁						bar	psi	g	lb
Cylindrical thread													
223-13016-3	FITTING ST ST GE 6-L G 1/8 CF	L	6	G 1/8	23	8	14	14	Steel, galvanized	315	4 570	18	0.04
223-12477-8	FITTING ST GE 6-L G 1/4 CF	L	6	G 1/4	25	12	19	14	Steel, galvanized	315	4 570	35	0.08
223-13766-6	FITTING ST GE 6-L G 3/8 CF	L	6	G 3/8	26	12	22	14	Steel, galvanized	315	4 570	51	0.11
223-10814-2	FITTING ST GE 8-L G 1/8 CF	L	8	G 1/8	23	8	14	17	Steel, galvanized	315	4 570	24	0.05
223-12477-6	FITTING ST GE 8-L G 1/4 CF	L	8	G 1/4	25	12	19	17	Steel, galvanized	315	4 570	35	0.08
223-10080-3	FITTING ST GE 8-L G 3/8 CF	L	8	G 3/8	26	12	22	17	Steel, galvanized	315	4 570	53	0.12
408-453W	FITTING ST GE 8-L G 1/2 CF	L	8	G 1/2	27	14	27	17	Steel, galvanized	315	4 570	82	0.18
223-12272-9	FITTING ST GE 10-L G 1/4 CF	L	10	G 1/4	26	12	19	19	Steel, galvanized	315	4 570	41	0.09
223-14214-4	FITTING ST GE 10-L G 3/8 CF	L	10	G 3/8	27	12	22	19	Steel, galvanized	315	4 570	55	0.12
223-10313-7	FITTING ST GE 10-L G 1/2 CF	L	10	G 1/2	28	14	27	19	Steel, galvanized	315	4 570	83	0.18
223-12477-9	FITTING ST GE 12-L G 1/4 CF	L	12	G 1/4	27	12	19	22	Steel, galvanized	315	4 570	46	0.10
223-12360-8	FITTING ST GE 12-L G 3/8 CF	L	12	G 3/8	27	12	22	22	Steel, galvanized	315	4 570	56	0.12
412-453W	FITTING ST GE 12-L G 1/2 CF	L	12	G 1/2	28	14	27	22	Steel, galvanized	250	3 625	79	0.17
415-443W	FITTING ST GE 15-L G 3/4 CF	L	15	G 3/4	30	16	32	27	Steel, galvanized	250	3 625	163	0.36
223-12361-9	FITTING ST GE 15-L G 1/2 CF	L	15	G 1/2	29	14	27	27	Steel, galvanized	250	3 625	119	0.26
223-13621-8	FITTING ST GE 15-L G 3/8 CF	L	15	G 3/8	29	12	24	27	Steel, galvanized	250	3 625	101	0.22
223-13766-1	FITTING ST GE 18-L G 1/2 CF	L	18	G 1/2	31	14	27	32	Steel, galvanized	250	3 625	139	0.31
418-413W	FITTING ST GE 18-L G 3/4 CF	L	18	G 3/4	30	16	32	32	Steel, galvanized	250	3 625	178	0.39
223-13749-3	FITTING ST GE 22-L G 1/2 CF	L	22	G 1/2	33	14	32	36	Steel, galvanized	160	2 320	180	0.40
223-13016-2	FITTING ST GE 22-L G 3/4 CF	L	22	G 3/4	33	16	32	36	Steel, galvanized	160	2 320	191	0.42
223-14214-9	FITTING ST GE 28-L G 3/4 CF	L	28	G 3/4	34	16	41	41	Steel, galvanized	160	2 320	257	0.57
223-13610-9	FITTING ST GE 28-L G 1 CF	L	28	G 1	34	18	41	41	Steel, galvanized	160	2 320	287	0.63
223-12477-1	FITTING ST GE 6-S G 1/4 CF	S	6	G 1/4	28	12	19	17	Steel, galvanized	400	5 800	54	0.12
223-12477-2	FITTING ST GE 8-S G 1/4 CF	S	8	G 1/4	30	12	19	19	Steel, galvanized	400	5 800	60	0.13
223-13016-6	FITTING ST GE 8-S G 3/8 CF	S	8	G 3/8	30	12	22	19	Steel, galvanized	400	5 800	78	0.17
223-13016-9	FITTING ST GE 10-S G 1/4 CF	S	10	G 1/4	31	12	19	22	Steel, galvanized	400	5 800	77	0.17
223-13016-4	FITTING ST GE 10-S G 3/8 CF	S	10	G 3/8	31	12	22	22	Steel, galvanized	400	5 800	90	0.20
223-13016-7	FITTING ST GE 12-S G 3/8 CF	S	12	G 3/8	33	12	22	24	Steel, galvanized	400	5 800	96	0.21
223-14129-3	FITTING ST GE 12-S G 1/2 CF	S	12	G 1/2	24	14	27	24	Steel, galvanized	400	5 800	91	0.20
96-1114-0058	FITTING ST GE 14-S G 1/2 CF	S	14	G 1/2	27	14	27	27	Steel, galvanized	400	5 800	153	0.34
223-13749-5	FITTING ST GE 16-S G 3/8 CF	S	16	G 3/8	36	12	27	30	Steel, galvanized	400	5 800	165	0.36
223-13621-1	FITTING ST GE 16-S G 1/2 CF	S	16	G 1/2	37	14	27	30	Steel, galvanized	400	5 800	164	0.36
223-12360-6	FITTING ST GE 20-S G 1/2 CF	S	20	G 1/2	42	14	32	36	Steel, galvanized	400	5 800	214	0.47
223-12359-6	FITTING ST GE 20-S G 3/4 CF	S	20	G 3/4	42	16	32	32	Steel, galvanized	400	5 800	224	0.49
223-14214-2	FITTING ST GE 6-L 1/8NPT CF	L	6	1/8 NPT	32	10	11	12	Steel, galvanized	100	1 450	24	0.05
223-12273-5	FITTING ST GE 8-L 1/4NPT CF	L	8	1/4 NPT	38	14.5	17	17	Steel, galvanized	315	4 570	42	0.09
223-13096-2	FITTING ST GE 10-S 1/4NPT CF	S	10	1/4 NPT	44	14.5	19	22	Steel, galvanized	630	9 140	77	0.17
223-14214-5	FITTING ST GE 10-S 1/2NPT CF	S	20	1/2 NPT	59	19.5	32	36	Steel, galvanized	400	5 800	235	0.52
223-14214-2	FITTING ST GE 6-L 1/8NPT CF	L	6	1/8 NPT	32	10	11	12	Steel, galvanized	100	1 450	24	0.05
223-12273-5	FITTING ST GE 8-L 1/4NPT CF	L	8	1/4 NPT	38	14.5	17	17	Steel, galvanized	315	4 570	42	0.09
223-13096-2	FITTING ST GE 10-S 1/4NPT CF	S	10	1/4 NPT	44	14.5	19	22	Steel, galvanized	630	9 140	77	0.17
223-14214-5	FITTING ST GE 20-S 1/2NPT CF	S	20	1/2 NPT	59	19.5	32	36	Steel, galvanized	400	5 800	235	0.52
Tapered thread													
223-12270-8	FITTING ST GE 4-LL R 1/8K CF	LL	4	R 1/8	26	8	11	10	Steel, galvanized	100 ¹⁾	1 450 ¹⁾	12	0.03
223-12270-7	FITTING ST GE 6-LL R 1/8K CF	LL	6	R 1/8	26	8	11	12	Steel, galvanized	100 ¹⁾	1 450 ¹⁾	15	0.03
223-12270-9	FITTING ST GE 8-LL R 1/8K CF	LL	8	R 1/8	28	8	12	14	Steel, galvanized	100 ¹⁾	1 450 ¹⁾	18	0.04
223-13621-6	FITTING ST GE 8-LL R 1/4K CF	LL	8	R 1/4	32	12	14	14	Steel, galvanized	100 ¹⁾	1 450 ¹⁾	26	0.06
96-5911-0058	FITTING ST GE 10-LL R 1/4K CF	LL	10	R 1/4	32	12	14	17	Steel, galvanized	100 ¹⁾	1 450 ¹⁾	36	0.08
96-5912-0058	FITTING ST GE 12-LL R 1/4K CF	LL	12	R 1/4	32	12	17	19	Steel, galvanized	100 ¹⁾	1 450 ¹⁾	65	0.14
96-5913-0058	FITTING ST GE 12-LL R 3/8K CF	LL	12	R 3/8	32	12	17	19	Steel, galvanized	100 ¹⁾	1 450 ¹⁾	55	0.12
410-443W	FITTING ST GE 10-L R 1/8K CF	L	10	R 1/8	34	8	14	17	Steel, galvanized	315	4 570	42	0.09

¹⁾ In grease lubrication systems fittings are permitted for operating pressures up to 350 bar, 5080 psi

Double-edged cutting sleeve unions

Straight screw-in connectors GE with Whitworth pipe thread, made from stainless steel or brass

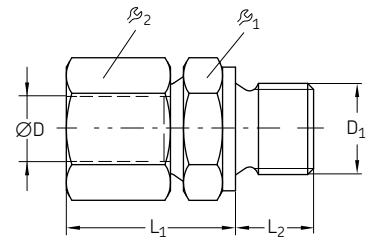

Order number	Designation	Tube Series	ØD		L ₁	L ₂	β ₁	β ₂	Material	Operating pressure max.		Weight	
			mm	mm						bar	psi	g	lb
Stainless steel													
223-13614-9	FITTING ST GE 6-LL R 1/8	LL	6	R 1/8	26	8	11	10	Stainless steel	100	1 450	65	0.14
223-13658-2	FITTING ST GE 6-L G 1/8	L	6	G 1/8	23	8	14	14	Stainless steel	315	4 570	23	0.05
223-13658-9	FITTING ST GE 6-L G 1/4	L	6	G 1/4	25	12	19	14	Stainless steel	315	4 570	40	0.09
223-14420-7	FITTING ST GE 10-L G 1/4	L	10	G 1/4	26	12	19	19	Stainless steel	315	4 570	50	0.11
223-13715-9	FITTING ST GE 15-L G 1/2	L	15	G 1/2	29	14	27	27	Stainless steel	250	3 625	119	0.26
223-13715-6	FITTING ST GE 15-L G 3/8	L	15	G 3/8	29	12	24	27	Stainless steel	250	3 625	88	0.19
223-14420-8	FITTING ST GE 18-L G 1/2	L	18	G 1/2	31	14	27	32	Stainless steel	250	3 625	139	0.31
99-0222-0058	FITTING ST GE 22-L G 3/4	L	22	G 3/4	33	16	32	36	Stainless steel	160	2 320	191	0.42
223-14184-2	FITTING ST GE 28-L G 1	L	28	G 1	34	18	41	41	Stainless steel	160	2 320	278	0.61
223-13614-7	FITTING ST GE 6-S G 1/4	S	6	G 1/4	28	12	19	17	Stainless steel	400	5 800	54	0.12
223-13614-6	FITTING VA GE 8-S G 1/4	S	8	G 1/4	30	12	19	19	Stainless steel	400	5 800	64	0.14
223-12452-9	FITTING VA GE 10-S G 1/4	S	10	G 1/4	31	12	19	22	Stainless steel	400	5 800	77	0.17
223-12452-7	FITTING VA GE 16-S G 1/2	S	16	G 1/2	37	14	27	30	Stainless steel	400	5 800	164	0.36
223-13658-4	FITTING VA GE 20-S G 1/2	S	20	G 1/2	42	14	32	36	Stainless steel	400	5 800	214	0.47
223-12452-5	FITTING VA GE 20-S G 3/4	S	20	G 3/4	42	16	32	32	Stainless steel	400	5 800	224	0.49
Brass													
223-12377-7	FITTING MS GE 8-L G 1/4	L	8	G 1/4	25	12	19	17	Brass	200	2 900	26	0.06
223-12377-8	FITTING MS GE 15-L G 1/2	L	15	G 1/2	29	14	27	27	Brass	160	2 320	72	0.16

Double-edged cutting sleeve unions

Straight screw-in glands XGE

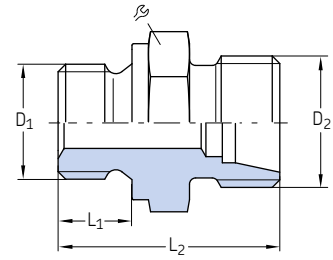

Order number	Designation	Series	Tube		D ₂	L ₁	L ₂	⌀	Material	Operating pressure max.		Weight	
			Ø	D ₁						bar	psi	g	lb
			mm	mm	mm	mm	mm	mm					
223-13766-9	FITTING ST XGE 6-LL M 10X1,0K CF	LL	6	M10×1 tap.	M10×1	8	20	11	Steel, galvanized	100	1 450	17	0.04
223-14129-1	FITTING ST XGE 6-LL M 8X1,0K CF	LL	6	M8×1 tap.	M10×1	8	20	11	Steel, galvanized	100	1 450	17	0.04
223-14129-2	FITTING ST XGE 6-LL R 1/8K CF	LL	6	R 1/8	M12×1,5	8	20	11	Steel, galvanized	100	1 450	18	0.04
223-14234-7	FITTING ST XGE 6-L M 10X1,0 CF	L	6	M10×1	M12×1,5	8	23,5	14	Steel, galvanized	500	7 250	20	0.04
408-313	FITTING ST XGE 8-L M 14X1,5 CF	L	8	M14×1.5	M14×1,5	9	36	17	Steel, galvanized	500	7 250	31	0.07
410-313	FITTING ST XGE10-L M 16X1,5 CF	L	10	M16×1.5	M16×1,5	9	31,5	22	Steel, galvanized	500	7 250	40	0.09
223-14304-2	FITTING ST XGE 10-L M 14X1,5 CF	L	10	M14×1.5	M16×1,5	9	30,0	19	Steel, galvanized	500	7 250	40	0.09
223-14304-7	FITTING ST XGE 12-L M 14X1,5 CF	L	12	M14×1.5	M18×1,5	12	30,0	19	Steel, galvanized	400	5 800	55	0.12
223-13610-8	FITTING ST XGE 18-L M 22X1,5 CF	L	18	M22×1.5	M26×1,5	14	36,0	27	Steel, galvanized	315	4 570	148	0.33
223-11229-9	FITTING ST XGE 8-L G 1/4A CF	L	8	G 1/4	M14×1,5	12	30	19	Steel, galvanized	500	7 250	35	0.08
223-14234-4	FITTING ST XGE10-L G 1/8A CF	L	10	G 1/8	M18×1,5	12	34	17	Steel, galvanized	500	7 250	33	0.07
223-10055-9	FITTING ST XGE10-L G 3/8A CF	L	10	G 3/8	M18×1,5	12	31,5	22	Steel, galvanized	500	7 250	55	0.12
223-14418-7	FITTING ST XGE18-L G 1/2A CF	L	18	G 1/2	M26×1,5	14	36	27	Steel, galvanized	400	5 800	139	0.31
223-11089-3	FITTING ST XGE10-S G 1/4A CF	S	10	G 1/4	M18×1,5	12	30	19	Steel, galvanized	800	11 600	41	0.09
223-14304-5	FITTING ST XGE20-S G 1/2A CF	S	20	G 1/2	M30×2	14	45	32	Steel, galvanized	420	6 090	262	0.58

Straight tube-to-tube connectors G

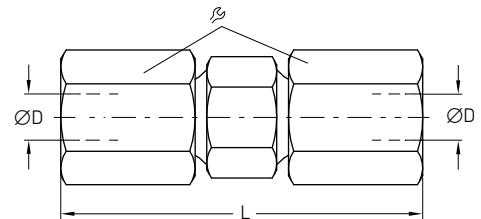

Order number	Designation	Series	Tube ØD		L	⌀	Material	Operating pressure max.		Weight		
			mm	mm				mm	bar	psi	g	lb
Steel, galvanized												
223-12531-8	FITTING ST G 4-LL CF	LL	4	31	10		Steel, galvanized	100	1 450	13	0.03	
223-12482-9	FITTING ST G 6-LL CF	LL	6	32	12		Steel, galvanized	100	1 450	21	0.05	
223-12531-9	FITTING ST G 8-LL CF	LL	8	35	14		Steel, galvanized	100	1 450	26	0.06	
223-12531-2	FITTING ST G 10-L CF	L	10	42	19		Steel, galvanized	500	7 250	65	0.14	
223-13732-8	FITTING ST G 12-L CF	L	12	43	22		Steel, galvanized	500	7 250	84	0.19	
223-12531-6	FITTING ST G 15-L CF	L	15	46	27		Steel, galvanized	400	5 800	145	0.32	
223-13732-4	FITTING ST G 18-L CF	L	18	48	32		Steel, galvanized	400	5 800	205	0.45	
223-13049-3	FITTING ST G 10-S CF	S	10	49	22		Steel, galvanized	800	11 600	112	0.25	
223-12531-4	FITTING ST G 16-S CF	S	16	57	30		Steel, galvanized	630	9 140	234	0.52	
223-12363-2	FITTING ST G 20-S CF	S	20	66	36		Steel, galvanized	420	6 090	369	0.81	
223-12363-6	FITTING ST G 30-S CF	S	30	80	50		Steel, galvanized	420	6 090	806	1.78	
Stainless steel												
223-13615-5	FITTINGVA G 6-L	L	6	39	14		Stainless steel	315	4 570	36	0.08	
223-13615-3	FITTINGVA G 8-L	L	8	40	17		Stainless steel	315	4 570	50	0.11	
223-13615-6	FITTINGVA G 10-L	L	10	42	19		Stainless steel	315	4 570	37	0.08	
223-12454-8	FITTINGVA G 15-L	L	15	46	27		Stainless steel	315	4 570	145	0.32	
223-12454-1	FITTINGVA G 10-S	S	10	49	22		Stainless steel	630	9 140	112	0.25	
223-12454-6	FITTINGVA G 16-S	S	16	57	30		Stainless steel	400	5 800	234	0.52	
223-12454-3	FITTINGVA G 20-S	S	20	66	36		Stainless steel	400	5 800	369	0.81	
223-12454-5	FITTINGVA G 30-S	S	30	80	50		Stainless steel	400	5 800	806	1.78	

Double-edged cutting sleeve unions

Straight tube-to-tube reducing connectors GR

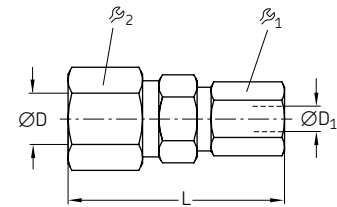

Order number	Designation	Series	Tube	Tube	L	β ₁	β ₂	Material	Operating pressure max.		Weight	
			ØD	ØD ₁		mm	mm		mm	bar	psi	g
Steel, galvanized												
223-12542-2	FITTING ST GR 6/ 4-LL CF	LL	6	4	32	10	12	Steel, galvanized	100	1 450	7	0.02
504-412	FITTING ST GR 8/ 4 L CF	L	8	4	34	10	14	Steel, galvanized	100	1 450	9	0.02
223-13705-5	FITTING ST GR 8/6 L CF	L	8	6	40	14	17	Steel, galvanized	500	7 250	16	0.04
223-13622-3	FITTING ST GR 10/6 L CF	L	10	6	41	14	19	Steel, galvanized	500	7 250	21	0.05
223-13024-4	FITTING ST GR 10/8 L CF	L	10	8	41	17	19	Steel, galvanized	500	7 250	21	0.05
223-10986-1	FITTING ST GR 12/6 L CF	L	12	6	42	14	22	Steel, galvanized	400	5 800	26	0.06
223-13622-7	FITTING ST GR 12/8 L CF	L	12	8	42	17	22	Steel, galvanized	400	5 800	26	0.06
510-410	FITTING ST GR 12/10 L CF	L	12	10	43	19	22	Steel, galvanized	400	5 800	29	0.06
223-13024-8	FITTING ST GR 15/8 L CF	L	15	8	45	17	27	Steel, galvanized	400	5 800	42	0.09
223-12542-7	FITTING ST GR 15/10 L CF	L	15	10	45	19	27	Steel, galvanized	400	5 800	46	0.10
223-12452-8	FITTING ST GR 15/12 L CF	L	15	12	45	22	27	Steel, galvanized	400	5 800	45	0.10
510-413	FITTING ST GR 18/10 L CF	L	18	10	46	19	32	Steel, galvanized	400	5 800	65	0.14
512-412	FITTING ST GR 18/12 L CF	L	18	12	46	22	32	Steel, galvanized	400	5 800	64	0.14
515-410	FITTING ST GR 18/15 L CF	L	18	15	48	27	32	Steel, galvanized	400	5 800	65	0.14
223-13622-1	FITTING ST GR 16/10 S CF	S	16	10	54	22	30	Steel, galvanized	630	9 140	80	0.18
223-12364-4	FITTING ST GR 20/10 S CF	S	20	10	60	22	36	Steel, galvanized	420	6 090	129	0.28
223-13024-1	FITTING ST GR 30/20 S CF	S	30	20	74	36	50	Steel, galvanized	420	6 090	299	0.66
Stainless steel												
223-13619-9	FITTING VA GR 16/10 S	S	16	10	54	22	30	Stainless steel	400	5 800	80	0.18
223-13619-2	FITTING VA GR 20/10 S	S	20	10	60	22	36	Stainless steel	400	5 800	129	0.28
223-13791-5	FITTING VA GR 30/20 S	S	30	20	74	36	50	Stainless steel	400	5 800	299	0.66

Double-edged cutting sleeve unions

Union studs GZ

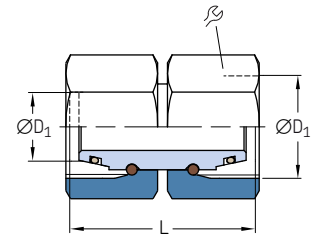

Order number	Designation	Series	Tube ØD D ₁		L	ϕ	Material	Operating pressure max.		Weight	
			mm	mm				bar	psi	g	lb
Steel, galvanized											
223-10550-2	STUD ST GZ 6-L CF	L	6	M14×1,5	33	14	Steel, galvanized	500	7 250	28	0.06
223-10550-8	STUD ST GZ 8-L CF	L	8	M14×1,5	33	17	Steel, galvanized	500	7 250	41	0.09
223-14253-2	STUD ST GZ10-L CF	L	10	M16×1,5	34	19	Steel, galvanized	500	7 250	53	0.12
223-10550-6	STUD ST GZ12-L CF	L	12	M18×1,5	34	22	Steel, galvanized	400	5 800	71	0.16
223-14253-5	STUD ST GZ15-L CF	L	15	M22×1,5	39	27	Steel, galvanized	400	5 800	129	0.28
223-10550-1	STUD ST GZ 6-S CF	S	6	M14×1,5	33	17	Steel, galvanized	800	11 600	41	0.09
223-14253-4	STUD ST GZ10-S CF	S	10	M18×1,5	35	22	Steel, galvanized	800	11 600	74	0.16
223-14253-1	STUD ST GZ16-S CF	S	16	M24×1,5	42	30	Steel, galvanized	630	9 140	172	0.38
223-14497-8	STUD ST GZ20-S CF	S	20	M30×2	48	36	Steel, galvanized	420	6 090	261	0.58
223-14253-3	STUD ST GZ30-S CF	S	30	M42×2	62	50	Steel, galvanized	420	6 090	605	1.33
Stainless steel											
223-14497-1	STUD VA GZ10-L	L	10	M16×1,5	34	19	Stainless steel	315	4 570	53	0.12
223-14497-3	STUD VA GZ16-S	S	16	M24×1,5	42	30	Stainless steel	400	5 800	172	0.38
223-14497-4	STUD VA GZ20-S	S	20	M30×2	48	36	Stainless steel	400	5 800	261	0.58

Straight tube studs EGE

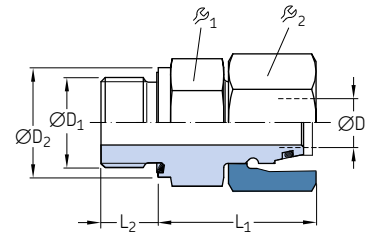

Order number	Designation	Series	Tube		ØD ₂	L ₁	L ₂	ϕ ₁	ϕ ₂	Material	Operating pressure max.		Weight	
			ØD	ØD ₁							mm	mm	mm	mm
223-14130-7	TUBE STUD ST EGE 6-L G 1/8-ED CF	L	6	G 1/8	14	24,5	8	14	14	Steel, galvanized	500	7 250	27	0.06
223-13686-1	TUBE STUD ST EGE10-L G 1/4-ED CF	L	10	G 1/4	19	27,5	12	19	19	Steel, galvanized	500	7 250	54	0.12
223-14130-9	TUBE STUD ST EGE10-L G 3/8-ED CF	L	10	G 3/8	22	29	12	22	19	Steel, galvanized	400	5 800	70	0.15
223-14187-4	TUBE STUD ST EGE10-L M14×1.5-ED CF	L	10	M14×1,5	19	27,5	12	19	19	Steel, galvanized	500	7 250	49	0.11
223-10563-8	TUBE STUD ST EGE12-L M16×1.5-ED CF	L	12	M16×1,5	22	30,5	12	22	22	Steel, galvanized	400	5 800	67	0.15
223-14187-4	TUBE STUD ST EGE10-L 1/4 NPT-ED CF	L	10	1/4 NPT	19	27,5	12	19	19	Steel, galvanized	315	4 570	44	0.10
223-10563-5	TUBE STUD ST EGE12-L G 1/4-ED CF	L	12	G 1/4	19	27,5	12	19	22	Steel, galvanized	400	5 800	61	0.13
223-14130-2	TUBE STUD ST EGE15-L G 1/2-ED CF	L	15	G 1/2	27	32	14	27	27	Steel, galvanized	400	5 800	114	0.25
223-10563-7	TUBE STUD ST EGE 6-S G 1/4-ED CF	S	6	G 1/4	19	27	12	19	17	Steel, galvanized	800	11 600	53	0.12
223-10563-6	TUBE STUD ST EGE12-S G 3/8-ED CF	S	12	G 3/8	22	34	12	22	24	Steel, galvanized	630	9 140	95	0.21
223-14130-2	TUBE STUD ST EGE30-S 3/4 NPT-ED CF	S	20	3/4 NPT	32	43	16	32	36	Steel, galvanized	400	5 800	254	0.56

Double-edged cutting sleeve unions

T-connectors T

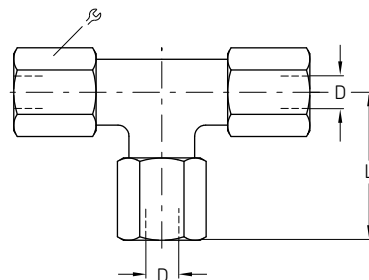

Order number	Designation	Series	Tube			Material	Operating pressure max.		Weight	
			ØD	L	ψ		bar	psi	g	lb
			mm	mm	mm					
Steel, galvanized										
223-12563-5	FITTING ST T 4-LL CF	LL	4	21	10	Steel, galvanized	100	1 450	31	0.07
223-12484-2	FITTING ST T 6-L CF	L	6	27	14	Steel, galvanized	500	7 250	58	0.13
223-12484-6	FITTING ST T 8-L CF	L	8	29	17	Steel, galvanized	500	7 250	104	0.23
223-13057-5	FITTING ST T 10-L CF	L	10	30	19	Steel, galvanized	500	7 250	111	0.24
412-407	FITTING ST T 12-L CF	L	12	32	22	Steel, galvanized	400	5 800	149	0.33
223-12563-2	FITTING ST T 15-L CF	L	15	36	27	Steel, galvanized	400	5 800	247	0.54
418-407	FITTING ST T 18-L CF	L	18	40	32	Steel, galvanized	400	5 800	383	0.84
223-13057-4	FITTING ST T 22-L CF	L	22	44	36	Steel, galvanized	250	3 625	492	1.08
223-12563-9	FITTING ST T 10-S CF	S	10	34	22	Steel, galvanized	800	11 600	193	0.43
223-13057-2	FITTING ST T 16-S CF	S	16	43	30	Steel, galvanized	630	9 140	418	0.92
223-12366-2	FITTING ST T 20-S CF	S	20	48	36	Steel, galvanized	420	6 090	867	1.91
223-12366-6	FITTING ST T 30-S CF	S	30	62	50	Steel, galvanized	420	6 090	2 274	5.01
Stainless steel										
223-13616-3	FITTING VAT 10-L	L	10	30	19	Stainless steel	315	4 570	111	0.24
223-12455-1	FITTING VAT 10-S	S	10	34	22	Stainless steel	630	9 140	193	0.43
223-12455-5	FITTING VAT 16-S	S	16	43	30	Stainless steel	400	5 800	418	0.92
223-12455-2	FITTING VAT 20-S	S	20	48	36	Stainless steel	400	5 800	867	1.91

Reducing T-connectors TR

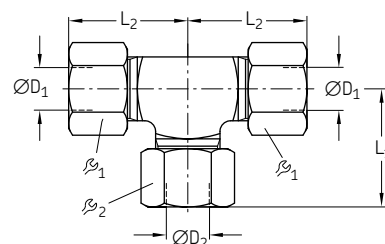

Order number	Designation	Series	Tube		L ₁	L ₂	ψ ₁	ψ ₂	Material	Operating pressure max.		Weight	
			ØD ₁	ØD ₂						bar	psi	g	lb
			mm	mm	mm	mm	mm	mm					
Steel, galvanized													
223-12573-6	FITTING ST TR10/ 6/10-L CF	L	10	6	30	30	19	14	Steel, galvanized	500	7 250	94	0.21
223-12541-5	FITTING ST TR15/10/15-L CF	L	15	10	36	36	27	19	Steel, galvanized	400	5 800	213	0.47
223-13025-6	FITTING ST TR12/10/12-S CF	S	12	10	38	38	24	22	Steel, galvanized	630	9 140	217	0.48
223-12367-2	FITTING ST TR20/10/20-S CF	S	20	10	46	48	36	22	Steel, galvanized	420	6 090	503	1.11
223-12367-4	FITTING ST TR20/12/20-S CF	S	20	12	46	48	36	24	Steel, galvanized	420	6 090	522	1.15
Stainless steel													
223-13672-8	FITTING VA TR18/10/10-L	L	18	10	39	40	32	19	Stainless steel	315	4 570	305	0.67
223-13672-3	FITTING VA TR20/10/20-S	S	20	10	46	48	36	22	Stainless steel	400	5 800	529	1.17

Double-edged cutting sleeve unions

Elbow connectors W

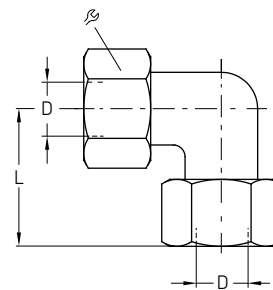

Order number	Designation	Series	Tube ØD		L	⊘	Material	Operating pressure max.		Weight	
			mm	mm				mm	bar	psi	g
Steel, galvanized											
223-12483-2	FITTING ST W 6-L CF	L	6	27	14		Steel, galvanized	500	7 250	41	0.09
223-12483-5	FITTING ST W 8-L CF	L	8	29	17		Steel, galvanized	500	7 250	60	0.13
223-12483-8	FITTING ST W 10-L CF	L	10	30	19		Steel, galvanized	500	7 250	75	0.17
223-12562-2	FITTING ST W 15-L CF	L	15	36	27		Steel, galvanized	400	5 800	128	0.28
443-218-001	FITTING ST W 18-L CF	L	18	40	32		Steel, galvanized	400	5 800	208	0.46
443-290-001	FITTING ST W 22-L CF	L	22	44	36		Steel, galvanized	250	3 625	267	0.59
223-12562-7	FITTING ST W 10-S CF	S	10	34	22		Steel, galvanized	800	11 600	133	0.29
223-12280-9	FITTING ST W 12-S CF	S	12	38	24		Steel, galvanized	630	9 140	175	0.39
223-12562-8	FITTING ST W 16-S CF	S	16	43	30		Steel, galvanized	630	9 140	232	0.51
223-12365-2	FITTING ST W 20-S CF	S	20	48	36		Steel, galvanized	420	6 090	333	0.73
Stainless steel											
223-14424-5	FITTING VAW 8-L	L	8	29	17		Stainless steel	315	4 570	60	0.13
223-13675-6	FITTING VAW 10-S	S	10	34	22		Stainless steel	630	9 140	133	0.29
223-13675-2	FITTING VAW 20-S	S	20	48	36		Stainless steel	400	5 800	333	0.73

Elbow screw-in connectors WE with metrical thread

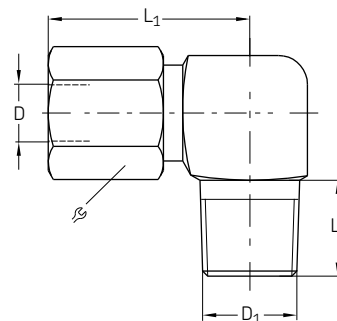

Order number	Designation	Series	Tube		L ₁	L ₂	⊘	Material	Operating pressure max.		Weight	
			ØD	ØD ₁					mm	mm	mm	mm
Steel, galvanized												
223-13023-3	FITTING ST WE 6-LL M8×1K CF	LL	6	M8×1	21	8	12	Steel, galvanized	100	1 450	24	0.05
223-13021-3	FITTING ST WE 6-LL M10×1K CF	LL	6	M10×1	15	8	12	Steel, galvanized	100	1 450	24	0.05
223-12362-4	FITTING ST WE 8-LL M10×1K CF	LL	8	M10×1	17	8	14	Steel, galvanized	100	1 450	33	0.07
223-12485-8	FITTING ST WE 6-L M10×1K CF	L	6	M10×1	19	8	14	Steel, galvanized	315	4 570	41	0.09
223-12362-8	FITTING ST WE 8-L M12×1.5K CF	L	8	M12×1,5	21	12	17	Steel, galvanized	315	4 570	63	0.14
406-405	FITTING ST WE10-L M14×1.5K CF	L	10	M14×1,5	22	12	19	Steel, galvanized	315	4 570	83	0.18
412-405	FITTING ST WE12-L M16×1.5K CF	L	12	M16×1,5	24	12	22	Steel, galvanized	315	4 570	117	0.26
415-405	FITTING ST WE15-L M18×1.5K CF	L	15	M18×1,5	28	12	27	Steel, galvanized	315	4 570	125	0.28
223-12485-2	FITTING ST WE 10-S M16×1.5K CF	S	10	M16×1,5	25	12	22	Steel, galvanized	400	5 800	123	0.27
Stainless steel												
404-405-S3	FITTING VAW E 4-LL M8×1K	LL	4	M8×1	15	8	10	Stainless steel	100	1 450	18	0.04
223-13677-2	FITTING VAW E 6-LL M8×1K	LL	6	M8×1	21	8	12	Stainless steel	100	1 450	24	0.05

Double-edged cutting sleeve unions

Elbow screw-in connectors WE with Whitworth pipe thread

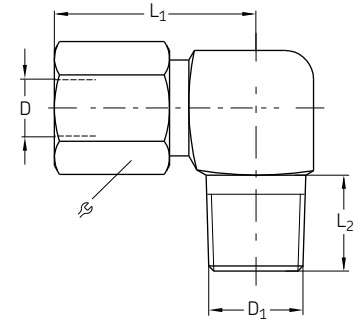

Order number	Designation	Series	Tube		L ₁	L ₂	R	Material	Operating pressure max. Weight			
			∅D	∅D ₁					mm	psi	g	lb
Steel, galvanized												
223-13021-4	FITTING ST WE 4-LL R 1/8K CF	LL	4	R 1/8	15	8	10	Steel, galvanized	100	1 450	21	0.05
223-13021-6	FITTING ST WE 8-LL R 1/8K CF	LL	8	R 1/8	17	8	14	Steel, galvanized	100	1 450	32	0.07
96-6112-0058	FITTING ST WE 12-LL R 1/4K CF	LL	12	R 1/4	19	12	19	Steel, galvanized	100	1 450	61	0.13
223-13048-1	FITTING ST WE 6-L R 1/8K CF	L	6	R 1/8	19	8	14	Steel, galvanized	315	4 570	42	0.09
223-12380-6	FITTING ST WE 6-L R 1/4K CF	L	6	R 1/4	21	12	14	Steel, galvanized	315	4 570	59	0.13
408-425W	FITTING ST WE 8-L R 1/8K CF	L	8	R 1/8	21	8	17	Steel, galvanized	315	4 570	66	0.15
223-14240-5	FITTING ST WE 8-L R 1/4K CF	L	8	R 1/4	21	12	17	Steel, galvanized	315	4 570	63	0.14
223-13048-5	FITTING ST WE 10-L R 1/4K CF	L	10	R 1/4	22	12	19	Steel, galvanized	315	4 570	82	0.18
412-405W	FITTING ST WE 12-L R 3/8K CF	L	12	R 3/8	24	12	22	Steel, galvanized	315	4 570	116	0.26
223-13021-7	FITTING ST WE 15-L R 1/2K CF	L	15	R 1/2	28	14	27	Steel, galvanized	315	4 570	141	0.31
418-405W	FITTING ST WE 18-L R 1/2K CF	L	18	R 1/2	31	14	32	Steel, galvanized	315	4 570	230	0.51
223-13048-6	FITTING ST WE 10-S R 3/8K CF	S	10	R 3/8	25	12	22	Steel, galvanized	400	5 800	138	0.30
96-1412-0058	FITTING ST WE 12-S R 3/8K CF	S	12	R 3/8	29	12	24	Steel, galvanized	400	5 800	164	0.36
223-13048-8	FITTING ST WE 16-S R 1/2K CF	S	16	R 1/2	33	14	30	Steel, galvanized	400	5 800	232	0.51
Stainless steel												
223-13620-8	FITTING VA WE 6-L R 1/8K	L	6	R 1/8	19	8	14	Stainless steel	315	4 570	42	0.09
223-13677-5	FITTING VA WE 8-L R 1/4K	L	8	R 1/4	21	12	17	Stainless steel	315	4 570	63	0.14
223-12453-1	FITTING VA WE 10-L R 1/4K	L	10	R 1/4	22	12	19	Stainless steel	315	4 570	82	0.18

Double-edged cutting sleeve unions

K-connectors K

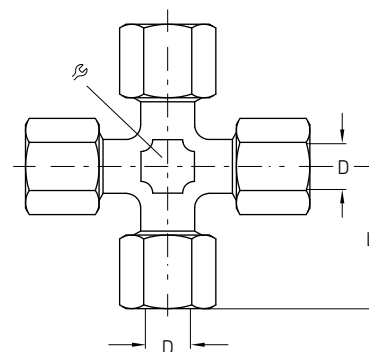

Order number	Designation	Series	Tube Ø		L	Material	Operating pressure max.		Weight	
			mm	mm			bar	psi	g	lb
96-2106-0058	FITTING ST K 6-LL CF	LL	6	21	12	Steel, galvanized	100	1 450	27	0.06
446-308-001	FITTING ST K 8-LL CF	LL	8	23	14	Steel, galvanized	100	1 450	52	0.11
446-310-001	FITTING ST K10-LL CF	LL	10	30	19	Steel, galvanized	100	1 450	110	0.24
446-312-001	FITTING ST K12-LL CF	LL	12	32	22	Steel, galvanized	100	1 450	129	0.28
446-315-001	FITTING ST K15-LL CF	LL	15	36	27	Steel, galvanized	100	1 450	306	0.67
96-2118-0058	FITTING ST K18-L CF	L	18	40	32	Steel, galvanized	160	2 320	420	0.93
96-2122-0058	FITTING ST K22-LL CF	L	22	44	36	Steel, galvanized	160	2 320	550	1.21
223-12423-7	FITTING ST K10-L CF	L	10	30	19	Steel, galvanized	315	4 570	136	0.30
223-12432-2	FITTING ST K10-S CF	S	10	34	22	Steel, galvanized	630	9 140	233	0.51
223-12432-8	FITTING ST K20-S CF	S	20	48	36	Steel, galvanized	315	4 570	791	1.74

Double-edged cutting sleeve unions

Female connector straight GAI with mechanical thread

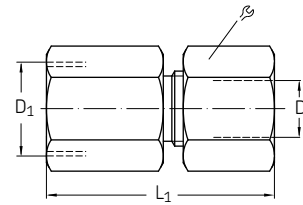

Order number	Designation	Series	Tube		L ₁	L ₂	R	Material	Operating pressure max. Weight			
			∅D	∅D ₁					mm	mm	bar	psi
223-10307-2	FITTING ST GAI 6-L M10×1.0 CF	L	6	M10×1	26,5	19,5	14	Steel, galvanized	315	4 570	30	0.07
96-0508-0060	FITTING ST GAI 8-L M12×1.5 CF	L	8	M12×1,5	31	24	17	Steel, galvanized	315	4 570	49	0.11
223-13033-2	FITTING ST GAI10-L M14×1,5 CF	L	10	M14×1,5	32	25	19	Steel, galvanized	315	4 570	60	0.13
96-0512-0060	FITTING ST GAI12-L M16×1,5 CF	L	12	M16×1,5	33	26	22	Steel, galvanized	315	4 570	80	0.18
223-13693-9	FITTING ST GAI18-L M22×1,5 CF	L	18	M22×1,5	37	29,5	32	Steel, galvanized	315	4 570	179	0.39
96-0606-0060	FITTING ST GAI 6-S M12×1,5 CF	S	6	M12×1	33	26	17	Steel, galvanized	400	5 800	54	0.12
96-0608-0060	FITTING ST GAI 8-S M14×1,5 CF	S	8	M14×1,5	33	26	19	Steel, galvanized	400	5 800	73	0.16

Female connector straight GAI with Whitworth pipe thread

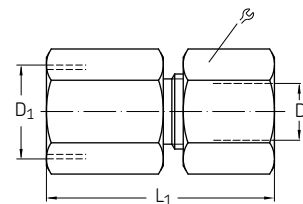

Order number	Designation	Series	Tube		L ₁	L ₂	R	Material	Operating pressure max. Weight			
			∅D	∅D ₁					mm	mm	mm	mm
Steel, galvanized												
223-13693-4	FITTING ST GAI 6-L G1/8 CF	L	6	G1/8	26	19	14	Steel, galvanized	315	4 570	30	0.07
223-13693-6	FITTING ST GAI 8-L G1/4 CF	L	8	G1/4	31	24	19	Steel, galvanized	315	4 570	56	0.12
223-13693-2	FITTING ST GAI10-L G1/4 CF	L	10	G1/4	32	25	19	Steel, galvanized	315	4 570	61	0.13
223-13693-1	FITTING ST GAI10-L G3/8 CF	L	10	G3/8	33	26	24	Steel, galvanized	315	4 570	84	0.19
96-0712-0060	FITTING ST GAI12-L G3/8 CF	L	12	G3/8	33	26	24	Steel, galvanized	315	4 570	92	0.20
96-0715-0060	FITTING ST GAI15-L G1/2 CF	L	15	G1/2	38	31	27	Steel, galvanized	315	4 570	134	0.30
96-0718-0060	FITTING ST GAI18-L G1/2 CF	L	18	G1/2	38	30,5	27	Steel, galvanized	315	4 570	157	0.35
223-12273-2	FITTING ST GAI22-L G3/4 CF	L	22	G3/4	43	35,5	36	Steel, galvanized	160	2 320	262	0.58
Stainless steel												
223-14116-2	FITTING VA GAI10-S G3/8 CF	S	10	G3/8	34	26,5	24	Stainless steel	400	5 800	102	0.22
223-14116-9	FITTING VA GAI20-S G3/4 CF	S	20	G3/4	45	34,5	36	Stainless steel	315	4 570	309	0.68

Double-edged cutting sleeve unions

Check valves GERV

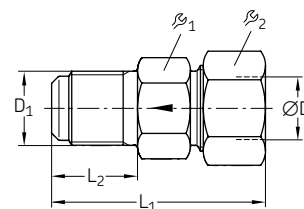

Order number	Designation	Series	Tube		L ₁	L ₂	β ₁	β ₂	Material	Operating pressure max. Weight			
			∅D	∅D ₁						bar	psi	g	lb
Steel, galvanized													
223-12290-2	CHECK VALVE ST GERV 4-LL G 1/8A L CF	LL	4	G 1/8	30	11	10	11	Steel, galvanized	100	1 450	12	0.03
223-12290-7	CHECK VALVE ST GERV 6-LL G 1/8A L CF	LL	6	G 1/8	30	11	12	11	Steel, galvanized	100	1 450	16	0.04
223-13052-8	CHECK VALVE ST GERV 6-LL M10x1 L CF	LL	6	M0x1	30	11	12	11	Steel, galvanized	100	1 450	15	0.03
223-13051-1	CHECK VALVE ST GERV 8-L G 1/4A L CF	L	8	G 1/4	42	14	17	17	Steel, galvanized	400	5 800	45	0.10
223-13051-2	CHECK VALVE ST GERV10 -L G 1/4A L CF	L	10	G 1/4	41	14	19	19	Steel, galvanized	400	5 800	60	0.13
223-12372-9	CHECK VALVE ST GERV 6-S G 1/4A L CF	S	6	G 1/4	44	14	17	17	Steel, galvanized	420	6 090	60	0.13
Stainless steel													
223-12535-9	CHECK VALVE VA GERV 6-LL G 1/8A L	LL	6	G 1/8	30	11	12	11	Stainless steel	100	1 450	16	0.04
223-11185-1	CHECK VALVE VA GERV 6-S G 1/4A L	S	6	G 1/4	44	14	17	17	Stainless steel	400	5 800	60	0.13
223-12535-5	CHECK VALVE VA GERV 8-S G 1/4A L	S	8	G 1/4	42	14	19	19	Stainless steel	400	5 800	45	0.10

Check valves RHV

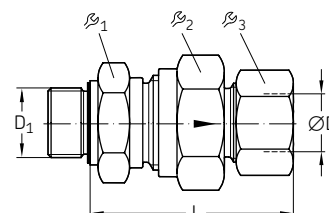

Order number	Designation	Series	Tube		L	β ₁	β ₂	β ₃	Material	Operating pressure max. Weight			
			∅D	∅D ₁						mm	mm	mm	mm
Steel, galvanized													
223-14464-9	CHECK VALVE ST RHV 6-L G 1/8AV CF	L	6	G 1/8	42,5	17	17	14	Steel, galvanized	400	5 800	59	0.13
223-13079-1	CHECK VALVE ST RHV 8-L G 1/4AV CF	L	8	G 1/4	44,5	19	19	17	Steel, galvanized	400	5 800	89	0.20
223-12291-4	CHECK VALVE ST RHV10-L G 1/4AV CF	L	10	G 1/4	53	22	24	19	Steel, galvanized	400	5 800	126	0.28
223-12429-1	CHECK VALVE ST RHV 6-S G 1/4AV CF	S	6	G 1/4	46	19	19	17	Steel, galvanized	420	6 090	82	0.18
223-12291-2	CHECK VALVE ST RHV 8-S G 1/4AV CF	S	8	G 1/4	46	19	19	19	Steel, galvanized	420	6 090	102	0.22
223-12291-6	CHECK VALVE ST RHV10-S G 3/8AV CF	S	10	G 3/8	54	22	24	22	Steel, galvanized	420	6 090	166	0.37
Stainless steel													
223-14464-9	CHECK VALVE VA RHV 6-L G 1/8AV	L	6	G 1/8	42,5	17	17	14	Stainless steel	250	3 625	59	0.13
223-13681-1	CHECK VALVE VA RHV 8-L G 1/4AV	L	8	G 1/4	44,5	19	19	17	Stainless steel	250	3 625	89	0.20
223-13684-2	CHECK VALVE VA RHV 6-S G 1/4AV	S	6	G 1/4	46	19	19	17	Stainless steel	400	5 800	82	0.18

Double-edged cutting sleeve unions

Check valves RHZ

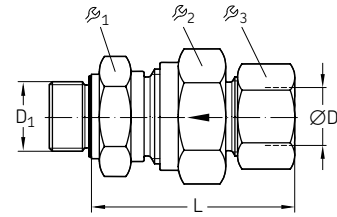

Order number	Designation	Tube Series	ØD	ØD ₁	L	R ₁	R ₂	R ₃	Material	Operating pressure max.		Weight	
										bar	psi	g	lb
			mm	mm	mm	mm	mm	mm					
Steel, galvanized													
223-12292-2	CHECK VALVE ST RHZ 6-L G 1/8A-ED L CF	L	6	G 1/8	41	17	17	14	Steel, galvanized	400	5 800	51	0.11
223-12292-5	CHECK VALVE ST RHZ10-L G 1/4A L CF	L	10	G 1/4	53	22	24	19	Steel, galvanized	400	5 800	148	0.33
223-13706-3	CHECK VALVE ST RHZ 6-L M10×1.0 L CF	L	6	M10×1	41	17	17	14	Steel, galvanized	400	5 800	51	0.11
223-12292-9	CHECK VALVE ST RHZ 6-S G 1/4A L CF	S	6	G 1/4	46	19	19	17	Steel, galvanized	420	6 090	80	0.18
Stainless steel													
223-13692-3	CHECK VALVE VA RHZ 6-L G 1/8A L	L	6	G 1/8	41	17	17	14	Stainless steel	250	3 625	51	0.11

Check valves RHD

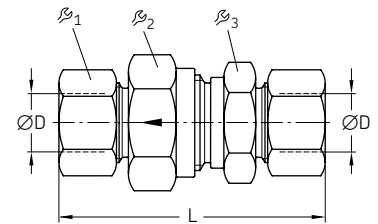

Order number	Designation	Tube Series	ØD	L	R ₁	R ₂	R ₃	Material	Operating pressure max.		Weight	
									bar	psi	g	lb
			mm	mm	mm	mm	mm					
Steel, galvanized												
223-13643-8	CHECK VALVE ST RHD 6-L CF	L	6	58	17	17	14	Steel, galvanized	400	5 800	70	0.15
223-13643-3	CHECK VALVE ST RHD 8-L CF	L	8	59	19	19	17	Steel, galvanized	400	5 800	95	0.21
223-13643-2	CHECK VALVE ST RHD10-L CF	L	10	69,5	22	24	19	Steel, galvanized	400	5 800	146	0.32
223-14464-1	CHECK VALVE ST RHD18-L CF	L	18	83,5	36	36	32	Steel, galvanized	400	5 800	428	0.94
223-13643-1	CHECK VALVE ST RHD10-S CF	S	10	72,5	22	24	22	Steel, galvanized	420	6 090	189	0.42
223-13643-4	CHECK VALVE ST RHD16-S CF	S	16	86,5	32	36	30	Steel, galvanized	420	6 090	430	0.95
223-13643-6	CHECK VALVE ST RHD20-S CF	S	20	97,5	41	46	36	Steel, galvanized	420	6 090	732	1.61
Stainless steel												
223-13770-6	CHECK VALVE VA RHD 6-L	L	6	58	17	17	14	Stainless steel	250	3 625	70	0.15
223-13770-8	CHECK VALVE VA RHD 8-L	L	8	59	19	19	17	Stainless steel	250	3 625	95	0.21
223-13770-2	CHECK VALVE VA RHD10-S	S	10	72,5	22	24	22	Stainless steel	400	5 800	189	0.42
223-13770-5	CHECK VALVE VA RHD20-S	S	20	97,5	41	46	36	Stainless steel	250	3 625	732	1.61

Double-edged cutting sleeve unions

Straight bulkhead connectors SV

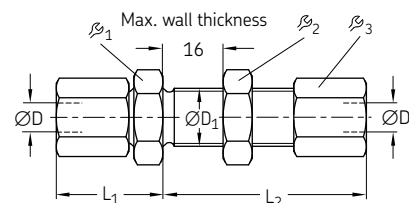

Order number	Designation	Series	Tube		L ₁	L ₂	R ₁	R ₂	R ₃	Material	Operating pressure max.		Weight	
			ØD	ØD ₁							bar	psi	g	lb
Steel, galvanized														
223-12368-4	Fitting ST SV 6-L CF	L	6	12,5	22	42	17	17	14	Steel, galvanized	500	7 250	63	0.14
223-12368-6	Fitting ST SV 8-L CF	L	8	14,5	23	42	19	19	17	Steel, galvanized	500	7 250	84	0.19
223-12368-8	Fitting ST SV 10-L CF	L	10	16,5	25	43	22	22	19	Steel, galvanized	500	7 250	109	0.24
223-13698-4	Fitting ST SV 12-L CF	L	12	18,5	25	44	24	24	22	Steel, galvanized	400	5 800	134	0.30
223-12564-2	Fitting ST SV 15-L CF	L	15	22,5	27	46	27	30	27	Steel, galvanized	400	5 800	222	0.49
223-12564-8	Fitting ST SV 18-L CF	L	18	26,5	30	49	32	36	32	Steel, galvanized	400	5 800	334	0.74
422-416	Fitting ST SV 22-L CF	L	22	30,5	33	51	36	41	36	Steel, galvanized	250	3 625	432	0.95
223-12364-6	Fitting ST SV 10-S CF	S	10	18,5	31	46	24	24	22	Steel, galvanized	800	11 600	180	0.40
223-12368-2	Fitting ST SV 20-S CF	S	20	30,5	39	55	41	41	36	Steel, galvanized	420	6 090	688	1.52
Stainless steel														
223-13671-9	Fitting VA SV 8-S	S	8	16,5	28	44	22	22	19	Stainless steel	630	9 140	133	0.29
223-12564-3	Fitting VA SV 10-S	S	10	18,5	31	46	24	24	22	Stainless steel	630	9 140	180	0.40
223-13671-2	Fitting VA SV 20-S	S	20	30,5	39	55	41	41	36	Stainless steel	400	5 800	688	1.52

Elbow bulkhead connectors WSV

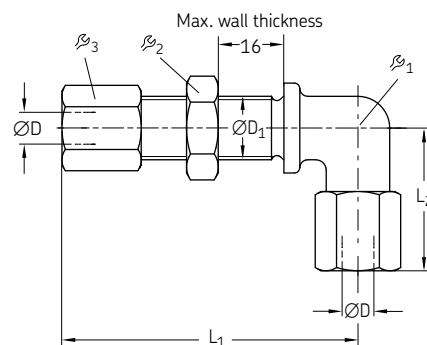

Order number	Designation	Series	Tube		L ₁	L ₂	R ₁	R ₂	R ₃	Material	Operating pressure max.		Weight	
			ØD	ØD ₁							bar	psi	g	lb
Steel, galvanized														
223-13050-4	FITTING ST WSV 6-L CF	L	6	12,5	48	27	12	17	14	Steel, galvanized	315	4 570	75	0.17
223-12409-6	FITTING ST WSV 8-L CF	L	8	14,5	51	29	12	19	17	Steel, galvanized	315	4 570	95	0.21
223-12409-9	FITTING ST WSV 10-L CF	L	10	16,5	53	30	14	22	19	Steel, galvanized	315	4 570	120	0.26
412-409	FITTING ST WSV 12-L CF	L	12	18,5	56	32	17	24	22	Steel, galvanized	315	4 570	141	0.31
223-12409-8	FITTING ST WSV 15-L CF	L	15	22,5	61	36	19	30	27	Steel, galvanized	315	4 570	184	0.41
418-409	FITTING ST WSV 18-L CF	L	18	26,5	64	40	24	36	32	Steel, galvanized	315	4 570	374	0.82
223-13050-3	FITTING ST WSV 22-L CF	L	22	30,5	72	44	27	41	36	Steel, galvanized	160	2 320	505	1.11
223-13050-2	FITTING ST WSV 10-S CF	S	10	18,5	57	34	17	24	22	Steel, galvanized	630	9 140	196	0.43
223-12409-2	FITTING ST WSV 20-S CF	S	20	30,5	74	48	27	41	36	Steel, galvanized	400	5 800	616	1.36
Stainless steel														
223-10364-6	FITTING VA WSV 8-S	S	8	16,5	54	32	14	22	19	Stainless steel	630	9 140	155	0.34
223-10364-3	FITTING VA WSV 10-S	S	10	18,5	57	34	17	24	22	Stainless steel	630	9 140	196	0.43
223-13758-4	FITTING VA WSV 20-S	S	20	30,5	74	48	27	41	36	Stainless steel	400	5 800	616	1.36

Double-edged cutting sleeve unions

Banjo fittings SWVE with metrical thread

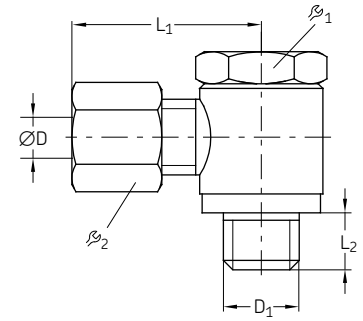

Order number	Designation	Series	Tube		L ₁	L ₂	R ₁	R ₂	Material	Operating pressure max.		Weight	
			∅D	D ₁						bar	psi	g	lb
Steel, galvanized													
223-12480-2	FITTING ST SWVE 4-LL M 8×1 CF	LL	4	M8×1	20	6	12	10	Steel, galvanized	63	915	22	0.05
223-12480-7	FITTING ST SWVE 6-LL M 10×1 CF	LL	6	M10×1	22	6	14	12	Steel, galvanized	63	915	36	0.08
96-7108-0058	FITTING ST SWVE 8-LL M 10×1 CF	LL	8	M10×1	23	6	14	14	Steel, galvanized	63	915	39	0.09
223-12369-7	FITTING ST SWVE 6-L M 10×1 CF	L	6	M10×1	25	6	14	14	Steel, galvanized	160	2 320	43	0.09
96-7808-0058	FITTING ST SWVE 8-L M 12×1.5 CF	L	8	M12×1,5	27	9	17	17	Steel, galvanized	160	2 320	68	0.15
445-535-101	FITTING ST SWVE10-L M 14×1.5 CF	L	10	M14×1,5	29	9	19	19	Steel, galvanized	160	2 320	89	0.20
96-7812-0058	FITTING ST SWVE12-L M 16×1.5 CF	L	12	M16×1,5	30	9	21	22	Steel, galvanized	100	1 450	128	0.28
96-7815-0058	FITTING ST SWVE15-L M 18×1.5 CF	L	15	M18×1,5	33	9	24	27	Steel, galvanized	100	1 450	185	0.41
96-7818-0058	FITTING ST SWVE18-L M 22×1.5 CF	L	18	M22×1,5	37	11	27	32	Steel, galvanized	100	1 450	309	0.68
96-7822-0058	FITTING ST SWVE22-L M 26×1.5 CF	L	22	M26×1,5	42	13	32	36	Steel, galvanized	100	1 450	440	0.97
96-8006-0058	FITTING ST SWVE 6-S M 12×1.5 CF	S	6	M12×1,5	29	9	17	17	Steel, galvanized	160	2 320	74	0.16
96-8008-0058	FITTING ST SWVE 8-S M 14×1.5 CF	S	8	M14×1,5	30	9	19	19	Steel, galvanized	160	2 320	98	0.22
223-13669-4	FITTING ST SWVE10-S M 16×1.5 CF	S	10	M16×1,5	32	9	22	22	Steel, galvanized	100	1 450	140	0.31
96-8012-0058	FITTING ST SWVE12-S M 18×1.5 CF	S	12	M18×1,5	33	9	24	24	Steel, galvanized	100	1 450	172	0.38
96-8014-0058	FITTING ST SWVE14-S M 20×1.5 CF	S	14	M20×1,5	38	11	27	27	Steel, galvanized	100	1 450	236	0.52
96-8016-0058	FITTING ST SWVE16-S M 22×1.5 CF	S	16	M22×1,5	40	11	27	30	Steel, galvanized	100	1 450	324	0.71
Stainless steel													
223-12456-8	FITTING VA SWVE 4-LL M 8×1	LL	4	M8×1	20	6	12	10	Stainless steel	63	915	22	0.05
223-12456-6	FITTING VA SWVE 6-LL M 10×1	LL	6	M10×1	22	6	14	12	Stainless steel	63	915	36	0.08
223-10389-3	FITTING VA SWVE 8-LL M 10×1	LL	8	M10×1	23	6	14	14	Stainless steel	63	915	39	0.09
223-14089-9	FITTING VA SWVE 6-L M 10×1	L	6	M10×1	25	6	14	14	Stainless steel	160	2 320	43	0.09

Double-edged cutting sleeve unions

Banjo fittings SWVE with Whitworth pipe thread

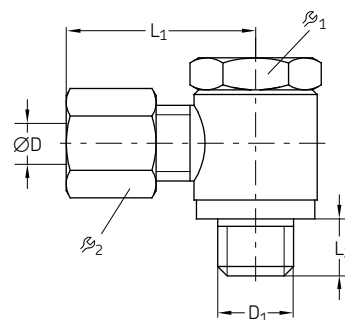

Order number	Designation	Series	Tube		L ₁	L ₂	R ₁	R ₂	Material	Operating pressure max. Weight								
			ØD	D ₁						bar	psi	g	lb					
											mm	mm	mm	mm	mm	mm		
Steel, galvanized																		
223-13629-1	FITTING ST SWVE 4-LL G1/8 CF	LL	4	G 1/8	21	6	14	10	Steel, galvanized	63	915	32	0.07					
223-12479-9	FITTING ST SWVE 6-LL G1/8 CF	LL	6	G 1/8	22	6	14	12	Steel, galvanized	63	915	35	0.08					
223-12479-8	FITTING ST SWVE 8-LL G1/8 CF	LL	8	G 1/8	23	6	14	14	Steel, galvanized	63	915	38	0.08					
223-12479-5	FITTING ST SWVE 6-L G1/8 CF	L	6	G 1/8	25	6	14	14	Steel, galvanized	160	2 320	43	0.09					
223-12284-7	FITTING ST SWVE 8-L G1/4 CF	L	8	G 1/4	28	9	19	17	Steel, galvanized	160	2 320	82	0.18					
223-12369-9	FITTING ST SWVE 10-L G1/4 CF	L	10	G 1/4	29	9	19	22	Steel, galvanized	160	2 320	87	0.19					
223-13669-3	FITTING ST SWVE 12-L G3/8 CF	L	12	G 3/8	30	9	19	22	Steel, galvanized	100	1 450	130	0.29					
445-513-181	FITTING ST SWVE 18-L G1/2 CF	L	18	G 1/2	37	11	27	32	Steel, galvanized	100	1 450	317	0.70					
445-517-222	FITTING ST SWVE 22-L G3/4 CF	L	22	G 3/4	42	13	32	36	Steel, galvanized	100	1 450	438	0.97					
223-12285-8	FITTING ST SWVE 6-S G1/4 CF	S	6	G 1/4	30	9	19	17	Steel, galvanized	160	2 320	88	0.19					
223-12285-9	FITTING ST SWVE 8-S G1/4 CF	S	8	G 1/4	30	9	19	19	Steel, galvanized	160	2 320	96	0.21					
223-12285-5	FITTING ST SWVE 10-S G3/8 CF	S	10	G 3/8	32	9	22	22	Steel, galvanized	100	1 450	142	0.31					
223-12285-6	FITTING ST SWVE 12-S G3/8 CF	S	12	G 3/8	33	9	24	24	Steel, galvanized	100	1 450	185	0.41					
96-7914-0058	FITTING ST SWVE 14-S G1/2 CF	S	14	G 1/2	38	11	27	27	Steel, galvanized	100	1 450	234	0.52					
96-7916-0058	FITTING ST SWVE 16-S G1/2 CF	S	16	G 1/2	40	11	27	30	Steel, galvanized	100	1 450	321	0.71					
223-12285-7	FITTING ST SWVE 20-S G3/4 CF	S	20	G 3/4	46	13	32	36	Steel, galvanized	100	1 450	472	1.04					
Stainless steel																		
223-12456-7	FITTING VA SWVE 6-LL G1/8	LL	6	G 1/8	22	6	14	12	Stainless steel	63	915	35	0.08					
223-10389-4	FITTING VA SWVE 6-S G1/4	L	6	G 1/4	22	9	19	17	Stainless steel	160	2 320	45	0.10					
223-12456-9	FITTING VA SWVE 8-L G1/4	L	8	G 1/4	28	9	19	17	Stainless steel	160	2 320	82	0.18					
223-12456-1	FITTING VA SWVE 10-L G1/4	L	10	G 1/4	29	9	19	22	Stainless steel	160	2 320	87	0.19					
223-14089-5	FITTING VA SWVE 12-L G3/8	L	12	G 3/8	30	9	19	22	Stainless steel	100	1 450	130	0.29					
223-14089-6	FITTING VA SWVE 16-S G1/2	S	16	G 1/2	40	11	27	30	Stainless steel	100	1 450	321	0.71					

Banjo fittings WH (high-pressure)

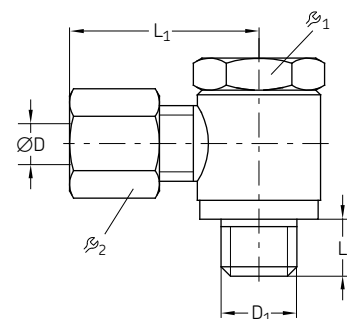

Order number	Designation	Series	Tube		L ₁	L ₂	R ₁	R ₂	Material	Operating pressure max. Weight								
			ØD	D ₁						bar	psi	g	lb					
											mm	mm	mm	mm	mm	mm		
Steel, galvanized																		
223-13679-8	FITTING ST WH10-L G1/4A-KD CF	L	10	G 1/4	30	12	19	19	Steel, galvanized	315	4 570	123	0.27					
223-13679-3	FITTING ST WH10-S G3/8A-KD CF	S	10	G 3/8	35	12	24	22	Steel, galvanized	400	5 800	212	0.47					
223-13679-9	FITTING ST WH10-S M16×1.5-KD CF	S	10	M16×1.5	35	12	24	22	Steel, galvanized	315	4 570	220	0.49					
Stainless steel																		
223-14238-4	FITTING VA WH10-L G1/4	L	10	G 1/4	30	12	19	19	Stainless steel	315	4 570	123	0.27					

Double-edged cutting sleeve unions

Reducing connectors RED with cylindrical thread

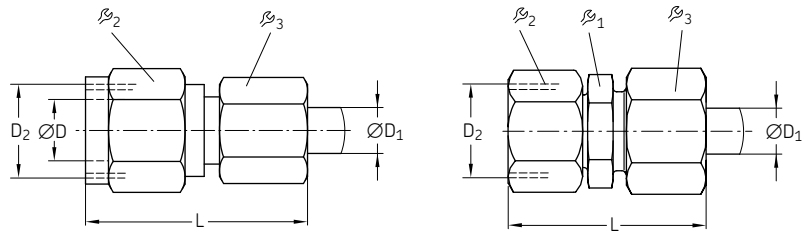

Order number	Designation	Series	Tube	Tube	D ₂	L	Ø ₁	Ø ₂	Ø ₃	Material	Operating pressure max.		Weight	
			ØD	ØD ₁							bar	psi	g	lb
96-1406-0060	FITTING ST RED 6/ 4-LL CF	LL	6	4	M10×1	29	-	12	10	Steel, galvanized	100	1 450	21	0.05
96-1408-0060	FITTING ST RED 8/ 4-LL CF	LL	8	4	M12×1	29	-	14	10	Steel, galvanized	100	1 450	28	0.06
96-1410-0060	FITTING ST RED 8/ 6-LL CF	LL	8	6	M12×1	29	-	14	12	Steel, galvanized	100	1 450	32	0.07
223-10670-3	FITTING ST RED 8/ 6-L CF	L	8	6	M14×1,5	38,0	12	17	14	Steel, galvanized	500	7 250	36	0.08
223-12582-5	FITTING ST RED10/ 6-L CF	L	10	6	M16×1,5	40,0	14	19	14	Steel, galvanized	500	7 250	48	0.11
223-14293-2	FITTING ST RED12/10-L CF	L	12	10	M18×1,5	41,0	17	22	19	Steel, galvanized	400	5 800	63	0.14
223-14152-2	FITTING ST RED15/ 8-L CF	L	15	8	M22×1,5	43,0	19	27	17	Steel, galvanized	400	5 800	102	0.22
223-14293-4	FITTING ST RED15/10-L CF	L	15	10	M22×1,5	44,0	19	27	19	Steel, galvanized	400	5 800	104	0.23
96-1541-0060	FITTING ST RED18/ 6-L CF	L	18	6	M26×1,5	43,0	24	32	14	Steel, galvanized	400	5 800	121	0.27
96-1542-0060	FITTING ST RED18/ 8-L CF	L	18	8	M26×1,5	43,0	24	32	17	Steel, galvanized	400	5 800	128	0.28
96-1543-0060	FITTING ST RED18/10-L CF	L	18	10	M26×1,5	44,0	24	32	19	Steel, galvanized	400	5 800	131	0.29
223-14293-8	FITTING ST RED18/15-L CF	L	18	15	M26×1,5	45,0	24	32	27	Steel, galvanized	400	5 800	162	0.36
96-1551-0060	FITTING ST RED22/ 6-L CF	L	22	6	M30×2	47,0	27	36	14	Steel, galvanized	250	3 625	170	0.37
223-12581-9	FITTING ST RED22/15-L CF	L	22	15	M30×2	49,0	27	36	27	Steel, galvanized	250	3 625	211	0.47
96-1556-0060	FITTING ST RED22/18-L CF	L	22	18	M30×2	50,0	27	36	32	Steel, galvanized	250	3 625	235	0.52
223-10688-1	FITTING ST RED 8/ 6-S CF	S	8	6	M16×1,5	42	14	19	17	Steel, galvanized	800	11 600	61	0.13
223-10187-1	FITTING ST RED10/ 6-S CF	S	10	6	M18×1,5	42	17	22	17	Steel, galvanized	800	11 600	74	0.16
223-13054-4	FITTING ST RED10/ 8-S CF	S	10	8	M18×1,5	42	17	22	19	Steel, galvanized	800	11 600	81	0.18
223-12287-8	FITTING ST RED12/ 8-S CF	S	12	8	M20×1,5	44	17	24	19	Steel, galvanized	630	9 140	91	0.20
223-12288-2	FITTING ST RED12/10-S CF	S	12	10	M20×1,5	46	19	24	22	Steel, galvanized	630	9 140	109	0.24
96-1633-0060	FITTING ST RED14/10-S CF	S	14	10	M22×1,5	47	19	27	22	Steel, galvanized	630	9 140	125	0.28
96-1642-0060	FITTING ST RED16/ 8-S CF	S	16	8	M24×1,5	47	22	30	19	Steel, galvanized	630	9 140	137	0.30
223-14293-1	FITTING ST RED16/10-S CF	S	16	10	M24×1,5	48	22	30	22	Steel, galvanized	630	9 140	149	0.33
96-1644-0060	FITTING ST RED16/12-S CF	S	16	12	M24×1,5	48	22	30	24	Steel, galvanized	630	9 140	156	0.34
223-12577-8	FITTING ST RED20/ 6-S CF	S	20	6	M30×2	51	27	36	17	Steel, galvanized	420	6 090	191	0.42
96-1652-0060	FITTING ST RED20/ 8-S CF	S	20	8	M30×2	51	27	36	19	Steel, galvanized	420	6 090	197	0.43
223-12577-2	FITTING ST RED20/10-S CF	S	20	10	M30×2	52	27	36	22	Steel, galvanized	420	6 090	208	0.46
223-12580-2	FITTING ST RED20/12-S CF	S	20	12	M30×2	52	27	36	24	Steel, galvanized	420	6 090	215	0.47
223-13759-7	FITTING ST RED20/16-S CF	S	20	16	M30×2	55	27	36	30	Steel, galvanized	420	6 090	254	0.56

Double-edged cutting sleeve unions

Connectors for pressure gauges MAV

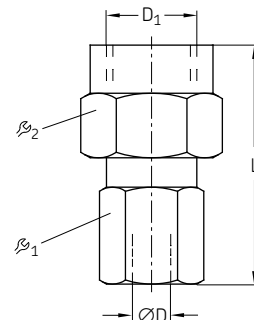

Order number	Designation	Series	Tube	D ₁	L	ϕ ₁	ϕ ₂	Material	Operating pressure max.		Weight	
			ØD						bar	psi	g	lb
Steel, galvanized												
223-12481-4	FITTING ST MAV 6-L G 1/4 CF	L	6	G 1/4	37	19	14	Steel, galvanized	315	4 570	49	0.11
223-12481-6	FITTING ST MAV 8-L G 1/4 CF	L	8	G 1/4	37	19	17	Steel, galvanized	315	4 570	55	0.12
223-13028-2	FITTING ST MAV10-L G 1/4 CF	L	10	G 1/4	38	19	19	Steel, galvanized	315	4 570	62	0.14
223-12481-8	FITTING ST MAV12-L G 1/4 CF	L	12	G 1/4	38	19	22	Steel, galvanized	315	4 570	71	0.16
441-108-132	FITTING ST MAV 8-S G 1/2 CF	S	8	G 1/2	46	27	19	Steel, galvanized	630	9 140	105	0.23
223-13028-4	FITTING ST MAV10-S G 1/2 CF	S	10	G 1/2	47	27	22	Steel, galvanized	630	9 140	111	0.24
223-12286-8	FITTING ST MAV12-S G 1/2 CF	S	12	G 1/2	47	27	24	Steel, galvanized	630	9 140	131	0.29
Stainless steel												
223-13685-3	FITTING VA MAV 6-L G 1/4 CF	L	6	G 1/4	37	19	14	Stainless steel	315	4 570	49	0.11
223-13685-1	FITTING VA MAV10-S G 1/2 CF	S	10	G 1/2	47	27	22	Stainless steel	630	9 140	111	0.24

Connectors for pressure gauges MAVE

(Swivel with O-ring)

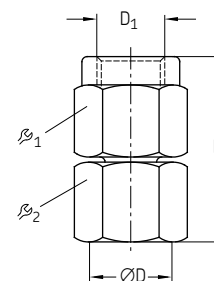

Order number	Designation	Series	Tube	D ₁	L	ϕ ₁	ϕ ₂	Material	Operating pressure max.		Weight	
			ØD						bar	psi	g	lb
Steel, galvanized												
96-8804-0058	FITTING ST MAVE 4-L G 1/4 CF	L	4	G 1/4	33	19	10	Steel, galvanized	315	4 570	42	0.09
223-13655-1	FITTING ST MAVE 6-L G 1/4 CF	L	6	G 1/4	35,5	19	14	Steel, galvanized	315	4 570	46	0.10
223-10889-2	FITTING ST MAVE 8-L G 1/4 CF	L	8	G 1/4	35,5	19	17	Steel, galvanized	315	4 570	52	0.11
223-13655-7	FITTING ST MAVE 10-L G 1/4 CF	L	10	G 1/4	36,0	19	19	Steel, galvanized	315	4 570	59	0.13
223-14268-4	FITTING ST MAVE 12-L G 1/4 CF	L	12	G 1/4	36,0	19	22	Steel, galvanized	315	4 570	70	0.15
96-8906-0058	FITTING ST MAVE 6-S G 1/2 CF	S	6	G 1/2	42,5	27	17	Steel, galvanized	630	9 140	95	0.21
223-13655-2	FITTING ST MAVE 10-S G 1/2 CF	S	10	G 1/2	43,5	27	22	Steel, galvanized	630	9 140	109	0.24
223-13655-4	FITTING ST MAVE 12-S G 1/2 CF	S	12	G 1/2	45,0	27	24	Steel, galvanized	630	9 140	125	0.28
Stainless steel												
223-14268-7	FITTING AV MAVE 6-L G 1/4 CF	L	6	G 1/4	35,5	19	14	Stainless steel	315	4 570	46	0.10
223-13655-5	FITTING AV MAVE 10-S G 1/2 CF	S	10	G 1/2	43,5	27	22	Stainless steel	630	9 140	109	0.24

Double-edged cutting sleeve unions

L-connectors EL, EVL directionally adjustable

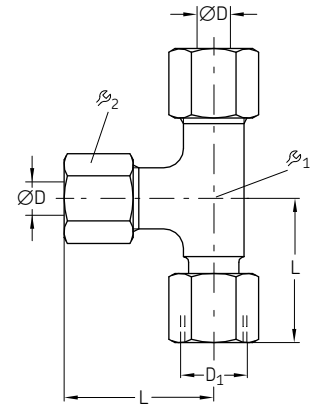

Order number	Designation	Series	Tube	L	β_1	β_2	Material	Operating pressure max. Weight				
			ØD					ØD ₁	mm	mm	mm	bar
Steel, galvanized												
223-14190-6	STUD ST EL 6-L CF	L	6	M12×1,5	27	12	14	Steel, galvanized	500	7 250	68	0.15
223-14190-7	STUD ST EL 8-L CF	L	8	M14×1,5	29	12	17	Steel, galvanized	500	7 250	87	0.19
223-13040-9	STUD ST EL 10-L CF	L	10	M16×1,5	30	14	19	Steel, galvanized	500	7 250	110	0.24
223-13761-5	STUD ST EL 12-L CF	L	12	M18×1,5	32	17	22	Steel, galvanized	400	5 800	151	0.33
223-14190-5	STUD ST EL 15-L CF	L	15	M22×1,5	36	19	27	Steel, galvanized	400	5 800	245	0.54
443-418-181	STUD ST EL 18-L CF	L	18	M26×1,5	40	24	32	Steel, galvanized	400	5 800	369	0.81
223-13040-3	STUD ST EL 6-S CF	S	6	M14×1,5	31	12	17	Steel, galvanized	800	11 600	103	0.23
223-13040-7	STUD ST EL 8-S CF	S	8	M16×1,5	32	14	19	Steel, galvanized	800	11 600	130	0.29
223-14190-2	STUD ST EL 10-S CF	S	10	M18×1,5	34	17	22	Steel, galvanized	800	11 600	136	0.30
223-14190-4	STUD ST EL 12-S CF	S	12	M20×1,5	38	17	24	Steel, galvanized	630	9 140	212	0.47
223-14190-1	STUD ST EL 16-S CF	S	16	M24×1,5	43	24	30	Steel, galvanized	630	9 140	404	0.89
223-13761-7	STUD ST EL 20-S CF	S	20	M30×2	48	27	36	Steel, galvanized	420	6 090	601	1.33
443-410-211	FITTING ST EVL 10-S G3/8A CF	S	10	G 3/8	34	17	22	Steel, galvanized	630	9 140	226	0.50
443-410-161	FITTING ST EVL 10-L G1/4A CF	L	10	G 1/4	30	14	19	Steel, galvanized	250	3 625	132	0.29
Stainless steel												
223-14244-8	STUD VA EL 10-L	L	10	M16×1,5	30	14	19	Stainless steel	315	4 570	110	0.24
223-14244-6	STUD VA EL 20-S	S	20	M30×2	48	27	36	Stainless steel	400	5 800	601	1.33

Double-edged cutting sleeve unions

Tee screw-in connectors TE, TH with metrical thread

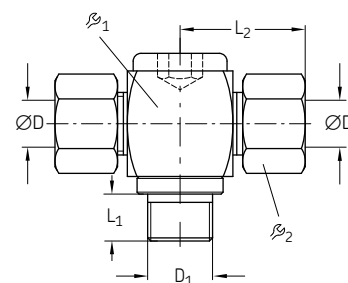

Order number	Designation	Tube		L ₁	L ₂	Ø ₁	Ø ₂	Material	Operating pressure max.		Weight	
		Series	ØD D ₁						bar	psi	g	lb
		mm	mm	mm	mm	mm	mm					
96-6404-0058	FITTING ST TE 4-LL M 8X1,0 K CF	LL	4 M8×1 tap.	8	21	9	10	Steel, galvanized	100	1 450	19	0.04
96-6406-0058	FITTING ST TE 6-LL M 10X1,0 K CF	LL	6 M10×1 tap.	8	21	11	12	Steel, galvanized	100	1 450	40	0.09
96-6408-0058	FITTING ST TE 8-LL M 10X1,0 K CF	LL	8 M10×1 tap.	8	23	12	14	Steel, galvanized	100	1 450	30	0.07
96-0906-0058	FITTING ST TE 6-L M 10X1,0 K CF	L	6 M10×1 tap.	8	27	12	14	Steel, galvanized	250	3 625	50	0.11
445-910-551	FITTING ST TE 10-L M 14X1,5 K CF	L	10 M14×1,5 tap.	12	30	14	19	Steel, galvanized	250	3 625	100	0.22
96-1806-0058	FITTING ST TE 6-S M 12X1,5 K CF	S	6 M12×1,5 tap.	12	31	14	17	Steel, galvanized	400	5 800	67	0.15
96-1808-0058	FITTING ST TE 8-S M 14X1,5 K CF	S	8 M14×1,5 tap.	12	32	14	19	Steel, galvanized	400	5 800	100	0.22
445-735-101	FITTING ST TH 10-L M 14X1,5 K CF	L	10 M14×1,5	12	30	19	19	Steel, galvanized	315	3 625	154	0.34
445-739-151	FITTING ST TH 15-L M 18X1,5 K CF	L	15 M18×1,5	14	37	30	32	Steel, galvanized	250	3 625	352	0.78

Tee screw-in connectors TE, TH with Whitworth pipe thread

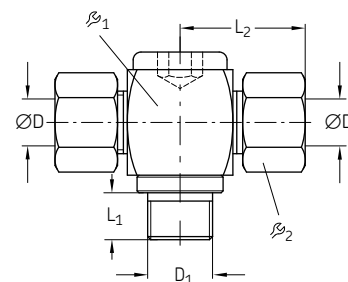

Order number	Designation	Tube		L ₁	L ₂	Ø ₁	Ø ₂	Material	Operating pressure max.		Weight	
		Series	ØD D ₁						bar	psi	g	lb
		mm	mm	mm	mm	mm	mm					
96-6304-0058	FITTING ST TE 4-LL R 1/8K CF	LL	4 R 1/8	8	21	10	11	Steel, galvanized	100	1 450	14	0.03
96-6306-0058	FITTING ST TE 6-LL R 1/8K CF	LL	6 R 1/8	8	21	11	12	Steel, galvanized	100	1 450	26	0.06
96-6308-0058	FITTING ST TE 8-LL R 1/8K CF	LL	8 R 1/8	8	23	12	14	Steel, galvanized	100	1 450	32	0.07
96-0806-0058	FITTING ST TE 6-L R 1/8K CF	L	6 R 1/8	8	27	12	14	Steel, galvanized	250	3 625	38	0.08
96-0808-0058	FITTING ST TE 8-L R 1/4K CF	L	8 R 1/4	12	29	14	17	Steel, galvanized	250	3 625	75	0.17
96-0810-0058	FITTING ST TE 10-L R 1/4K CF	L	10 R 1/4	12	30	14	19	Steel, galvanized	250	3 625	100	0.22
96-0818-0058	FITTING ST TE 18-L R 1/2K CF	L	18 R 1/2	14	40	24	32	Steel, galvanized	250	3 625	149	0.33
96-1706-0058	FITTING ST TE 6-S R 1/4K CF	S	6 R 1/4	12	31	12	17	Steel, galvanized	400	5 800	100	0.22
445-721-121	FITTING ST TH 12-L G 3/8 CF	L	12 R 3/8	12	33	24	22	Steel, galvanized	315	4 570	249	0.55
445-713-151	FITTING ST TH 15-L G 1/2 CF	L	15 R 1/2	14	37	30	27	Steel, galvanized	315	4 570	415	0.92
445-717-221	FITTING ST TH 22-L G 3/4 CF	L	22 R 3/4	16	44	36	36	Steel, galvanized	160	2 320	763	1.68

Double-edged cutting sleeve unions

Swivel nut branch tee ET

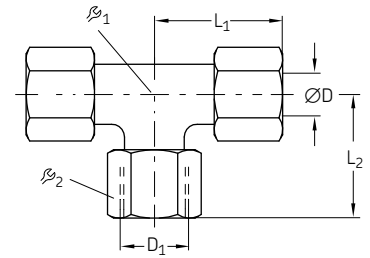

Order number	Designation	Series	Tube		L ₁	L ₂	β ₁	β ₂	Material	Operating pressure max.		Weight	
			ØD	D ₁						bar	psi	g	lb
		mm mm		mm mm		mm mm							
223-14189-6	STUD ST ET 6-L CF	L	6	M12×1,5	27	26	12	14	Steel, galvanized	500	7 250	68	0.15
223-13040-1	STUD ST ET 8-L CF	L	8	M14×1,5	29	26,5	12	17	Steel, galvanized	500	7 250	87	0.19
223-14189-1	STUD ST ET10-L CF	L	10	M16×1,5	30	29	14	19	Steel, galvanized	500	7 250	113	0.25
223-13785-8	STUD ST ET12-L CF	L	12	M18×1,5	32	29,5	17	22	Steel, galvanized	400	5 800	153	0.34
223-14189-7	STUD ST ET15-L CF	L	15	M22×1,5	36	32,5	19	27	Steel, galvanized	400	5 800	253	0.56
96-3118-0060	STUD ST ET18-L CF	L	18	M26×1,5	40	35,5	24	32	Steel, galvanized	400	5 800	375	0.83
96-3122-0060	STUD ST ET22-L CF	L	22	M30×1,5	44	38,5	27	36	Steel, galvanized	250	3 625	486	1.07
445-806-351	STUD ST ET 6-S CF	S	6	M14×1,5	31	27	12	17	Steel, galvanized	800	11 600	101	0.22
223-10374-3	STUD ST ET 8-S CF	S	8	M16×1,5	32	27,5	14	19	Steel, galvanized	800	11 600	135	0.30
223-14189-5	STUD ST ET10-S CF	S	10	M18×1,5	34	30	17	22	Steel, galvanized	800	11 600	181	0.40
223-14189-9	STUD ST ET12-S CF	S	12	M20×1,5	38	31	17	24	Steel, galvanized	630	9 140	212	0.47
223-14189-2	STUD ST ET16-S CF	S	16	M24×1,5	43	36,5	24	30	Steel, galvanized	630	9 140	383	0.84
223-14189-3	STUD ST ET20-S CF	S	20	M30×1,5	48	44,5	27	36	Steel, galvanized	420	6 090	614	1.35

Swivel nut elbow EW

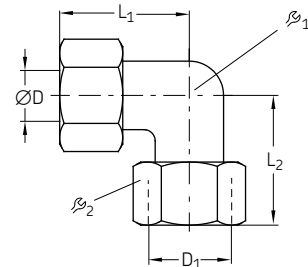

Order number	Designation	Series	Tube		L ₁	L ₂	β ₁	β ₂	Material	Operating pressure max.		Weight	
			ØD	D ₁						bar	psi	g	lb
		mm mm		mm mm		mm mm							
223-14171-1	STUD ST EW 6-L CF	L	6	M12×1,5	27	26	12	14	Steel, galvanized	500	7 250	46	0.10
223-14102-3	STUD ST EW 8-L CF	L	8	M14×1,5	29	27,5	12	17	Steel, galvanized	500	7 250	59	0.13
443-306-343	STUD ST EW 6-S CF	S	6	M14×1,5	31	27	12	17	Steel, galvanized	800	11 600	67	0.15
223-14171-8	STUD ST EW10-S CF	S	10	M18×1,5	34	30	17	22	Steel, galvanized	800	11 600	126	0.28
223-14171-4	STUD ST EW16-S CF	S	16	M24×1,5	43	36,5	24	30	Steel, galvanized	630	9 140	284	0.63
223-14171-5	STUD ST EW20-S CF	S	20	M30×1,5	48	44,5	27	36	Steel, galvanized	420	6 090	422	0.93

Double-edged cutting sleeve unions

Swivels DVWE

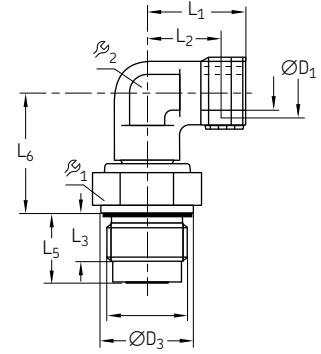

Order number	Designation	Tube Ø		Series	Speed max.	Operation pressure		Material	Weight	
		mm	in			min ⁻¹	bar		psi	g
Steel galvanized										
223-13694-6	Fitting DVWE10-L G 3/8A CF	10	G 3/8	L	21	40	580	Steel galvanized	83	0.18
223-13694-1	Fitting DVWE10-S G 3/8A CF	10	G 3/8	S	9	100	1 450	Steel galvanized	103	0.23
Stainless steel										
223-13694-7	Fitting DVWE10-L G 3/8A	10	G 3/8	L	21	40	580	Stainless steel	83	0.18
223-13694-3	Fitting DVWE10-S G 3/8A	10	G 3/8	S	9	100	1 450	Stainless steel	103	0.23

Swivels DG

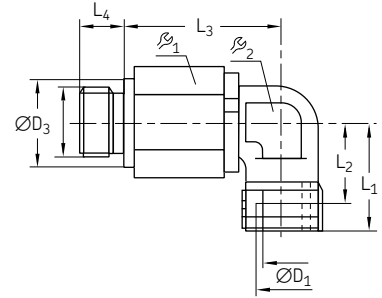

Order number	Designation	Tube Ø		Series	Speed max.	Operation pressure		Material	Weight	
		mm	in			min ⁻¹	bar		psi	g
223-13655-7	Fitting DG104/ 6-S G 1/4A CF	6	G 1/4	S	400	100	1 450	Steel galvanized	131	0.29
223-13655-8	Fitting DG104/ 8-S G 1/4A CF	8	G 1/4	S	400	100	1 450	Steel galvanized	135	0.30
223-13655-9	Fitting DG104/12-S G 3/8A CF	12	G 3/8	S	200	100	1 450	Steel galvanized	284	0.62

Double-edged cutting sleeve unions

Blanking plug for cones BUZ

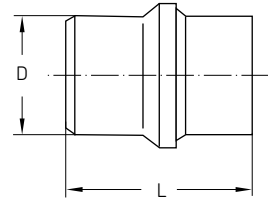

Order number	Designation	Series	D		Material	Operating pressure max.		Weight	
			mm	mm		bar	psi	g	lb
Steel galvanized									
223-13640-1	PLUG ST BUZ 6-L/S CF	L/S	6	19,5	Steel, galvanized	315	4 570	5	0.01
223-13640-5	PLUG ST BUZ 8-L/S CF	L/S	8	19,5	Steel, galvanized	315	4 570	8	0.02
223-13640-3	PLUG ST BUZ10 -L/S CF	L/S	10	21,0	Steel, galvanized	315	4 570	13	0.03
223-13640-4	PLUG ST BUZ12 -L/S CF	L/S	12	21,8	Steel, galvanized	315	4 570	20	0.04
223-13640-9	PLUG ST BUZ18 -L CF	L/S	18	24,0	Steel, galvanized	315	4 570	45	0.10
223-13640-8	PLUG ST BUZ16 -S CF	S	16	25,5	Steel, galvanized	400	5 800	39	0.09
223-13640-2	PLUG ST BUZ20 -S CF	S	20	30,5	Steel, galvanized	400	5 800	73	0.16
Stainless steel									
223-14215-5	PLUG VA BUZ 6-L/S	L/S	6	19,5	Stainless steel	315	4 570	5	0.01
223-14215-3	PLUG VA BUZ10 -L/S	L/S	10	21,0	Stainless steel	315	4 570	13	0.03
223-14215-2	PLUG VA BUZ12 -L/S	L/S	12	21,8	Stainless steel	315	4 570	20	0.04
223-10638-3	PLUG VA BUZ16 -S	S	16	25,5	Stainless steel	400	5 800	39	0.09
223-14215-4	PLUG VA BUZ20 -S	S	20	30,5	Stainless steel	400	5 800	73	0.16

Soft-seal cutting sleeve union (SSCS)

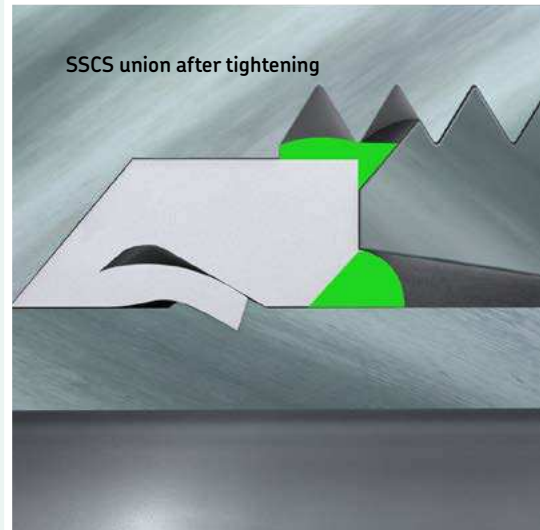
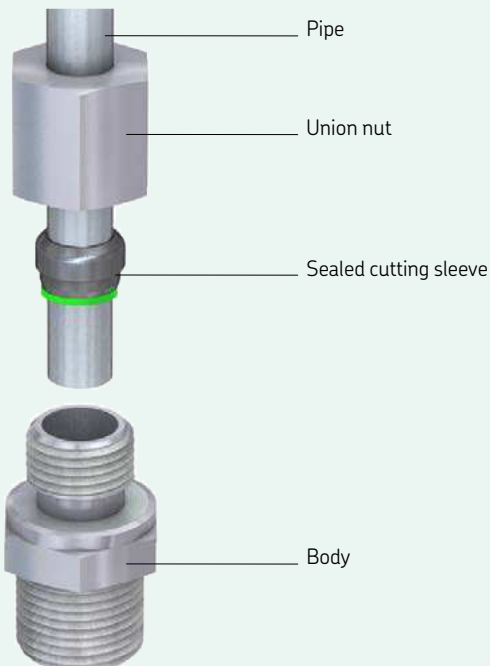

Description

Soft-seal cutting sleeve unions (SSCS) consist of a union nut, a cutting sleeve, a support ring with soft seal, and a body with another soft seal. To mount the union, the union nut and the sealed cutting sleeve have to be put on the pipe end. All parts must be aligned as shown on the illustration above. Then the pipe end can be pushed into the body before tightening the union nut. During that process, the sealed cutting sleeve cuts into the pipe to seal the connection as shown in the illustration above. In addition, the union also is sealed by the soft seal.

Features and benefits

- Compact installation dimensions
- Virtually leakage-free, high-pressure union
- Recommended for high-pressure oil and grease applications
- Common fitting system for high-pressure systems
- Higher nominal pressures than DECS unions (series "L" can often be used instead of "S")
- High sealing capacity, especially with low-viscosity media (e.g. no sweating with low-viscosity oils)
- Easy assembly by tightening the union nut to the stop (no risk of under- or over-assembly)
- Pipe vibration dampening resulting from pipe fixation during assembly (caused by SSCS union)
- Wide operating temperature range from -25 to 80 °C
- Tightening forces 25% lower than TECS unions

Soft-seal cutting sleeve union

Straight screw-in connectors GEZ

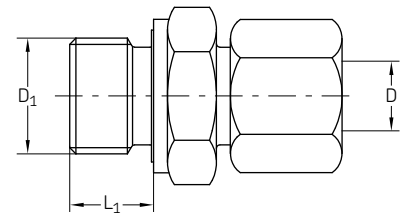

Order number	Designation	Series	Tube	L	L ₁	R ₁	R ₂	Material	Operating pressure max.		Weight		
			ØD						ØD ₁	bar	psi	g	lb
		mm		mm	mm	mm	mm						
471-004-191	FITTING ST GE 4Z-LL G 1/8A ED CF	LL	4	G 1/8	19	6,5	14	10	Steel galvanized	100	1450	15	0.03
471-004-311	FITTING ST GE 4Z-LL M 10X1,0 ED CF	LL	4	M10x1	26	8	10	10	Steel galvanized	100	1450	15	0.03
471-006-192	FITTING ST GE 6Z-L G 1/8A ED CF	L	6	G 1/8	23	8	14	14	Steel galvanized	500	7250	25	0.06
471-006-161	FITTING ST GE 6Z-L G 1/4A ED CF	L	6	G 1/4	25	12	19	14	Steel galvanized	500	7250	40	0.09
471-006-311	FITTING ST GE 6Z-L M 10X1,0 ED CF	L	6	M10x1	23	8	14	14	Steel galvanized	500	7250	25	0.06
471-006-351	FITTING ST GE 6Z-L M 14X1,5 ED CF	L	6	M14x1,5	27	12	14	14	Steel galvanized	400	5800	44	0.10
471-008-130	FITTING ST GE 8Z-L G 1/8A ED CF	L	8	G 1/8	24	8	14	17	Steel galvanized	500	7250	33	0.07
471-008-161	FITTING ST GE 8Z-L G 1/4A ED CF	L	8	G 1/4	25	12	19	17	Steel galvanized	500	7250	44	0.10
471-008-131	FITTING ST GE 8Z-L G 1/2A ED CF	L	8	G 1/2	27	14	27	17	Steel galvanized	400	5800	90	0.20
471-008-211	FITTING ST GE 8Z-L G 3/8A ED CF	L	8	G 3/8	26	12	22	17	Steel galvanized	400	5800	60	0.13
471-008-314	FITTING ST GE 8Z-L M 10X1,0 ED CF	L	8	M10x1	34	7	17	14	Steel galvanized	45	650	40	0.09
471-008-345	FITTING ST GE 8Z-L M 12X1,5 ED CF	L	8	M12x1,5	25	12	17	17	Steel galvanized	500	7250	37	0.08
471-008-351	FITTING ST GE 8Z-S M 14X1,5 ED CF	S	8	M14x1,5	30	12	19	19	Steel galvanized	400	5800	50	0.11
471-008-391	FITTING ST GE 8Z-L M 18X1,5 ED CF	L	8	M18x1,5	38	11	24	17	Steel galvanized	400	5800	70	0.15
471-010-161	FITTING ST GE 10Z-L G 1/4A ED CF	L	10	G 1/4	26	12	19	19	Steel galvanized	500	7250	50	0.11
471-010-211	FITTING ST GE 10Z-L G 3/8A ED CF	L	10	G 3/8	27	12	22	22	Steel galvanized	400	5800	60	0.13
471-010-312	FITTING ST GE 10Z-L M 10X1,0 ED CF	L	10	M10x1	32	8	19	17	Steel galvanized	500	7250	43	0.09
471-010-351	FITTING ST GE 10Z-L M 14X1,5 ED CF	L	10	M14x1,5	26	12	19	19	Steel galvanized	500	7250	50	0.11
471-010-391	FITTING ST GE 10Z-L M 18X1,5 ED CF	L	10	M18x1,5	27	12	24	19	Steel galvanized	400	5800	75	0.17
471-012-161	FITTING ST GE 12Z-L G 1/4A ED CF	L	12	G 1/4	27	12	19	22	Steel galvanized	400	5800	58	0.13
471-012-211	FITTING ST GE 12Z-L G 3/8A ED CF	L	12	G 3/8	27	12	22	22	Steel galvanized	400	5800	73	0.16
471-012-391	FITTING ST GE 12Z-L M 18X1,5 ED CF	L	12	M18x1,5	27	12	24	22	Steel galvanized	400	5800	120	0.26

Soft-seal cutting sleeve union

Straight screw-in connectors with shortened thread and function nut GEZ (short)

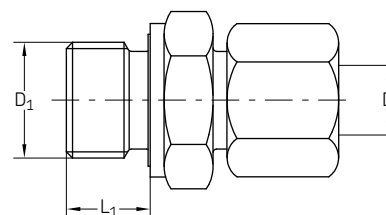

Order number	Designation	Tube Series	ØD	ØD ₁	L ₁	r ₁	r ₂	Material	Operating pressure max.		Weight	
									bar	psi	g	lb
			mm	mm	mm	mm	mm					
471-006-320	TB.FITT ST GE 6Z-LL M 10x1,0 ED CF (SHORT)	LL	6	M10x1	31	14	14	Steel galvanized	100	1 450	27	0.06
471-006-319	TB.FITT ST GE 6Z-LL M 12x1,0 ED CF (SHORT)	LL	6	M12x1	31	14	19	Steel galvanized	100	1 450	40	0.09
471-008-312	TB.FITT ST GE 8Z-LL M 10x1,0 ED CF (SHORT)	LL	8	M10x1	34	17	14	Steel galvanized	100	1 450	35	0.08
471-008-318	TB.FITT ST GE 8Z-LL M 12x1,0 ED CF (SHORT)	LL	8	M12x1	32	17	19	Steel galvanized	100	1 450	70	0.15
471-010-312	TB.FITT ST GE 10Z-LL M 10x1,0 ED CF (SHORT)	LL	10	M10x1	32	19	17	Steel galvanized	100	1 450	43	0.09
471-010-318	TB.FITT ST GE 10Z-LL M 12x1,0 ED CF (SHORT)	LL	10	M12x1	34	19	19	Steel galvanized	100	1 450	45	0.10
471-012-312	TB.FITT ST GE 12Z-LL M 10x1,0 ED CF (SHORT)	LL	12	M10x1	36	22	22	Steel galvanized	100	1 450	57	0.13
417-012-313	TB.FITT ST GE 12Z-LL M 12x1,0 ED CF (SHORT)	LL	12	M12x1	34	22	22	Steel galvanized	100	1 450	51	0.11

Straight bulkhead connectors with function nut SVZ

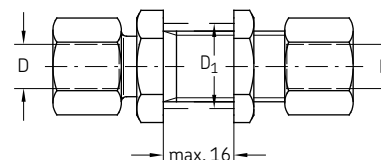

Order number	Designation	Tube Series	ØD	D ₁	L ₁	L ₂	r ₁	r ₂	r ₃	Material	Operating pressure max.		Weight	
											bar	psi	g	lb
			mm	mm	mm	mm	mm	mm	mm					
474-606-331	FITTING ST SV 6Z-L CF	L	6	12,5	22	42	17	17	14	Steel galvanized	500	7 250	61	0.13
474-608-351	FITTING ST SV 8Z-L CF	L	8	14,5	23	42	19	19	17	Steel galvanized	500	7 250	83	0.18
474-610-351	FITTING ST SV10Z-L CF	L	10	16,5	25	43	22	22	19	Steel galvanized	500	7 250	100	0.22
474-612-391	FITTING ST SV12Z-L CF	L	12	18,5	25	44	24	24	22	Steel galvanized	400	5 800	134	0.30
474-615-431	FITTING ST SV15Z-L CF	L	15	22,5	27	46	27	30	27	Steel galvanized	400	5 800	224	0.49
474-618-441	FITTING ST SV18Z-L CF	L	18	26,5	30	49	32	36	32	Steel galvanized	400	5 800	344	0.76

Soft-seal cutting sleeve union

Straight connectors (tube to tube) with function nut GZ

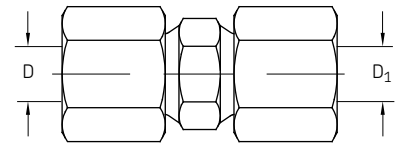

Order number	Designation	Series	Tube	L	\varnothing	Material	Operating pressure max.		Weight	
			\varnothing D				mm	mm	mm	bar
474-506-061	FITTING ST G 6Z-L CF	L	6	39	14	Steel galvanized	500	7 250	35	0.08
474-508-081	FITTING ST G 8Z-L CF	L	8	40	17	Steel galvanized	500	7 250	50	0.11
474-510-101	FITTING ST G10Z-L CF	L	10	42	19	Steel galvanized	500	7 250	64	0.14
474-512-121	FITTING ST G12Z-L CF	L	12	43	22	Steel galvanized	400	5 800	87	0.19
474-515-151	FITTING ST G15Z-L CF	L	15	46	27	Steel galvanized	400	5 800	144	0.32
474-518-181	FITTING ST G18Z-L CF	L	18	48	32	Steel galvanized	400	5 800	200	0.44

Tee connectors with function nut TZ

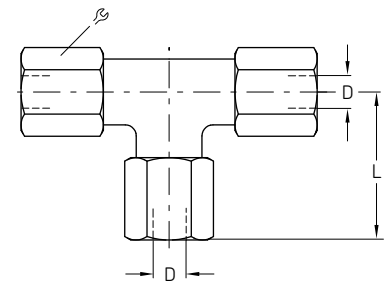

Order number	Designation	Series	Tube	L	\varnothing	Material	Operating pressure max.		Weight	
			\varnothing D				mm	mm	mm	bar
476-006-001	FITTING ST T 6Z-L CF	L	6	27	14	Steel galvanized	500	7 250	70	0.15
476-008-001	FITTING ST T 8Z-L CF	L	8	29	17	Steel galvanized	500	7 250	90	0.20
476-010-001	FITTING ST T10Z-L CF	L	10	30	19	Steel galvanized	500	7 250	114	0.25
476-012-001	FITTING ST T12Z-L CF	L	12	32	22	Steel galvanized	400	5 800	153	0.34
476-015-001	FITTING ST T15Z-L CF	L	15	36	27	Steel galvanized	400	5 800	241	0.53

Soft-seal cutting sleeve union

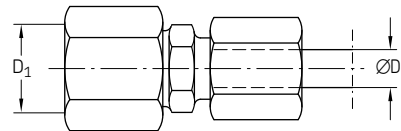
Reducing connectors
with function nut REDZ

Order number	Designation	Series	Tube			L	R_{s1}	R_{s2}	R_{s3}	Material	Operating pressure max.		Weight	
			ØD	D ₁	D ₂						bar	psi	g	lb
			mm	mm	mm	mm	mm	mm	mm					
473-810-371	Fitting REDZ ST10/ 6Z-S CF	S	10	6	M18x1,5	42	17	22	17	Steel galvanized	800	11 600	48	0.11
473-806-351	Fitting REDZ ST 8/ 6Z-L CF	L	8	6	M14x1,5	38	12	17	14	Steel galvanized	500	7 250	40	0.09
473-808-371	Fitting REDZ ST10/ 8Z-L CF	L	10	8	M16x1,5	40	17	22	17	Steel galvanized	500	7 250	58	0.13
473-806-391	Fitting REDZ ST12/ 6Z-L CF	L	12	6	M20x1,5	40	17	22	14	Steel galvanized	400	5 800	60	0.13
473-808-392	Fitting REDZ ST12/ 8Z-L CF	L	12	8	M18x1,5	40	17	22	17	Steel galvanized	400	5 800	69	0.15
473-810-391	Fitting REDZ ST12/10Z-L CF	L	12	10	M18x1,5	41	17	22	19	Steel galvanized	400	5 800	72	0.16

Soft-seal cutting sleeve union

Cone plugs VKA

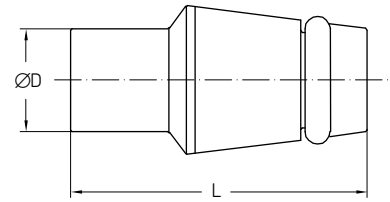

Order number	Designation	Series	Tube		Material	Operating pressure max.		Weight		
			ØD mm	L mm		bar	psi	g	lb	
Steel galvanized										
223-10297-5	BLANKING PLUG ST VKA 6-L/S CF	L/S	6	18,5	Steel galvanized	800	11 600	6	0.01	
460-708-001	BLANKING PLUG ST VKA 8-L CF	L	8	18,5	Steel galvanized	500	7 250	9	0.02	
223-10297-6	BLANKING PLUG ST VKA10-L/S CF	L/S	10	15	Steel galvanized	800	11 600	15	0.03	
223-10297-9	BLANKING PLUG ST VKA12-L/S CF	L/S	12	21	Steel galvanized	630	9 140	21	0.05	
223-10297-7	BLANKING PLUG ST VKA20-S CF	S	20	28,5	Steel galvanized	420	6 090	78	0.17	
223-14241-2	BLANKING PLUG ST VKA30-S CF	S	30	30,5	Steel galvanized	420	6 090	180	0.40	
Stainless steel										
223-14241-9	BLANKING PLUG VA VKA10-L/S	L/S	10	15	Stainless steel	630	9 140	15	0.03	
223-10297-1	BLANKING PLUG VA VKA20-S	S	20	28,5	Stainless steel	400	5 800	78	0.17	
223-14241-5	BLANKING PLUG VA VKA30-S	S	30	30,5	Stainless steel	400	5 800	180	0.40	

Adapter fittings

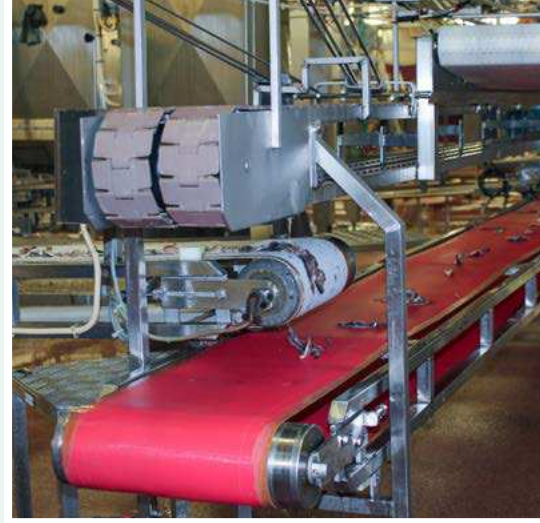

Description

Adapter fittings are used where no standard fittings are available or may need too much space. In fact adapter fittings are not the best solution because with it comes the risk of an additional leakage point in the system. Therefore the sealing, the material and the design and the operation pressure of an adapter fitting plays an important role in the selection process. SKF offers adapters for different applications with suitable operating pressures, fittings, seals and designs.

Adapter fittings are available in different designs to serve different application requirements on system pressure:

- 45 bar designs
- 350 bar designs
- LL (very light, max. 100 bar)
- L (light, max. 500 bar)
- S (heavy, max. 800 bar)

Features and Benefits

- Fast and virtually leakage-free connection
- Designs for almost every applications
- Space-saving small design



Applications

- Food and beverage industry
- Renewable energy industry
- Construction machinery
- Material handling
- On-road vehicles
- Machine tools
- Etc.

Adapter fittings

Reducing connectors with cylindrical thread
for operating pressures up to 45 bar
(sealed by flat washer acc. to DIN 7603)

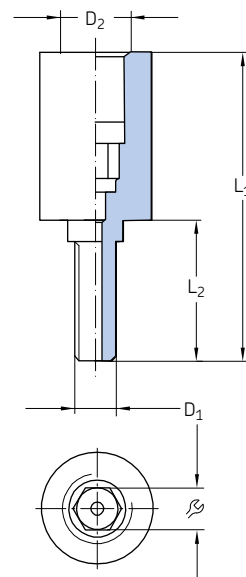

Order number	Designation	D ₁	D ₂	L ₁	L ₂	⌀	Material	Weight	
								mm	mm
843-130-021	ADAPTER ST M 3AX M 5I CF	M3	M5	22	10	3 ¹⁾	Steel, galvanized surface	4	0.01
843-130-022	ADAPTER ST M 4AX M 5I CF	M4	M5	22	10	3 ¹⁾	Steel, galvanized surface	5	0.01
843-130-023	ADAPTER ST M 5AX M 5I CF	M5	M5	22	10	3 ¹⁾	Steel, galvanized surface	11	0.02

¹⁾ Female thread

Reducing connectors with tapered thread
for operating pressures up to 45 bar

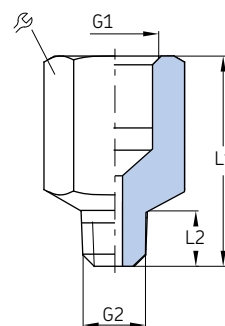

Order number	Designation	G ₁	G ₂	L ₁	L ₂	⌀	Material	Weight	
								mm	mm
406-044-S1	ADAPTER ST M10X1KAX R1/4I CF	M10×1 tap.	R 1/4	22,5	8	17	Steel, galvanized surface	20	0.04

Adapter fittings

Reducing connectors with cylindrical thread for operating pressures up to 45 bar (sealed by flat washer acc. to DIN 7603)

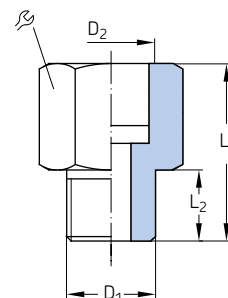

Order number	Designation	D ₁	D ₂	L ₁	L ₂	⌀	Material	Weight	
								g	lb
Steel, galvanized surface									
401-013-161	ADAPTER ST G1/4A X G1/2I CF	G 1/4 A	G 1/2	40	12	27	Steel, galvanized surface	114	0.25
401-011-132	ADAPTER ST G1/2A X G1I CF	G 1/2 A	G 1	49	14	41	Steel, galvanized surface	222	0.49
433-890-131	ADAPTER ST G1/2A X G1 1/4I CF	G 1/2 A	G 1 1/4	53	14	55	Steel, galvanized surface	210	0.46
401-013-171	ADAPTER ST G3/4A X G1/2I CF	G 3/4 A	G 1/2	41	16	32	Steel, galvanized surface	140	0.31
406-024	ADAPTER MS M10X1A X G1/8I CF	M10×1	G 1/8	20	8	14	Steel, galvanized surface	15	0.03
P-78.01	ADAPTER ST M12X1A X G1/4I CF	M12×1	G 1/4	27	8,5	19	Steel, galvanized surface	31	0.07
401-016-371	ADAPTER ST M16X1,5A X G1/4I CF	M16×1.5	G 1/4	30	12	19	Steel, galvanized surface	39	0.09
243-001.10	ADAPTER ST M16X1,5A X G1/2I CF	M16×1.5	G 1/2	31	9	27	Steel, galvanized surface	60	0.13
267-001.36	ADAPTER ST M18X1,5A X G3/8I CF	M18×1.5	G 3/8	32	10	22	Steel, galvanized surface	50	0.11
243-001.20	ADAPTER ST M18X1,5A X G1/2I CF	M18×1.5	G 1/2	32	10	27	Steel, galvanized surface	59	0.13
44-1755-2029	ADAPTER ST M20X1,5A X G1/4I CF	M20×1.5	G 1/4	28	12	24	Steel, galvanized surface	59	0.13
Brass									
267-001.47	ADAPTER MS G3/8A X G3/4I	G 3/8 A	G 1/4	31	10	22	Brass	60	0.13
267-001.60	ADAPTER MS G3/8A X G1/2I	G 3/8 A	G 1/2	34	10	27	Brass	78	0.17
401-019-132	ADAPTER MS G1/2A X G1/8I	G 1/2 A	G 1/8	24	12	27	Brass	22	0.05
DZ333	ADAPTER MS G1/2A X G1/4I	G 1/2 A	G 1/4	24	12	27	Brass	64	0.14
401-013-131	ADAPTER MS G1/2A X G1/2I	G 1/2 A	G 1/2	40,5	12	27	Brass	107	0.24
DZ334	ADAPTER MS G1/2A X G3/8I	G 1/2 A	G 3/8	31	12	27	Brass	83	0.18
267-001.03	ADAPTER MS G1/2A X G3/4I	G 1/2 A	G 3/4	40	12	36	Brass	166	0.37
401-016-312	ADAPTER MS M10X1A X G1/4I	M10×1	G 1/4	26,5	7,5	17	Brass	25	0.06
401-019-352	ADAPTER MS M14X1,5X1A X G1/8I	M14×1,5	G 1/8	20	9	17	Brass	24	0.05

Adapter for pressure gauges for operating pressures up to 45 bar (sealed by flat washer acc. to DIN 7603)

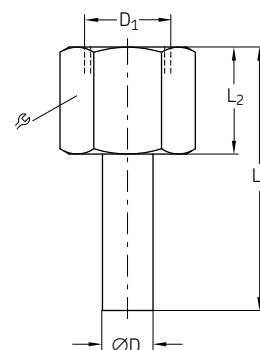

Order number	Designation	Series	Tube ØD	D ₁	L ₁	L ₂	⌀	Material	Operating pressure max. Weight			
									bar	psi	g	lb
248-610.01	ADAPTER	L	6	G 1/4	46	22	17	Brass	45	650	30	0.07

Adapter fittings

Adapter for pressure gauges with cylindrical thread for operating pressures up to 45 bar

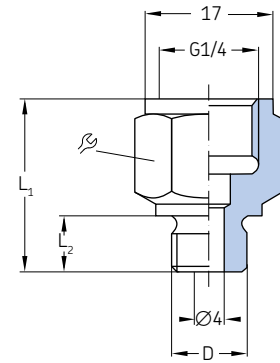

Order number	Designation	D	L ₁	L ₂	⌀	Material	Weight	
							mm	mm
301-134	CONNECTING PIECE ST - M10×1 ZN	M10×1	23	7,5	17	Steel, galvanized	20	0.044
301-034	CONNECTING PIECE ST - M14×1,5 ZN	M14×1,5	22	9	17	Steel, galvanized	20	0.044

Reducing connectors with tapered thread for operating pressures up to 350 bar

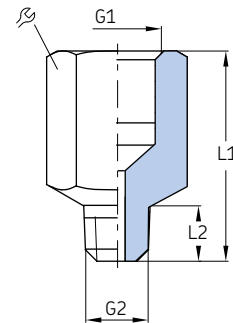

Order number	Designation	G ₁	G ₂	L ₁	L ₂	⌀	Material	Weight	
								mm	mm
304-19230-1	Adapter R1/8 AxM10x1,0 I CF	R 1/8	M10x1	18	6	13	Steel, galvanized surface	20	0.04
304-19787-1	Adapter M 8X1,0 IXM 6X1,0KA C	M6x1 tap.	M8x1	20	6	10	Steel, galvanized surface	6	0.01
304-19437-1	Adapter M 8X1,0KAXM 8X1,0 I C	M8x1 tap.	M8x1	16	6	10	Steel, galvanized surface	5	0.01
304-19548-1	Adapter M 8X1,25KAXM 8X1 I C	M8x1.25 tap.	M8x1	16	6	10	Steel, galvanized surface	10	0.02
304-19167-1	Adapter M 8X1,0 AXR1/8 I C	M8x1 tap.	G 1/8	17	6	13	Steel, galvanized surface	10	0.02
304-19509-1	Adapter M10x1,0KAXM10x1,0 I CF	M10x1 tap.	M10x1	18	4.5	13	Steel, galvanized surface	9	0.02
304-16337-1	Adapter M10x1 IxM12x1KAZ	M12x1 tap.	M10x1	18	8	17	Steel, galvanized surface	15	0.03

Adapter fittings

Elbow reducing connectors 45° with tapered thread for operating pressures up to 350 bar

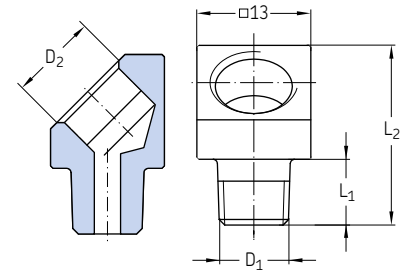

Order number	Designation	D ₁	D ₂	L ₁	L ₂	Material	Weight	
							mm	mm
432-70673-1	ELBOW FITT. 45° G 1/8I XR 1/8AK	R 1/8	G 1/8	6	20	Steel, galvanized surface	10	0.02
406-155K	ELBOW FITT. ST 45GRAD R1/8AXM10X1I CF	R 1/8	M10×1	7,5	20,5	Steel, galvanized surface	13	0.03
406-165K	ELBOW FITT. ST 45GRAD R1/8AXG1/8I CF	R 1/8	G 1/8	7,5	20,5	Steel, galvanized surface	13	0.03
432-24050-1	ELBOW FITT. 45° M 8X1,0IXM 8X1,0AK	M8×1 tap.	M8×1	5	20	Steel, galvanized surface	11	0.02
432-71483-1	ELBOW FITT. 45° M10X1IXM 8X1AK	M8×1 tap.	M10×1	5	20	Steel, galvanized surface	11	0.02
406-145K	ELBOW FITT. ST 45GRAD M8X1KAXM10X1I CF	M8×1 tap.	M10×1	7,5	21	Steel, galvanized surface	11	0.02
406-045K	ELBOW FITT. ST 45GRAD M10X1KAXM10X1I CF	M10×1 tap.	M10×1	7,5	21	Steel, galvanized surface	12	0.03
432-24051-1	ELBOW FITT. 45° M 8X1,0IXM10X1,0AK	M10×1 tap.	M8×1	5	20	Steel, galvanized surface	12	0.03

Elbow reducing connectors 90° with tapered thread for operating pressures up to 350 bar

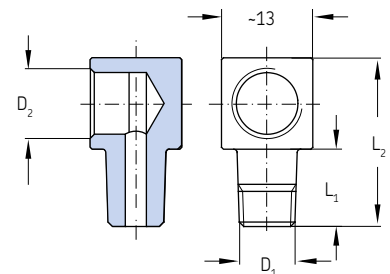

Order number	Designation	D ₁	D ₂	L ₁	L ₂	Material	Weight	
							mm	mm
432-70674-1	ELBOW FITT. ST 90° G 1/8I XR 1/8AK	R 1/8	G 1/8	9	22.5	Steel, galvanized surface	16	0.04
406-091K	ELBOW FITT. ST 90° R1/8AXG1/8I CF	R 1/8	G 1/8	11	24	Steel, galvanized surface	20	0.04
406-093K	ELBOW FITT. ST 90° R1/8AXM10X1I CF	R 1/8	M10×1	11	24	Steel, galvanized surface	16	0.04
406-094K	ELBOW FITT. ST 90° M8X1,25KAXM8X1,25I CF	M8×1.25 tap.	M8×1.25	11	24	Steel, galvanized surface	11	0.02
406-089K	ELBOW FITT. ST 90° M8X1KAXM10X1I CF	M8×1 tap.	M10×1	11	24	Steel, galvanized surface	15	0.03
406-090K	ELBOW FITT. ST 90° M10X1KAXM10X1I CF	M10×1 tap.	M10×1	11	24	Steel, galvanized surface	16	0.04
406-092K	ELBOW FITT. ST 90° M10X1KAXM10X1I CF	M10×1 tap.	M10×1	17	30	Steel, galvanized surface	20	0.04
432-24043-1	ELBOW FITT. ST 90° M 8X1,0IXM 8X1,0AK	M8×1 tap.	M8×1	5	20	Steel, galvanized surface	12	0.03
432-24052-1	ELBOW FITT. ST 90° M 8X1,0IXM10X1,0AK	M10×1 tap.	M8×1	5	20	Steel, galvanized surface	14	0.03

Adapter fittings

Reducing connectors RI with cylindrical thread for operating pressures up to 400 bar

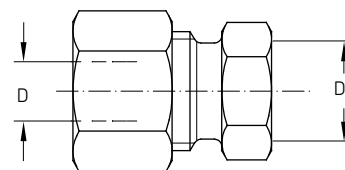

Order number	Designation	Tube ØD	ØD ₁	L ₁	L ₂	R	Material	Operating pressure max.		Weight	
								bar	psi	g	lb
Steel galvanized											
222-12578-5	BUSHING ST RI G 1/8XG 1/4 CF	G 1/8	G 1/4	31	8	19	Steel galvanized	400	5 800	42	0.09
222-12521-5	BUSHING ST RI G 1/4XG 1/8 CF	G 1/4	G 1/8	28	12	19	Steel galvanized	400	5 800	38	0.08
222-12521-6	BUSHING ST RI G 1/4XG 3/8 CF	G 1/4	G 3/8	36	12	24	Steel galvanized	400	5 800	69	0.15
222-12521-4	BUSHING ST RI G 1/4XG 1/2 CF	G 1/4	G 1/2	40	12	30	Steel galvanized	400	5 800	116	0.26
222-13678-2	BUSHING ST RI G 3/8XG 1/8 CF	G 3/8	G 1/8	22.5	12	22	Steel galvanized	400	5 800	39	0.09
222-12578-4	BUSHING ST RI G 3/8XG 1/4 CF	G 3/8	G 1/4	36	12	22	Steel galvanized	400	5 800	68	0.15
222-12578-8	BUSHING ST RI G 3/8XG 1/2 CF	G 3/8	G 1/2	41	12	30	Steel galvanized	400	5 800	125	0.28
222-12578-3	BUSHING ST RI G 3/8XG 3/4 CF	G 3/8	G 3/4	44	12	36	Steel galvanized	315	4 570	183	0.40
222-12521-2	BUSHING ST RI G 1/2XG 1/4 CF	G 1/2	G 1/4	24	14	27	Steel galvanized	315	4 570	56	0.12
96-3102-0058	BUSHING ST RI G 1/2XG 1/8 CF	G 1/2	G 1/8	24	14	27	Steel galvanized	400	5 800	66	0.15
222-12599-2	BUSHING ST RI G 1/2XG 3/8 CF	G 1/2	G 3/8	36	14	27	Steel galvanized	315	4 570	94	0.21
222-12047-2	BUSHING ST RI G 1/2XG 3/4 CF	G 1/2	G 3/4	46	14	36	Steel galvanized	315	4 570	182	0.40
222-12599-3	BUSHING ST RI G 1/2XG 1 CF	G 1/2	G 1	49	14	41	Steel galvanized	315	4 570	221	0.49
222-12578-2	BUSHING ST RI G 1/2XG 1 1/4 CF	G 1/2	G 1 1/4	53	14	55	Steel galvanized	160	2 320	482	1.06
222-13678-1	BUSHING ST RI G 3/4XG 1/4 CF	G 3/4	G 1/4	26	16	32	Steel galvanized	315	4 570	103	0.23
222-12578-9	BUSHING ST RI G 3/4XG 3/8 CF	G 3/4	G 3/8	26	16	32	Steel galvanized	315	4 570	87	0.19
222-12047-8	BUSHING ST RI G 3/4XG 1/2 CF	G 3/4	G 1/2	41	16	32	Steel galvanized	315	4 570	143	0.32
222-12047-4	BUSHING ST RI G 3/4XG 1 CF	G 3/4	G 1	51	16	41	Steel galvanized	315	4 570	235	0.52
96-3129-0058	BUSHING ST RI G 3/4XG 1 1/4 CF	G 3/4	G 1 1/4	55	16	55	Steel galvanized	160	2 320	481	1.06
222-12599-9	BUSHING ST RI G 1XG 1/2 CF	G 1	G 1/2	29	18	41	Steel galvanized	315	4 570	157	0.35
222-13678-4	BUSHING ST RI G 1XG 3/8 CF	G 1	G 3/8	29	18	41	Steel galvanized	315	4 570	179	0.39
96-3106-0058	BUSHING ST RI G 1XG 1/4 CF	G 1	G 1/4	29	18	41	Steel galvanized	315	4 570	195	0.43
222-12599-5	BUSHING ST RI G 1XG 3/4 CF	G 1	G 3/4	47	18	41	Steel galvanized	315	4 570	278	0.61
222-13670-1	BUSHING ST RI G 1XG 1 1/4 CF	G 1	G 1 1/4	57	18	55	Steel galvanized	160	2 320	530	1.17
96-3133-0058	BUSHING ST RI G 1XG 1 1/2 CF	G 1	G 1 1/2	59	18	60	Steel galvanized	160	2 320	585	1.29
222-13678-8	BUSHING ST RI G 1 1/4XG 1/2 CF	G 1 1/4	G 1/2	32	20	50	Steel galvanized	160	2 320	308	0.68
222-12521-8	BUSHING ST RI G 1 1/4XG 3/4 CF	G 1 1/4	G 3/4	32	20	50	Steel galvanized	160	2 320	267	0.59
222-12599-6	BUSHING ST RI G 1 1/4XG 1 CF	G 1 1/4	G 1	32	20	50	Steel galvanized	160	2 320	458	1.01
222-11053-1	BUSHING ST RI G 1 1/2XG 1/2 CF	G 1 1/2	G 1/2	36	22	55	Steel galvanized	160	2 320	477	1.05
96-3112-0058	BUSHING ST RI G 1 1/2XG 3/4 CF	G 1 1/2	G 3/4	36	22	55	Steel galvanized	160	2 320	402	0.89
222-13678-3	BUSHING ST RI G 1 1/2XG 1 CF	G 1 1/2	G 1	36	22	55	Steel galvanized	160	2 320	337	0.74
96-3136-0058	BUSHING ST RI G 1 1/2XG 1 1/4 CF	G 1 1/2	G 1 1/4	58	22	55	Steel galvanized	160	2 320	542	1.20
96-3137-0058	BUSHING ST RI G 2XG 1 1/2 CF	G 2	G 1 1/2	62	24	70	Steel galvanized	160	2 320	990	2.18
Stainless steel											
222-13618-1	BUSHING VA RI G 1/8XG 1/4	G 1/8	G 1/4	31	8	19	Stainless steel	400	5 800	42	0.09
222-10365-3	BUSHING VA RI G 1/4XG 1/8	G 1/4	G 1/8	28	12	19	Stainless steel	400	5 800	38	0.08
222-13618-5	BUSHING VA RI G 1/4XG 1/2	G 1/4	G 1/2	40	12	30	Stainless steel	400	5 800	116	0.26
222-14180-7	BUSHING VA RI G 3/8XG 1/4	G 3/8	G 1/4	36	12	22	Stainless steel	400	5 800	68	0.15
222-13618-2	BUSHING VA RI G 3/8XG 1/2	G 3/8	G 1/2	41	12	30	Stainless steel	400	5 800	125	0.28
222-14180-3	BUSHING VA RI G 1/2XG 1/4	G 1/2	G 1/4	24	14	27	Stainless steel	315	4 570	56	0.12
222-14180-6	BUSHING VA RI G 1/2XG 3/8	G 1/2	G 3/8	36	14	27	Stainless steel	315	4 570	94	0.21
222-14180-9	BUSHING VA RI G 3/4XG 3/8	G 3/4	G 3/8	26	16	32	Stainless steel	315	4 570	87	0.19
222-13618-3	BUSHING VA RI G 3/4XG 1/2	G 3/4	G 1/2	41	16	32	Stainless steel	315	4 570	143	0.32
222-14180-5	BUSHING VA RI G 1XG 3/4	G 1	G 3/4	47	18	41	Stainless steel	315	4 570	278	0.61

Adapter fittings

Screw plugs VSTI

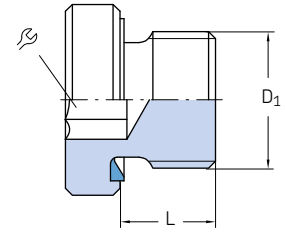

Order number	Designation	Tube Ø/D	D ₁	L	ϕ	Material	Operating pressure max.		Weight	
							bar	psi	g	lb
Steel galvanized										
466-419-001	PLUG 6-SOCK ST VSTI G1/8 -ED	G 1/8	14	8	5	Steel, galvanized	400	5 800	8	0.02
223-13702-1	PLUG 6-SOCK ST VSTI G 1/4 -ED CF	G 1/4	19	12	6	Steel, galvanized	400	5 800	20	0.04
223-13702-7	PLUG 6-SOCK ST VSTI G 1/2 -ED CF	G 1/2	27	14	10	Steel, galvanized	400	5 800	51	0.11
223-13702-6	PLUG 6-SOCK ST VSTI G 3/4 -ED CF	G 3/4	32	16	12	Steel, galvanized	400	5 800	79	0.17
223-10530-4	PLUG 6-SOCK ST VSTI G1 -ED CF	G 1	39,9	16	17	Steel, galvanized	400	5 800	130	0.29
466-429-001	PLUG 6-SOCK ST VSTI M8X1 -ED	M8x1 mm	12	8	4	Steel, galvanized	400	5 800	7	0.02
466-431-001	PLUG 6-SOCK ST VSTI M10X1 -ED	M10x1 mm	14	8	5	Steel, galvanized	400	5 800	8	0.02
466-439-001	PLUG 6-SOCK ST VSTI M18X1.5 -ED CF	M18x1,5 mm	23,9	14	8	Steel, galvanized	400	5 800	32	0.07
Stainless steel										
223-13702-5	PLUG 6-SOCK VA VSTI G1/4 -ED	G 1/4	19	12	6	Stainless steel	400	5 800	20	0.04
223-13702-9	PLUG 6-SOCK VA VSTI G1/2 -ED	G 1/2	27	14	10	Stainless steel	400	5 800	51	0.11

Vent plugs with profile seal acc. to ISO 9974-2

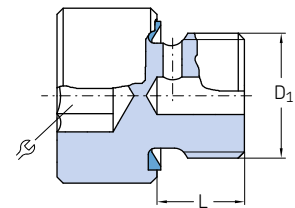

Order number	Designation	D ₁	L	ϕ	Material	Operating pressure max.		Weight	
						bar	psi	g	lb
466-431-006	PLUG ST M10X1 CF	M10x1	7	10	Steel, galvanized			10	0.02
466-431-005	PLUG ST M10X1 CF	M10x1	7	5	Steel, galvanized			10	0.02
466-431-009	PLUG ST G 1/8 CF	G 1/8	7	5	Steel, galvanized			11	0.02

Adapter fittings

Banjo fittings, rotatable

91308

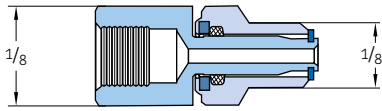

223-12567-1

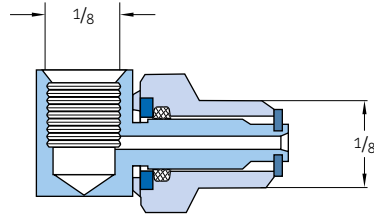

626-25702-1

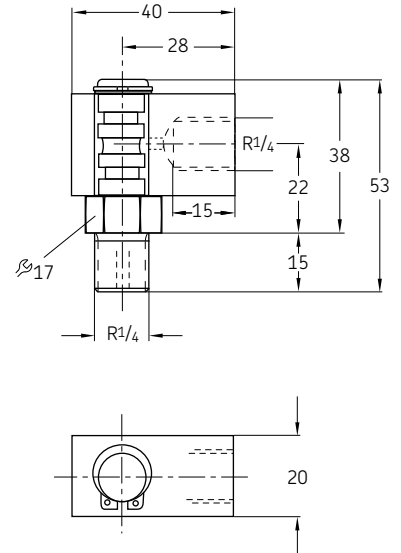

Order number	Designation	Tube Ø	Ø		Speed max.	Operation pressure		Material	Weight	
			mm	in		in	min ⁻¹		bar	psi
91308	Straight swivel 1/8 NPT	—	1/8 NPT	1/8 NPT	1	50	725	Steel galvanized	20	0.04
223-12567-1	Swivel 90° 1/8 NPT	—	1/8 NPT	1/8 NPT	1	50	725	Steel galvanized	40	0.08
626-25702-1	Swivel R1/4XR1/4 MS	—	R1/4 male	R1/4 female	1	200	2 900	Brass	102	0.22

626-2...

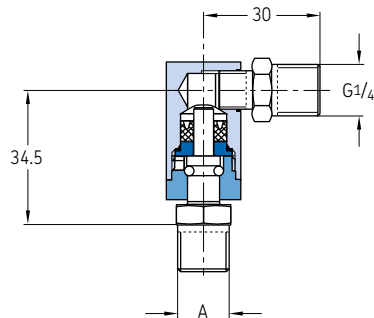

626-25720-2

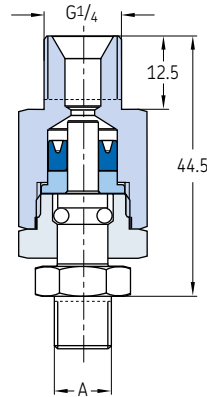

626-26696-2

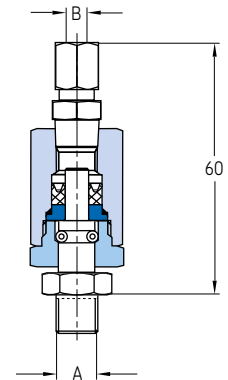

Order number	Designation	Tube Ø	Ø		Speed max.	Operation pressure		Material	Weight	
			mm	in		in	min ⁻¹		bar	psi
626-25716-2	Swivel 90° G1/4AxG1/4A F	—	G1/4 male	G1/4 male	80	100	1 450	Steel galvanized	105	0.23
626-25540-2	Swivel 90° G1/4AxG1/8A F	—	G1/4 male	G1/8 male	80	100	1 450	Steel galvanized	105	0.23
626-26700-2	Swivel 90° G1/8AxD 4 F	4	—	G1/8 male	80	100	1 450	Steel galvanized	95	0.21
626-25438-2	Swivel 90° G1/8AxD 6 F	6	—	G1/8 male	80	100	1 450	Steel galvanized	100	0.22
626-26701-2	Swivel 90° G1/4AxD 4 F	4	—	G1/4 male	80	100	1 450	Steel galvanized	105	0.23
626-25717-2	Swivel 90° G1/4AxD 6 F	6	—	G1/4 male	80	100	1 450	Steel galvanized	102	0.22
626-25720-2	Swivel straight G1/8AxG1/4A CF	—	G1/8	G1/4	80	100	1 450	Steel galvanized	75	0.16
626-26696-2	Swivel straight G1/8AXD 4 CF	4	—	G1/8	80	100	1 450	Steel galvanized	105	0.23

Adapter fittings

Banjo fittings, rotatable

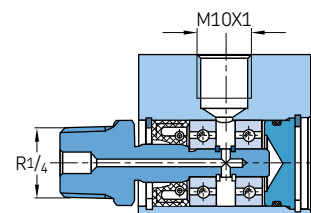

Order number	Designation	Tube ØD	Thread ₁	Thread ₂	Speed max.	Oil pressure max.		Air pressure max.		Material	Weight	
						bar	psi	bar	psi		g	lb
		mm	mm	mm	min ⁻¹	bar	psi	bar	psi		g	lb
DLY930-2	Rotating joint	8	G 1/4 A	M14x1,5	1400	20 ¹⁾	290	8	116	brass	246	0.54
DLY931	Rotating joint	8	R 1/8 tap.	M14x1,5	1400	20 ¹⁾	290	8	116	brass	244	0.54
DLY932	Rotating joint	6	R1/4	M10x1	1400	5	72	-	-	Aluminium	65	0.14

Quick connectors



Description

SKF quick connectors are the faster alternative when it comes to connecting pipes. Push-in type connectors are available for fast establishment of secure connections. Simply plug the end of the line into the pre-installed connector – all done! No wrench is required. Connections can be made more easily and quickly, especially in difficult-to-access areas. Push-in type fittings can be used to connect the entire system of lines from the pump to the metering devices, pressure switches, etc. – all the way to the lubrication points. The fittings feature internal claws to hold the tubing tight, even at 350 bar. They are equally suitable for plastic and steel tubing. Two versions of quick connectors are offered by SKF:

- Single-seal quick connectors (350 bar) suitable for grease lubrication systems
- Triple-seal quick connectors (300 bar) suitable for oil and grease lubrication systems

Features and benefits

- Fast and virtually leakage-free connection
- No wrench tightening required
- Time savings due to easy and quick system assembly
- Connections in systems (without system pressure) can be easily opened and reclosed again
- Protection against penetrating dirt



Applications

- Food and beverage industry
- Renewable energy industry
- Construction machinery
- Asphalt mixing plants
- Agricultural machines
- Material handling
- On-road vehicles
- Etc.

Quick connectors

Single-seal quick connectors (350 bar)

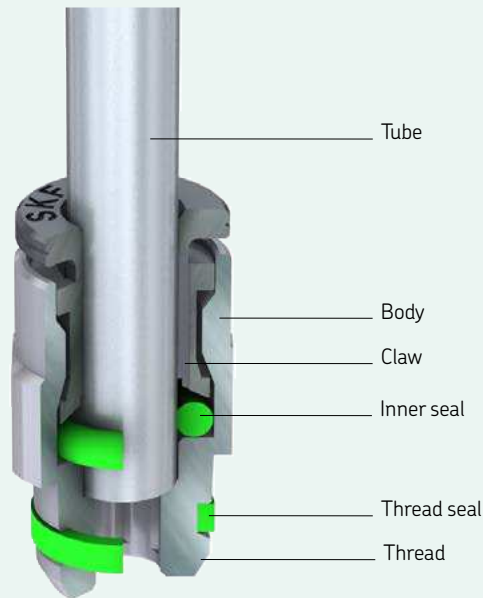

Description

SKF single-seal quick connectors have one O-ring. They are suitable for grease lubrication systems with system pressures up to 350 bar.

Features and benefits

- Suitable for grease
- Smaller
- Protection caps needed under harsh conditions
- Max. operating pressure 350 bar
- For tube $\varnothing 6$ mm
- Marking of the collet: with groove
- Surface: nickel-plated C5M (seawater proof)
- Pipe sealing, expansion ring for collet chuck
- Plastic pipes can be used without claw groove
- Thread sealing via spring ring

Single-seal quick connectors

Straight screw-in connectors

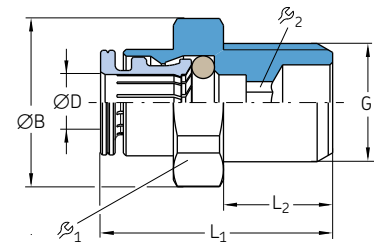

Order number	Designation	Tube		ØB	L ₁	L ₂	β ₁	β ₂	Seal	Material	Operating pressure max.		Weight (100 pcs)	
		ØD	G								bar	psi	g	lb
226-14139-1	Push-in fitt. GEZM 6-1/4	6	G 1/4	18,5	12	25,5	17	4	NBR	Brass, nickel-plated	350	5 080	2 000	4.41

Straight screw-in connectors with PTFE threaded seal

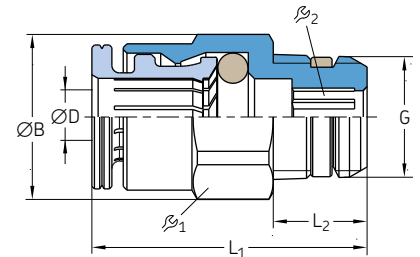

Order number	Designation	Tube		ØB	L ₁	L ₂	β ₁	β ₂	Seal	Material	Operating pressure max.		Weight (100 pcs)	
		ØD	G								bar	psi	g	lb
226-14111-1	Push-in fitt. GEKM S 6-1/8	6	R 1/8	13,2	7,5	22	12	4	NBR	Brass, nickel-plated	350	5 080	1 000	2.21
226-10205-5	Push-in fitt. GEZM S 6-1/4	6	G 1/4	15,2	7	21,5	14	4	NBR	Brass, nickel-plated	350	5 080	1 400	3.09

Single-seal quick connectors

Adapters with tapered thread

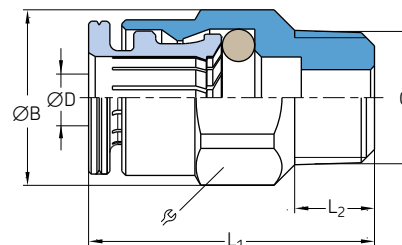

Order number	Designation	Tube		ØB	L ₁	L ₂	R	Seal	Material	Operating pressure max.		Weight (100 pcs)	
		ØD	G							bar	psi	g	lb
		mm	mm	mm	mm	mm	mm			bar	psi	g	lb
226-14111-4	Push-in fitt. GEKM 6-M6×1	6	M6×1 tap.	13,2	24	6	12	NBR	Brass, nickel-plated	350	5 080	900	1.98
226-14111-2	Push-in fitt. GEKM 6-M8×1	6	M8×1 tap.	13,2	23	6	12	NBR	Brass, nickel-plated	350	5 080	1 000	2.21
226-14111-3	Push-in fitt. GEKM 6-M10×1	6	M10×1 tap.	13,2	21,5	6	12	NBR	Brass, nickel-plated	350	5 080	1 000	2.21
226-10622-8	Push-in fitt. GEKM 6-1/8	6	R 1/8	13,2	22	7,5	12	NBR	Brass, nickel-plated	350	5 080	1 000	2.21

Banjo fittings with tapered thread

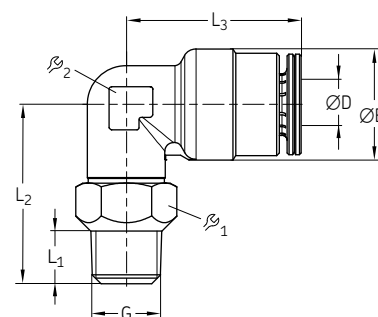

Order number	Designation	Tube		ØB	L ₁	L ₂	L ₃	R ₁	R ₂	Seal	Material	Operating pressure max.		Weight (100 pcs)	
		ØD	G									bar	psi	g	lb
		mm	mm	mm	mm	mm	mm	mm	mm			bar	psi	g	lb
226-14157-3	Push-in fitt. WEDKM 6-M 6×1	6	M6×1 tap.	12,7	6	20,5	20	10	9	NBR	Brass, nickel-plated	350	5 080	1 600	3,53
226-14157-1	Push-in fitt. WEDKM 6-M 8×1	6	M8×1 tap.	12,7	6	20,5	20	10	9	NBR	Brass, nickel-plated	350	5 080	1 600	3,53
226-14157-2	Push-in fitt. WEDKM 6-M10×1	6	M10×1 tap.	12,7	6	20,5	20	12	9	NBR	Brass, nickel-plated	350	5 080	2 000	4,41
226-13756-9	Push-in fitt. WEDKM 6-1/8	6	R 1/8	12,7	7,5	21	20	12	9	NBR	Brass, nickel-plated	350	5 080	1 900	4,19

Single-seal quick connectors

Elbows with tapered thread

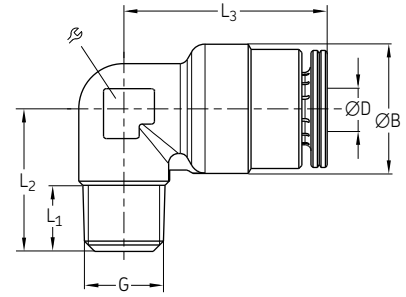

Order number	Designation	Tube		ØB	L ₁	L ₂	L ₃	ϕ	Seal	Material	Operating pressure max.		Weight (100 pcs)	
		ØD	G								bar	psi	g	lb
		mm	mm	mm	mm	mm	mm	mm			bar	psi	g	lb
226-14123-4	Push-in fit. WEKM 6-M 6×1	6	M6×1 tap.	12,7	6	15	20	9	NBR	Brass, nickel-plated	350	5 080	1 400	3.09
226-14123-2	Push-in fit. WEKM 6-M 8×1	6	M8×1 tap.	12,7	6,5	14	20	9	NBR	Brass, nickel-plated	350	5 080	1 300	2.87
226-14123-3	Push-in fit. WEKM 6-M10×1	6	M10×1 tap.	12,7	6	14	20	9	NBR	Brass, nickel-plated	350	5 080	1 500	3.31
226-14123-5	Push-in fit. WEKM 6-1/8	6	R 1/8	12,7	7,5	15,5	20	9	NBR	Brass, nickel-plated	350	5 080	1 400	3.09
226-13753-9 1)	Push-in fit. WEKM S 6-1/8	6	R 1/8	12,7	7,5	15,5	20	9	NBR	Brass, nickel-plated	350	5 080	1 400	3.09

1) with threaded seal

Banjo fittings with O-ring threaded seal

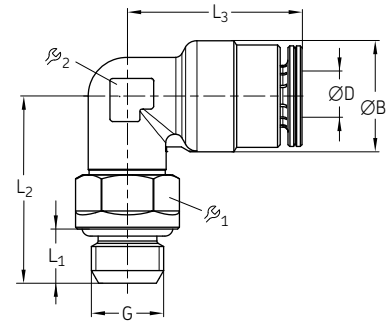

Order number	Designation	Tube		ØB	L ₁	L ₂	L ₃	ϕ ₁	ϕ ₂	Seal	Material	Operating pressure max.		Weight (100 pcs)	
		ØD	G									bar	psi	g	lb
		mm	mm	mm	mm	mm	mm	mm	mm			bar	psi	g	lb
226-11313-8	Push-in fit. WEDZM 6-1/4	6	G 1/4	12,7	7	23	20	15	9	NBR	Brass, nickel-plated	350	5 080	2 500	5.51
226-11313-9	Push-in fit. WEDZM 6-1/8	6	G 1/8	12,7	6	21	20	12	9	NBR	Brass, nickel-plated	350	5 080	2 300	5.07
226-11315-1	Push-in fit. WEDZM 6-M 6×1	6	M6×1	12,7	7	21	20	10	9	NBR	Brass, nickel-plated	350	5 080	2 300	5.07
226-11315-2	Push-in fit. WEDZM 6-M 8×1	6	M8×1	12,7	7	22	20	10	9	NBR	Brass, nickel-plated	350	5 080	2 400	5.29

Single-seal quick connectors

Banjo fittings with PTFE threaded seal

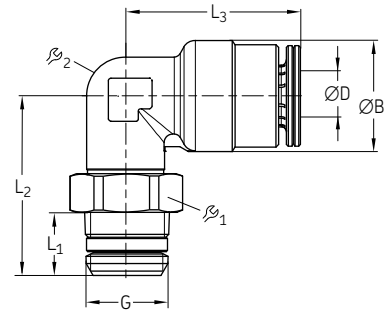

Order number	Designation	Tube		ØB	L ₁	L ₂	L ₃	β ₁	β ₂	Seal	Material	Operating pressure max.		Weight (100 pcs)	
		ØD	G									bar	psi	g	lb
226-14157-4	Push-in fitt. WEDKM S 6-1/4	6	R 1/4	12,7	11	24,5	20,1	14	9	NBR	Brass, nickel-plated	350	5 080	2 000	4.41
226-14157-5	Push-in fitt. WEDKM S 6-1/8	6	R 1/8	12,7	7,5	21	20	12	9	NBR	Brass, nickel-plated	350	5 080	1 900	4.19

Banjo fittings with hexagon socket and O-ring threaded seal

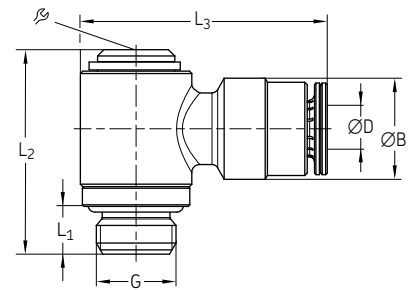

Order number	Designation	Tube		ØB	L ₁	L ₂	L ₃	β	Seal	Material	Operating pressure max.		Weight (100 pcs)	
		ØD	G								bar	psi	g	lb
226-10223-2	Push-in fitt. WEDZM 6-1/8	6	G 1/8	12,7	6	25,7	24,1	5	NBR	Brass, nickel-plated	350	5 080	2 700	5.95
226-10223-4	Push-in fitt. WEDZM 6-M 8×1	6	M 8×1	12,7	6	26	24	5	NBR	Brass, nickel-plated	350	5 080	2 500	5.51
226-10223-6	Push-in fitt. WEDZM 6-M10×1	6	M10×1	12,7	6	25,7	24,1	5	NBR	Brass, nickel-plated	350	5 080	2 600	5.73

Single-seal quick connectors

T-Screw-in connector

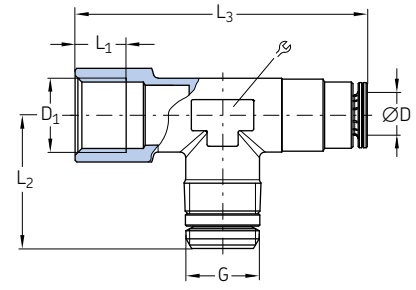

Order number	Designation	Tube		D ₁	L ₁	L ₂	L ₃	β	Seal	Material	Operating pressure max.		Weight	
		ØD	G								bar	psi	g	lb
226-14097-5	Push-in fitt. TSM S 6-1/4	6	R 1/4	G 1/4	9	23,5	51,5	14	NBR	Brass, nickel-plated	350	5 080	50	0.11

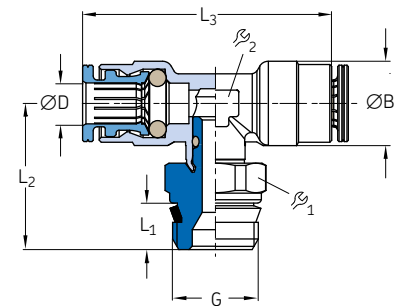

Order number	Designation	Tube		ØB	L ₁	L ₂	L ₃	β ₁	β ₂	Seal	Material	Operating pressure max.		Weight	
		ØD	G									mm	mm	mm	mm
226-10159-1	Push-in fitt. TEDZM S 6-1/8	6	G 1/8	12,7	5,5	20,3	40,2	9	9	NBR	Brass, nickel-plated	350	5 080	27	0.06
226-10159-9	Push-in fitt. TEDZM S 6-1/4	6	G 1/4	12,7	7	22	40	14	9	NBR	Brass, nickel-plated	350	5 080	35	0.08

Single-seal quick connectors

T-Connector

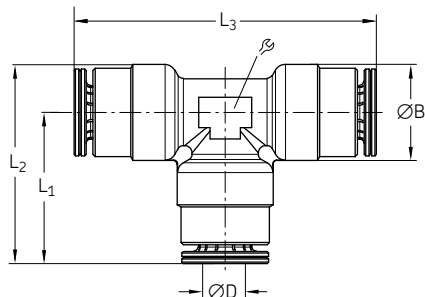

Order number	Designation	Tube		L ₁	L ₂	L ₃	⌀	Seal	Material	Operating pressure max.		Weight	
		ØD	ØB							bar	psi	g	lb
226-14097-4	Push-in fitt. TSM 6	6	12,7	20	26	40	6	NBR	Brass, nickel-plated	350	5 080	20	0,04

Straight bulkhead connectors

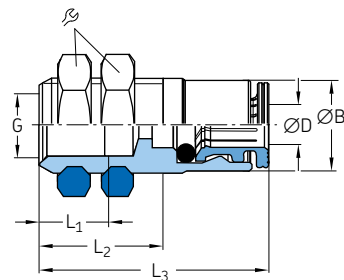

Order number	Designation	Tube		ØB	L ₁	L ₂	L ₃	⌀	Seal	Material	Operating pressure max.		Weight	
		ØD	G								bar	psi	g	lb
226-10214-4	Push-in fitt. SVM 6-G 1/8	6	G 1/8	12,5	9	17	31,6	17	NBR	Brass, nickel-plated	350	5 080	26	0,06
226-10214-7	Push-in fitt. SVM 6-M 8x1	6	M 8x1	12,5	9	17	31,5	17	NBR	Brass, nickel-plated	350	5 080	27	0,06

Single-seal quick connectors

Tube-to-tube connector

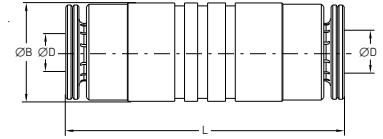

Order number	Designation	Tube			Seal	Material	Operating pressure max.		Weight	
		ØD	ØB	L			bar	psi	g	lb
		mm	mm	mm						
226-13773-4	Connector GSM 6	6	12	34	NBR	Brass, nickel-plated	350	5 080	18	0.04

Triple-seal quick connectors

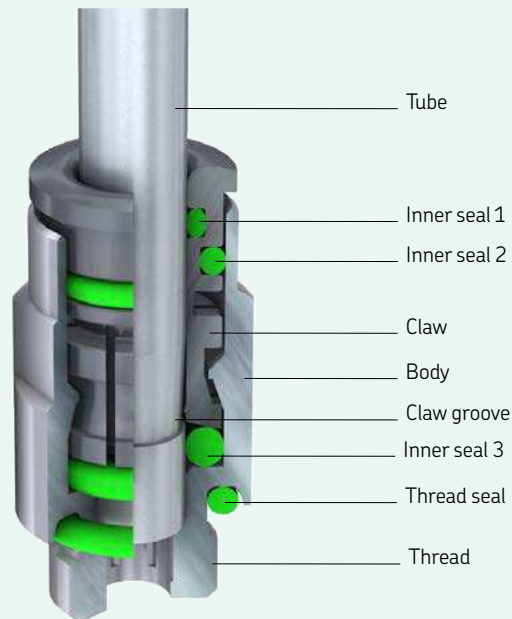

Claw grooves

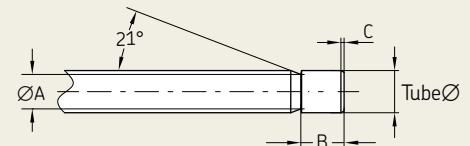

Description

SKF tripple-seal quick connectors have three O-rings. They are suitable for oil lubrication systems with system pressures up to 300 bar. For a good union, steel pipes or fittings used as hose end fittings must be prepared with a claw groove. Plastic pipes can be connected directly without an additional claw groove.

For metal pipes, a claw groove is required at the end of the pipe

Tube \varnothing	A $+0,3$	B $\pm 0,2$	C
4	3,1	5	0,3 ... 0,7
6	4,9	6,2	0,4 ... 0,9
8	6,9	6,2	0,5 ... 0,9

Tool for the production of pipe ends (cutting and groove-forming) available in the chapter tools.

Features and benefits

- Suitable for oil and fluid grease
- Better sealing by three O-rings (leakage-free)
- Max. operating pressure 300 bar
- For tube $\varnothing 4, 6$ and 8 mm
- Marking of the collet: plain
- Surface: collet nickel-plated C4
- Insertion depth for plastic and steel tubing
 - $\varnothing 4$ mm: 19 mm
 - $\varnothing 6$ mm: 22 mm
 - $\varnothing 8$ mm: 24 mm
- Reduction of bending forces
- Sealing for the pipe, expansion ring for collet chuck
- Sealing thread O-ring

Triple-seal quick connectors

Straight screw-in connectors with cylindrical thread

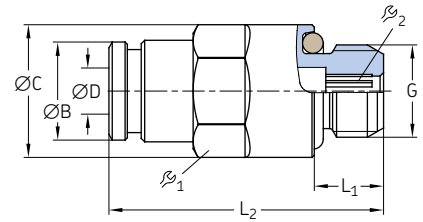

Order number	Designation	Tube		ØB	ØC	L ₁	L ₂	r ₁	r ₂	Seal	Material	Operating pressure max.		Weight (100 pcs)	
		ØD	G									bar	psi	g	lb
451-004-260-VS	Push-in fitt. GEZ 4-M6 NBR	4	M6	8,8	11,5	4,5	25	10	2,5	NBR	Brass	300	4 350	1 000	2.21
404-073-VS	Push-in fitt. GEZ 4-M6x0,75 NBR	4	M6x0,75	8,8	11,5	4,5	25,3	10	2,5	NBR	Brass	300	4 350	1 000	2.21
404-063-VS	Push-in fitt. GEZ 4-M8 NBR	4	M8	8,8	11,5	6	23,8	10	2,5	NBR	Brass	300	4 350	900	1.98
404-003-VS	Push-in fitt. GEZ 4-M8x1 NBR	4	M8x1	8,8	11,5	6	23,8	10	2,5	NBR	Brass	300	4 350	900	1.98
404-003-S8-VS	Push-in fitt. GEZ 4-M8x1 FPM	4	M8x1	8,8	11,5	6	23,8	10	2,5	FPM	Brass	300	4 350	1 000	2.21
404-006-VS	Push-in fitt. GEZ 4-M10x1 NBR	4	M10x1	8,8	13,5	6	23,8	12	2,5	NBR	Brass	300	4 350	1 400	3.09
404-006-S8-VS	Push-in fitt. GEZ 4-M10x1 FPM	4	M10x1	8,8	13,5	6	23,8	12	2,5	FPM	Brass	300	4 350	1 400	3.09
404-040-VS	Push-in fitt. GEZ 4-G1/8 NBR	4	G 1/8	8,8	13,5	6	23,8	12	2,5	NBR	Brass	300	4 350	1 400	3.09
406-158-VS	Push-in fitt. GEZ 6-M8x1 NBR	6	M8x1	11,7	13,2	6	30,5	12	3	NBR	Brass	300	4 350	1 500	3.31
406-004-VS	Push-in fitt. GEZ 6-M10x1 NBR	6	M10x1	11,7	13,5	6	27	12	4	NBR	Brass	300	4 350	1 500	3.31
406-004-S8-VS	Push-in fitt. GEZ 6-M10x1 FPM	6	M10x1	11,7	13,5	6	27	12	4	FPM	Brass	300	4 350	1 400	3.09
456-004-VS	Push-in fitt. GEZ 6-G1/8 NBR	6	G 1/8	11,7	13,5	6	27	12	4	NBR	Brass	300	4 350	1 400	3.09
456-004-S8-VS	Push-in fitt. GEZ 6-G1/8 FPM	6	G 1/8	11,7	13,5	6	27	12	4	FPM	Brass	300	4 350	1 400	3.09
406-054-VS	Push-in fitt. GEZ 6-G1/4 NBR	6	G 1/4	11,7	16,4	7	28	12	4	NBR	Brass	300	4 350	1 900	4.19
406-162-VS	Push-in fitt. GEZ 6-M12x1 NBR	6	M12x1	11,7	15,4	7	28	14	4	NBR	Brass	300	4 350	2 200	4.85
406-162-S8-VS	Push-in fitt. GEZ 6-M12x1 FPM	6	M12x1	11,7	15,4	7	28	14	4	FPM	Brass	300	4 350	2 400	5.29
408-004-VS	Push-in fitt. GEZ 8-M10x1 NBR	8	M10x1	13,9	15,2	6	32,3	14	5	NBR	Brass	300	4 350	2 000	4.41
408-004-S8-VS	Push-in fitt. GEZ 8-M10x1 FPM	8	M10x1	13,9	15,2	6	32,3	14	5	FPM	Brass	300	4 350	2 000	4.41
408-162-VS	Push-in fitt. GEZ 8-M12x1 NBR	8	M12x1	13,9	15,2	7	32,8	14	6	NBR	Brass	300	4 350	2 300	5.07
408-162-S8-VS	Push-in fitt. GEZ 8-M12x1 FPM	8	M12x1	13,9	15,2	7	32,8	14	6	FPM	Brass	300	4 350	2 000	4.41
408-054-VS	Push-in fitt. GEZ 8-G1/4 NBR	8	G 1/4	13,9	16,4	7	30,8	15	6	NBR	Brass	300	4 350	3 000	6.62

Straight screw-in connectors with tapered thread

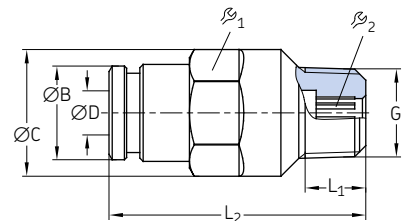

Order number	Designation	Tube		ØB	ØC	L ₁	L ₂	r ₁	r ₂	Seal	Material	Operating pressure max.		Weight (100 pcs)	
		ØD	G									bar	psi	g	lb
451-004-462-VS	Push-in fitt. GEK 4-M6K NBR	4	M6 tap.	8,8	11,5	5,5	25,8	10	2,5	NBR	Brass	300	4 350	900	1.98
451-004-471-VS	Push-in fitt. GEK 4-M6x0,75K NBR	4	M6x0.75 tap.	8,8	11,5	5,5	25,8	10	2,5	NBR	Brass	300	4 350	900	1.98
451-004-498-VS	Push-in fitt. GEK 4-M8x1K NBR	4	M8x1 tap.	8,8	11,5	5,5	23,3	10	2,5	NBR	Brass	300	4 350	900	1.98
451-004-518-VS	Push-in fitt. GEK 4-M10x1K NBR	4	M10x1 tap.	8,8	11,5	5,5	22,8	10	2,5	NBR	Brass	300	4 350	1 100	2.43
404-673K-V1-VS	Push-in fitt. GEK 4-1/4-28 SAE LT NBR	4	1/4-28 SAE LT	8,8	11,5	5,1	26,3	10	2,5	NBR	Brass	300	4 350	1 000	2.21
404-040K-V1-VS	Push-in fitt. GEK 4-1/8 NPTF NBR	4	1/8 NPTF	8,8	11,5	8	24,8	10	2,5	NBR	Brass	300	4 350	1 200	2.65
451-006-468-VS	Push-in fitt. GEK 6-M6K NBR	6	M6 tap.	11,7	13,5	5,5	30	12	2,5	NBR	Brass	300	4 350	1 400	3.09
451-006-498-VS	Push-in fitt. GEK 6-M8x1K NBR	6	M8x1 tap.	11,7	13,5	5,5	29,5	12	4	NBR	Brass	300	4 350	1 400	3.09
451-006-518-VS	Push-in fitt. GEK 6-M10x1K NBR	6	M10x1 tap.	11,7	13,5	5,5	27	12	4	NBR	Brass	300	4 350	1 500	3.31
406-423W-VS	Push-in fitt. GEK 6-R1/8 NBR	6	R 1/8	11,7	13,5	6,5	28,5	12	4	NBR	Brass	300	4 350	1 500	3.31
406-423N-VS	Push-in fitt. GEK 6-1/8 NPT NBR	6	1/8 NPT	11,7	13,5	7,5	28,5	12	4	NBR	Brass	300	4 350	1 600	3.53

Triple-seal quick connectors

Tube to tube connectors

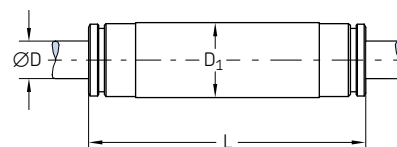

Order number	Designation	Tube			Material	Operating pressure max.		Weight (100 pcs)	
		ØD	D ₁	L		bar	psi	g	lb
		mm	mm	mm					
454-504-041-VS	Connector GS 4 NBR	4	10	38,5	Brass	300	4 350	1 500	3.31
406-426-VS	Connector GS 6 NBR	6	12	44,5	Brass	300	4 350	2 000	4.41

Banjo fittings with banjo bolt and cylindrical thread

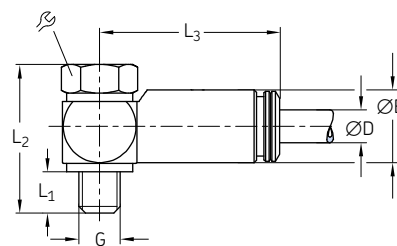

Order number	Designation	Tube		ØB	L ₁	L ₂	L ₃	⌀	Seal	Material	Operating pressure max.		Weight (100 pcs)	
		ØD	G								bar	psi	g	lb
		mm	mm	mm	mm	mm	mm	mm						
504-161-VS	Banjo fitting SWVZ-4-M6 NBR	4	M6	8,8	5	19,5	22,3	9	NBR	Brass	300	4350	1300	2.87
504-401-S1-VS	Banjo fitting SWVZ-4-M5 NBR	4	M5	8,8	5	18	21,8	8	NBR	Brass	300	4 350	1 100	2.43
504-411-VS	Banjo fitting SWVZ-4-M8 NBR	4	M8	8,8	7	20	23,8	12	NBR	Brass	300	4 350	1 700	3.75
504-401-VS	Banjo fitting SWVZ-4-M8×1 NBR	4	M8×1	8,8	7	20	23,8	12	NBR	Brass	300	4 350	1 800	3.97
504-103-VS	Banjo fitting SWVZ-4-M10×1 NBR	4	M10×1	8,8	7	22,5	24,8	14	NBR	Brass	300	4 350	2 400	5.29
445-519-041-VS	Banjo fitting SWVZ-4-G1/8 NBR	4	G 1/8	8,8	7	22,5	24,8	14	NBR	Brass	300	4 350	2 400	5.29

Triple-seal quick connectors

Elbows with tapered thread

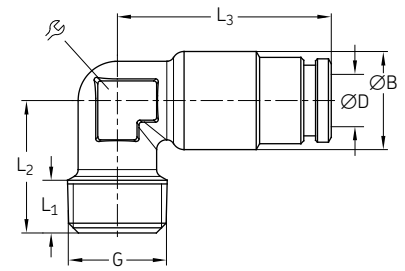

Order number	Designation	Tube		D ₁	L ₁	L ₂	L ₃	⌀	Seal	Material	Operating pressure max.		Weight (100 pcs)	
		ØD	G								bar	psi	g	lb
		mm	mm	mm	mm	mm	mm	mm						
453-004-471-VS	Push-in fitt. WEK 4-M6K NBR	4	M6 tap.	10	6	14	21,8	9	NBR	Brass	300	4 350	1100	2.43
453-004-471-S8-VS	Push-in fitt. WEK 4-M6K FPM	4	M6 tap.	10	6	14	21,8	9	FPM	Brass	300	4 350	1200	2.65
504-201-VS	Push-in fitt. WEK 4-M8×1K NBR	4	M8×1 tap.	10	6	13,5	21,8	9	NBR	Brass	300	4 350	1100	2.43
504-201-S8-VS	Push-in fitt. WEK 4-M8×1K FPM	4	M8×1 tap.	10	6	13,5	21,8	9	FPM	Brass	300	4 350	1200	2.65
504-202-VS	Push-in fitt. WEK 4-M10×1K NBR	4	M10×1 tap.	10	6	13,5	21,8	9	NBR	Brass	300	4 350	1100	2.43
504-202-S8-VS	Push-in fitt. WEK 4-M10×1K FPM	4	M10×1 tap.	10	6	13,5	21,8	9	FPM	Brass	300	4 350	1300	2.87
514-018-VS	Push-in fitt. WEK 4-R1/8 NBR	4	R1/8	10	7,5	15	21,8	9	NBR	Brass	300	4 350	1200	2.65
514-018-S8-VS	Push-in fitt. WEK 4-R1/8 FPM	4	R1/8	10	7,5	15	21,8	9	FPM	Brass	300	4 350	1300	2.87
504-200K-V1-VS	Push-in fitt. WEK 4-1/4-28SAE LT NBR	4	1/4-28SAE LT	10	5,1	15,5	21,8	9	NBR	Brass	300	4 350	1200	2.65
514-018K-V1-VS	Push-in fitt. WEK 4-1/8NPT NBR	4	1/8 NPT	10	7	15	21,8	9	NBR	Brass	300	4 350	1300	2.87
453-006-468-VS	Push-in fitt. WEK 6-M6K NBR	6	M6 tap.	12,5	6	15	26	10	NBR	Brass	300	4 350	2 000	4.41
453-006-468-S8-VS	Push-in fitt. WEK 6-M6K FPM	6	M6 tap.	12,5	6	15	26	10	FPM	Brass	300	4 350	1800	3.97
506-508-VS	Push-in fitt. WEK 6-M8×1K NBR	6	M8×1 tap.	12,5	6,5	14	26	10	NBR	Brass	300	4 350	1600	3.53
506-508-S8-VS	Push-in fitt. WEK 6-M8×1K FPM	6	M8×1 tap.	12,5	6,5	14	26	10	FPM	Brass	300	4 350	1800	3.97
506-510-VS	Push-in fitt. WEK 6-M10×1K NBR	6	M10×1 tap.	12,5	6	14	26	10	NBR	Brass	300	4 350	1600	3.53
506-510-S8-VS	Push-in fitt. WEK 6-M10×1K FPM	6	M10×1 tap.	12,5	6	14	26	10	FPM	Brass	300	4 350	1700	3.75
506-512-VS	Push-in fitt. WEK 6-M12×1K NBR	6	M12×1 tap.	12,5	7	15	26	10	NBR	Brass	300	4 350	1800	3.97
506-511-VS	Push-in fitt. WEK 6-R1/8 NBR	6	R1/8	12,5	8,5	16,5	26	10	NBR	Brass	300	4 350	1700	3.75
506-511-S8-VS	Push-in fitt. WEK 6-R1/8 FPM	6	R1/8	12,5	8,5	16,5	26	10	FPM	Brass	300	4 350	1800	3.97
506-511K-V1-VS	Push-in fitt. WEK 6-1/8NPT NBR	6	1/8 NPT	12,5	8,5	16,5	26	10	NBR	Brass	300	4 350	1900	4.19
453-006-651-VS	Push-in fitt. WEK 6-R1/4 NBR	6	R1/4	12,5	11,5	19,5	26	10	NBR	Brass	300	4 350	1900	4.19

Triple-seal quick connectors

Banjo fittings with cylindrical thread

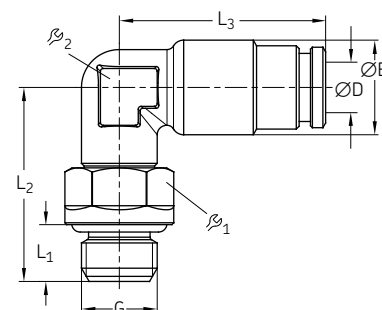

Order number	Designation	Tube		$\varnothing B$	L_1	L_2	L_3	φ_1	φ_2	Seal	Material	Operating pressure max.		Weight (100 pcs)	
		$\varnothing D$	G									bar	psi	g	lb
504-100-VS	Push-in fitt. WEDZ 4-M6×1 NBR	4	M6×1	10	4,5	17,5	21,8	9	9	NBR	Brass	300	4 350	1 200	2.65
504-101-VS	Push-in fitt. WEDZ 4-M8×1 NBR	4	M8×1	10	6	20,5	21,8	10	9	NBR	Brass	300	4 350	1 500	3.31
504-101-S8-VS	Push-in fitt. WEDZ 4-M8×1 FPM	4	M8×1	10	6	20,5	21,8	10	9	FPM	Brass	300	4 350	1 500	3.31
504-102-VS	Push-in fitt. WEDZ 4-M10×1 NBR	4	M10×1	10	6	20,5	21,8	12	9	NBR	Brass	300	4 350	2 000	4.41
504-102-S8-VS	Push-in fitt. WEDZ 4-M10×1 FPM	4	M10×1	10	6	20,5	21,8	12	9	FPM	Brass	300	4 350	2 000	4.41
504-108-VS	Push-in fitt. WEDZ 4-G1/8 NBR	4	G 1/8	10	6	20,5	21,8	12	9	NBR	Brass	300	4 350	1 800	3.97
504-108-S8-VS	Push-in fitt. WEDZ 4-G1/8 FPM	4	G 1/8	10	6	20,5	21,8	12	9	FPM	Brass	300	4 350	1 900	4.19
506-139-VS	Push-in fitt. WEDZ 6-M8×1 NBR	6	M8×1	12,5	6	21	26	10	10	NBR	Brass	300	4 350	1 900	4.19
506-139-S8-VS	Push-in fitt. WEDZ 6-M8×1 FPM	6	M8×1	12,5	6	21	26	10	10	FPM	Brass	300	4 350	2 000	4.41
506-140-VS	Push-in fitt. WEDZ 6-M10×1 NBR	6	M10×1	12,5	6	21	26	12	10	NBR	Brass	300	4 350	2 200	4.85
506-140-S8-VS	Push-in fitt. WEDZ 6-M10×1 FPM	6	M10×1	12,5	6	21	26	12	10	FPM	Brass	300	4 350	2 200	4.85
506-108-VS	Push-in fitt. WEDZ 6-G1/8 NBR	6	G 1/8	12,5	6	21	26	12	10	NBR	Brass	300	4 350	2 200	4.85
506-108-S8-VS	Push-in fitt. WEDZ 6-G1/8 FPM	6	G 1/8	12,5	6	21	26	12	10	FPM	Brass	300	4 350	2 300	5.07
506-142-VS	Push-in fitt. WEDZ 6-M12×1 NBR	6	M12×1	12,5	7	23	26	14	10	NBR	Brass	300	4 350	2 700	5.95
506-142-S8-VS	Push-in fitt. WEDZ 6-M12×1 FPM	6	M12×1	12,5	7	23	26	14	10	FPM	Brass	300	4 350	2 700	5.95
506-143-VS	Push-in fitt. WEDZ 6-G1/4 FPM	6	G 1/4	12,5	7	23	26	15	10	NBR	Brass	300	4 350	2 900	6.39
508-142-VS	Push-in fitt. WEDZ 8-M12×1 NBR	8	M12×1	14,5	7	23	28,8	14	12	NBR	Brass	300	4 350	3 200	7.06
508-142-S8-VS	Push-in fitt. WEDZ 8-M12×1 FPM	8	M12×1	14,5	7	23	28,8	14	12	FPM	Brass	300	4 350	3 200	7.06

Triple-seal quick connectors

Banjo fittings with tapered thread

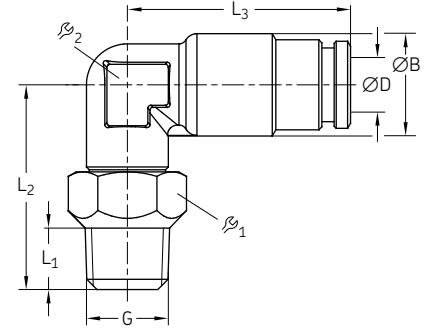

Order number	Designation	Tube		ØB	L ₁	L ₂	L ₃	ϕ ₁	ϕ ₂	Seal	Material	Operating pressure max.		Weight (100 pcs)	
		ØD	G									bar	psi	g	lb
		mm	mm	mm	mm	mm	mm	mm	mm			bar	psi	g	lb
455-546-048-VS	Push-in fitt. WEDK 4-M6K NBR	4	M6 tap.	10	6	20	21,8	10	9	NBR	Brass	300	4 350	1 400	3.09
455-546-048-S8-VS	Push-in fitt. WEDK 4-M6K FPM	4	M6 tap.	10	6	20	21,8	10	9	FPM	Brass	300	4 350	1 500	3.31
455-529-048-VS	Push-in fitt. WEDK 4-M8×1K NBR	4	M8×1 tap.	10	6	20	21,8	10	9	NBR	Brass	300	4 350	1 600	3.53
455-529-048-S8-VS	Push-in fitt. WEDK 4-M8×1K FPM	4	M8×1 tap.	10	6	20	21,8	10	9	FPM	Brass	300	4 350	1 600	3.53
455-531-048-VS	Push-in fitt. WEDK 4-M10×1K NBR	4	M10×1 tap.	10	6	20	21,8	12	9	NBR	Brass	300	4 350	1 800	3.97
455-531-048-S8-VS	Push-in fitt. WEDK 4-M10×1K FPM	4	M10×1 tap.	10	6	20	21,8	12	9	FPM	Brass	300	4 350	1 800	3.97
455-569-048-VS	Push-in fitt. WEDK 4-R1/8 NBR	4	R 1/8	10	7,5	20,5	21,8	12	9	NBR	Brass	300	4 350	2 000	4.41
455-529-068-VS	Push-in fitt. WEDK 6-M8×1K NBR	6	M8×1 tap.	12,5	6	20,5	26	10	10	NBR	Brass	300	4 350	2 000	4.41
455-529-068-S8-VS	Push-in fitt. WEDK 6-M8×1K FPM	6	M8×1 tap.	12,5	6	20,5	26	10	10	FPM	Brass	300	4 350	2 000	4.41
455-531-068-VS	Push-in fitt. WEDK 6-M10×1K NBR	6	M10×1 tap.	12,5	6	20,5	26	12	10	NBR	Brass	300	4 350	2 300	5.07
455-531-068-S8-VS	Push-in fitt. WEDK 6-M10×1K FPM	6	M10×1 tap.	12,5	6	20,5	26	12	10	FPM	Brass	300	4 350	2 300	5.07
455-546-068-VS	Push-in fitt. WEDK 6-M6×1K NBR	6	M6×1 tap.	12,5	6	20,5	26	10	10	NBR	Brass	300	4 350	2 000	4.41
455-565-068-VS	Push-in fitt. WEDK 6-R1/4 FPM	6	R 1/4	12,5	11	24,5	26	14	10	FPM	Brass	300	4 350	2 900	6.39

Locking Pin

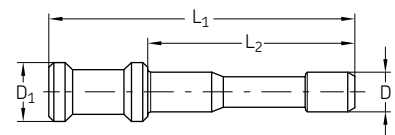

Order number	Designation	Tube		L ₁	L ₂	Material	Operating pressure max.		Weight (100 pcs)	
		Ø	D ₁				mm	mm	bar	psi
		mm	mm	mm	mm					
450-204-002	Plug pin D4 MS for push-in fitt.	4	6	31	21	Brass	300	4 350	300	0.66
450-206-002	Plug pin D6 MS for push-in fitt.	6	8	37	25	Brass	300	4 350	800	1.76

Manifolds



Description

Manifolds are designed for the installation of one or several metering devices, restrictors or lubrication point lines and enable direct main line connection. They are often used with the 341, 351 and 361 series single-line metering devices or VD screw-in flow restrictors. Manifolds are available for various main-line connections, such as M8×1, M10×1 and M14×1.5 threads. The number of outlet ports varies from 1 to 10 (on request up to 20) with threads of M8×1 and M10×1. The seal is made via an O-ring or sealing washer (copper).

Features and benefits

- Wide selection of connection options and variants
- Available in aluminum, galvanized steel available on request
- Easy and quick system extension/reduction

Applications

- Automotive Industry
- General industry
- Machine tools
- Etc.

Manifolds

Metering device manifolds

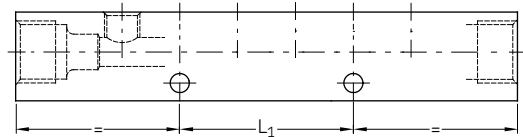
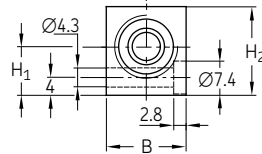
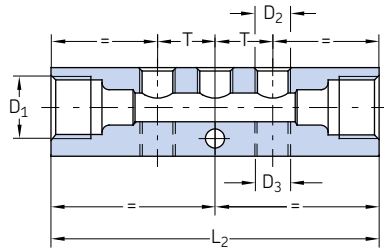

Order number	Designation	Main tube port tube Ø	D ₁	D ₂	D ₃	L ₁	L ₂	H ₁	H ₂	B	T	Material	Weight	
													mm	mm
VL-01EAM3	Manifold AL M10×1, 1xM10×1	6	M10×1	1x M10×1	-	-	41	11	20	18	-	Aluminum alloy	40	0.09
VL-02EAM3	Manifold AL M10×1, 2xM10×1	6	M10×1	2x M10×1	-	-	58	11	20	18	17	Aluminum alloy	50	0.11
VL-03EAM3	Manifold AL M10×1, 3xM10×1	6	M10×1	3x M10×1	-	-	75	11	20	18	17	Aluminum alloy	60	0.13
VL-04EAM3	Manifold AL M10×1, 4xM10×1	6	M10×1	4x M10×1	-	34	92	11	20	18	17	Aluminum alloy	78	0.17
VL-05EAM3	Manifold AL M10×1, 5xM10×1	6	M10×1	5x M10×1	-	51	109	11	20	18	17	Aluminum alloy	90	0.20
VL-06EAM3	Manifold AL M10×1, 6xM10×1	6	M10×1	6x M10×1	-	68	126	11	20	18	17	Aluminum alloy	100	0.22
VL-08EAM3	Manifold AL M10×1, 8xM10×1	6	M10×1	8x M10×1	-	52	160	11	20	18	17	Aluminum alloy	135	0.30
VL-10EAM3	Manifold AL M10×1, 10xM10×1	6	M10×1	10x M10×1	-	136	194	11	20	18	17	Aluminum alloy	162	0.36
322-861	Manifold AL M10×1, 2x1xM10×1	6	M10×1	1x M10×1	1x M10×1	-	41	11	20	18	-	Aluminum alloy	30	0.07
324-861	Manifold AL M10×1, 2x2xM10×1	6	M10×1	2x M10×1	2x M10×1	-	58	11	20	18	18	Aluminum alloy	50	0.11
326-663	Manifold AL M10×1, 2x3xM10×1	6	M10×1	3x M10×1	3x M10×1	52	77	11	17	18	18	Aluminum alloy	60	0.13
328-861	Manifold AL M10×1, 2x4xM10×1	6	M10×1	4x M10×1	4x M10×1	34	92	11	20	18	18	Aluminum alloy	70	0.15
330-861	Manifold AL M10×1, 2x5xM10×1	6	M10×1	5x M10×1	5x M10×1	51	109	11	20	18	18	Aluminum alloy	80	0.18
332-861	Manifold AL M10×1, 2x6xM10×1	6	M10×1	6x M10×1	6x M10×1	68	126	11	20	18	18	Aluminum alloy	96	0.21
334-861	Manifold AL M10×1, 2x7xM10×1	6	M10×1	7x M10×1	7x M10×1	85	143	11	20	18	18	Aluminum alloy	108	0.24
336-861	Manifold AL M10×1, 2x8xM10×1	6	M10×1	8x M10×1	8x M10×1	102	160	11	20	18	18	Aluminum alloy	128	0.28
338-861	Manifold AL M10×1, 2x9xM10×1	6	M10×1	9x M10×1	9x M10×1	119	177	11	20	18	18	Aluminum alloy	137	0.30
340-861	Manifold AL M10×1, 2x10xM10×1	6	M10×1	10x M10×1	10x M10×1	136	194	11	20	18	18	Aluminum alloy	140	0.31
VL-01DAM3	Manifold AL M10×1, 1xM8×1	6	M10×1	1x M8×1	-	-	39	10,5	17	13	-	Aluminum alloy	20	0.04
VL-02DAM3	Manifold AL M10×1, 2xM8×1	6	M10×1	2x M8×1	-	-	52	10,5	17	13	13	Aluminum alloy	30	0.07
VL-03DAM3	Manifold AL M10×1, 3xM8×1	6	M10×1	3x M8×1	-	-	65	10,5	17	13	13	Aluminum alloy	30	0.07
VL-04DAM3	Manifold AL M10×1, 4xM8×1	6	M10×1	4x M8×1	-	-	78	10,5	17	13	13	Aluminum alloy	38	0.08
VL-05DAM3	Manifold AL M10×1, 4xM8×1	6	M10×1	5x M8×1	-	-	91	10,5	17	13	13	Aluminum alloy	40	0.09
VL-06DAM3	Manifold AL M10×1, 6xM8×1	6	M10×1	6x M8×1	-	52	104	11	20	18	13	Aluminum alloy	50	0.11
VL-08DAM3	Manifold AL M10×1, 8xM8×1	6	M10×1	8x M8×1	-	52	130	10,5	17	13	13	Aluminum alloy	65	0.14
VL-10DAM3	Manifold AL M10×1, 10xM8×1	6	M10×1	10x M8×1	-	78	156	10,5	17	13	13	Aluminum alloy	80	0.18
321-581	Manifold AL M14×1.5, 1xM8×1	8	M14×1,5	1x M8×1	-	-	48	11	20	18	-	Aluminum alloy	40	0.09
322-581	Manifold AL M14×1.5, 2xM8×1	8	M14×1,5	2x M8×1	-	-	61	11	20	18	13	Aluminum alloy	47	0.10
323-581	Manifold AL M14×1.5, 3xM8×1	8	M14×1,5	3x M8×1	-	-	74	11	20	18	13	Aluminum alloy	50	0.11
324-581	Manifold AL M14×1.5, 4xM8×1	8	M14×1,5	4x M8×1	-	-	87	11	20	18	13	Aluminum alloy	55	0.12
325-581	Manifold AL M14×1.5, 5xM8×1	8	M14×1,5	5x M8×1	-	-	74	11	20	18	13	Aluminum alloy	70	0.15
326-581	Manifold AL M14×1.5, 6xM8×1	8	M14×1,5	6x M8×1	-	39	113	11	20	18	13	Aluminum alloy	90	0.20
328-581	Manifold AL M14×1.5, 8xM8×1	8	M14×1,5	8x M8×1	-	65	139	11	20	18	13	Aluminum alloy	110	0.24
330-581	Manifold AL M14×1.5, 10xM8×1	8	M14×1,5	10x M8×1	-	91	165	11	20	18	13	Aluminum alloy	135	0.30

Tubes and hoses



Description

Pipe and hose lines are an important connecting element in all lubrication systems. The lubricant is transported by them from the pump via the metering device to the lubrication points.

The following chapter lists the suitable pipe and hose material for all SKF lubrication systems.

The following criteria must be considered when selecting:

- Pipe dimension (inside diameter and wall thickness): Selection according to the occurring pressures and pressure drops
- Material or surface protection of the steel pipes

Material for steel pipes: precision hydraulic pipe seamless to EN 10305-4 in galvanized Cr-6-free or stainless steel material 1.4571 for aggressive conditions (sea water, cleaning agents, paper machines).

Material for plastic pipes Polyamide: PA12H (natural, semi-rigid), PA12HL (black, semi-rigid), PA12PH (natural, flexible), PA12PHL (black, flexible).

Features and benefits

- Reliable and long-term lubricant transfer solutions for low-, medium- and high-pressure lubrication systems
- Quick installation as pipes/hoses are pre-filled with lubricant
- Wide range of available versions

Applications

- Paper and packaging industry
- Food and beverage industry
- Construction machines
- Agriculture machines
- Oil and gas industry
- Renewable energy
- Material handling
- On-road trucks
- Etc.

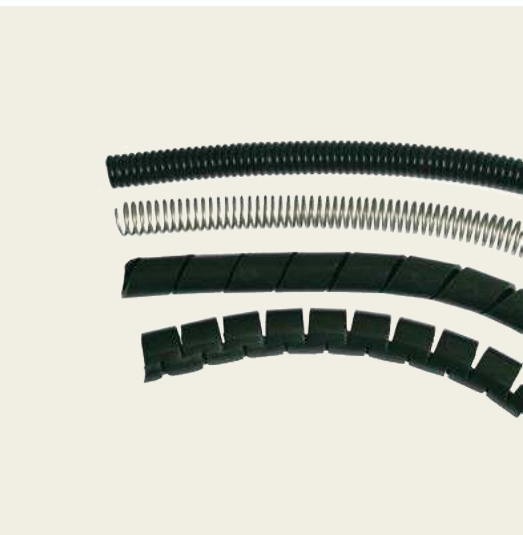

Fixing material

SKF offers a wide range of tube-fixing material, such as fixing clips, pipe brackets, cable straps, mounting bases and fixing bolts, which are suitable for tubes typically used in lubrication systems. For more details, please see the chapter on fixing material starting page 116.

Tools

SKF has a variety of tools that help assemble tubes and hoses in all kinds of systems. You can find the following tools detailed in the chapter on tools:

- Tube bending device (for the bending of metal tubes)
- Pipe cutter (for cutting metal tubes and producing a claw groove for quick connection fittings)

For more information, please see the chapter on tools on page 152.

Tube protections

SKF offers a range of solutions for tube protection including coils, protective helixes or corrugated hoses. For more details, please see page 103.

Tubes and hoses

Plastic tubing

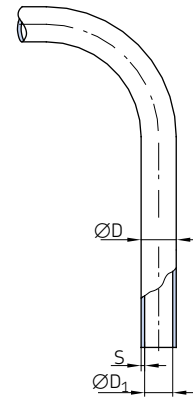

Order number	Designation	Tube outside ØD	Wall thickness S	Min. bending radius ¹⁾ R	Operating pressure max. at 20°C/68°F		Material	Weight (100 m)	
					bar	psi		kg	lb
Plastic tubing semirigid (without plasticizer)									
WVN715-R02.5X0.5	TUBE, PA12H 2.5X0.5 NATUR	2,5	0,5	25	66	957	PA12H	0,33	0.73
WVN715-R04X0.85	TUBE, PA12H 4.0X0.85 NATUR	4	0,85	38	72	1 044	PA12H	0,88	1.94
WVN715R04X0.85+A89	TUBE, PA12HL 4.0X0.85 BLACK	4	0,85	38	72	1 044	PA12HL	0,88	1.94
112-35127-7	TUBE, PA12HL 4.0X1.0 BLACK	4	1	30	80	1 160	PA12HL	0,9	1.98
112-35127-5	TUBE, PA12HL 4.0X1.0 NATUR	4	1	30	80	1 160	PA12HL	0,9	1.98
WVN715-R06X1	TUBE, PA12H 6.0X1.0 NATUR	6	1	63	53	768	PA12H	1,61	3.55
WVN715-R06X1.25	TUBE, PA12H 6.0X1.25 NATUR	6	1,25	63	70	1 015	PA12H	1,92	4.23
WVN715R06X1.25+A89	TUBE, PA12HL 6.0X1.25 BLACK	6	1,25	63	70	1 015	PA12HL	2,16	4.76
112-35127-2	TUBE, PA12HL 6.0X1.5 BLACK	6	1,5	40	89	1 290	PA12HL	2,29	5.05
WVN715-R08x1.25	TUBE, PA12H 8.0X1.25 NATUR	8	1,25	76	49	710	PA12H	2,73	6.02
Plastic tubing flexible (containing plasticizer)									
WVN716-R04X0.85	TUBE, PA12PH 4.0X0.85 NATUR	4	0,85	38	36	522	PA12PH	0,53	1.17
WVN716R04X0.85+A89	TUBE, PA12PHL 4.0X0.85 BLACK	4	0,85	38	36	522	PA12PHL	0,53	1.17
112-35225-4	TUBE, PA12PHL 4.0X1.0 BLACK	4	1	27	40	580	PA12PHL	0,63	1.39
WVN716-R06X1.25	TUBE, PA12PH 6.0X1.25 NATUR	6	1,25	63	35	507	PA12PH	2	4.41
WVN716R06X1.25+A89	TUBE, PA12PHL 6.0X1.25 BLACK	6	1,25	63	35	507	PA12PHL	2	4.41
WVN716-R08X1.25	TUBE, PA12PH 8.0X1.25 NATUR	8	1,25	80	25	362	PA12PH	2,8	6.17

¹⁾ without bending device
²⁾ the permissible burst pressure is lower at higher temperatures (→ pressure utilization factor table).

Pressure utilization factor

Temperature up to °C	Pressure efficiency %
23	100
30	83
40	72
50	64
60	57
70	52
80	47

The pressure utilization factor indicates the percentage utilization of effective stress available in the specified temperature ranges, based on 23 °C.

Technical Data

Material	PA 12 H	PA 12 HL (black tubing)
	polyamide 12, semirigid, unplasticized as per DIN 73378, stabilized against heat and aging.	polyamide 12, semirigid, unplasticized as per DIN 73378, stabilized against light, heat and aging.
	PA 12 PH	PA 12 PHL (black tubing)
	polyamide 12, flexible, containing plasticizer as per DIN 73378, stabilized against heat and aging.	polyamide 12, flexible, containing plasticizer as per DIN 73378, stabilized against light, heat, and aging.
Temperature range	-60 to +80 °C	-60 to +80 °C

Tube protections



Order number	Designation	Ø	Material	Weight	
				g	lb
		mm			
Corrugated tube					
982-760-120	TUBE, CORRUGATED PA6 NW8	8,4	Polyamide 6, black colour	20	0.04
982-760-130	TUBE, CORRUGATED PA6 NW10	10	Polyamide 6, black colour	26	0.06
982-760-160	TUBE, CORRUGATED PA6 NW12	12,3	Polyamide 6, black colour	34	0.07
Spring coil					
982-760-122	SPRING COIL DI6.1XD1.2 1.4310	6,1	Stainless steel	64	0.14
982-760-132	SPRING COIL DI10.6XD1.2 1.4310	10,6	Stainless steel	64	0.14
982-760-142	SPRING COIL DI13.5XD1.5 1.4310	12,5	Stainless steel	64	0.14
111-35306-5	SPRING COIL DI17XD1.8 1.4310	17	Stainless steel	290	0.64
Plastic helix					
113-35075-2	PLASTIC HELIX GR. 6 BLACK	5-20	Polyethylene, black colour	13	0.03
113-35075-3	PLASTIC HELIX GR.12 BLACK	9-30	Polyethylene, black colour	48	0.11
Spiral hose					
982-760-102	SPIRAL HOSE, PP NW8 SLOTTED	6-9	Polypropylene	25	0.06
982-760-172	SPIRAL HOSE, PP NW15 SLOTTED	10-16	Polypropylene	100	0.22

Tubes and hoses

Steel tubing

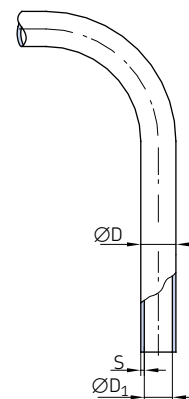

Order number	Designation	ØD	D ₁	Material	Operating pressure max.		Weight	
					bar	psi	kg/m	lb/m
		mm	mm					
982-120-041	TUBE, E235+N NBK D 4,0X 0,7 C	4	2,6	Steel tubing, galvanized surface (Cr-6 free)	368	5 340	0,063	0.14
982-120-040	TUBE, E235+N NBK D 4,0X 1,0 C	4	2	Steel tubing, galvanized surface (Cr-6 free)	500	7 250	0,074	0.16
982-120-061	TUBE, E235+N NBK D 6,0X 0,7 C	6	4,6	Steel tubing, galvanized surface (Cr-6 free)	333	4 830	0,12	0.26
105-35251-1	TUBE, ST37.4 NBK D 6,0X 1,0 C	6	4	Steel tubing, galvanized surface (Cr-6 free)	372	5 390	0,123	0.27
105-35251-3	TUBE, ST37.4 NBK D 8,0X 1,0 CF	8	6	Steel tubing, galvanized surface (Cr-6 free)	333	4 830	0,173	0.38
982-120-100	TUBE, E235+N NBK D 10,0X 1,0 C	10	8	Steel tubing, galvanized surface (Cr-6 free)	282	4 090	0,222	0.49
105-35025-5	TUBE, ST37.4 NBK D 10,0x 1.5 CF	10	7	Steel tubing, galvanized surface (Cr-6 free)	373	5 410	0,314	0.69
105-35134-3	TUBE, ST37.4 NBK D 12,0X 1,5 C	12	9	Steel tubing, galvanized surface (Cr-6 free)	353	5 120	0,388	0.86
105-35134-9	TUBE, ST37.4 NBK D 15,0X 1,5 C	15	12	Steel tubing, galvanized surface (Cr-6 free)	282	4 090	0,499	1.1
105-35183-3	TUBE, ST37.4 NBK D 16,0X 2,0 C	16	12	Steel tubing, galvanized surface (Cr-6 free)	353	5 120	0,691	1.52
982-120-180	TUBE, E235+N NBK D 18,0X 1,0 C	18	15	Steel tubing, galvanized surface (Cr-6 free)	157	2 280	0,61	1.35
105-35134-1	TUBE, ST37.4 NBK D 20,0X 2,0 C	20	16	Steel tubing, galvanized surface (Cr-6 free)	282	4 090	0,888	1.96
105-35308-1	TUBE, ST37.4 NBK D 28,0X 2,0 CF	28	24	Steel tubing, galvanized surface (Cr-6 free)	201	2 910	1,282	2.83
105-35134-4	TUBE, ST37.4 NBK D 30,0X 3,0 C	30	24	Steel tubing, galvanized surface (Cr-6 free)	282	4 090	1,998	4.41

Stainless steel tubing

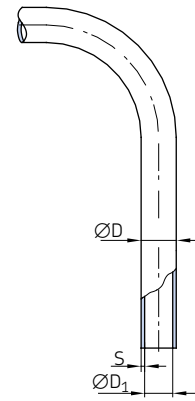

Order number	Designation	ØD	D ₁	Material	Operating pressure max.		Weight	
					bar	psi	kg/m	lb/m
		mm	mm					
D1127R02.5x0.5+A46	TUBE,NIRO 1.4301 D 2,5X0,5	2,5	1,5	Stainless steel (material 1.4301/1.4306)	386	5 600	0,042	0.09
DIN2462-R04x1+A46	TUBE,NIRO 1.4301 D 4,0X1,0	4	2	Stainless steel (material 1.4301/1.4306)	466	6 760	0,075	0.17
106-35203-4	TUBE,NIRO 1.4571 D 6,0X1,0	6	4	Stainless steel 1.4571	426	6 180	0,125	0.28
106-35203-3	TUBE,NIRO 1.4571 D 8,0X1,0	8	6	Stainless steel 1.4571	368	5 340	0,169	0.37
DIN2462-R010x1+A46	TUBE,NIRO 1.4301 D 10,0X1,0	10	8	Stainless steel (material 1.4301/1.4306)	231	3 350	0,225	0.5
106-35203-2	TUBE,NIRO 1.4571 D 10,0X1,5	10	7	Stainless steel 1.4571	389	5 640	0,319	0.7
106-35203-1	TUBE,NIRO 1.4571 D 20,0X2,0	20	16	Stainless steel 1.4571	294	4 260	0,901	1.99
106-35292-2	TUBE,NIRO 1.4571 D 22,0X2,0	22	18	Stainless steel 1.4571	267	3 870	1,002	2.21
106-35292-1	TUBE,NIRO 1.4571 D 28,0X2,0	28	24	Stainless steel 1.4571	210	3 050	1,302	2.87
106-35203-7	TUBE,NIRO 1.4571 D 30,0X3,0	30	24	Stainless steel 1.4571	294	4 260	2,028	4.47
106-35231-1	TUBE,NIRO 1.4301 D 6,0X1,0	6	4	Stainless steel 1.4301	400	5 800	0,123	0.27
106-35231-2	TUBE,NIRO 1.4301 D 8,0X1,0	8	6	Stainless steel 1.4301	310	4 500	0,17	0.37
106-35231-3	TUBE,NIRO 1.4301 D 10,0X1,5	10	7	Stainless steel 1.4301	365	5 290	0,315	0.69
106-35231-6	TUBE,NIRO 1.4301 D 20,0X2,0	20	16	Stainless steel 1.4301	253	3 670	0,888	1.96
106-35267-4	TUBE,NIRO 1.4301 D 22,0X2,0	22	18	Stainless steel 1.4301	232	3 360	0,986	2.17

Tubes and hoses

Low-pressure hoses for main lines max. 45 bar

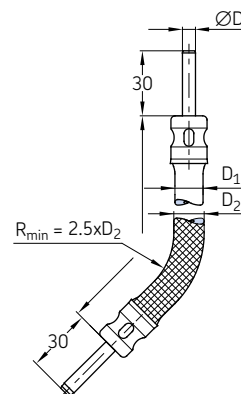

Order number	Designation ¹⁾	Tube ØD	Length	Rubber ØD ₁	Metal braided D ₂	Max. increase in volume at 80 bar	Weight	
		mm	mm	mm	mm	cm ³ /m	g	lb
Low-pressure hoses with tube stud Ø4 mm								
714-180	HOSE CR 45 DN3X180,STU 4	4	180	11	–	2,5	39	0.09
714-220	HOSE CR 45 DN3X 220,STU 4	4	220	11	–	2,5	43	0.09
714-260	HOSE CR 45 DN3X 260,STU 4	4	260	11	–	2,5	48	0.11
714-300	HOSE CR 45 DN3X 300,STU 4	4	300	11	–	2,5	57	0.13
714-380	HOSE CR 45 DN3X 380,STU 4	4	380	11	–	2,5	61	0.13
714-420	HOSE CR 45 DN3X 420,STU 4	4	420	11	–	2,5	70	0.15
714-450	HOSE CR 45 DN3X 450,STU 4	4	450	11	–	2,5	74	0.16
714-500	HOSE CR 45 DN3X 500,STU 4	4	500	11	–	2,5	84	0.19
714-580	HOSE CR 45 DN3X 580,STU 4	4	580	11	–	2,5	92	0.20
Low-pressure hoses with tube stud Ø4 mm and metal braid								
714-180-M	HOSE CR 45 DN3X180,STU 4, MET.BRAID.	4	180	11	12	2,5	56	0.12
714-260-M	HOSE CR 45 DN3X 260,STU 4, MET.BRAID.	4	260	11	12	2,5	69	0.15
714-300-M	HOSE CR 45 DN3X 300,STU 4, MET.BRAID.	4	300	11	12	2,5	75	0.17
714-400-M	HOSE CR 45 DN3X 400,STU 4, MET.BRAID.	4	400	11	12	2,5	97	0.21
714-500-M	HOSE CR 45 DN3X 500,STU 4, MET.BRAID.	4	500	11	12	2,5	119	0.26
714-580-M	HOSE CR 45 DN3X 580,STU 4, MET.BRAID.	4	580	11	12	2,5	167	0.37
Low-pressure hoses with tube stud Ø6 mm								
716-220	HOSE CR 45 DN4,5X 220,STU 6	6	220	13	–	3,6	64	0.14
716-300	HOSE CR 45 DN4,5X 300,STU 6	6	300	13	–	3,6	72	0.16
716-340	HOSE CR 45 DN4,5X 340,STU 6	6	340	13	–	3,6	79	0.17
716-380	HOSE CR 45 DN4,5X 380,STU 6	6	380	13	–	3,6	86	0.19
716-420	HOSE CR 45 DN4,5X 420,STU 6	6	420	13	–	3,6	90	0.20
716-500	HOSE CR 45 DN4,5X 500,STU 6	6	500	13	–	3,6	101	0.22
716-580	HOSE CR 45 DN4,5X 580,STU 6	6	580	13	–	3,6	128	0.28
Low-pressure hoses with tube stud Ø6 mm and metal braid								
716-300-M	HOSE CR 45 DN4,5X 300,STU6 MET.BRAID.	6	300	13	14	3,6	108	0.24
716-400-M	HOSE CR 45 DN4,5X 400,STU6 MET.BRAID.	6	400	13	14	3,6	140	0.31
716-460-M	HOSE CR 45 DN4,5X 500,STU6 MET.BRAID.	6	450	13	14	3,6	155	0.34
716-500-M	HOSE CR 45 DN4,5X 580,STU6 MET.BRAID.	6	500	13	14	3,6	165	0.36
Low-pressure hoses with tube stud Ø8 mm								
718-340	HOSE CR 45 DN6,5X 340,STU 8	8	340	15	–	4,4	117	0.26
718-450	HOSE CR 45 DN6,5X 450,STU 8	8	450	15	–	4,4	133	0.29
718-580	HOSE CR 45 DN6,5X 580,STU 8	8	580	15	–	4,4	141	0.31
Low-pressure hoses with tube stud Ø8 mm and metal braid								
718-400-M	HOSE CR 45 DN6,5X 400,STU 8, MET.BRAID.	8	400	15	16	4,4	136	0.30
718-450-M	HOSE CR 45 DN6,5X 450,STU 8, MET.BRAID.	8	450	15	16	4,4	157	0.35
718-500-M	HOSE CR 45 DN6,5X 500,STU 8, MET.BRAID.	8	500	15	16	4,4	174	0.38

¹⁾ Material hose: mineral oil resistant CR rubber inside; 2 layers of braided rayon, outside rubber conditionally oil resistant, resistant to light cracks and ozone.
Material metal braid: galvanized steel wire; tube ends: galvanized steel tubing.

Tubes and hoses

Low-pressure hoses for main lines max. 45 bar with tapered sleeve and socket union on both ends

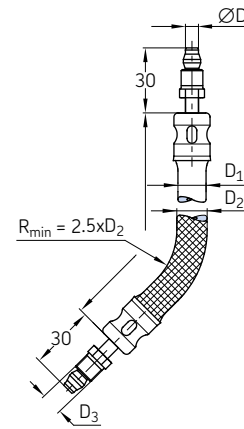

Order number	Designation ¹⁾	Tube	Length	Rubber	Metal	Thread	Max. increase in volume at 80 bar	Weight	
		ØD		ØD ₁	braided D ₂			D ₃	g
		mm	mm	mm	mm	mm	cm ³ /m		
Low-pressure hoses with tapered sleeve socket union									
714-180-K	HOSE CR 45 DN3X180,M8X1	4	180	11	-	M8x1	2,5	45	0.10
714-220-K	HOSE CR 45 DN3X 220,M8X1	4	220	11	-	M8x1	2,5	49	0.11
714-260-K	HOSE CR 45 DN3X 260,M8X1	4	260	11	-	M8x1	2,5	53	0.12
714-300-K	HOSE CR 45 DN3X 300,M8X1	4	300	11	-	M8x1	2,5	59	0.13
714-380-K	HOSE CR 45 DN3X 380,M8X1	4	380	11	-	M8x1	2,5	68	0.15
714-420-K	HOSE CR 45 DN3X 420,M8X1	4	420	11	-	M8x1	2,5	76	0.17
714-450-K	HOSE CR 45 DN3X 450,M8X1	4	450	11	-	M8x1	2,5	84	0.19
714-500-K	HOSE CR 45 DN3X 500,M8X1	4	500	11	-	M8x1	2,5	90	0.20
714-580-K	HOSE CR 45 DN3X 580,M8X1	4	580	11	-	M8x1	2,5	100	0.22
Low-pressure hoses with tapered sleeve socket union and metal braid									
714-180-MK	HOSE CR 45 DN3X180,M8X1, MET.BRAID.	4	180	11	12	M8x1	2,5	63	0.14
714-260-MK	HOSE CR 45 DN3X 260,M8X1, MET.BRAID.	4	260	11	12	M8x1	2,5	80	0.18
714-300-MK	HOSE CR 45 DN3X 300,M8X1, MET.BRAID.	4	300	11	12	M8x1	2,5	85	0.19
714-400-MK	HOSE CR 45 DN3X 400,M8X1, MET.BRAID.	4	400	11	12	M8x1	2,5	110	0.24
714-500-MK	HOSE CR 45 DN3X 500,M8X1, MET.BRAID.	4	500	11	12	M8x1	2,5	120	0.26
714-580-MK	HOSE CR 45 DN3X 580,M8X1, MET.BRAID.	4	580	11	12	M8x1	2,5	140	0.31
Low-pressure hoses with tapered sleeve socket union									
716-220-K	HOSE CR 45 DN4,5X 220,M10X1	6	220	13	-	M10x1	3,6	68	0.15
716-300-K	HOSE CR 45 DN4,5X 300,M10X1	6	300	13	-	M10x1	3,6	80	0.18
716-340-K	HOSE CR 45 DN4,5X 340,M10X1	6	340	13	-	M10x1	3,6	85	0.19
716-380-K	HOSE CR 45 DN4,5X 380,M10X1	6	380	13	-	M10x1	3,6	92	0.20
716-420-K	HOSE CR 45 DN4,5X 420,M10X1	6	420	13	-	M10x1	3,6	98	0.22
716-500-K	HOSE CR 45 DN4,5X 500,M10X1	6	500	13	-	M10x1	3,6	113	0.25
716-580-K	HOSE CR 45 DN4,5X 580,M10X1	6	580	13	-	M10x1	3,6	127	0.28
Low-pressure hoses with tapered sleeve socket union and metal braid									
716-300-MK	HOSE CR 45 DN4,5X 300,M10X1, MET.BRAID.	6	300	13	14	M10x1	3,6	110	0.24
716-400-MK	HOSE CR 45 DN4,5X 400,M10X1, MET.BRAID.	6	400	13	14	M10x1	3,6	140	0.31
716-450-MK	HOSE CR 45 DN4,5X 500,M10X1, MET.BRAID.	6	450	13	14	M10x1	3,6	160	0.35
716-500-MK	HOSE CR 45 DN4,5X 580,M10X1, MET.BRAID.	6	500	13	14	M10x1	3,6	180	0.40
Low-pressure hoses with tapered sleeve socket union									
718-340-K	HOSE CR 45 DN6,5X 400,M14X1,5	8	340	15	-	M14x1,5	4,4	116	0.26
718-450-K	HOSE CR 45 DN6,5X 450,M14X1,5	8	450	15	-	M14x1,5	4,4	147	0.32
718-580-K	HOSE CR 45 DN6,5X 500,M14X1,5	8	580	15	-	M14x1,5	4,4	164	0.36
Low-pressure hoses with tapered sleeve socket union and metal braid									
718-400-MK	HOSE CR 45 DN6,5X 400,M14X1,5, MET.BRAID.	8	400	15	16	M14x1,5	4,4	160	0.35
718-450-MK	HOSE CR 45 DN6,5X 450,M14X1,5, MET.BRAID.	8	450	15	16	M14x1,5	4,4	195	0.43
718-500-MK	HOSE CR 45 DN6,5X 500,M14X1,5, MET.BRAID.	8	500	15	16	M14x1,5	4,4	221	0.49

¹⁾ Material hose: mineral oil resistant CR rubber inside; 2 layers of braided rayon, outside rubber conditionally oil resistant, resistant to light cracks and ozone.
Material metal braid: galvanized steel wire; tube ends: galvanized steel tubing.

Tubes and hoses

Low-pressure hoses for main lines max. 45 bar with socket union on both ends and with claw groove for quick connector

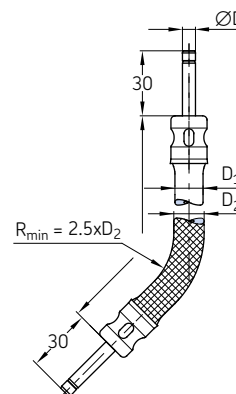

Order number	Designation ¹⁾	Tube ØD	Length	Rubber ØD ₁	Metal braided D ₂	Max. increase in volume at 80 bar	Weight
		mm	mm	mm	mm	cm ³ /m	g <i>lb</i>
Low-pressure hoses with tube stud Ø4 mm with claw groove for quick connectors							
714-180-VS	HOSE CR 45 DN3X180,VS	4	180	11	–	2,5	39 <i>0.09</i>
714-220-VS	HOSE CR 45 DN3X220,VS	4	220	11	–	2,5	43 <i>0.09</i>
714-260-VS	HOSE CR 45 DN3X260,VS	4	260	11	–	2,5	48 <i>0.11</i>
714-300-VS	HOSE CR 45 DN3X300,VS	4	300	11	–	2,5	57 <i>0.13</i>
714-380-VS	HOSE CR 45 DN3X380,VS	4	380	11	–	2,5	61 <i>0.13</i>
714-420-VS	HOSE CR 45 DN3X420,VS	4	420	11	–	2,5	70 <i>0.15</i>
714-450-VS	HOSE CR 45 DN3X450,VS	4	450	11	–	2,5	74 <i>0.16</i>
714-500-VS	HOSE CR 45 DN3X500,VS	4	500	11	–	2,5	84 <i>0.19</i>
714-580-VS	HOSE CR 45 DN3X580,VS	4	580	11	–	2,5	92 <i>0.20</i>
Low-pressure hoses with tube stud Ø4 mm with claw groove for quick connectors and metal braid							
714-180-M-VS	HOSE CR 45 DN3X180,VS, MET.BRAID.	4	180	11	12	2,5	56 <i>0.12</i>
714-260-M-VS	HOSE CR 45 DN3X260,VS, MET.BRAID.	4	260	11	12	2,5	69 <i>0.15</i>
714-300-M-VS	HOSE CR 45 DN3X300,VS, MET.BRAID.	4	300	11	12	2,5	75 <i>0.17</i>
714-400-M-VS	HOSE CR 45 DN3X400,VS, MET.BRAID.	4	400	11	12	2,5	97 <i>0.21</i>
714-500-M-VS	HOSE CR 45 DN3X500,VS, MET.BRAID.	4	500	11	12	2,5	119 <i>0.26</i>
714-580-M-VS	HOSE CR 45 DN3X580,VS, MET.BRAID.	4	580	11	12	2,5	167 <i>0.37</i>
Low-pressure hoses with tube stud Ø6 mm with claw groove for quick connectors							
716-220-VS	HOSE CR 45 DN4,5X220,VS	6	220	13	–	3,6	64 <i>0.14</i>
716-300-VS	HOSE CR 45 DN4,5X300,VS	6	300	13	–	3,6	72 <i>0.16</i>
716-340-VS	HOSE CR 45 DN4,5X340,VS	6	340	13	–	3,6	79 <i>0.17</i>
716-380-VS	HOSE CR 45 DN4,5X380,VS	6	380	13	–	3,6	86 <i>0.19</i>
716-420-VS	HOSE CR 45 DN4,5X420,VS	6	420	13	–	3,6	90 <i>0.20</i>
716-500-VS	HOSE CR 45 DN4,5X500,VS	6	500	13	–	3,6	101 <i>0.22</i>
716-580-VS	HOSE CR 45 DN4,5X580,VS	6	580	13	–	3,6	128 <i>0.28</i>
Low-pressure hoses with tube stud Ø6 mm with claw groove for quick connectors and metal braid							
716-300-M-VS	HOSE CR 45 DN4,5X300,VS, MET.BRAID.	6	300	13	14	3,6	108 <i>0.24</i>
716-400-M-VS	HOSE CR 45 DN4,5X400,VS, MET.BRAID.	6	400	13	14	3,6	140 <i>0.31</i>
716-450-M-VS	HOSE CR 45 DN4,5X500,VS, MET.BRAID.	6	450	13	14	3,6	155 <i>0.34</i>
716-500-M-VS	HOSE CR 45 DN4,5X580,VS, MET.BRAID.	6	500	13	14	3,6	165 <i>0.36</i>
Low-pressure hoses with tube stud Ø8 mm with claw groove for quick connectors							
718-340-VS	HOSE CR 45 DN6,5X340,VS	8	340	15	–	4,4	117 <i>0.26</i>
718-450-VS	HOSE CR 45 DN6,5X450,VS	8	450	15	–	4,4	133 <i>0.29</i>
718-580-VS	HOSE CR 45 DN6,5X580,VS	8	580	15	–	4,4	141 <i>0.31</i>
Low-pressure hoses with tube stud Ø8 mm with claw groove for quick connectors and metal braid							
718-400-M-VS	HOSE CR 45 DN6,5X400,VS, MET.BRAID.	8	400	15	16	4,4	136 <i>0.30</i>
718-450-M-VS	HOSE CR 45 DN6,5X450,VS, MET.BRAID.	8	450	15	16	4,4	157 <i>0.35</i>
718-500-M-VS	HOSE CR 45 DN6,5X500,VS, MET.BRAID.	8	500	15	16	4,4	174 <i>0.38</i>

¹⁾ Material hose: mineral oil resistant CR rubber inside; 2 layers of braided rayon, outside rubber conditionally oil resistant, resistant to light cracks and ozone.
Material metal braid: galvanized steel wire; tube ends: galvanized steel tubing.

Low-pressure hoses for secondary lines max. 15 bar

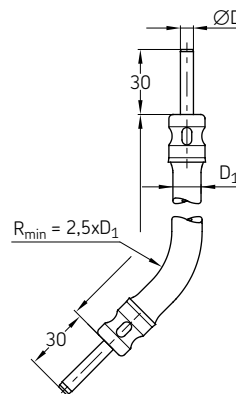

Order number	Designation ¹⁾	Tube	Length	Rubber	Weight	
		ØD		ØD ₁	g	lb
		mm	mm	mm		
734-180	HOSE CR 15 DN3X 180,STU 4	4	180	8,8	30	0,07
734-220	HOSE CR 15 DN3X 220,STU 4	4	220	8,8	33	0,07
734-260	HOSE CR 15 DN3X 260,STU 4	4	260	8,8	37	0,08
734-300	HOSE CR 15 DN3X 300,STU 4	4	300	8,8	40	0,09
734-380	HOSE CR 15 DN3X 380,STU 4	4	380	8,8	45	0,10
734-420	HOSE CR 15 DN3X 420,STU 4	4	420	8,8	47	0,10
734-450	HOSE CR 15 DN3X 450,STU 4	4	450	8,8	48	0,11
734-500	HOSE CR 15 DN3X 500,STU 4	4	500	8,8	58	0,13
734-580	HOSE CR 15 DN3X 580,STU 4	4	580	8,8	61	0,13

¹⁾ Material hose: mineral oil resistant CR rubber inside; 2 layers of braided rayon, outside rubber conditionally oil resistant, resistant to light cracks and ozone.
Material metal braid: galvanized steel wire; tube ends: galvanized steel tubing.

Low-pressure hoses for secondary lines max. 15 bar with tapered sleeve and socket union on both ends

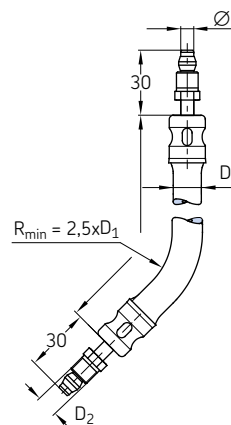

Order number	Designation ¹⁾	Tube	Length	Rubber	Thread	Weight	
		ØD		ØD ₁	ØD ₂	g	lb
		mm	mm	mm	mm		
734-180-K	HOSE CR 15 DN3X 180,M8X1	4	180	8,8	M8x1	36	0,08
734-220-K	HOSE CR 15 DN3X 220,M8X1	4	220	8,8	M8x1	41	0,09
734-260-K	HOSE CR 15 DN3X 260,M8X1	4	260	8,8	M8x1	44	0,10
734-300-K	HOSE CR 15 DN3X 300,M8X1	4	300	8,8	M8x1	46	0,10
734-380-K	HOSE CR 15 DN3X 380,M8X1	4	380	8,8	M8x1	51	0,11
734-420-K	HOSE CR 15 DN3X 420,M8X1	4	420	8,8	M8x1	53	0,12
734-450-K	HOSE CR 15 DN3X 450,M8X1	4	450	8,8	M8x1	56	0,12
734-500-K	HOSE CR 15 DN3X 500,M8X1	4	500	8,8	M8x1	60	0,13
734-580-K	HOSE CR 15 DN3X 580,M8X1	4	580	8,8	M8x1	68	0,15

¹⁾ Material hose: mineral oil resistant CR rubber inside; 2 layers of braided rayon, outside rubber conditionally oil resistant, resistant to light cracks and ozone.
Material metal braid: galvanized steel wire; tube ends: galvanized steel tubing.

Tubes and hoses

Low-pressure hoses
for secondary lines max. 15 bar
with claw groove for quick connectors
on both ends

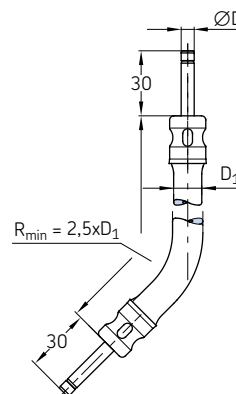

Order number	Designation ¹⁾	Tube	Length	Rubber	Weight	
		ØD		ØD ₁	g	lb
		mm	mm	mm		
734-180-VS	HOSE CR 15 DN3X 180,VS	4	180	8,8	30	0.07
734-220-VS	HOSE CR 15 DN3X 220,VS	4	220	8,8	33	0.07
734-260-VS	HOSE CR 15 DN3X 260,VS	4	260	8,8	37	0.08
734-300-VS	HOSE CR 15 DN3X 300,VS	4	300	8,8	40	0.09
734-380-VS	HOSE CR 15 DN3X 380,VS	4	380	8,8	45	0.10
734-420-VS	HOSE CR 15 DN3X 420,VS	4	420	8,8	47	0.10
734-450-VS	HOSE CR 15 DN3X 450,VS	4	450	8,8	48	0.11
734-500-VS	HOSE CR 15 DN3X 500,VS	4	500	8,8	58	0.13
734-580-VS	HOSE CR 15 DN3X 580,VS	4	580	8,8	61	0.13

¹⁾ Material hose: mineral oil resistant CR rubber inside; 2 layers of braided rayon, outside rubber conditionally oil resistant, resistant to light cracks and ozone.
Material metal braid: galvanized steel wire; tube ends: galvanized steel tubing.

Tubes and hoses

Low-pressure hoses suitable for self-installation max. 45 bar

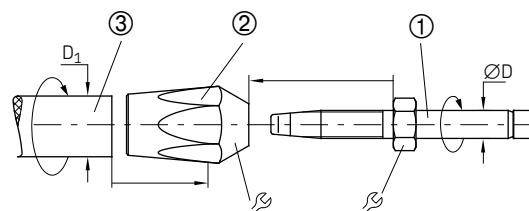

Order number	Designation	Tube			Material	Max. increase in volume ~ 40 bar	Weight	
		ØD	D ₁	∅			cm ³ /m	g
		mm	mm	mm				
① Hose coupling								
406-704-001	HOSE COUPLING, STRAIGHT, D 4, BEL	-	-	8	Steel, galvanized	1	7	0.01
406-706-001	HOSE COUPLING, STRAIGHT, D 6, BEL	-	-	10	Steel, galvanized	1,4	11	0.02
406-708-001	HOSE COUPLING, STRAIGHT, D 8, BEL	-	-	13	Steel, galvanized	1,4	21	0.04
406-704-001-VS	1) HOSE COUPLING, STRAIGHT, D 4, VS	-	-	8	Steel, galvanized	1	7	0.01
406-706-001-VS	1) HOSE COUPLING, STRAIGHT, D 6, VS	-	-	10	Steel, galvanized	1,4	11	0.02
406-708-001-VS	1) HOSE COUPLING, STRAIGHT, D 8, VS	-	-	13	Steel, galvanized	1,4	21	0.04
② Threaded sleeve								
406-804-001	THREADED SLEEVE F.HOSE STUD D 4	-	-	14	Brass	1	20	0.04
406-806-001	THREADED SLEEVE F.HOSE STUD D 6	-	-	17	Brass	1,4	31	0.07
406-808-001	THREADED SLEEVE F.HOSE STUD D 8	-	-	19	Brass	1,4	36	0.08
③ Hose								
WVN701-4	2) HOSE CR 45 DN 3	4	11	-	Perbunan, braided rayon	1	117	0.26
WVN701-6	2) HOSE CR 45 D 4,5	6	13	-	Perbunan, braided rayon	1,4	153	0.34
WVN701-8	2) HOSE CR 45 DN 6,5	8	15	-	Perbunan, braided rayon	1,4	190	0.42

1) VS = version with claw groove on tube ends for quick connectors

2) Please quote length when ordering. Max. length available 20 m

3) Perbunan, resistant to mineral oils, with two layers of braided rayon

Permissible operating pressure: -40 to +100 °C / -40 to +212 °F

Installation notes

- Apply thin film of oil to inner hose end, inner threaded sleeve and outer hose coupling end.
- Screw threaded sleeve onto hose end up to the stop.
- Clamp threaded sleeve in vise and screw in hose coupling turning it to the left up to the stop.



Important note

To avoid damages screw all parts only up to the stop. Do not tighten!

Tubes and hoses

High-pressure hoses with pipe stud for high volume

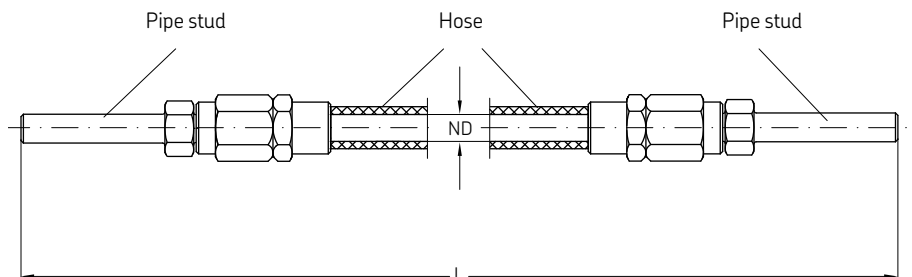

Order number	Designation	Nominal diameter		Material hose	Fitting	Operating pressure max.		Weight	
		ND	L			bar	psi	g	lb
		mm	mm						
225-12486-5	HOSE HY200 NW 6X840, STU10	6	840	Perbunan, braided steel ¹⁾	Pipe stud 10	200	2 900	0,36	0.79
225-12324-3	HOSE HY560 NW 8X540, STU10	8	540	Perbunan, braided steel ¹⁾	Pipe stud 10	560	8 120	0,31	0.68
225-12324-5	HOSE HY560 NW 8X740, STU10	8	740	Perbunan, braided steel ¹⁾	Pipe stud 10	560	8 120	0,37	0.82
225-12324-8	HOSE HY560 NW 8X1040, STU10	8	1 040	Perbunan, braided steel ¹⁾	Pipe stud 10	560	8 120	0,44	0.97
225-12325-1	HOSE HY560 NW 8X1540, STU10	8	1 540	Perbunan, braided steel ¹⁾	Pipe stud 10	560	8 120	0,7	1.54
225-12325-2	HOSE HY560 NW 8X2040, STU10	8	2 040	Perbunan, braided steel ¹⁾	Pipe stud 10	560	8 120	0,91	2.01
225-12576-1	HOSE ND 16 NW13X840, STU15	13	840	Perbunan, braided steel ¹⁾	Pipe stud 15	16	230	0,55	1.21
225-13039-2	HOSE ND 16 NW13X1040, STU15	13	1 040	Perbunan, braided steel ¹⁾	Pipe stud 15	16	230	0,6	1.32
225-13039-8	HOSE ND 16 NW13X1240, STU15	13	1 240	Perbunan, braided steel ¹⁾	Pipe stud 15	16	230	0,95	2.09
225-12576-3	HOSE ND 16 NW13X1540, STU15	13	1 540	Perbunan, braided steel ¹⁾	Pipe stud 15	16	230	0,86	1.9
225-12576-2	HOSE ND 16 NW13X2040, STU15	13	2 040	Perbunan, braided steel ¹⁾	Pipe stud 15	16	230	1,03	2.27
225-12414-6	HOSE HY400 DN16X1200 DKOS /DKOS	16	1 200	Perbunan, braided steel ¹⁾	DKOS/DKOS	400	5 800	1,8	3.97
225-12414-7	HOSE HY400 DN16X1500 DKOS /DKOS	16	1 500	Perbunan, braided steel ¹⁾	DKOS/DKOS	400	5 800	2,2	4.85
225-12414-8	HOSE HY400 DN16X2000 DKOS /DKOS	16	2 000	Perbunan, braided steel ¹⁾	DKOS/DKOS	400	5 800	3	6.62

¹⁾ Perbunan, resistant to mineral oils, with two layers of braided steel

Tubes and hoses

High-pressure hoses \varnothing 8.6 mm (ND4) pipe stud 6 mm

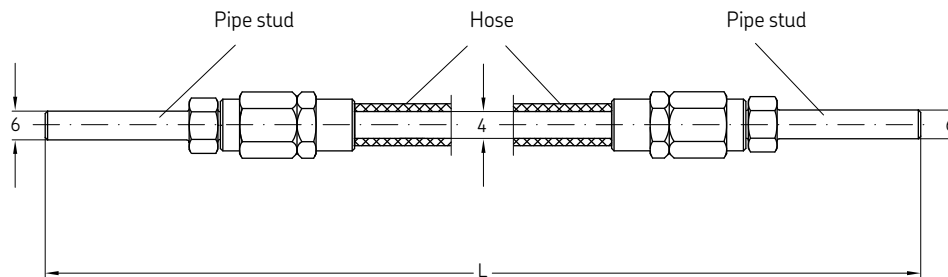

Order number	Designation	L	Material hose	Operating pressure max.		Weight	
				bar	psi	g	lb
		mm					
666-34221-9	HDS 1 HOSE NW 4X 200	200	Perbunan, braided steel ¹⁾	350	5 080	41	0.09
666-34220-1	HDS 1 HOSE NW 4X 300	300	Perbunan, braided steel ¹⁾	350	5 080	60	0.13
666-36087-2	HDS 1 HOSE NW 4X 400	400	Perbunan, braided steel ¹⁾	350	5 080	70	0.15
666-85311-1	HDS 1 HOSE NW 4X 510	510	Perbunan, braided steel ¹⁾	350	5 080	79	0.17
666-34639-5	HDS 1 HOSE NW 4X 600	600	Perbunan, braided steel ¹⁾	350	5 080	80	0.18
666-36059-8	HDS 1 HOSE NW 4X 700	700	Perbunan, braided steel ¹⁾	350	5 080	86	0.19
666-36087-1	HDS 1 HOSE NW 4X 800	800	Perbunan, braided steel ¹⁾	350	5 080	93	0.21
666-36831-9	HDS 1 HOSE NW 4X 900	900	Perbunan, braided steel ¹⁾	350	5 080	96	0.21
666-36087-3	HDS 1 HOSE NW 4X 1000	1 000	Perbunan, braided steel ¹⁾	350	5 080	101	0.22
666-34221-5	HDS 1 HOSE NW 4X 1250	1 250	Perbunan, braided steel ¹⁾	350	5 080	122	0.27
666-36081-7	HDS 1 HOSE NW 4X 1500	1 500	Perbunan, braided steel ¹⁾	350	5 080	136	0.30
666-34578-9	HDS 1 HOSE NW 4X 1750	1 750	Perbunan, braided steel ¹⁾	350	5 080	140	0.31
666-36087-7	HDS 1 HOSE NW 4X 2000	2 000	Perbunan, braided steel ¹⁾	350	5 080	146	0.32
666-36081-8	HDS 1 HOSE NW 4X 2500	2 500	Perbunan, braided steel ¹⁾	350	5 080	181	0.40
666-36081-9	HDS 1 HOSE NW 4X 3000	3 000	Perbunan, braided steel ¹⁾	350	5 080	207	0.46
666-34028-2	HDS 1 HOSE NW 4X 3500	3 500	Perbunan, braided steel ¹⁾	350	5 080	230	0.51
666-36087-8	HDS 1 HOSE NW 4X 4000	4 000	Perbunan, braided steel ¹⁾	350	5 080	260	0.57
666-34028-3	HDS 1 HOSE NW 4X 4500	4 500	Perbunan, braided steel ¹⁾	350	5 080	286	0.63
666-34578-5	HDS 1 HOSE NW 4X 5000	5 000	Perbunan, braided steel ¹⁾	350	5 080	301	0.66

¹⁾ Perbunan, resistant to mineral oils, with two layers of braided steel

Tubes and hoses

High-pressure hoses for self-installation

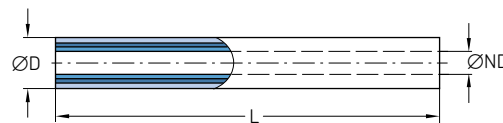

Order number ¹⁾	Designation	Tube	Nominal	Length	Material hose	Burst pressure		Weight	
		ØD	diameter ND			bar	psi	g	lb
		mm	mm	m					
111-35114-1	HOSE PL300 NW4,0 HIGHFLEXIBLE	8,6	4	1	Polyamide, polyurethane ²⁾	840	12 183	48	0.106
1110-00000002	HP HOSE 8,6/4,1-PA6/PUR-BK COIL50M	8,6	4	50	Polyamide, polyurethane ²⁾	840	12 183	2400	5.291
111-35301-4	HOSE, PL400 NW6,0 HIGHFLEXIBLE	11,2	6	1	Polyamide, polyurethane ²⁾	840	12 183	70	0.154
1110-00000001	HP HOSE 11,3/6,4-PA6/PUR-BK COIL50M	11,2	6	50	Polyamide, polyurethane ²⁾	840	12 183	3500	7.716
WVN711-10	HOSE, 3TE,NW8,0 HIGHFLEXIBLE	16,5	8	1	Polyamide, polyurethane ²⁾	840	12 183	198	0.432

¹⁾ Hoses can be delivered prefilled with lubricant on request.

²⁾ Inner hose = polyamide, soft; pressure reinforcement = polyamide high strength; sheathing = polyurethane

Installation notes

- Apply thin film of oil to inner hose end, inner threaded sleeve and outer hose coupling end.
- Screw threaded sleeve onto hose end up to the stop.
- Clamp threaded sleeve in vise and screw in hose coupling turning it to the left up to the stop.



Important note

To avoid damage, screw all parts only up to the stop. Do not tighten!

Scheme - High-pressure hose self-mounting components

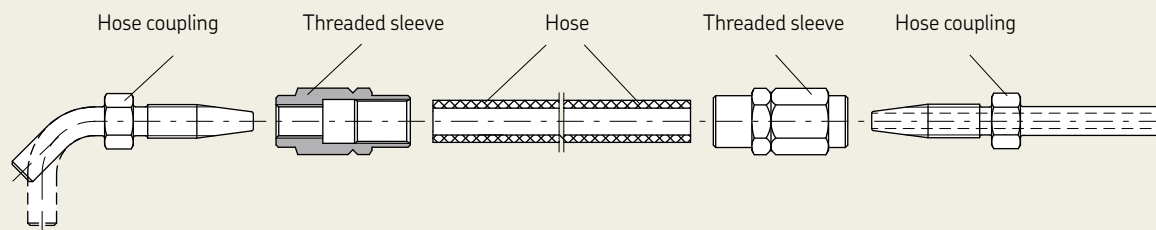

Threaded joints for high-pressure hoses

Threaded sleeve

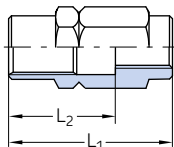

Hose coupling straight

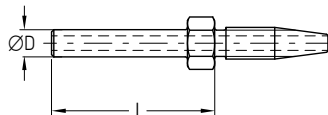

Hose coupling bent

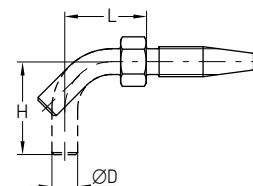

Order number	Designation	Tube ØD DN		L	H	Material	Weight	
		mm	mm				g	lb
853-540-010	THREADED SLEEVE F.HOSE STUD D 6	6	4	28	17	Zinc-nickel, Cr-6-free	12	0.26
432-23676-1	THREADED SLEEVE F.HOSE STUD 6 VA	6	4	28	17	Stainless steel	12	0.26
Quick connector								
853-380-006-VS	HOSE COUPLING, STRAIGHT, D4, VS	4	2	39	–	Zinc-nickel, Cr-6-free	12	0.26
853-380-002-VS	HOSE COUPLING, STRAIGHT, D 6, VS	6	4	39	–	Zinc-nickel, Cr-6-free	12	0.26
853-390-002-VS	HOSE COUPLING STRAIGHT, D 6, VS	6	4	75	–	Zinc-nickel, Cr-6-free	18	0.03
853-390-006-VS	HOSE COUPLING 10°, D 6, VS	6	4	70	10	Zinc-nickel, Cr-6-free	18	0.03
853-390-005-VS	HOSE COUPLING 30°, D 6, VS	6	4	70	17	Zinc-nickel, Cr-6-free	19	0.04
853-380-004-VS	HOSE COUPLING 45°, D 6, VS	6	4	40	23	Zinc-nickel, Cr-6-free	14	0.03
853-380-007-VS	HOSE COUPLING, 45°, D 6, VS	6	4	65	18	Zinc-nickel, Cr-6-free	19	0.04
853-390-004-VS	HOSE COUPLING 45°, D 6, VS	6	4	65	24	Zinc-nickel, Cr-6-free	19	0.04
853-380-003-VS	HOSE COUPLING 90°, D 6, VS	6	4	19	35	Zinc-nickel, Cr-6-free	14	0.03
853-390-003-VS	HOSE COUPLING 90°, D 6, VS	6	4	30	50	Zinc-nickel, Cr-6-free	19	0.04
855-380-002-VS	HOSE COUPLING VA, STRAIGHT, D 6, VS	6	4	39	–	Stainless steel	12	0.26
855-380-003-VS	HOSE COUPLING VA 90°, D 6, VS	6	4	19	35	Stainless steel	13	0.03
Screwed version								
853-370-002	HOSE COUPLING, STRAIGHT, D 6, BEL	6	4	26	–	Zinc-nickel, Cr-6-free	10	0.02
853-380-002	HOSE COUPLING, STRAIGHT, D 6, BEL	6	4	36	–	Zinc-nickel, Cr-6-free	12	0.02
853-390-002	HOSE COUPLING, STRAIGHT, D 6, BEL	6	4	75	–	Zinc-nickel, Cr-6-free	20	0.04
853-380-004	HOSE COUPLING 45°, D 6, BEL	6	4	23	11	Zinc-nickel, Cr-6-free	20	0.04
853-380-003	HOSE COUPLING 90°, D 6, BEL	6	4	19	21	Zinc-nickel, Cr-6-free	10	0.02
853-390-003	HOSE COUPLING 90°, D 6, BEL	6	4	30	50	Zinc-nickel, Cr-6-free	20	0.04
406-808-005	THREADED SLEEVE F.HOSE STUD D 8	8	6	35	23	Zinc-nickel, Cr-6-free	34	0.07
855-380-002	HOSE COUPLING VA, STRAIGHT, D 6, BEL	6	4	36	–	Stainless steel	12	0.02
855-380-003	HOSE COUPLING VA 90°, D 6, BEL	6	4	19	21	Stainless steel	13	0.02
406-808-005-S3	THREADED SLEEVE F.HOSE STUD D 8 VA	8	6	35	23	Stainless steel	34	0.07
Quick connector								
406-708-005-VS	HOSE COUPLING, STRAIGHT, D 8, VS	8	6	39	–	Zinc-nickel, Cr-6-free	21	0.05
Screwed version								
406-708-005	HOSE COUPLING, STRAIGHT, D 8, BEL	8	6	26	–	Zinc-nickel, Cr-6-free	19	0.04
406-708-006	HOSE COUPLING, STRAIGHT, D 8, BEL	8	6	32	–	Zinc-nickel, Cr-6-free	20	0.04
406-708-007	HOSE COUPLING, STRAIGHT, D 8, BEL	8	6	53	–	Zinc-nickel, Cr-6-free	24	0.05
406-708-009	HOSE COUPLING 45°, D 8, BEL	8	6	43	26	Zinc-nickel, Cr-6-free	20	0.04
406-708-008	HOSE COUPLING 90°, D 8, BEL	8	6	25	34	Zinc-nickel, Cr-6-free	20	0.04
406-810-002	THREADED SLEEVE F.HOSE STUD D 10	10	8	41	32	Zinc-nickel, Cr-6-free	47	0.10
406-708-005-S3	HOSE COUPLING VA, STRAIGHT, D 8, BEL	8	6	22	–	Stainless steel	20	0.04
Screwed version								
406-710-002	HOSE COUPLING, STRAIGHT, D 10, BEL	10	8	35	–	Zinc-nickel, Cr-6-free	32	0.07

Fixing material



Description

The following chapter “fixing material” includes the screws and bolts for fixing the individual components of lubrication systems, as well as cable straps, mounting bases and a large selection of pipe clamps for fixing the pipes.

Clamps for pipes with a diameter of 8 mm and 10 mm are available in two versions: One according to DIN 72573 and another reinforced design version with a thicker and wider metal sheet than DIN 72573.

For use in corrosive areas, various mounting parts are also available in stainless steel (material 1.4571).

Features and benefits

- Wide product range with many different dimensions
- Recommended and reliable fixing material for lubrication system components such as pipes and tubes
- Suitable for all types of automatic lubrication systems

Applications

- Metal forming machines
- On- and off-road vehicles
- Construction and mining
- Agriculture machinery
- Packaging machines
- General industry
- Etc.

Fixing material

Fixing clips

602-001 – 612-001, 226-xxxx-1

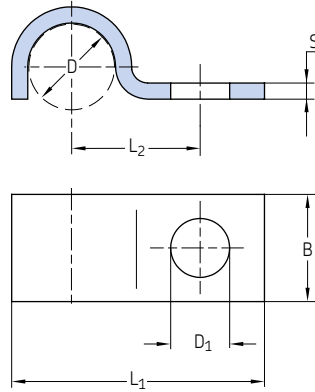

608-003

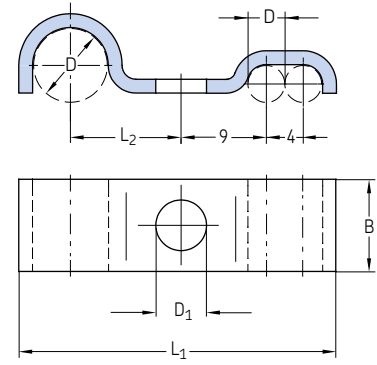

Order number	Designation	Tube ØD	B	D ₁	L ₁	L ₂	S	Material	Weight (100 pcs)	
									g	lb
Steel										
602-001	TUBE CLAMP ST-Z D 2.5 (1X)	2,5 mm	10	3,5	11,25	5	1,5	Steel	200	0.44
604-001	TUBE CLAMP ST-Z D 4 (1X)	4 mm	10	5,5	18,5	9	1,5	Steel	200	0.44
606-010	TUBE CLAMP ST-Z D 6 (1X)	6 mm	10	5,5	20,5	10	1,5	Steel	300	0.66
608-001	TUBE CLAMP ST-Z D 8 (1X)	8 mm	10	5,5	23,5	12	1,5	Steel	300	0.66
610-001	TUBE CLAMP ST-Z D10 (1X)	10 mm or 1/8	10	5,5	25,5	13	1,5	Steel	400	0.88
612-001	TUBE CLAMP ST-Z D12 (1X)	12 mm	20	6,8	35	18	2	Steel	500	1.1
608-003	TUBE CLAMP ST-Z D8 (1X) D4 (2X)	8/4	10	5,5	34	12	1,5	Steel	100	0.22
Zinc-plated steel										
226-12337-1	TUBE CLAMP ST-Z D 8(1X)ZG	8 mm	15	7	28	15,5	2	Zinc-plated steel	700	1.54
226-12338-1	TUBE CLAMP ST-Z D10(1X)ZG	10 mm	15	7	30	15	2	Zinc-plated steel	800	1.76
Stainless steel										
226-12335-7	TUBE CLAMP 1.4571 D 6 (1X)	6 mm	10	4,8	20,5	10	1	Stainless steel	200	0.44
226-13717-1	TUBE CLAMP 1.4571 D 8(1X)ZG	8 mm	15	7	28	15,5	2	Stainless steel	700	1.54
226-13673-1	TUBE CLAMP 1.4571 D10(1X)ZG	10 mm	15	7	30	15	2	Stainless steel	800	1.76

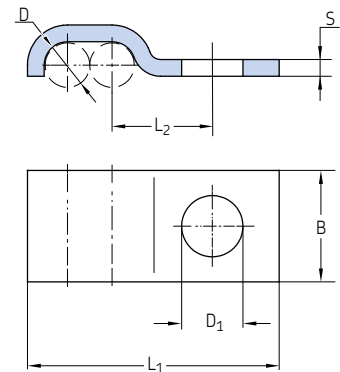

Order number	Designation	Tube ØD for tube		B	D ₁	L ₁	L ₂	S	Material	Weight (100 pcs)	
		mm	mm							g	lb
602-002	TUBE CLAMP ST-Z D 2.5 (2X)	2,5	2	10	3,5	13,8	5	1,5	Mild steel	200	0.44
604-002	TUBE CLAMP ST-Z D 4 (2X)	4	2	10	5,5	22,6	9	1,5	Mild steel	200	0.44
604-003	TUBE CLAMP ST-Z D 4 (3X)	4	3	10	5,5	26,6	9	1,5	Mild steel	300	0.66

Fixing material

Fixing clips

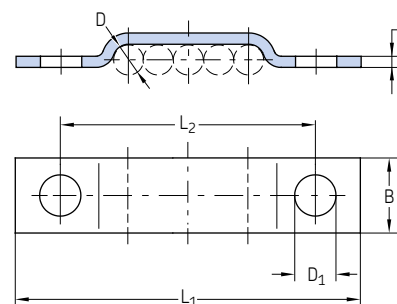

Order number	Designation	Tube		B	D ₁	L ₁	L ₂	S	Material	Weight (100 pcs)	
		∅D	for tube							g	lb
mm											
Mild steel											
604-014	TUBE CLAMP ST-Z D 4 (4X)	4	4	10	5,5	42	30	1,5	Mild steel	400	0.88
604-015	TUBE CLAMP ST-Z D 4 (5X)	4	5	10	5,5	46	34	1,5	Mild steel	400	0.88
604-016	TUBE CLAMP ST-Z D 4 (6X)	4	6	10	5,5	50	38	1,5	Mild steel	500	1.1
604-018	TUBE CLAMP ST-Z D 4 (8X)	4	8	10	5,5	58	46	1,5	Mild steel	600	1.32
DIN 72573-2x6-ST	TUBE CLAMP ST-Z D 6 (2X)	6	2	10	4,8	39	27	1	Mild steel	300	0.66
DIN 72573-3x6-ST	TUBE CLAMP ST-Z D 6 (3X)	6	3	10	4,8	45	33	1	Mild steel	400	0.88
DIN 72573-4x6-ST	TUBE CLAMP ST-Z D 6 (4X)	6	4	10	4,8	51	39	1	Mild steel	400	0.88
DIN 72573-5x6-ST	TUBE CLAMP ST-Z D 6 (5X)	6	5	10	4,8	57	45	1	Mild steel	400	0.88
DIN 72573-6x6-ST	TUBE CLAMP ST-Z D 6 (6X)	6	6	10	4,8	64	52	1	Mild steel	600	1.32
DIN 72573-2x8-ST	TUBE CLAMP ST-Z D 8 (2X)	8	2	10	4,8	43	31	1	Mild steel	400	0.88
DIN 72573-3x8-ST	TUBE CLAMP ST-Z D 8 (3X)	8	3	10	4,8	51	39	1	Mild steel	400	0.88
DIN 72573-4x8-ST	TUBE CLAMP ST-Z D 8 (4X)	8	4	10	4,8	59	47	1	Mild steel	500	1.1
DIN 72573-5x8-ST	TUBE CLAMP ST-Z D 8 (5X)	8	5	10	4,8	68	56	1	Mild steel	600	1.32
DIN 72573-6x8-ST	TUBE CLAMP ST-Z D 8 (6X)	8	6	10	4,8	76	64	1	Mild steel	700	1.54
DIN 72573-2x10-ST	TUBE CLAMP ST-Z D10 (2X)	10	2	10	4,8	45	33	1	Mild steel	400	0.88
DIN 72573-3x10-ST	TUBE CLAMP ST-Z D10 (3X)	10	3	10	4,8	55	43	1	Mild steel	500	1.1
DIN 72573-4x10-ST	TUBE CLAMP ST-Z D10 (4X)	10	4	10	4,8	67	55	1	Mild steel	600	1.32
DIN 72573-5x10-ST	TUBE CLAMP ST-Z D10 (5X)	10	5	10	4,8	77	65	1	Mild steel	800	1.76
Zinc-plated steel											
226-12337-2	TUBE CLAMP ST-Z D 8(2X)ZG	8	2	15	7	61,2	39	2	Zinc-plated steel	1 300	2.87
226-12337-3	TUBE CLAMP ST-Z D 8(3X)ZG	8	3	15	7	69,2	47	2	Zinc-plated steel	1 500	3.31
226-12337-4	TUBE CLAMP ST-Z D 8(4X)ZG	8	4	15	7	77,2	55	2	Zinc-plated steel	1 700	3.75
226-12337-5	TUBE CLAMP ST-Z D 8(5X)ZG	8	5	15	7	85,2	63	2	Zinc-plated steel	1 800	3.97
226-12337-6	TUBE CLAMP ST-Z D 8(6X)ZG	8	6	15	7	93,2	71	2	Zinc-plated steel	2 000	4.41
226-12338-2	TUBE CLAMP ST-Z D10(2X)ZG	10	2	15	7	65,3	40	2	Zinc-plated steel	1 300	2.87
226-12338-3	TUBE CLAMP ST-Z D10(3X)ZG	10	3	15	7	75,3	50	2	Zinc-plated steel	1 600	3.53
226-12338-4	TUBE CLAMP ST-Z D10(4X)ZG	10	4	15	7	85,3	60	2	Zinc-plated steel	1 800	3.97
226-12338-5	TUBE CLAMP ST-Z D10(5X)ZG	10	5	15	7	95,3	70	2	Zinc-plated steel	2 000	4.41
226-12338-6	TUBE CLAMP ST-Z D10(6X)ZG	10	6	15	7	105,3	80	2	Zinc-plated steel	2 200	4.85
Stainless steel											
DIN72573-1x6-NIRO	TUBE CLAMP 1.4571 D 6 (1X)	6	1	10	4,8	32	20	1	Stainless steel	300	0.66
DIN72573-2x6-NIRO	TUBE CLAMP 1.4571 D 6 (2X)	6	2	10	4,8	38	26	1	Stainless steel	300	0.66
DIN72573-3x6-NIRO	TUBE CLAMP 1.4571 D 6 (3X)	6	3	10	4,8	45	33	1	Stainless steel	300	0.66
DIN72573-4x6-NIRO	TUBE CLAMP 1.4571 D 6 (4X)	6	4	10	4,8	51	39	1	Stainless steel	400	0.88
DIN72573-5x6-NIRO	TUBE CLAMP 1.4571 D 6 (5X)	6	5	10	4,8	57	45	1	Stainless steel	400	0.88
DIN72573-6x6-NIRO	TUBE CLAMP 1.4571 D 6 (6X)	6	6	10	4,8	64	52	1	Stainless steel	500	1.1
226-13717-2	TUBE CLAMP 1.4571 D 8(2X)ZG	8	2	15	7	61,2	39	2	Stainless steel	1 200	2.65
226-13717-3	TUBE CLAMP 1.4571 D 8(3X)ZG	8	3	15	7	69,2	47	2	Stainless steel	1 400	3.09
226-13717-4	TUBE CLAMP 1.4571 D 8(4X)ZG	8	4	15	7	77,2	55	2	Stainless steel	1 600	3.53
226-13718-1	TUBE CLAMP 1.4571 D10(2X)ZG	10	2	15	7	65,3	40	2	Stainless steel	1 300	2.87
223-13673-4	TUBE CLAMP 1.4571 D10(3X)ZG	10	3	15	7	75,3	50	2	Stainless steel	1 600	3.53
226-13673-5	TUBE CLAMP 1.4571 D10(4X)ZG	10	4	15	7	85,3	60	2	Stainless steel	1 700	3.75

Fixing material

Fixing clips

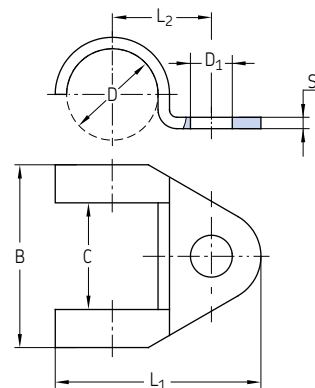

Order number	Designation	Tube ØD		B	C	D ₁	L ₁	L ₂	S	Material	Weight (100 pcs)	
		mm	in								g	lb
604-004	TUBE CLAMP ST-Z D12 (1X)	12	-	24	14	5,5	27	13	1,5	Steel	500	1.1
606-014	TUBE CLAMP ST-Z D14 (1X)	14	1/4	30	15	6,3	32,5	16	2	Steel	1 200	2.65
608-004	TUBE CLAMP ST-Z D18 (1X)	18	3/8	36	20	7	40	21	2	Steel	1 200	2.65
610-004	TUBE CLAMP ST-Z D20 (1X)	20	1/2	36	20	7	40	21	2	Steel	1 200	2.65

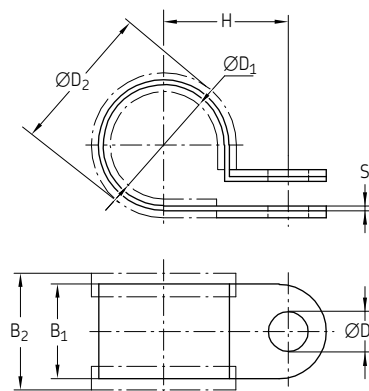

Order number	Designation	ØD ₁	ØD ₂	ØD ₃	B ₁	B ₂	H	S	Material	Weight (100 pcs)	
										mm	mm
941-206-104	TUBE CLAMP ST-RUB. D 6 F.FAST.SCREW M5	6	11,8	5,2	12	15	11	0,5	Steel, galvanized	400	0.88
941-206-108	TUBE CLAMP ST-RUB. D 6 F.FAST.SCREW M6	6	11,8	6,4	15	18,5	4,2	0,6	Steel, galvanized	700	1.54
941-208-104	TUBE CLAMP ST-RUB. D 8 F.FAST.SCREW M6	8	15,4	6,4	15	18,5	15,2	0,6	Steel, galvanized	800	1.76
941-209-104	TUBE CLAMP ST-RUB. D 9 F.FAST.SCREW M5	9	5	5,2	12	5	12,5	0,5	Steel, galvanized	500	1.1
941-209-105	TUBE CLAMP ST-RUB. D 9 F.FAST.SCREW M6	9	15	6,4	15	18,5	15,7	0,6	Steel, galvanized	900	1.98
941-210-104	TUBE CLAMP ST-RUB. D10 F.FAST.SCREW M6	10	17,4	6,4	15	18,5	16,2	0,6	Steel, galvanized	900	1.98
941-212-104	TUBE CLAMP ST-RUB. D12 F.FAST.SCREW M6	12	19,4	6,4	15	18,5	17,2	0,6	Steel, galvanized	1 000	2.21
941-213-104	TUBE CLAMP ST-RUB. D13 F.FAST.SCREW M6	13	20,4	6,4	15	18,5	7,7	0,6	Steel, galvanized	1 100	2.43
941-215-104	TUBE CLAMP ST-RUB. D15 F.FAST.SCREW M6	15	22,4	6,4	5	18,5	18,7	0,8	Steel, galvanized	2 000	4.41
941-217-104	TUBE CLAMP ST-RUB. D17 F.FAST.SCREW M5	17	23	5,2	12	15	16,5	0,5	Steel, galvanized	800	1.76
941-217-105	TUBE CLAMP ST-RUB. D17 F.FAST.SCREW M6	17	23	6,4	15	8,5	19,7	0,8	Steel, galvanized	1 500	3.31
941-218-101	TUBE CLAMP ST-RUB. D18 F.FAST.SCREW M6	18	24	6,4	15	8,5	20,2	0,6	Steel, galvanized	1 400	3.09
941-220-104	TUBE CLAMP ST-RUB. D20 F.FAST.SCREW M6	20	27,6	6,4	15	8,5	21,2	0,8	Steel, galvanized	1 500	3.31
941-222-100	TUBE CLAMP ST-RUB. D22 F.FAST.SCREW M6	22	28	6,4	15	18,5	22,2	0,8	Steel, galvanized	1 700	3.75
941-225-104	TUBE CLAMP ST-RUB. D25 F.FAST.SCREW M6	25	31	6,4	15	18,5	23,7	0,8	Steel, galvanized	2 000	4.41

Fixing material

Pipe brackets acc. to DIN 3015

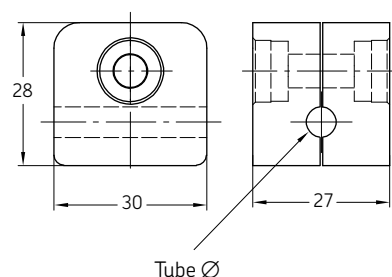

Order number	Designation	Tube Ø	Material	Weight	
				g	lb
		mm			
941-606-000	TUBE CLAMP 106 PP	6	Polypropylene	10	0.02
941-608-000	TUBE CLAMP 108 PP	8	Polypropylene	10	0.02
941-610-000	TUBE CLAMP 110 PP	10	Polypropylene	5	0.01
Tube clamp PP with weld plate, standard series					
226-12343-5	TUBE CLAMP SP 110 PP -LI	10	Polypropylene	40	0.09
226-12343-1	TUBE CLAMP SP 320 PP -LI	20	Polypropylene	77	0.17
226-13097-3	TUBE CLAMP SP 320 /20 PP -GD -AS	2 x 20	Polypropylene	173	0.38
226-12343-2	TUBE CLAMP SP 430 PP -LI	30	Polypropylene	80	0.18
Tube clamp PP with weld plate and cover plate, heavy series					
226-13058-3	TUBE CLAMP SPAL4020 PP -DPAL-AS	20	Polypropylene	394	0.87
226-13058-5	TUBE CLAMP SPAL5030 PP -DPAL-AS	30	Polypropylene	480	1.06

Cable straps

898-610-000, 898-710-000, 898-710-001

898-510-000

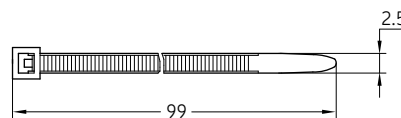
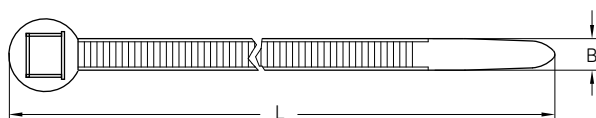

Order number	Designation	L	B	Material	Weight (100 pcs)	
					mm	mm
898-610-000	CABLE STRAP SW 204LGX4.7	197	4,9	Polyamide	100	0.22
898-710-000	CABLE STRAP SW 302LGX4.8	302	4,9	Polyamide	200	0.44
898-710-001	CABLE STRAP SW 360LGX7.5	360	7,5	Polyamide	500	1.10
For automatic pincers						
898-510-000	CABLE STRAP SW 100LGX2.5	99	2,5	Polyamide	100	0.22

Fixing material

Mounting base

Order number	Designation	Material	Weight (100 pcs)	
			g	lb
179-990-186	MOUNTING PLATE 25,4X25,4	ABS	100	0.22

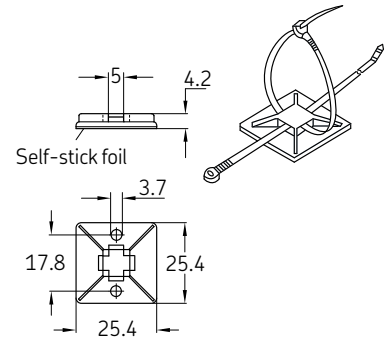

Fixing bolts

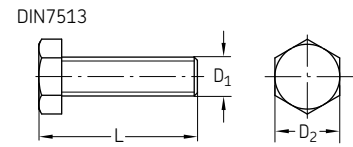
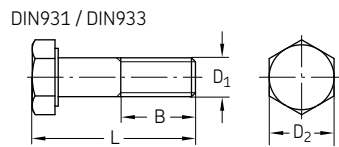
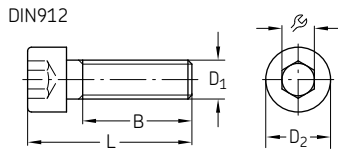

Order number	Designation	D ₁	L	D ₂	B	⌀	Material	Weight	
								g	lb
201-12015-5	SCREW,SOCK,HEX. 8.8 M4X 20CF	M4	20	7	14	3	Steel, galvanized	3	0.007
201-12019-9	SCREW,SOCK,HEX. 8.8 M6X 16CF	M6	16	10	18	5	Steel, galvanized	6	0.013
201-12018-7	SCREW,SOCK,HEX. 8.8 M6X 25CF	M6	25	10	18	5	Steel, galvanized	7	0.015
201-12019-6	SCREW,SOCK,HEX. 8.8 M6X 60CF	M6	60	10	18	5	Steel, galvanized	14	0.031
201-12021-3	SCREW,SOCK,HEX. 8.8 M8X 16CF	M8	16	13	12	6	Steel, galvanized	20	0.044
DIN931-M6x30-8.8	SCREW,HEX. 8.8 M 6X 30CF	M6	30	10	18	10	Steel, galvanized	8	0.018
DIN933-M4x10-8.8	SCREW,HEX. 8.8 M 4X 10CF	M4	10	7	5	-	Steel, galvanized	2	0.004
200-13092-1	SCREW,HEX. 8.8 M 5X 12CF	M5	12	8	6	-	Steel, galvanized	3	0.007
200-13017-9	SCREW,HEX. 8.8 M 5X 16CF	M5	16	8	11	-	Steel, galvanized	3	0.007
200-13017-5	SCREW,HEX. 8.8 M 5X 45CF	M5	45	8	40	-	Steel, galvanized	7	0.015
200-13022-4	SCREW,HEX. 8.8 M 6X 16CF	M6	16	10	9	-	Steel, galvanized	5	0.011
200-13022-7	SCREW,HEX. 8.8 M 6X 20CF	M6	20	10	13	-	Steel, galvanized	6	0.013
200-13022-1	SCREW,HEX. 8.8 M 6X 25CF	M6	25	10	19	-	Steel, galvanized	7	0.015
200-13037-3	SCREW,HEX. 8.8 M 6X 60CF	M6	60	10	53	-	Steel, galvanized	14	0.031
200-12553-4	SCREW,HEX. 8.8 M 8X 20CF	M8	20	13	11	-	Steel, galvanized	12	0.026
200-10406-7	SCREW,HEX. 8.8 M 8X 25CF	M8	25	13	16	-	Steel, galvanized	13	0.029
200-12007-6	SCREW,HEX. 8.8 M 8X 30CF	M8	30	13	21	-	Steel, galvanized	15	0.033
200-12553-8	SCREW,HEX. 8.8 M 8X 40CF	M8	40	13	31	-	Steel, galvanized	18	0.04
200-12399-2	SCREW,HEX. 8.8 M 8X80CF	M8	80	13	71	-	Steel, galvanized	34	0.075
200-12523-3	SCREW,HEX. 8.8 M10X 40CF	M10	40	16	39	-	Steel, galvanized	30	0.066
200-12009-7	SCREW,HEX. 8.8 M12X 40CF	M12	40	18	28	-	Steel, galvanized	34	0.075
DIN7513-BM4x20	SELF-TAPPING SCREW	M4	20	7	-	-	Steel, galvanized	2	0.004
DIN7513-BM4x25	SELF-TAPPING SCREW	M4	25	7	-	-	Steel, galvanized	2	0.004
206-12124-3	SCREW,SELF-TAPP C15 BM 5.0X 10	M5	10	8,5	-	-	Steel, galvanized	2	0.004
206-12125-4	SCREW,SELF-TAPP C15 BM 6.0X 16Z	M6	16	10	-	-	Steel, galvanized	5	0.011
DIN7513-BM6x25	SELF-TAPPING SCREW	M6	25	10	-	-	Steel, galvanized	6	0.013
DIN912-M3x8-A4	SCREW,SOCK,HEX. A4 M 3X 8	M3	8	5,5	-	-	Stainless steel	1	0.002
DIN912-M4x12-A4	SCREW,SOCK,HEX. A4 M 4X 12	M4	12	7	-	-	Stainless steel	2	0.004
DIN912-M5x10-A2	SCREW,SOCK,HEX. A4 M 5X 10	M5	10	7	-	-	Stainless steel	2	0.004

Couplings

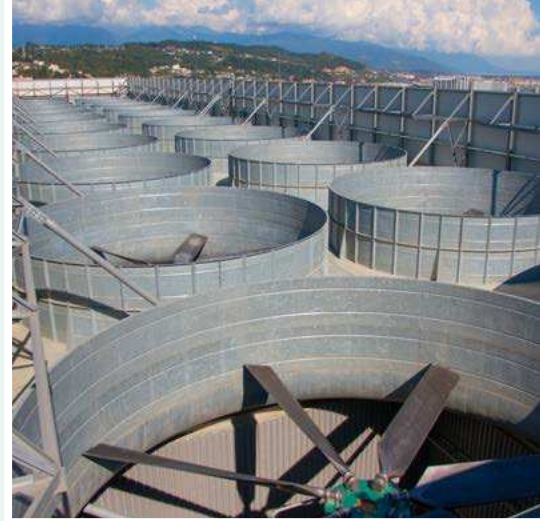

Description

Couplings for hydraulic or lubrication systems are required whenever a virtually leakage-free flow of media is to be separated or distributed. Typically, this happens e.g. when a pump is used to fill several lubricant reservoirs and must be connected and disconnected again and again.

For each coupling design/model, a corresponding hose is required. Conveniently, the coupling side is on the hose of the filling pump and the counterpart, the coupling nipple, is attached to the reservoir. Another coupling application in the field of lubrication systems is the coupling and uncoupling of groups of machines that need not be continuously supplied by one lubrication pump, e.g. for vehicle lubrication and trailer lubrication.

When selecting a coupling, the maximum possible pump/system pressure must be considered. In addition, there are couplings suitable mainly for either indoor or outdoor applications. If the application is not accurately defined before ordering, stainless steel or surface-treated couplings are the best choice. Couplings protect hydraulic fluids or lubricants for contamination and allow quick and high-pressure media flows.

Features and benefits

- Wide product range with different pressure rates and sizes
- Available for filling as well as for operation of automatic lubrication systems
- Quick couplings (ESK) for under-pressure coupling available
- Virtually leakage-free filling

Applications

- All kinds of lubrication systems
- Printing and packaging machines
- Construction and mining
- Metal forming machines
- Vehicles, trucks, loaders
- Agriculture machinery
- General industry
- Machine tools
- Etc.

Couplings

Low-pressure quick-disconnect couplings

Coupling, complete

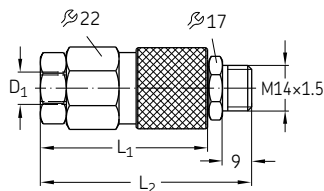

Outer coupling member

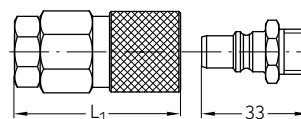

Inner coupling member

Order number	Designation	Tube \varnothing D ₁ ¹⁾		L ₁	L ₂	Material	Operating pressure max.		Weight	
		mm	mm				bar	psi	g	lb
207-168-2	COUPLING, COMPLETE	6	M10x1	–	65	Steel, galvanized	45	653	150	0.33
207-188-2	COUPLING, COMPLETE	8	M14x1,5	–	71,5	Steel, galvanized	45	653	152	0.34
207-168.U7	OUTER COUPLING MEMBER	6	–	51,5	–	Steel, galvanized	45	653	120	0.26
207-188.U11	OUTER COUPLING MEMBER	8	–	58	–	Steel, galvanized	45	653	130	0.29
207-168.U2	INNER COUPLING MEMBER	–	–	–	–	Steel, galvanized	45	653	22	0.05

Both coupling members are shut off when disconnected!

¹⁾ Ports tapped for solderless tube connection

Medium and high-pressure quick-disconnect couplings

995-001-525, 995-001-526

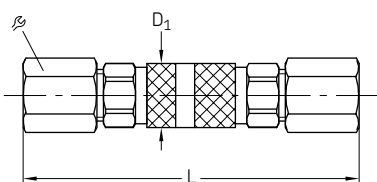

626-26246-1

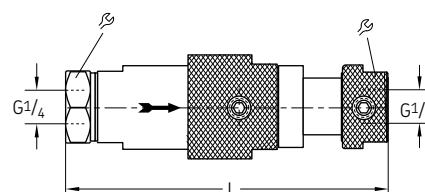

Order number	Designation	Tube \varnothing D ₁		L	R	Material	Operating pressure max.		Weight	
		mm	mm				bar	psi	g	lb
995-001-525	PLUG AND SOCKET COUPLING, TUBE 4	4	10	68	10	Steel, galvanized	100	1 450	30	0.07
995-001-526	PLUG AND SOCKET COUPLING, TUBE 6	6	15	80	12	Steel, galvanized	100	1 450	35	0.08
626-26246-1	COUPLING ESK R1/4I D	–	–	124	27	Steel, galvanized	300	4 351	760	1.68

Couplings

Coupling plugs

995-001-096

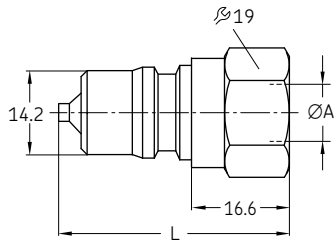

995-001-501

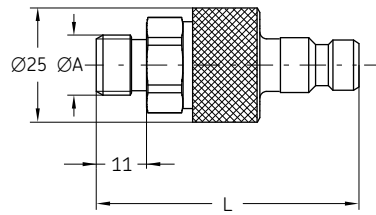

995-000-705

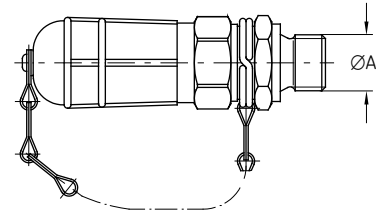

995-001-260

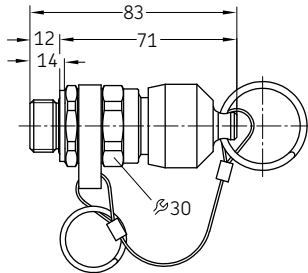

995-001-950

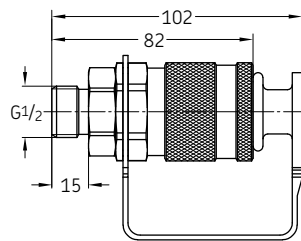

995-001-500

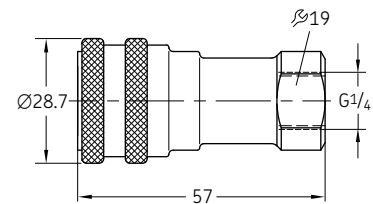

Order number	Designation	Material	ØA	L	Respective dust cover Order number	Respective coupling socket Order number	Operating pressure max.		Weight	
							bar	psi	g	lb
995-001-096	COUPLING PLUG G1/4 350 BAR	Steel, galvanized	G 1/4	39	995-001-235	–	350	5 080	60 ¹⁾	0.13 ¹⁾
995-001-501	COUPLING PLUG G1/4 200 BAR	Steel, galvanized	G 1/4	57.5	995-001-503	995-002-073	200	2 900	305 ²⁾	0.67 ²⁾
995-001-502	COUPLING PLUG G1/2 250 BAR	Steel, galvanized	G 1/2	82	995-001-504	995-001-950	250	3 600	1 050 ²⁾	2.32 ²⁾
995-000-705	COUPLING PLUG G1/4 70 BAR	Steel, galvanized	G 1/4	–	–	995-001-500	70	1 000	233 ³⁾	0.51 ³⁾
995-001-260	COUPLING PLUG G1/2	Steel, galvanized	G 1/2	83	–	–	–	–	229	0.50

¹⁾ weight for plug + dust cover

²⁾ weight for complete coupling

³⁾ weight for plug + coupling socket

Couplings

Coupling sockets with return flow port

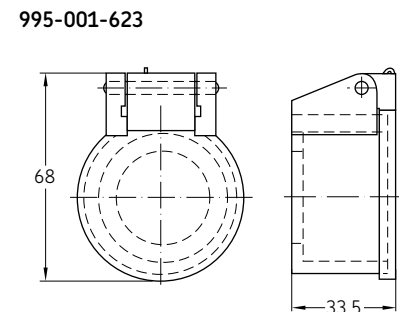
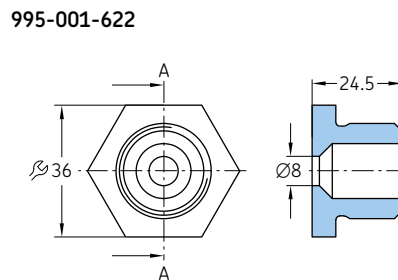
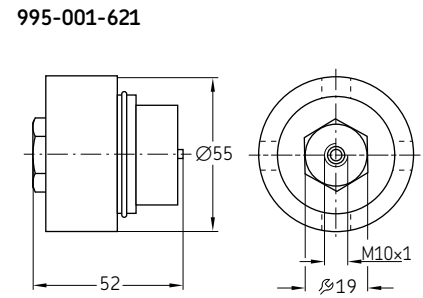
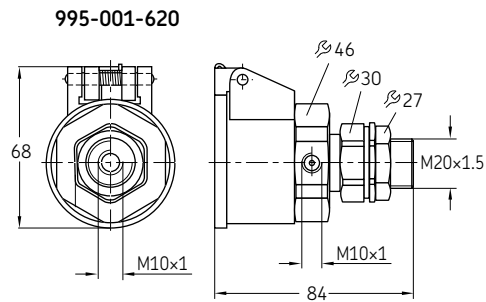

Order number	Designation	Material	Operating pressure max.		Weight	
			bar	psi	g	lb
995-001-620	COUPLING SOCKET	Steel, galvanized	100	1 450	480	1.06
995-001-621	RESPECTIVE COUPLING PLUG	Steel, galvanized	100	1 450	380	0.84
995-001-622	RESPECTIVE STUB	Steel, galvanized	100	1 450	100	0.22
995-001-623	RESPECTIVE DUST COVER	Steel, galvanized	100	1 450	55	0.12

Valves



Description

Several kind of valves are usually needed to operate automatic lubrication systems accurately. Intermittent or subsectioned systems only work, if the right valves are installed. Valves specifically used in just one SKF system, such as in single-line lubrication systems, can be selected out of the respective SKF automatic lubrication system catalogues.

This catalogue chapter contains valves for use in multiple systems:

- Shut-off valves
- Safety valves
- Check valves
- Relief valves

In several applications, necessary valves may also come directly integrated in the pump unit, mounted in a valve block or as part of a reservoir unit.

Features and benefits

- System component protection against excessive pressure and destruction
- Cost-efficient operation due to lubrication system subsectioning
- Shut-off valves allow manual activation or deactivation of independently operating machine zones

Applications

- Small-to-medium machine tools
- Mobile on-road (fleet vehicles, on-road vehicles)
- Assembly/Automation, food packaging, part assembly lines
- Pulp and paper industry
- Injection molding
- General industry
- Heavy industry
- Etc.

Relief valve

Connection diagram

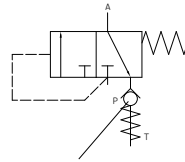

Check valve = residual pressure valve 0.5 bar

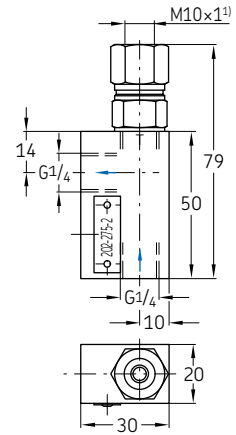

Order number	Designation	Residual pressure		Weight	
		bar	psi	g	lb
202-275-2	PRESS, RELIEF VALVE 0,5 BAR, G1/4	0,5	7.25	240	0.53

Relief valves with bleed valve and safety valve

Fitted to reservoir

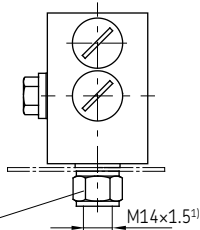

For P and R
2 adapters each 408-160
washers 508-108

¹⁾ Ports tapped for solderless tube connection

Relief valve circuit diagram

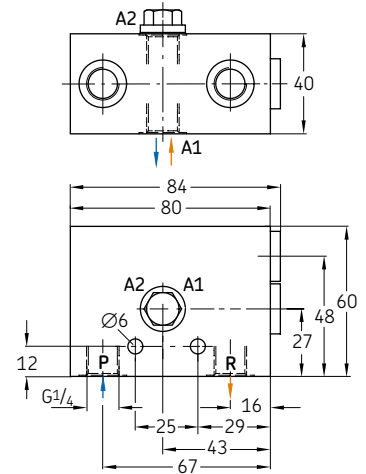
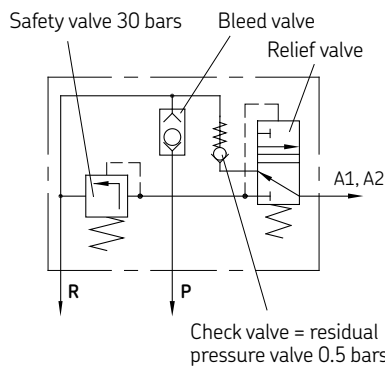

Order number	Designation	Tube Ø	Material	Residual pressure		Weight	
				bar	psi	g	lb
202-175-30	PRESS. RELIEF VALVE 30 BAR, R1/4	–	Aluminium	30	435	570	1.26
Adaptors ¹⁾							
406-054	CONNECTING PIECE ST 6 - G1/4AZN	6	Steel, galvanized	–	–	20	0.04
301-020	CONNECTING PIECE ST 8 - G1/4AZN	8	Steel, galvanized	–	–	16	0.04
410-163	CONNECTING PIECE ST 10 - G1/4AZN	10	Steel, galvanized	–	–	30	0.07

¹⁾ Ports tapped for solderless tube connection

A = Outlet; P = Inlet; T (R) = Return

Valves

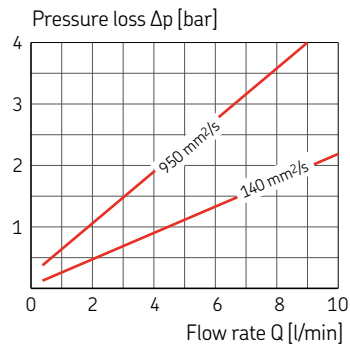
Pressure regulating valves, adjustable
(poppet valve)

With increasing flow rate, the pressure upstream from the valve will also rise in accordance with the curves.

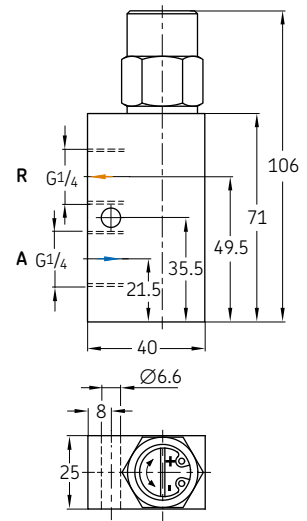

Order number	Designation	Adjustable pres. range		Operating pres. max.		Oil temperature		Viscosity range	Seal	Material	Weight	
		bar	psi	bar	psi	°C	°F				mm ² /s	g
WVN200-10E6	PRES.REGUL.VALVE 1-6 BAR NBR	1 to 6	14,5 to 87	40	580	80	176	20 to 1000	NBR	Steel, galvanized	500	1.10
WVN200-10E12	PRES.REGUL.VALVE 3-12 BAR NBR	3 to 12	43,5 to 174	40	580	80	176	20 to 1000	NBR	Steel, galvanized	500	1.10
WVN200-10E12-S8	PRES.REGUL.VALVE 3-12 BAR FPM	3 to 12	43,5 to 174	40	580	80	176	20 to 1000	FPM	Steel, galvanized	500	1.10
WVN200-10E25	PRES.REGUL.VALVE 4-25 BAR NBR	4 to 25	58 to 363	40	580	80	176	20 to 1000	NBR	Steel, galvanized	500	1.10
WVN200-10E25-S8	PRES.REGUL.VALVE 4-25 BAR FPM	4 to 25	58 to 363	40	580	80	176	20 to 1000	FPM	Steel, galvanized	500	1.10
WVN200-10E35	PRES.REGUL.VALVE 4-35 BAR NBR	4 to 35	58 to 510	40	580	80	176	20 to 1000	NBR	Steel, galvanized	510	1.12
WVN200-10E60	PRES.REGUL.VALVE 12-60 BAR NBR	12 to 60	174 to 870	70	1 015	80	176	20 to 1000	NBR	Steel, galvanized	510	1.12
WVN200-10E60-S8	PRES.REGUL.VALVE 12-60 BAR FPM	12 to 60	174 to 870	70	1 015	80	176	20 to 1000	FPM	Steel, galvanized	510	1.12

General characteristics Design: poppet valve with hydraulic cushioning directly controlled
Lubricant: oil
Connecting thread: G 1/4
Mounting position: optional

Adapters for valves

Fitted to reservoir

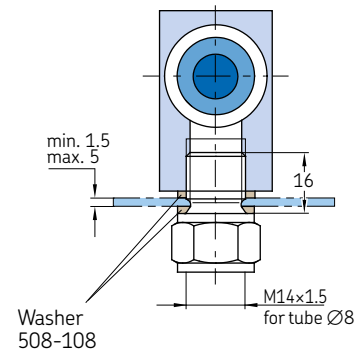

Order number	Designation	Description	Tube ØD	Material	Weight	
					mm	g
301-020	CONNECTING PIECE ST 8 - G1/4A ZN	for valves WVN200-10E6 ...10E35	8	Steel, galvanized	16	0.04
410-163	CONNECTING PIECE ST 10 - G1/4A ZN	for valves WVN200-10E6 ...10E35	10	Steel, galvanized	30	0.07
412-163	CONNECTING PIECE ST 12 - G1/4A ZN	for valves WVN200-10E6 ...10E35	12	Steel, galvanized	51	0.11
508-108	SEALING RING CU 13.3X17.9X1.5	for valves WVN200-10E6 ...10E35	-	Copper	1	0.00
223-12477-6	FITTING GE 8-L G 1/4 CF	for valve WVN200-10E60	8	Steel, galvanized	35	0.08
223-12272-9	FITTING GE 10-L G 1/4 CF	for valve WVN200-10E60	10	Steel, galvanized	41	0.09
508-108	SEALING RING CU 13.3X17.9X1.5	for valve WVN200-10E60	-	Copper	1	0.00
408-160	CONNECTING PIECE ST 8 - G1/4A ZN	adapters with long tube ends	-	Steel, galvanized	22	0.05

Valves

Pressure regulating valves, fixed pressure

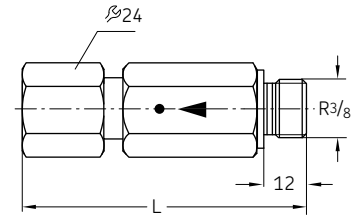

Order number	Designation	L	Material	Operating pressure max.		Weight	
				bar	psi	g	lb
624-25465-1	VALVE SV -120-G3/8A Z	88	Steel, galvanized	120	1 740	241	0.53
624-25294-1	VALVE SV -350-G3/8A Z	84	Steel, galvanized	350	5 075	241	0.53
624-27092-1	VALVE SV -410-G3/8A Z	82	Steel, galvanized	410	5 950	241	0.53



Order number	Designation	Pipe stud ØD	Material	Operating pressure max.		Weight	
				bar	psi	g	lb
624-25478-1	VALVE SVP -200-S 6	6	Steel, galvanized	200	2 900	237	0.52
624-25479-1	VALVE SVP -350-S 6	6	Steel, galvanized	350	5 075	236	0.52
624-25480-1	VALVE SVP -200-S 8	8	Steel, galvanized	200	2 900	240	0.53
625-25481-1	VALVE SVP -350-S 8	8	Steel, galvanized	350	5 075	240	0.53
624-25482-1	VALVE SVP -200-S 10	10	Steel, galvanized	200	2 900	240	0.53
624-25483-1	VALVE SVP -350-S 10	10	Steel, galvanized	350	5 075	260	0.57

Valves

Pressure regulating valves (ball valves)

For flow rates from 0.5–2 l/min

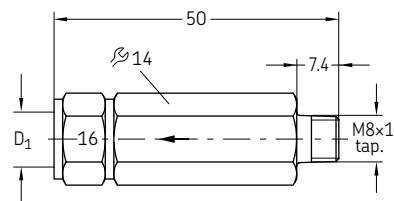

Order number	Designation	Tube Ø		Opening pressure		Marking	Material	Weight	
		D ₁ ¹⁾		bar	psi			g	lb
WVN200-4A0.4	PRES.REGUL.VALVE 0.4 BAR, Ø 4	4	M8×1	0,4	5,8	0,4	Steel, galvanized	45	0.10
WVN200-4A5	PRES.REGUL.VALVE 5 BAR, Ø 4	4	M8×1	5	72,5	5	Steel, galvanized	47	0.10
WVN200-4A8	PRES.REGUL.VALVE 8 BAR, Ø 4	4	M8×1	8	116	8	Steel, galvanized	46	0.10
WVN200-4A12	PRES.REGUL.VALVE 12 BAR, Ø 4	4	M8×1	12	174	12	Steel, galvanized	45	0.10
WVN200-4A16	PRES.REGUL.VALVE 16 BAR, Ø 4	4	M8×1	16	232	16	Steel, galvanized	46	0.10
WVN200-4A25	PRES.REGUL.VALVE 25 BAR, Ø 4	4	M8×1	25	360	25	Steel, galvanized	46	0.10
WVN200-4A0.4-S1	PRES.REGUL.VALVE 0.4 BAR, Ø 6	6	M10×1	0,4	5,8	0,4	Steel, galvanized	48	0.11

1) Ports tapped for solderless tube connection

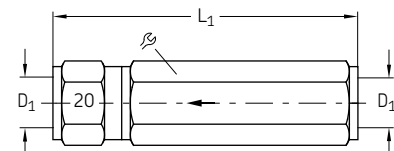

Order number	Designation	Tube Ø		L ₁	Ø	Opening pressure		Marking	Material	Weight	
		D ₁ ¹⁾				bar	psi			g	lb
WVN200-6B0.5	PRES.REGUL.VALVE 0,5 BAR, Ø 6	6	M10×1	61	14	0,5	7,25	5	Steel, galvanized	57	0.13
WVN200-6B3	PRES.REGUL.VALVE 3 BAR, Ø 6	6	M10×1	61	14	3	43,5	3	Steel, galvanized	58	0.13
WVN200-6B8	PRES.REGUL.VALVE 8 BAR, Ø 6	6	M10×1	61	14	8	116	8	Steel, galvanized	58	0.13
WVN200-6B12	PRES.REGUL.VALVE 12 BAR, Ø 6	6	M10×1	61	14	12	174	12	Steel, galvanized	59	0.13
WVN200-6B16	PRES.REGUL.VALVE 16 BAR, Ø 6	6	M10×1	61	14	16	232	16	Steel, galvanized	60	0.13
WVN200-6B20	PRES.REGUL.VALVE 20 BAR, Ø 6	6	M10×1	61	14	20	290	20	Steel, galvanized	60	0.13
WVN200-6B40	PRES.REGUL.VALVE 40 BAR, Ø 6	6	M10×1	61	14	40	580	40	Steel, galvanized	59	0.13
WVN200-8B0	PRES.REGUL.VALVE 0.04 BAR, Ø 8	8	M14×1,5	71	17	0,04	0,58	0	Steel, galvanized	86	0.19
WVN200-8B3	PRES.REGUL.VALVE 3 BAR, Ø 8	8	M14×1,5	71	17	3	43,5	3	Steel, galvanized	87	0.19
WVN200-8B5	PRES.REGUL.VALVE 5 BAR, Ø 8	8	M14×1,5	71	17	5	72,5	5	Steel, galvanized	89	0.20
WVN200-8B12	PRES.REGUL.VALVE 12 BAR, Ø 8	8	M14×1,5	71	17	12	174	12	Steel, galvanized	89	0.20
WVN200-8B16	PRES.REGUL.VALVE 16 BAR, Ø 8	8	M14×1,5	71	17	16	232	16	Steel, galvanized	84	0.19
WVN200-8B20	PRES.REGUL.VALVE 20 BAR, Ø 8	8	M14×1,5	71	17	20	290	20	Steel, galvanized	90	0.20
WVN200-8B32	PRES.REGUL.VALVE 32 BAR, Ø 8	8	M14×1,5	71	17	32	464	32	Steel, galvanized	93	0.21
WVN200-10B0	PRES.REGUL.VALVE 0.04 BAR, Ø 10	10	M16×1,5	80	19	0,04	0,58	0	Steel, galvanized	100	0.22
WVN200-10B0.5	PRES.REGUL.VALVE 0.5 BAR, Ø 10	10	M16×1,5	80	19	0,5	7,25	5	Steel, galvanized	126	0.28
WVN200-10B1	PRES.REGUL.VALVE 12 BAR, Ø 10	10	M16×1,5	80	19	1,2	17,4	12	Steel, galvanized	128	0.28
WVN200-10B32	PRES.REGUL.VALVE 32 BAR, Ø 10	10	M16×1,5	80	19	32	464	32	Steel, galvanized	130	0.29
161-212-054 ²⁾	PRES.REGUL.VALVE 20 BAR, Ø 8	10	M14×1,5	84,5	17	20	290	20	Steel, galvanized	107	0.24

¹⁾ Ports tapped for solderless tube connection

²⁾ This valve is designed as a plunger valve. Because of this design it can also be used for regulating tasks, whereas the ball valves should be used as safety valves.

Valves

Shut-off valves

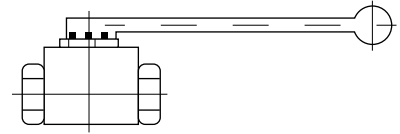

Order number	Designation	p max.		Connection	Nominal Ø DN	Material	Weight	
		bar	psi				g	lb
235-13108-4	BALL VALVE ST G 1/2I DN13 500 BAR	500	7 250	G 1/2 female	13	Steel, galvanized	640	1.41
235-13114-1	BALL VALVE ST D20 DN16 400 BAR	400	5 800	Tube Ø 20	16	Steel, galvanized	960	2.12

Direction of flow optional

161-600-036

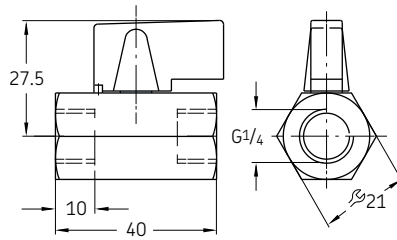

UFZ.0097

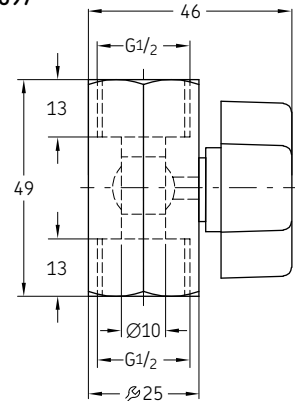

Order number	Designation	p max.		Max. temperature		Material	Weight	
		bar	psi	°C	°F		g	lb
161-600-036	BALL VALVE BRASS, G1/4 I, 16 BAR	16	232	90	194	Brass	80	0.18
UFZ.0097	BALL VALVE BRASS, G1/2 I, 10 BAR	10	145	90	194	Brass	150	0.33

Direction of flow optional

Solenoid valves

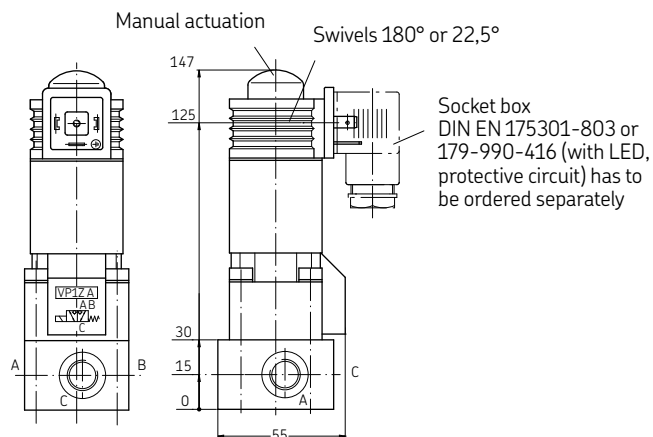

Order number	Designation	Type	Off Position	Operating voltage	Con- nection	p max.		Weight	
						bar	psi	g	lb
525-32080-1	WAY VALVE WV-M-W2G-1/2- 24DC	2/2 way valve	normally closed	24 VDC	G 1/2	400	5 800	1,74	3.84
525-32082-1	WAY VALVE WV-M-W2G-1/2-230AC	2/2 way valve	normally closed	230 VAC	G 1/2	400	5 800	1,7	3.75
525-32081-1	WAY VALVE WV-M-W2G-1/2-110AC	2/2 way valve	normally closed	110 VAC	G 1/2	400	5 800	1,76	3.88
525-32083-1	WAY VALVE WV-M-W2O-1/2- 24DC	2/2 way valve	normally open	24 VDC	G 1/2	400	5 800	1,76	3.88
525-32084-1	WAY VALVE WV-M-W2O-1/2-230AC	2/2 way valve	normally open	230 VAC	G 1/2	400	5 800	1,69	3.73
525-32098-1	WAY VALVE WV-M-W2O-1/2-110AC	2/2 way valve	normally open	110 VAC	G 1/2	400	5 800	1,81	3.99
525-32085-1	WAY VALVE WV-M-W3 -3/8- 24DC	3/2 way valve	-	24 VDC	G 3/8	400	5 800	1,37	3.02
525-32087-1	WAY VALVE WV-M-W3 -3/8-230AC	3/2 way valve	-	230 VAC	G 3/8	400	5 800	1,3	2.87
525-32086-1	WAY VALVE WV-M-W3 -3/8-110AC	3/2 way valve	-	110 VAC	G 3/8	400	5 800	1,38	3.04
161-110-031+924	WAY VALVE WV-M-W2G-1/4- 24DC	2/2 way valve	normally closed	24 VDC	G 1/4	500	7 250	1,28	2.82
161-120-064+924	WAY VALVE WV-M-W3 -1/4- 24DC	3/2 way valve	-	24 VDC	G 1/4	500	7 250	1,25	2.76

Pressure gauges

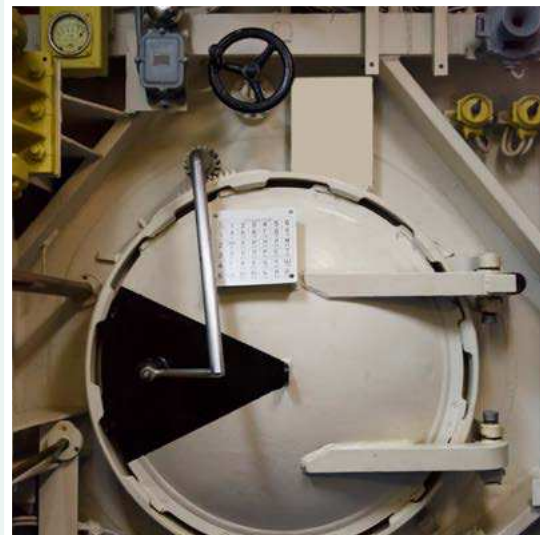

Description

Pressure gauges are mechanically operated instruments that measure the pressure of the connected medium. In lubrication systems, they are used to show the pressure rate of air, oil or grease of either the pump or the pipe system. They are available in various pressure ranges for low-, medium- or high-pressure applications in all kinds of lubrication systems.

The following points must be considered in order to select the correct model:

- Pressure of the medium – the maximum pressure that could occur in the system shall not be higher than 2/3 of the indication range of the pressure range
- Pulsation of the pressure – use of liquid filled gauges is highly recommended for measuring points with high dynamic pressure loads and areas with vibration
- Corrosive atmosphere – use of stainless steel pressure gauges is highly recommended
- If an electrical signal is desired – use of pressure gauges, including digital pressure indication, is highly recommended

Features and benefits

- Visual and digital pump and system pressure monitoring
- Economical, reliable and virtually maintenance-free operation
- Wide range of pressure rates and sizes
- Liquid-filled gauges for dynamic operations available
- Stainless for operation in aggressive atmosphere available

Applications

- All kinds of lubrication systems: low, middle mechanic and plant engineering
- Oil and grease lubrication systems
- Installation at the pump or at the end of the line

Pressure gauges

Standard pressure gauges

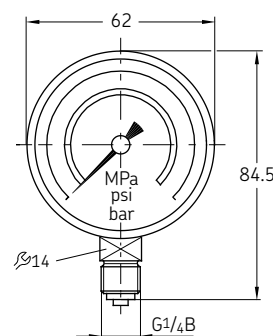

Order number	Designation	Indication range		Material	Weight	
		bar	psi		g	lb
169-101-004	PR.GAUGE D63 0-10 BAR G1/4 ABS	0-10	0-145	ABS housing	96	0.21
169-102-020 ²⁾	PR.GAUGE D63 0-25 BAR G1/4 ABS	0-25	0-360	ABS housing	90	0.20
169-104-020 ²⁾	PR.GAUGE D63 0-40 BAR G1/4 ABS	0-40	0-580	ABS housing	100	0.22
169-106-020 ²⁾	PR.GAUGE D63 0-60 BAR G1/4 ABS	0-60	0-870	ABS housing	83	0.18
169-110-020 ²⁾	PR.GAUGE D63 0-100 BAR G1/4 ABS	0-100	0-1450	ABS housing	90	0.20
169-116-000	PR.GAUGE D63 0-160 BAR G1/4 ABS	0-160	0-2320	ABS housing	94	0.21
169-125-020 ²⁾	PR.GAUGE D63 0-250 BAR G1/4 ABS	0-250	0-3625	ABS housing	84	0.19

Washer, order No. 248-610.02, must be ordered separately for use in solderless tube connections acc. to DIN 3862.

²⁾ Associated connecting pieces → page 60

Damped pressure gauges with restrictor

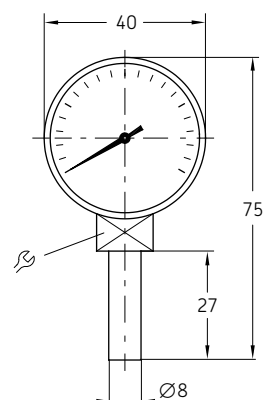

Order number	Designation	∅	Restrictor	Lubricant	Indication range		Material	Weight	
					bar	psi		g	lb
248-602.25	PR.GAUGE D40 0-10 BAR TUBE 8	4kt 12	-	-	0-10	0-145	Steel housing, black	66	0.15
169-102-506 ¹⁾	PR.GAUGE D40 0-25 BAR TUBE 8	12	0,4	-	0-25	0-360	Steel housing, black	62	0.14
248-602.20	PR.GAUGE D40 0-40 BAR TUBE 8	12	-	Grease	0-40	0-580	Steel housing, black	59	0.13
169-104-008 ¹⁾	PR.GAUGE D40 0-40 BAR TUBE 8	4kt 14	0,4	Oil	0-40	0-580	Steel housing, black	61	0.13
169-106-004	PR.GAUGE D40 0-60 BAR TUBE 8 ABS	4kt 14	-	-	0-60	0-870	ABS housing	60	0.13

Fixed by means of a double tapered sleeve and socket union (solderless tube connection) in counterbore acc. to DIN 3854/DIN 3862.

¹⁾ damped design

Pressure gauges

Damped pressure gauges with glycerine filling

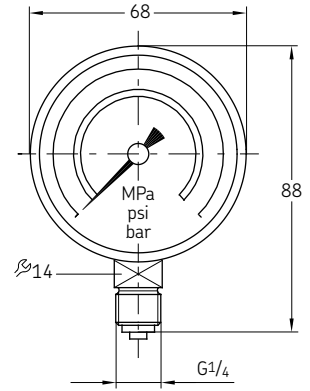

Order number	Designation	Mounting position	Indication range		Material	Weight	
			bar	psi		g	lb
169-102-015	PR.GAUGE D68 0- 25 BAR GLYCER (G1/4) VA	vertically	0-25	0-360	Stainless steel housing	210	0.46
169-104-015	PR.GAUGE D68 0- 40 BAR GLYCER (G1/4) VA	vertically	0-40	0-580	Stainless steel housing	200	0.44
169-106-015	PR.GAUGE D68 0- 60 BAR GLYCER (G1/4) VA	vertically	0-60	0-870	Stainless steel housing	200	0.44
169-110-015	PR.GAUGE D68 0-100 BAR GLYCER (G1/4) VA	vertically	0-100	0-1 450	Stainless steel housing	200	0.44
169-125-015	PR.GAUGE D68 0-250 BAR GLYCER (G1/4) VA	vertically	0-250	0-3 625	Stainless steel housing	200	0.44
169-140-001	PR.GAUGE D62 0-400 BAR GLYCER (G1/4) VA	vertically	0-400	0-5 800	Stainless steel housing	220	0.49

Washer, order No. 248-610.02, must be ordered separately for use in solderless tube connections acc. to DIN 3862.

Damped pressure gauges with glycerin filling and visualization in red/green

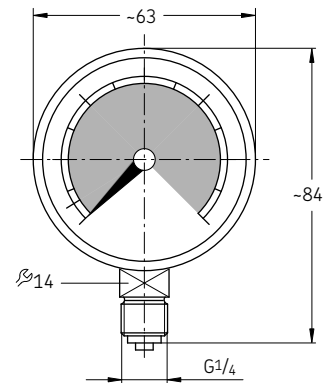

Order number	Designation	Mounting position	Indication range		Material	Weight	
			bar	psi		g	lb
169-101-607	PR.GAUGE D63 0-16 BAR GLYZ. G1/4 VA	vertically	0-16	0-230	Stainless steel housing	166	0.37
169-106-011	PR.GAUGE D63 0-60 BAR GLYZ. G1/4 VA	vertically	0-60	0-870	Stainless steel housing	220	0.49
169-110-010	PR.GAUGE D63 0-100 BAR GLYZ. G1/4 VA	vertically	0-100	0-1 450	Stainless steel housing	174	0.38

Washer, order No. 248-610.02, must be ordered separately for use in solderless tube connections acc. to DIN 3862.

Pressure gauges

High-pressure gauges

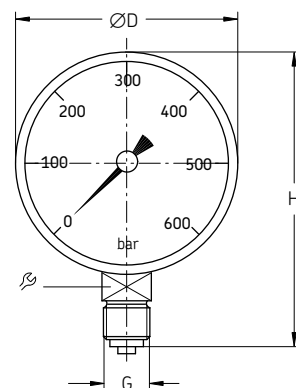

Order number	Designation	ØD	G	H	Mounting position	Indication range		Material	Weight	
						bar	psi		g	lb
Steel housing, black										
234-13132-7	PR.GAUGE D 63 0- 400 BAR GLYZ.G1/4B BOT	63	G 1/4 bottom	84,5	vertically	0-400	0-5800	Steel housing, black	200	0,44
234-13132-8	PR.GAUGE D 63 0- 400 BAR G1/4	63	G 1/4 bottom	84,5	vertically	0-400	0-5800	Steel housing, black	100	0,22
234-13156-6	PR.GAUGE D 63 0- 600 BAR (G1/4A)	63	G 1/4 bottom	84,5	vertically	0-600	0-8700	Steel housing, black	210	0,46
234-13182-7	PR.GAUGE D 63 0- 600 BAR GLYZ.G1/4B BOT	63	G 1/4 bottom	84,5	vertically	0-600	0-8700	Steel housing, black	200	0,44
234-10396-2	PR.GAUGE D100 0- 400 BAR (G1/2A)	100	G 1/2 bottom	133	vertically	0-400	0-5800	Steel housing, black	601	1,33
234-13101-2	PR.GAUGE D100 0- 600 BAR (R1/2)	100	G 1/2 bottom	133	vertically	0-600	0-8700	Steel housing, black	560	1,23
234-13101-4	PR.GAUGE D100 0- 600 BAR GLYZER	100	G 1/2 bottom	133	vertically	0-600	0-8700	Steel housing, black	860	1,90
Stainless steel housing										
234-10396-9	PR.GAUGE D 63 0- 400 BAR G1/4(BAR/PSI)VA	63	G 1/4 bottom	84,5	vertically	0-400	0-5800	Stainless steel housing	200	0,44
234-13182-8	PR.GAUGE D 63 0- 400BAR G1/4B BACK VA	63	G 1/4 back	63	vertically	0-400	0-5800	Stainless steel housing	220	0,49
234-10898-4	PR.GAUGE D100 0- 400 BAR+PSI GLYZ.1.4404	100	G 1/2 bottom	133	vertically	0-400	0-5800	Stainless steel housing	993	2,19
234-13136-2	PR.GAUGE D100 0- 600 BAR HOUSING VA	100	G 1/2 bottom	133	vertically	0-600	0-8700	Stainless steel housing	600	1,32

Reservoirs



Description

For technical reasons, all reservoirs shown in this catalogue can only be used for oil. Grease reservoirs require additional technical features that make a combination of reservoir and pump necessary. The reservoirs shown are available in either plastic or metal designs. The advantage of the plastic containers is that the oil filling level is clearly visible through the transparent reservoir. Metal reservoirs from 6 litres and larger can be equipped with external oil level indicators. It is also possible to monitor the minimum or maximum oil level electrically via float switches. Depending on the oil used, the sealing material (NBR or FPM) should be selected.

Features and benefits

- Available in sizes ranging, from 3 litres to 100 litres on request
- All reservoirs are equipped with a screen at the filler socket (exception: 1 litre tank screen at the outlet), which reliably prevents foreign particles from entering
- Simple and proven design for use in all kinds of automatic oil lubrication systems
- Virtually leakage-free storage of oil
- Easy manual or digital fill-level monitoring

Applications

- All automatic oil lubrication systems
- Pulp and paper industry
- Automobile presses
- Food and beverage
- Automation
- Printing
- Metals
- Etc.

Reservoirs

Plastic reservoirs

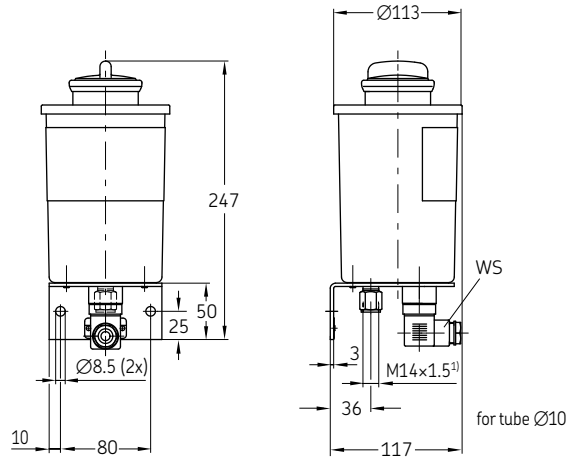

1) Ports tapped for solderless tube connection

Order number	Designation	Reservoir Capacity		Level indicator WS	Type of contact	Seal material	Weight	
		l	gal.				kg	lb
K1	OIL RESERVOIR ASSY. KF 1YN	1	0.26	–	–	NBR	0,70	1.54
KW1	OIL RESERVOIR ASSY. KF 1YL (NO)	1	0.26	Min. filling level	NO	NBR	0,76	1.68
KW1-S2	OIL RESERVOIR ASSY. KF 1YL (NC)	1	0.26	Min. filling level	NC	NBR	0,80	1.76

Plastic reservoir, 3 liter

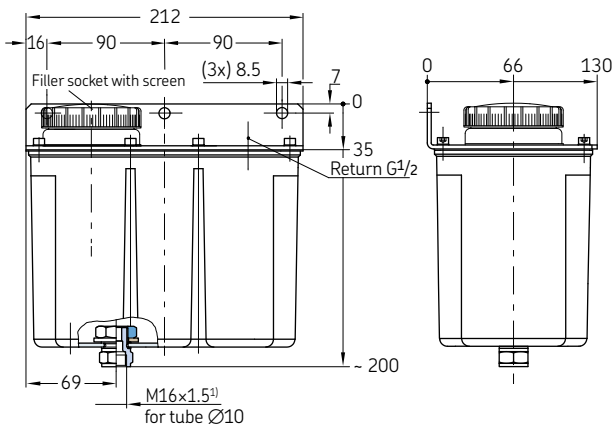

1) Ports tapped for solderless tube connection

Plastic reservoir, 6 liter

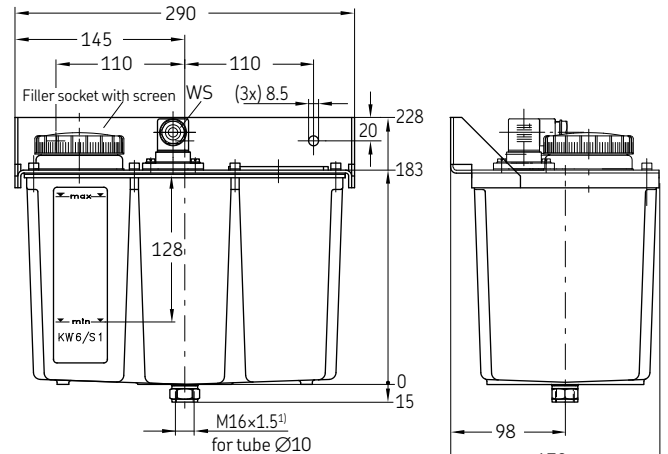

1) Ports tapped for solderless tube connection

Order number	Designation	Reservoir Capacity		Level indicator WS	Type of contact	Seal material	Weight	
		l	gal.				kg	lb
K3-S2	OIL RESERVOIR ASSY. KF 3YN	3	0.79	–	–	NBR	1,34	2.95
KW3-S1	OIL RESERVOIR ASSY. KF 3YL (SPDT)	3	0.79	Min. filling level	Changeover	NBR	1,63	3.59
K6-S5	FLUID GREASE RESERVOIR ASSY. KF 6YN	6	1.58	–	–	NBR	2,28	5.04
K6-S6	OIL RESERVOIR ASSY. KF 6YN	6	1.58	–	–	NBR	2,28	5.04
KW6-S1	OIL RESERVOIR ASSY. KF 6YL (SPDT)	6	1.58	Min. filling level	Changeover	NBR	2,58	5.70
KW6-S2	OIL RESERVOIR ASSY. KF 6YLP (NC)	6	1.58	Min. filling with advance warning	2NCs	NBR	2,50	5.51
KW6-S81	OIL RESERVOIR ASSY. KF 6YL (SPDT)	6	1.58	Min. filling level	Changeover	FPM	2,58	5.70

Reservoirs

Plastic reservoirs

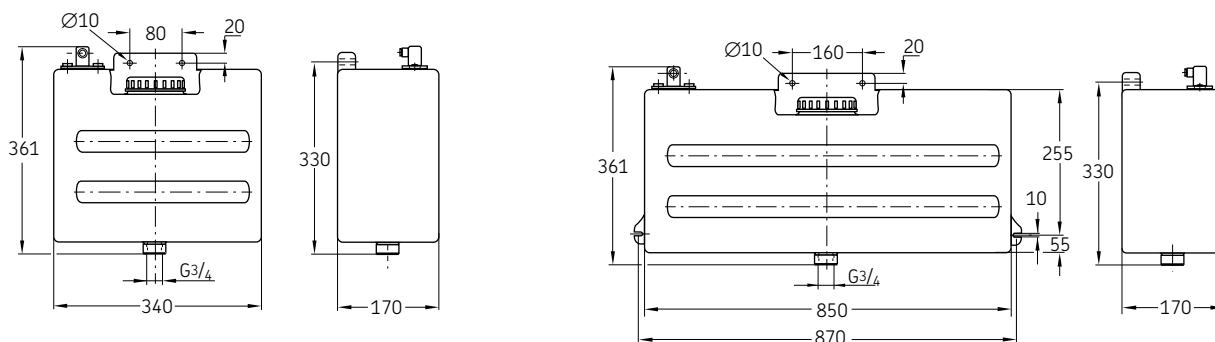

Order number	Designation	Reservoir Capacity		Level indicator WS	Type of contact	Weight	
		l	gal.			kg	lb
651-28691-1	OIL RESERVOIR PL 13YL F.PMA	13	2.86	Minimum filling level	changeover	2,2	4.85
651-29124-1	OIL RESERVOIR PL 13YN F.PMA	13	2.86	–	–	2	4.40
651-28685-1	OIL RESERVOIR PL 36YL F.PMA	36	7.9	Minimum filling level	Changeover	4,251	9.37

Oil trough with shut-off valve

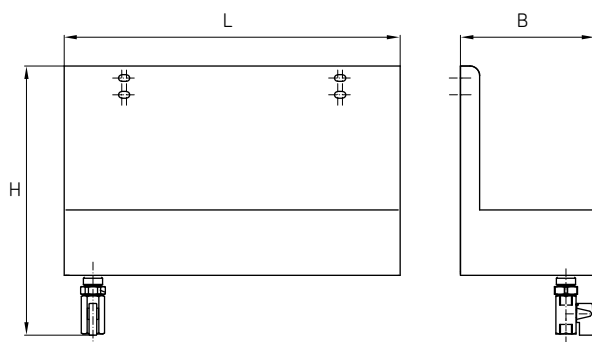

Order number	Designation	Reservoir Capacity				
		L	B	H		
		l	gal.			
B3.U21	OIL TROUGH 3L	3	0,792	350	280	140
B7.U271	OIL TROUGH 6L	6	1,585	400	380	190

Reservoirs

Metal reservoirs

Metal reservoir, 3 liter

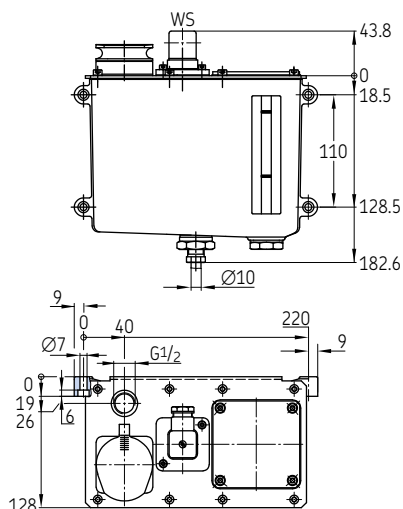

Metal reservoir, 6 liter

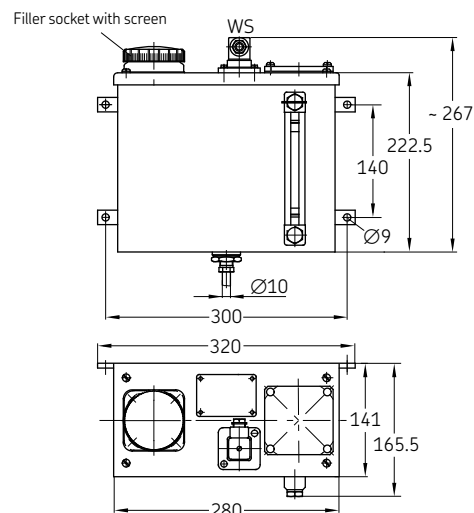

Order number	Designation	Reservoir Capacity		Level indicator WS	Type of contact	Seal material	Weight	
		l	gal.				kg	lb
BW3-2-S1	OIL RESERVOIR ASSY. ST 3YL	3	0.79	Min. filling level	Changeover	NBR	2,24	4.94
B7	OIL RESERVOIR ASSY. ST 6YN	6	1.58	-	-	NBR	4,9	10.80
BW7-S6	OIL RESERVOIR ASSY. ST 6YBN	6	1.58	Min. and max. filling level	2 NCs	NBR	5,12	11.29
BW7-S7	OIL RESERVOIR ASSY. ST 6YLP (2XNC)	6	1.58	Min. filling level with advance warning	2 NCs	NBR	5,2	11.47
BW7-S8	OIL RESERVOIR ASSY. ST 6YL (SPDT)	6	1.58	Min. filling level	Changeover	FPM	5,11	11.27
BW7-S11	OIL RESERVOIR ASSY. ST 6YP (2XSPDT)	6	1.58	Min. filling level with advance warning	1 NO, 1 NC	NBR	4,97	10.96
BW7-S14	OIL RESERVOIR ASSY. ST 6YP (NC/NO))	6	1.58	Min. filling level with advance warning	1 NO, 1 NC	NBR	5,2	11,47
162-310-005	OIL RESERVOIR ASSY. ST 6YL (SPDT)	6	1.58	Min. filling level	Changeover	NBR	4,96	10,94

Oil level gauges for metal reservoirs

Order number	Designation	Reservoir Capacity		Weight			
		L ₁	L ₂	Liters	gal.	g	lb
		mm	mm				
995-003-044	OIL LEVEL GAUGE L=127MM	152	127	6	1.58	146	0.32
995-003-040	OIL LEVEL GAUGE L=165MM	190	165	6	1.58	158	0.35
995-003-041	OIL LEVEL GAUGE L=190MM	215	190	15 and 30	3.96 and 7.92	170	0.37
995-003-042	OIL LEVEL GAUGE L=254MM	279	254	50	13.21	190	0.42
995-003-043	OIL LEVEL GAUGE L=280MM	305	280	100	26.42	199	0.44

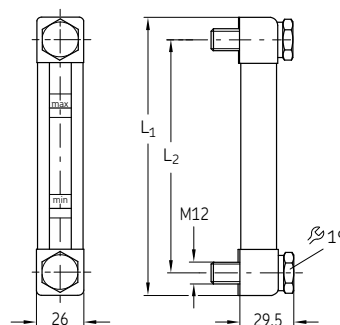

Type: NBR, FKM (FPM) on request

Lubricating nipples



Description

Grease nipples provide a standardized connection to the grease gun and are therefore an important part for servicing and maintaining bearings. They also protect the lubrication point from external influences such as dirt and water.

Features and benefits

- Our standard program includes the most common hydraulic and flat grease nipples according to DIN 74412 and DIN 3404
- Available in galvanized steel or stainless steel

Applications

- Linear guides
- Bearings, bearing blocks
- Drive shafts, cardan shafts
- Axles

Hydraulic grease nipples according to DIN 71412

Straight

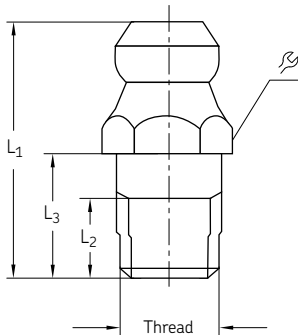

Angle, 45°

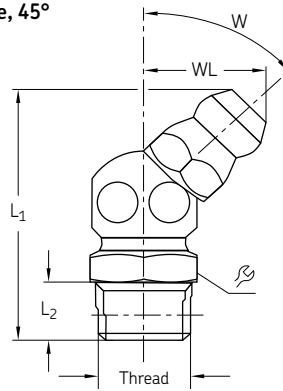

Angle, 90°

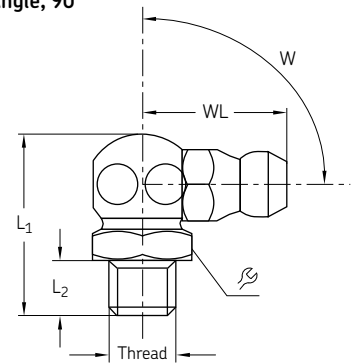

Order number	Designation	Form	Thread	Material	Operating pressure max.		Weight (100 pcs)		
					bar	psi	g	lb	
mm									
Steel, galvanized									
251-14040-1	HYDRAULIC LUBR.FITT. STAR 1/8 Z	Straight	R 1/8	11	Steel, galvanized	350	5 080	600	1.32
996-001-890	HYDRAULIC LUBR.FITT. ST AM 10X1,0Z	Straight	M10x1	11	Steel, galvanized	350	5 080	500	1.10
251-14109-3	HYDRAULIC LUBR.FITT. ST BR 1/4 Z	Angle, 45°	R 1/4	14	Steel, galvanized	350	5 080	1 800	3.97
251-14045-1	HYDRAULIC LUBR.FITT. ST BR 1/8 Z	Angle, 45°	R 1/8	11	Steel, galvanized	350	5 080	1 200	2.65
251-14040-2	HYDRAULIC LUBR.FITT. ST CR 1/8 Z	Angle, 90°	R 1/8	11	Steel, galvanized	350	5 080	1 200	2.65
251-14044-8	HYDRAULIC LUBR.FITT. ST CR 1/4 Z	Angle, 90°	R 1/4	14	Steel, galvanized	350	5 080	1 200	2.65
Stainless steel									
251-14073-9	HYDR.LUBR.FITT.+CHECK VALVE A2 1/8	Straight	R 1/8	11	Stainless steel	400	5 800	800	1.76
251-14109-2	HYDRAULIC LUBR.FITT. A2 AR 1/8 Z	Straight	R 1/8	11	Stainless steel	350	5 080	600	1.32
251-10309-1	HYDRAULIC LUBR.FITT. A2 AR 1/4 Z	Straight	R 1/4	14	Stainless steel	350	5 080	1 200	2.65
251-10780-2	HYDRAULIC LUBR.FITT. A2 AM 10X1,0Z	Straight	M10x1	11	Stainless steel	350	5 080	500	1.10
251-14063-4	HYDRAULIC LUBR.FITT. A2 BR 1/8 Z	Angle, 45°	R 1/8	11	Stainless steel	350	5 080	1 200	2.65
251-14063-9	HYDRAULIC LUBR.FITT. A2 CR 1/8 Z	Angle, 90°	R 1/8	11	Stainless steel	350	5 080	1 200	2.65

Button-head grease nipples according DIN 3404

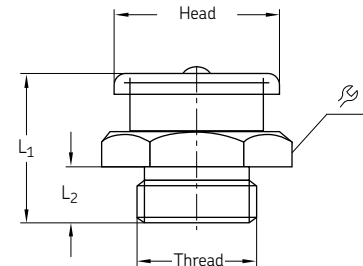

Order number	Designation	Head Ø	Thread	Material	Operating pressure max.		Weight (100 pcs)		
					bar	psi	g	lb	
mm									
251-14040-5	BUTTON HEAD LUBR.FITT.ST AG 1/8-16Z	16	G 1/8	17	Steel, galvanized	350	5 800	1 700	3.75
251-14040-4	BUTTON HEAD LUBR.FITT.ST AG 1/4-16Z	16	G 1/4	17	Steel, galvanized	350	5 800	1 900	4.19
251-10309-2	BUTTON HEAD LUBR.FITT.ST AG 3/8-16Z	16	G 3/8	17	Steel, galvanized	350	5 800	2 000	4.41
251-14063-1	BUTTON HEAD LUBR.FITT.ST AG 1/4-22Z	22	G 1/4	22	Steel, galvanized	350	5 800	4 000	8.82
251-14040-3	BUTTON HEAD LUBR.FITT.ST AG 3/8-22Z	22	G 3/8	22	Steel, galvanized	350	5 800	4 000	8.82
251-14045-8	BUTTON HEAD LUBR.FITT.ST AM10X1,0-16Z	16	M10x1	22	Steel, galvanized	350	5 800	1 700	3.75

Lubricating nipples

Lubrication fitting block

532-32248-1

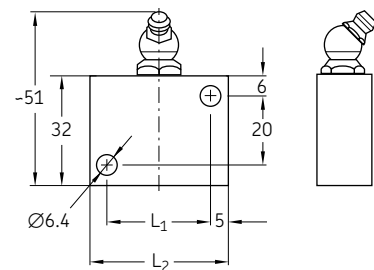

532-32454-1

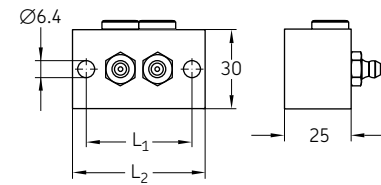

Order number	Designation	Ports for lubricating nipples	L ₁	L ₂	Material	Operating pressure max.		Weight (100 pcs)	
			mm	mm		bar	psi	g	lb
532-32248-1	LUBR.FITT.BLOCK W.1 FITT. R1/8 45 DEGREE	1	30	40	Steel, galvanized	400	5 800	160	0.35
504-37184-2	LUBR.FITT.BLOCK W.1 FITT. R1/4" 90 DEGREE	1	30	40	Steel, galvanized	400	5 800	217	0.48
504-37210-1	LUBR.FITT.BLOCK 2 FITT. R1/8	2	40	50	Steel, galvanized	400	5 800	132	0.29
504-37211-1	LUBR.FITT.BLOCK 3 FITT. R1/8	3	60	70	Steel, galvanized	400	5 800	177	0.39
532-32454-1	LUBR.FITT.BLOCK W. 2 FITT. R1/8	2	40	50	Steel, galvanized	400	5 800	331	0.73
432-70024-1	LUBR.FITT.BLOCK 2 CONN.R1/8 HORIZ./VERTIC	2 ¹⁾	40	50	Steel, galvanized	400	5 800	236	0.52

¹⁾ 2 lubricating nipple connections; corresponding tapered grease nipple order no. 251-14045-1

Holder with lubricating nipple and fitting

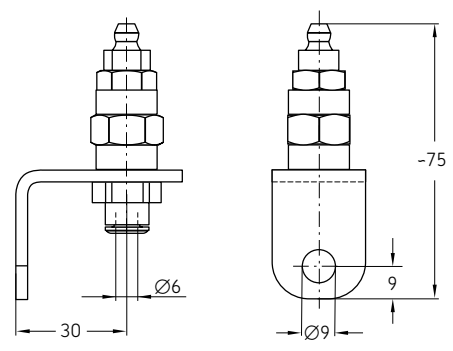

Order number	Designation	Ports for lubricating nipples	L ₁	Material	Operating pressure max.		Weight (100 pcs)	
			mm		bar	psi	g	lb
532-32131-1	HOLDER W.HYDR.LUBR.FITTING	1	40	Steel, galvanized	400	5 800	93	0.21

Lubricating nipples

Lubrication nipple manifolds

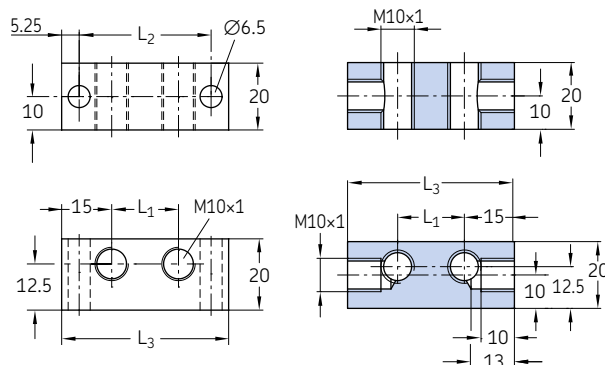

Order number	Designation	L ₁	L ₂	L ₃	Number of threaded holes	Material	Operating pressure max.		Weight (100 pcs)	
							bar	psi	g	lb
871-340-006	MANIFOLD 1XM10x1	–	19,5	30	1	Steel, galvanized	400	5 800	72	0.16
871-340-008 ¹⁾	MANIFOLD (2)XM10x1	–	19,5	30	1	Steel, galvanized	400	5 800	70	0.15
871-360-006	MANIFOLD 2XM10x1	20	39,5	50	2	Steel, galvanized	400	5 800	120	0.26
871-360-008 ¹⁾	MANIFOLD (4)XM10x1	20	39,5	50	2	Steel, galvanized	400	5 800	120	0.26
871-380-006	MANIFOLD VA 3XM10x1	40	59,5	70	3	Steel, galvanized	400	5 800	180	0.40
871-390-020	MANIFOLD 10XM10x1	20	199,5	210	10	Steel, galvanized	400	5 800	530	1.17
871-390-023	MANIFOLD 13XM10x1	20	200	270	13	Steel, galvanized	400	5 800	685	1.51

¹⁾ Nipple connection; corresponding tapered grease nipple with valve, order no. 996-001-890

Lubricating nipple box

Thread	Type	Quantity
M6x1	straight	30
M8x1	straight	20
M10x1	straight	10
G 1/8	straight	10
M6x1	45°	5
M8x1	45°	10
M10x1	45°	5
G 1/8	45°	5
M6x1	90°	5
M8x1	90°	10
M10x1	90°	5
G 1/8	90°	5



Order number	Designation	Material	Operating pressure max.	
			bar	psi
LAGN 120	LUBRICATION NIPPLE BOX LAGN 120	Steel, zinc plated, hardened and blue chromed	400	5 800



Description

These easy-to-service lubricant filters consist of a housing and an integrated screen. Grease filters have pressure ratings up to 400 bar (5800 psi) and allow flow rates up to 24 dm³/hour (6.3 US gal/hour), oil and fluid grease filters allow 2 l/min.

Galvanized and chromate-treated lubricant filter units are available with hydraulic lubrication fittings for lubrication pump reservoir filling. They are also suitable for upstream installation in lubrication systems with divider valves and for outlet connection with outside diameters of 6 mm.

Features and benefits

- Prevents system or component failures and extends system life to significant reduction of solids
- Economical, reliable and maintenance-friendly operation
- Compact and modular design mountable directly into pipes
- Wide range of volumetric flow levels and grades of filtration
- Optimized service handling by replacing of filter elements only
- Dirt monitoring of filter elements as an option
- Oil, fluid grease and grease filters

Applications

- General mechanic and plant engineering
- Ship building and offshore industry
- Pulp and paper industry
- Heavy industry

Screen filters for oil and fluid grease

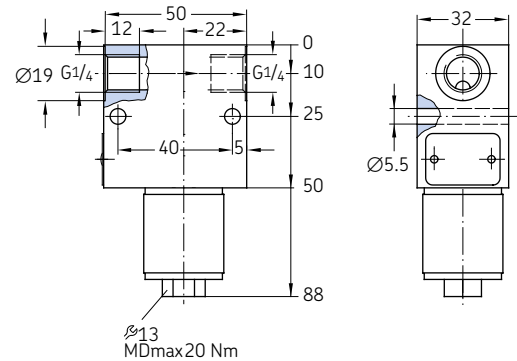

Order number	Designation	Lubricant	Filter rating µm	Connection thread	Material	Operating pressure max.		Weight	
						bar	psi	kg	lb
213-870	FILTER	FLUID GREASE NLGI CLASS 000, 00 63		G 1/4	Aluminum	60	870	0,31	0,68
213-870F*	FILTER	FLUID GREASE NLGI CLASS 000, 00 160		G 1/4	Aluminum	60	870	0,31	0,68
213-880	FILTER	OIL 25		G 1/4	Aluminum	60	870	0,31	0,68
213-930F	FILTER	FLUID GREASE NLGI CLASS 000, 00 160		G 1/4	Aluminum	60	870	1,27	2,80

Filter elements for oil and fluid grease filters

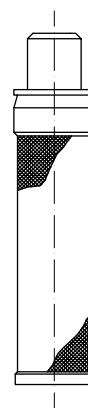

Order number	Designation	Lubricant	Filter rating µm	Operating pressure max.	
				bar	psi
213-870.U1	FILTER ELEMENT FOR 213-870	Fluid grease NLGI class 000, 00	63	60	870
213-870.U2	FILTER ELEMENT FOR 213-870F	Fluid grease NLGI class 000, 00	160	60	870
213-880.U1	FILTER ELEMENT FOR 213-880	Oil	25	60	870
213-870.U2	FILTER ELEMENT FOR 213-930F	Fluid grease NLGI class 000, 00	160	60	870

Screen filters for grease

628-36062-3

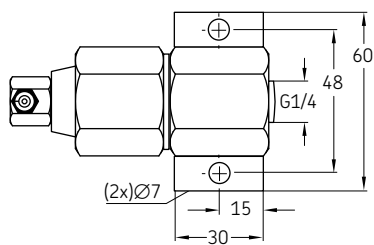

628-25531-2

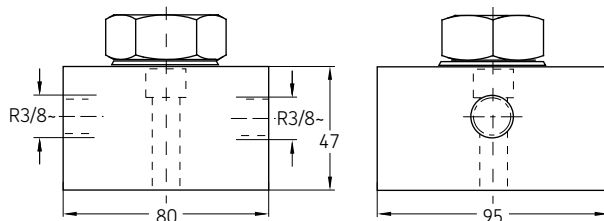

528-36045-6

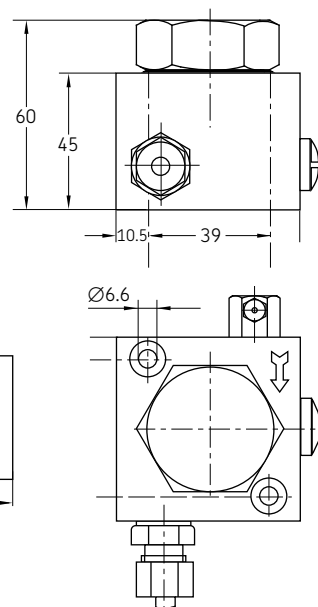

Order number	Designation	Tube ØD	Thread	Material	Operating pressure max.		Weight	
					bar	psi	g	lb
628-36062-3	Type SF 1-G 1/4 + 90° Nipple	-	G 1/4	Steel, galvanized	350	5 080	540	1.19
628-26452-2	Type SF 1-G 1/4	-	G 1/4	Steel, galvanized	350	5 080	440	0.97
428-21544-1	Coarse strainer (replacement part)	-	-	Steel, galvanized	350	5 080	2	0.005
528-36045-6	Filter unit with nipple and tube connection	6	-	Steel, galvanized	350	5 080	1 400	3.09
528-31341-3	Filter unit G 1/4 female	-	G 1/4	Steel, galvanized	350	5 080	1 280	2.82
628-25531-2	Filter unit G 3/8 female	-	G 3/8	Steel, galvanized	350	5 080	2 470	5.45

Filter elements for grease filter units

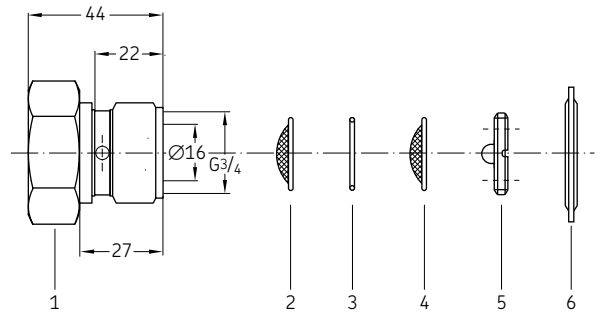

Order number	Designation	Item number	Material	Operating pressure max.		Weight	
				bar	psi	g	lb
428-21543-2	Hollow screw	1	Steel, galvanized	350	5 080	284	0.63
428-21544-1	Coarse strainer, fineness of filtration 410 µm	2	Brass	350	5 080	2	0.005
428-21546-2	Spacing ring	3	Spring steel	350	5 080	2	0.005
428-21545-1	Fine strainer, fineness of filtration 270 µm	4	Brass	350	5 080	2	0.005
303-17546-1	Threaded ring	5	Steel	350	5 080	12	0.03
220-12238-3	Usit sealing ring	6	NBR	350	5 080	7	0.02

Brushes



Description

Brush applicators are an easy, inexpensive and reliable solution for many lubrication applications. By using brush chain lubrication, the entire conveyor chain is lubricated, not just the joints of the chain links. Standard lubricating oil can be applied with brushes as highly viscous chain oil, but also fluid grease.

Features and benefits

- Lubrication with a brush for chain speeds up to 6 m / min
- Switching off and on individual chain lubrication systems possible
- Accurate dosage, regardless of oil viscosity and flow resistance
- High working pressure of the lubrication metering device enables targeted oil emissions
- Lubrication without the addition of costly compressed air

Applications

- Ovens, boilers, dryers
- Freezers
- Conveyors for sorting, cleaning, cooking and pasteurizing fruits and vegetables
- Dryers, smokers and conveyors for meat processing
- Conveyors for material transport

Brushes

UC, 233, 068874

UC-1066-10

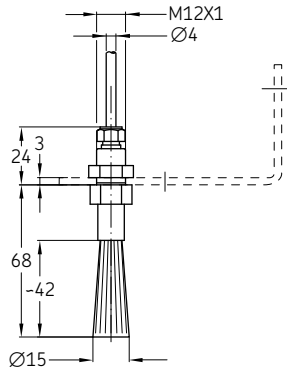

UC-1066-14

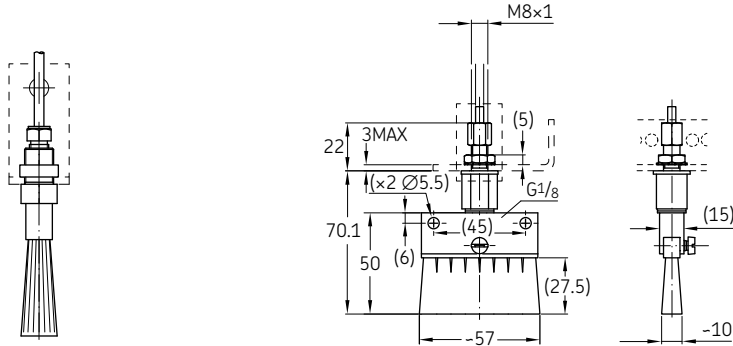

Order number	Designation	Shape	Tube ØD	Shape size	Temperature		Material	Fixation Weight		
					°C	°F		mm	g	lb
UC-1066-01	OIL BRUSH BRISTLE, 55X16	Rectangle	4 mm	55x16	10 to 60	50 to 140	Bristle	Ø8,5	110	0.24
UC-1066-02	OIL BRUSH MS, 55X16	Rectangle	4 mm	55x16	10 to 200	50 to 392	Brass	Ø8,5	160	0.35
UC-1066-03	OIL BRUSH BRISTLE, D30	Circle	4 mm	Ø30	10 to 60	50 to 140	Bristle	Ø19	85	0.19
UC-1066-04	OIL BRUSH BRISTLE, D15	Circle	4 mm	Ø15	10 to 60	50 to 140	Bristle	Ø12,5	45	0.10
UC-1066-05	OIL BRUSH PA6, D15	Circle	4 mm	Ø15	10 to 80	50 to 176	Polyamide 6.6	Ø12,5	45	0.10
UC-1066-06	OIL BRUSH PA6, 55X16	Rectangle	4 mm	55x16	10 to 80	50 to 176	Polyamide 6.6	Ø12,5	45	0.10
UC-1066-10	OIL BRUSH MS, D15	Circle	4 mm	Ø15	10 to 200	50 to 392	Brass	-	59	0.13
UC-1066-14	OIL BRUSH MS, 55X16	Rectangle	4 mm	55x16	10 to 300	50 to 572	Brass	-	-	-
233-14419-1	OIL BRUSH BZ MODEL SPF 57 G 1/8	Rectangle	G 1/8	55x16	10 to 200	50 to 392	Brass	2xØ5,5	62	0.14
233-13651-1	OIL BRUSH MS L=CA 47MM R1/8	Circle	R 1/8	Ø30	10 to 200	50 to 392	Brass	Ø20	20	0.04
233-13651-6	OIL BRUSH V2A MODEL SPR16/30/53 G 1/8	Circle	G 1/8	Ø30	10 to 200	50 to 392	Stainless steel	Ø20	35	0.08
068874	BRUSH	Circle	1/8 NPT	Ø15	10 to 80	50 to 176	Nylon	Ø20	20	0.04

Support for brushes

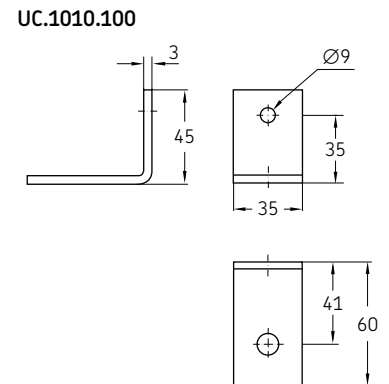
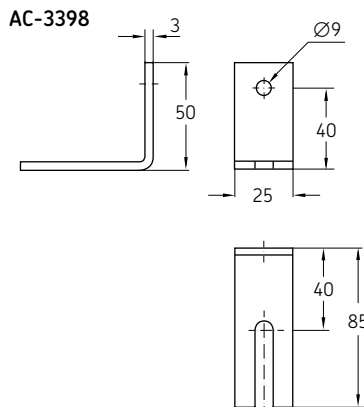
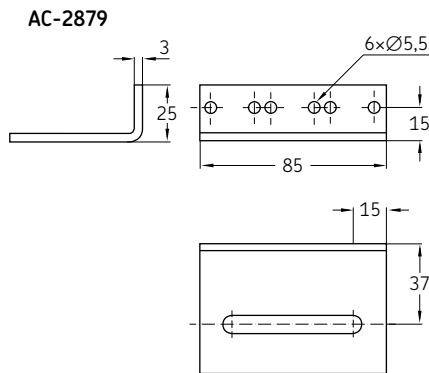

Order number	Designation	Suitable for brush	Temperature		Material
			°C	°F	
AC-2879	SUPPRT FOR BRUSH	UC-1066-01, -02, -06, -14	10 to 80	50 to 176	Steel
AC-3398	SUPPRT FOR BRUSH	UC-1066-04, -05, -10	10 to 80	50 to 176	Steel
UC.1010.100	SUPPRT FOR BRUSH	UC-1066-03	10 to 80	50 to 176	Steel



Description

The tools shown in the following chapter considerably improve and professionalize assembly, maintenance and testing work on lubrication systems.

- Hand-operated bending tools are available for bending steel pipes in the outer diameters of 4, 6, 8, 10 mm; machine-operated bending devices should be used for larger diameters or quantities
- Claw groove tool can be used to cut the metal pipe to length in one step and to produce the exact geometric shape of the claw groove; a claw groove is necessary for the three O-ring connection fittings
- The hand lever grease gun can be optimally used for functional testing and pressure testing of small central lubrication systems (preferably progressive systems) and progressive metering devices; it is equipped with:
 - High-pressure hose 1 m long
 - Glycerine damped manometer 0–400 bar, 63 mm diameter
 - Union nut and cutting ring for connection to cutting ring fittings for pipe \varnothing 6 mm

Features and benefits

- Simple and proven design for use with all lubrication systems
- Manual tools, no additional energy source required
- Professional tools to achieve the right quality result

Applications

- Lubrication system installation
- Lubrication system starting up
- Lubrication system maintenance

Pipe cutter



Description

This manual pipe cutter is particularly suitable for pipes made of copper, brass, light metal and hard plastic, as well as for steel and stainless steel pipes with outside diameters from 3 to 35 mm and a maximum cutting depth of 2.5 mm.

Features and benefits

- Optimal hold of the tube when cutting with two guide rollers
- Combines accuracy with ease of use
- Optimal size, light weight

Applications

- Metal and plastic forming machinery
- Construction machinery
- Agriculture, automation
- Printing

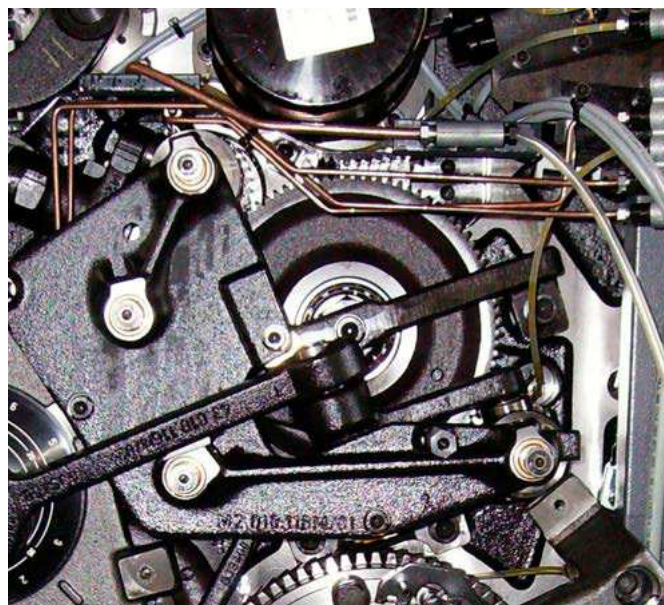

Technical data

Function	manual tube cutter
Material	steel, metal, plastic
Dimensions	145 x 58 x 45 mm 5.70 x 2.28 x 1.77 in

Order information

Order number	Designation	Tube		Weight	
		Ø mm	g	lb	
223-10540-1	STEEL PIPE CUTTER	3 - 35	356	0.78	
223-10540-2	CUTTING COG SR153	3 - 35	6	0.01	

Tools

Claw groove tool



Description

Manual claw groove tool suitable for hardened copper, brass, steel and stainless steel tubes with diameters of 4, 6, 8 and 10 mm. It allows the creation of claw grooves on metal pipes that are needed for use with SKF quick connectors.

Features and benefits

- One compact tool for both cutting and grooving
- Combines accuracy with ease of use
- Optimal size, light weight

Applications

- Metal and plastic forming machinery
- Construction machinery
- Agriculture, automation
- Printing

Technical data

Function	manual claw groove tool
Material	steel, metal, plastic
Dimensions	154 x 50 x 50 mm 6.06 x 1.96 x 1.96 in

Order information

Order number	Designation	Tube	Weight	
			Ø mm	g
169-000-336	Pipe cutter 4 mm	4	345	0.76
169-000-337	Pipe cutter 6 mm	6	344	0.76
169-000-338	Pipe cutter 8 mm	8	349	0.77
844-330-006	Cutting ring 4 mm	4	20	0.044
844-330-007	Cutting ring 6 mm	6	21	0.046
844-330-007	Cutting ring 8 mm	8	20	0.044

Claw groove information

Tube	A	B	C
Ø mm	mm	mm	mm
4	3,1	5	0,3 ... 0,7
6	4,9	6,2	0,4 ... 0,9
8	6,9	6,2	0,5 ... 0,9

Claw grooves

For the use of SKF quick connector fittings a claw groove is required at the end of the pipe.

1) Tolerances of ±0,3 mm have to be regarded.
2) Tolerances of ±0,2 mm to be regarded.

Tube bender



Description

The easy-to-use manual tube bender is designed for pipe diameters of 6, 8 and 10 mm and a bending radius range from 1-180° with a visible, marked scale featuring 15° steps. The bender is suitable for use with hardened copper, steel and stainless steel tubes.

Features and benefits

- Designed for bending hardened copper, steel and stainless steel
- Provides measurements in inches and millimeters
- Combines accuracy with ease of use
- Optimal size, light weight
- Includes oil-absorbing shoe

Applications

- Metal and plastic forming machinery
- Construction machinery
- Textile machinery
- Agriculture
- Automation
- Printing

Technical data

Function	manual tube bender
Material	steel, metal, plastic
Bending radius	1-180°
Scale	15° steps
Length	260-370 mm 10.23-14.56 in

Order information

Order number	Designation	Tube	Weight	
			kg	lb
		Ø mm		
223-13700-8	Tube bender	6	0,7	1.54
223-13700-9	Tube bender	8	1,3	2.86
223-13700-7	Tube bender	10	1,18	2.60

Tube bending fix



Description

Designed for installation on a workbench, the manual tube bending fix is suitable for hardened copper, steel and stainless steel tubes with diameters of 4, 6, 8 and 10 mm. Its bending radius range is 1-180°.

Features and benefits

- One compact tool for workbench assembly with exchangeable bending disks
- Combines accuracy with ease of use
- Optimal size, light weight

Applications

- Metal and plastic forming machinery
- Construction machinery
- Textile machinery
- Agriculture
- Automation
- Printing

Technical data

Function	manual tube bending fix
Material	steel, metal, plastic
Bending radius	1-270°

Order information

Order number	Designation	Tube Ø mm	Weight	
			kg	lb
248-803.20	Tube bending fix	4, 6, 8, 10	1,53	3.37
248-803.17	Bending disk	12 (special grooved disk) ¹⁾	0,378	0.83
248-803.16	Bending disk	4 (retro fitting set) ²⁾	0,093	0.21

¹⁾ To bend pipes with 12 mm diameter, the special grooved disk 248-803.17 must be ordered in addition to pipe bending device 248-803.20.

²⁾ Retro fitting set with grooved disk for older pipe bending devices 248-803.20.

Hose cutter



Description

This manual hose cutter is particularly suitable for tubes and hoses made of plastic and rubber, including tubes with thin metal layers. It cuts tubes with outside diameters up to 12,5 mm.

Features and benefits

- Combines accuracy with ease of use
- Highly resistant against stress and flexural vibrations
- Small size, light weight

Applications

- Metal and plastic forming machinery
- Construction machinery
- General industry
- Agriculture
- Printing

Technical data

Function	manual hose cutter
Material	steel, metal
Dimensions	175 × 115 × 10 mm 6.88 × 4.52 × 0.39 in

Order information

Order number	Designation	Tube
		Ø mm
226-12508-5	HOSE CUTTER	1-12,5
226-13095-7	HOSE CUTTER REPLACEMENT BLADES	1-12,5

Tools

Grease pump set for pressure and function check



Description

This manual grease pump set for pressure and function check is a perfect tool for lubrication system installation, maintenance or troubleshooting existing systems. Its integrated pressure gauge, hose and fitting enable accurate system function check and help to identify system leaks as well as system blockages. The set includes two different connection options: a hydraulic coupler for grease nipple, and a fitting for connection of tube $\varnothing 6$ mm.

Features and benefits

- Combines accuracy with ease of use
- Set contains a wide range of fittings
- Robust and reliable tool
- Small size, light weight

Applications

- Metal and plastic forming machinery
- Construction machinery
- General industry
- Agriculture
- Printing



Technical data

Function	grease pump set for pressure and function check
Connections	hydraulic coupler for grease nipple, or fitting for connection of tube $\varnothing 6$ mm
Material	steel, metal

Order information

Order number	Designation
--------------	-------------

604-36879-1	PRESSURE AND FUNCTION TESTING SET
-------------	-----------------------------------

Drum plug wrench



Description

The drum plug wrench was developed to simplify the opening and closing of caps and plugs on liquid drums. The model 5841 wrench eliminates the need for cumbersome makeshift tools, such as screwdrivers and hammers. Constructed of safe, non-sparking cast aluminum, the drum plug wrench features a comfortable, textured grip. This cost-effective wrench is suitable for agriculture, construction, industrial, fleet maintenance and vehicle service applications – anywhere that liquid drums are used. It is compatible with standard metal and plastic caps or plugs on 60 l (16 gal) and 200 l (55 gal) drums.

Features and benefits

- Suitable for common cap types – both plastic and metal
- Non-sparking, non-corrosive aluminum construction
- Saves time and effort when loosening and tightening plugs and caps
- Fits large and small caps
- Cost-effective solution
- Simple to use

Applications

- Caps or plugs on 60 l (16 gal) and 200 l (55 gal) drums

Technical data

Function	drum plug wrench
Application	60 l (16 gal) and 200 l (55 gal) drums
Material	aluminum
Wrench	3/4

Order information

Order number	Designation
5841	DRUM PLUG WRENCH

Socket wrench insert for elbows



Description

This socket wrench insert for elbow fitting mounting allows quick and clean system installation work, especially in machines or in facilities where lubrication lines have to run around many corners and barriers.

Features and benefits

- Combines accuracy with ease of use
- Highly resistant against stress and flexural vibrations
- Small size, light weight

Applications

- Metal and plastic forming machinery
- Construction machinery
- General industry
- Agriculture
- Printing

Technical data

Function	socket wrench insert
Application	elbows with max. width of 11 mm
Material	tool steel
Wrench	1/4
Dimensions	Ø24 mm, height 20 mm

Order information

Order number Designation

917-877 SOCKET WRENCH INSERT FOR ELBOWS

Mounting stud for hose couplings



Description

The mounting stud is an important assembly tool for the self-assembly of threaded joints of high pressure hoses. With the aid of the stud it is possible to mount the threaded sleeve correctly, neither too far nor too little into the high-pressure hose. That is important because not correctly mounted sleeves, can cause hose burst or not sealing hose couplings.

Features and benefits

- Simple mounting without complex measuring with caliper
- Avoiding of malfunctions in the central lubrication system due to blocked or burst hose lines
- Avoiding of errors during hose assembly

Applications

- Hose mounting for nominal diameter 6 mm

Technical data

Function	mounting stud
Hose type	ND 6 mm
Immersion depth	11 mm
Material	galvanized steel
Weight	20 g; 0.05 lbs
Dimensions	Ø10 mm, Ø6 mm, 40 mm

Order information

Order number Designation

432-23077-1 MOUNTING STUD

Refill pumps



Description

Filling pumps make it easier to top up lubricants in reservoirs of automatic lubrication pumps. By using original barrels, hoses and couplings, it is ensured that no dirt gets into the reservoir during the filling process. Contaminated lubricants that enter the reservoir during manual filling via the open reservoir lid are the greatest risk of malfunctions in a centralized lubrication system.

Depending on the desired degree of automation, the filling pumps can be supplied with manual, compressed air or electric drive.

For longer transport distances, the use of a filling pump on a trolley is recommended.

Features and benefits

- Improved maintenance of all lubrication systems
- Easy-to-use, application-optimized product design
- Quick and professional refilling with contamination prevention, compared to manual grease refilling
- Optimized consumption of refilling barrel lubricants due to use of perfectly suited barrel follower plates
- Wide range of filling pumps for all common reservoir sizes

Applications

- General mechanic and plant engineering
- Agriculture and forestry industry
- Construction machinery
- Pulp and paper industry
- Renewables industry
- Oil and gas industry
- On-road vehicles
- Heavy industry
- Etc.

Powerluber



Description

The Lincoln model 1886 battery-powered grease gun offers the key features you need for tough jobs – nothing more and nothing less. The versatility of the two-speed design enables you to address all lubrication points with a single tool, protecting equipment and machinery from costly repair and downtime. The tool's high-ratio gearing will move large quantities of grease quickly when needed, while its low gearing supports deliveries of up to 690 bar.

Also, the tool has a convenient, built-in LED to illuminate the work area and a three-point stance to keep the tool upright.

Features and benefits

- Flex hose that comes with anti-kink spring guards on each end and is the ideal size for most lubrication tasks
- Integrated vent valve purges trapped air to help assure easy prime
- The filler nipple facilitates a quick, clean refill for those who prefer to bulk fill their barrel
- Lithium-ion technology is powerful and efficient, delivering an even flow of energy
- Display shows battery charge and grease output in both grams and ounces

Applications

- General mechanic and plant engineering
- Agriculture, construction, automotive, trucking
- Heavy equipment
- Wind energy
- General industry

Technical data

Function	battery-operated grease gun
Operating power	20 V
Operating pressure	max. 690 bar; 10 000 psi
Delivery rate	max. 284 g/min; 10 oz/min
Reservoir capacity	411 g; 14.5 oz
Operating temperature	-18 to 50 °C; 0 to 122 °F
Rated current	5.0 A
Lubricant	grease up to NLGI 2
Material	steel, metal, plastic

Order information

Order number	Designation	Approval	Weight	
			kg	lb
1886	Single battery unit with charger	UL	3,4	7,5
1886-E	Single battery unit with charger	CE	3,4	7,5
1871	20V Li-ion battery, 2,5 Ah	UL, CE	-	-
1872	20V Li-ion battery, 4,0 Ah	UL, CE	-	-

Manual grease filler guns



Description

The manual cartridge grease gun is ideal for agricultural, industrial and construction industries and for private use. It can be utilized to lubricate directly or as filler pump for automatic lubrication systems. The tool is designed for rough treatment on the job with a cast iron pump head, precision fit plunger and extra heavy follower spring.

Features and benefits

- For use with cartridges and bulk grease
- Knurled body for firm and safe grip
- High-output setting delivers twice the grease per stroke
- High or low pressure for light- or heavy-duty greasing action
- Extension swivels 360° for hard-to-reach fittings
- Plated barrel, head and handle

Applications

- General mechanic and plant engineering
- Agriculture, construction, automotive, trucking
- Heavy equipment
- Wind energy
- General industry

Technical data

Function	manually operated cartridge grease gun
Delivery rate	max. 284 g/min; 10 oz/min
Cartridge capacity	420 ml; 14.2 fl oz
Operating temperature	-18 to 50 °C; 0 to 122 °F
Lubricant	grease up to NLGI 2
Material	steel, metal, plastic

Order information

Order number	Designation	Operation pressure max.		Weight	
		bar	psi	kg	lb
001013	LEVER GUN	275	4 000	2,09	4.61
001142	LEVER GUN	400	5 800	1,85	4.08
001133	PISTOL GUN	414	6 000	1,62	3.57

Refill pumps

Filler cylinder



Description

Lubricant outlets of automatic lubrication system pumps can, as an option, be equipped with one suitable filler socket in order to fill the unit using a filling cylinder (cartridge). A filler cylinder is only recommended for systems with low lubricant consumption and reservoir sizes up to 2 kg.

Features and benefits

- Robust and sustainable manual filler pump
- Knurled body for firm and safe grip
- Easy to use

Applications

- General mechanic and plant engineering
- Agriculture, construction, automotive, trucking
- General industry
- Heavy equipment
- Wind energy

Technical data

Function	manually operated cartridge filler cylinder
Reservoir capacity	420 ml; 14.2 fl oz
Operating temperature	-18 to 50 °C; 0 to 122 °F
Lubricant	grease up to NLGI 2
Material	steel, metal, plastic

Order information

Order number	Designation	Thread
		mm
169-000-171	Filler cylinder	–
169-000-174	Filler coupling	M20x1,5
5590-00000002	Filler coupling	M22x1,5

Manually and pneumatically operated filling pumps 169



Description

The manual or pneumatically topping pump 169-... is suitable for barrels sizes of 15, 20, 25 and 50 kg. It is available as stationary and mobile version as well as manually or pneumatically operated.

Features and benefits

- Easy and cost-efficient filling of pump reservoirs
- No contamination of the lubricant during the filling process
- Steel pump with guided grease follower piston
- Centring cover, which positions the pump centrally in the barrel and ensures optimum residual emptying

Applications

- Construction machinery
- Agriculture vehicles
- Production plants

Technical data

Function	manually operated filling pump
Design	manually operated filling pump
Delivery rate	max. 100 g/stroke; 10 oz/stroke
Design	pneumatically operated filling pump
Delivery rate	max. 1 800 g/min; 3.97 lbs/min
Ratio	1 : 3
Operation pressure	max. 24 bar; max. 348 psi
Air pressure	max. 8 bar; max. max. 116 psi
Barrel capacities	15, 20, 25 and 50 kg
Operating temperature	-10 to +40 °C; 14 to 104 °F
Lubricant	fluid grease and grease up to NLGI 2
Coupling	acc. to ISO 241 B DN6 R 1/4
Hose length	2 m; 6.5 ft
Material	steel, metal, plastic
Dimensions	max. 550 x 550 x 950 max. 21.65 x 21.65 x 37.4

Order number	Designation	Drum	Inner diameter		Medium	Delivery rate per stroke		Dimensions D x H		Weight	
			kg	mm		in	cm ³	in ³	mm	mm	kg
169-000-004	MANUAL FILLING PUMP 15L,STATIONARY	15	267	10.5	NLGI 1/2	4	0.25	360x640	14,2x25,2	4,383	9.66
169-000-012	MANUAL FILLING PUMP 10L,STATIONARY	10	236	9.3	NLGI 1/2	25	1.53	280x610	11x24	4,68	10.32
169-000-016	MANUAL FILLING PUMP 20L,STATIONARY	20	290	11.4	NLGI 1/2	25	1.53	300x590	11,8x23,2	5,12	11.30
169-000-082	MANUAL FILLING PUMP 25/50L,MOBILE	25/50	350 ¹⁾	13.8 ¹⁾	00/000	100	6.1	350x800	23,2x31,5	7	15.43
169-000-084	MANUAL FILLING PUMP 25L,STATIONARY	25	350 ¹⁾	13.8 ¹⁾	00/000	250	15.3	320x630	12,6x24,8	4	8.82
169-000-042	MANUAL FILLING PUMP 25L,MOBILE	25	300-335	11.2-13.2	NLGI 1/2	45	2.7	550x780	21,7x30,7	16,8	37.04
169-000-054	MANUAL FILLING PUMP 50L,MOBILE	50	355-387	14-15.2	NLGI 1/2	45	2.7	550x950	21,7x37,4	10	22.05
169-000-342	MANUAL FILLING PUMP 25L,STATIONARY	25	300-335	11.2-13.2	NLGI 1/2	45	2.7	340x700	13,4x27,6	6,38	14.06

¹⁾ max. outer diameter

Electrically operated filling pump EFP



Description

The EFP electric grease feeding pump is a piston pump for grease drum sizes from 16 to 25 kg. The delivery stroke is generated at the lower end of the intake tube by a delivery piston that is controlled by an electrically driven eccentric shaft. The pump is activated using an ON/OFF switch attached to the terminal box.

Features and benefits

- Suitable for pressures up to 250 bar
- Suitable for oil, fluid grease, and grease
- Integrated automatic shut-off function for use with grease guns

Applications

- Wind energy
- Stationary and vehicles

Order information

Order number	Designation	Weight	
		kg	lb
24-1560-3577	El. barrel pump EFP	34,5	76.07
24-1560-3578	El. barrel pump EFP with signal input	34,9	76.95
24-1868-4334	High-pressure hose, max. 275 bar, 5 m	–	–
412-423W	Screw union G1/4 412-423W	–	–
995-001-500	Coupling socket G1/4	–	–
995-000-705	Coupler plug G1/4	–	–
169-000-031	Grease gun	–	–

Technical data

Function	electrically operated piston pump
Delivery rate	max. 400 cm ³ /min; 24 in ³ /min
Barrel capacities	16 and 25 kg
Operating temperature	-10 to +60 °C; 14 to 140 °F
Lubricant	oil, fluid grease and grease up to NLGI 2
Outlet fitting	G 1/4
Automatic shut-off, fixed	250 bar
Pressure regulating valve, fixed	300 bar
Restart after pressure relief	< 150 bar
Material	steel, metal, plastic
System voltage	230 V AC/50 to 60 Hz
Motor power	370 W
Protection class	IP54
Insulation class	F
Intake current	2,73 A
Electrical connection	grounded plug, 3 m cable - motor protection via circuit breaker
Dimensions (pump only)	550 x 900 mm; 21.7 x 35.4 in

Accessories for EFP

Order number	Designation	Suitable drum sizes	Weight	
			kg	lb
24-1722-2545	Carrying frame	16/25	13,2	29.11
24-1722-2551	Carrying frame with handle and wheels	16/25	16,6	36.60
24-1722-2552	Carrying frame with wheels	16/25	15	33.08
24-1952-2034	Follower plate Ø 265-285	16/25	0,7	1.54
24-1952-2035	Follower plate Ø 285-305	16/25	1	2.21
24-1952-2036	Follower plate Ø 305-350	16/25	1,5	3.31

Cross reference list

Historical order number	SKF Lincoln order number	Historical order number	SKF Lincoln order number
226-12490-3	898-610-000	408-416	223-12368-6
226-12557-1	941-206-108	408-423W	223-12270-9
226-12557-2	941-209-104	408-423W-S3	223-13614-9
226-12557-3	941-212-101	408-425	223-12362-4
226-12557-4	941-215-104	410-301	223-12295-8
226-12557-6	941-220-104	410-302	223-13032-6
226-12557-7	941-210-104	410-323	223-14304-2
226-13095-1	898-710-001	410-403	223-14129-4
226-13095-6	179-990-186	410-403W	223-12272-9
401-013-111	222-12599-9	410-403W-S3	223-14420-7
401-016-132	222-12521-2	410-404	223-12483-8
401-016-171	222-13678-1	410-405W	223-13048-5
401-016-191	222-12578-5	410-407	223-13057-5
401-021-111	222-13678-4	410-409	223-12409-9
404-301	223-14083-3	410-410	223-12531-2
404-302	223-13032-1	410-410-S3	223-13615-6
404-403	223-13069-1	410-411	223-13028-2
404-403W	223-12270-8	410-413W	223-14214-4
404-404	223-12531-8	410-416	223-12368-8
404-405W	223-13021-4	410-425	223-12485-2
404-406-S3	223-13615-5	410-433W	223-10313-7
404-413	223-12271-8	410-443-S3	223-14420-4
404-425	223-13069-2	410-463	223-10313-2
406-301	223-12295-3	412-301	223-12296-1
406-302	223-12373-9	412-302	223-12373-2
406-302-S3	223-14082-5	412-403W	223-12360-8
406-303	223-14234-7	412-404	223-12280-9
406-323	223-13766-9	412-411	223-12481-8
406-331	223-12295-2	412-412	223-13732-8
406-332	223-12374-9	412-416	223-13698-4
406-332-S3	223-13638-2	412-423W	223-12477-9
406-333	223-14129-1	415-301	223-12296-9
406-403	223-10263-8	415-302	223-12374-8
406-403-S3	223-14184-5	415-403W	223-12361-9
406-403W	223-13016-3	415-405W	223-13021-7
406-403W-S3	223-13658-2	415-407	223-12563-2
406-404	223-12483-2	415-409	223-12409-8
406-405	223-12485-8	415-415	223-12531-6
406-405W	223-13048-1	415-415-S3	223-12454-8
406-406	223-12482-9	415-416	223-12564-2
406-407	223-12484-2	415-433W	223-13621-8
406-409	223-13050-4	418-301	223-12583-1
406-411	223-12481-4	418-302	223-12374-7
406-413	223-14129-4	418-403W	223-13766-1
406-413W	223-12477-1	418-403W-S3	223-14420-8
406-413W-S3	223-13614-7	418-416	223-12564-8
406-415W	223-12380-6	418-418	223-13732-4
406-416	223-12368-4	422-407	223-13057-4
406-423	223-12271-7	428-403W	223-13610-9
406-423-S3	223-13658-5	428-413W	223-14214-9
406-423W	223-12270-7	441-008-511	223-13021-1
406-423W-S3	223-13614-9	441-008-511-S3	223-13715-1
406-425	223-13021-3	441-110-163	223-13028-4
406-433	223-13023-1	441-112-162	223-12286-8
406-433-S3	223-13658-6	443-190-901	223-13050-3
406-435	223-13023-3	443-215-001	223-12562-2
406-435-S3	223-13677-2	443-306-341	223-14171-1
406-443	223-12533-9	443-308-351	223-14102-3
406-443-S3	223-13658-7	443-406-061	223-14190-6
406-445	223-13023-2	443-408-081	223-14190-7
406-445-S3	223-13677-4	443-410-101	223-13040-9
406-446	223-14181-3	443-412-121	223-13761-5
406-463W	223-13766-6	443-415-151	223-14190-5
408-301	223-12295-6	445-516-081	223-12284-7
408-302	223-13032-4	445-516-101	223-12369-9
408-403	223-12361-6	445-519-041	223-13629-1
408-403W	223-12477-6	445-519-061	223-12479-5
408-405	223-12362-8	445-521-122	223-13669-3
408-405W	223-14240-5	445-529-041	223-12480-2
408-407	223-12484-6	445-531-061	223-12369-7
408-408	223-12531-9	445-531-062	223-12480-7
408-408-S3	223-13615-3	445-808-351	223-13040-1
408-409	223-12409-6	445-810-371	223-14189-1
408-411	223-12481-6	460-706-001	223-10297-5
408-413W	223-10080-3	460-710-001	223-10297-6

Cross reference list

Historical order number	SKF Lincoln order number	Historical order number	SKF Lincoln order number
460-712-001	223-10297-9	96-3113-0058	222-13678-3
466-411-001	223-10530-4	96-3115-0060	223-14189-7
466-413-001	223-13702-7	96-3116-0058	222-12521-5
466-416-001	223-13702-1	96-3117-0058	222-12521-6
466-418-001	223-13702-6	96-3118-0058	222-12521-4
471-106-163	223-13655-1	96-3120-0058	222-12578-4
471-110-163	223-13655-7	96-3121-0058	222-12578-8
471-112-163	223-14268-4	96-3122-0058	222-12578-3
504-410	223-12542-2	96-3123-0058	222-12047-2
506-410	223-13705-5	96-3125-0058	222-12599-3
506-412	223-13622-3	96-3126-0058	222-12578-2
506-413	223-10986-1	96-3127-0058	222-12047-8
508-410	223-13024-4	96-3128-0058	222-12047-4
508-412	223-13622-7	96-3131-0058	222-12599-5
508-413	223-13024-8	96-3132-0058	222-13670-1
510-412	223-12542-7	96-3134-0058	222-12599-6
512-410	223-12452-8	96-3208-0060	223-10374-3
650-050	213-12505-1	96-3210-0060	223-14189-5
650-060	213-12168-8	96-3212-0060	223-14189-9
650-080	213-12505-3	96-3216-0060	223-14189-2
650-100	213-12505-2	96-3220-0060	223-14189-3
650-120	213-12505-5	96-5608-0058	223-13032-3
650-200	213-12505-8	96-5610-0058	223-12374-6
96-0203-0058	223-10814-2	96-5708-0058	223-12295-5
96-0204-0058	223-12477-8	96-5710-0058	223-12295-9
96-0222-0058	223-13016-2	96-5909-0058	223-13621-6
96-0223-0058	223-13749-3	96-6002-0058	223-12533-5
96-0308-0060	223-10889-2	96-6202-0058	223-12533-6
96-0319-0058	223-11242-5	96-6904-0058	223-12563-5
96-0328-0058	223-14214-8	96-7004-0058	223-13629-1
96-0408-0058	223-12483-5	96-7006-0058	223-12479-9
96-0506-0060	223-10307-2	96-7008-0058	223-12479-8
96-0510-0060	223-13033-2	96-7104-0158	223-12480-8
96-0518-0060	223-13693-9	96-7906-0058	223-12285-8
96-0706-0060	223-13693-4	96-7908-0058	223-12285-9
96-0708-0060	223-13693-6	96-7910-0058	223-12285-5
96-0710-0060	223-13693-2	96-7912-0058	223-12285-6
96-0711-0060	223-13693-1	96-7920-0058	223-12285-7
96-0722-0060	223-12273-2	96-8010-0058	223-13669-4
96-1108-0058	223-12477-2	96-8910-0058	223-13655-2
96-1109-0058	223-13016-6	96-8912-0058	223-13655-4
96-1110-0058	223-13016-4	99-0204-0058	223-13658-9
96-1111-0058	223-13016-9	99-0215-0058	223-13715-9
96-1112-0058	223-13016-7	99-0217-0058	223-13715-6
96-1113-0058	223-14129-3	99-0228-0058	223-14184-2
96-1116-0058	223-13621-1	99-2712-0058	223-13639-9
96-1117-0058	223-13749-5	99-5604-0058	223-13638-6
96-1120-0058	223-12359-6	99-5612-0058	223-14082-3
96-1121-0058	223-12360-6	99-5704-0058	223-13639-5
96-1214-0058	223-11242-4	DIN7513-BM5x10	206-12124-3
96-1508-0060	223-10670-3	DIN7513-BM6x16	206-12125-4
96-1511-0060	223-12582-5	DIN912-M4x12-A4	201-13741-1
96-1523-0060	223-14293-2	DIN912-M4x20-8.8	201-12015-5
96-1532-0060	223-14152-2	DIN912-M5x10-A2	201-13608-6
96-1533-0060	223-14293-4	DIN912-M6x16-8.8	201-12019-9
96-1545-0060	223-14293-8	DIN912-M6x25-8.8	201-12018-7
96-1555-0060	223-12581-9	DIN912-M6x60-8.8	201-12019-6
96-1610-0060	223-10688-1	DIN912-M8x16-8.8	201-12021-3
96-1611-0060	223-10187-1	DIN933-M10x40-8.8	200-12523-3
96-1612-0060	223-13054-4	DIN933-M5x12-8.8	200-13092-1
96-1622-0060	223-12287-8	DIN933-M6x16-8.8	200-13022-4
96-1623-0060	223-12288-2	DIN933-M6x20-8.8	200-13022-7
96-1643-0060	223-14293-1	DIN933-M6x25-8.8	200-13022-1
96-1651-0060	223-12577-8	DIN933-M8x20-8.8	200-12553-4
96-1653-0060	223-12577-2	DIN933-M8x25-8.8	200-10406-7
96-1654-0060	223-12580-2	DIN934-M5-8	207-12138-2
96-1656-0060	223-13759-7	DIN934-M6-8	207-12135-5
96-3101-0058	222-13678-2	DIN936-M14x1.5-5	207-12141-1
96-3102-0058	222-12599-2	DIN936-M16x1.5-5	207-12141-8
96-3105-0058	222-12578-9	DIN985-M12-6	207-12516-6
96-3106-0060	223-14189-6	DIN985-M3-6	207-12516-9
96-3109-0058	222-13678-8	DIN985-M8-6	207-12516-1
96-3110-0058	222-12521-8		
96-3111-0058	222-11053-1		
96-3112-0060	223-13785-8		

Index

24-1560-3577..... 167	96-1706-0058 62	105-35025-5 104	169-000-082 166
24-1560-3578..... 167	96-1806-0058 62	105-35134-1..... 104	169-000-084 166
24-1722-2545..... 167	96-1808-0058 62	105-35134-3..... 104	169-000-171..... 165
24-1722-2551..... 167	96-2106-0058 52	105-35134-4..... 104	169-000-174..... 165
24-1722-2552..... 167	96-2118-0058 52	105-35134-9..... 104	169-000-336 154
24-1868-4334 167	96-2122-0058 52	105-35183-3..... 104	169-000-337 154
24-1952-2034 167	96-3102-0058 78	105-35251-1..... 104	169-000-338 154
24-1952-2035 167	96-3106-0058 78	105-35251-3..... 104	169-000-342 166
24-1952-2036 167	96-3112-0058 78	105-35308-1 104	169-101-004..... 135
44-1755-2019..... 25	96-3118-0060 63	106-35203-1..... 105	169-101-607..... 136
44-1755-2029..... 75	96-3122-0060 63	106-35203-2 105	169-102-015..... 136
96-0335-0058..... 43	96-3129-0058 78	106-35203-3 105	169-102-020 135
96-0342-0058..... 43	96-3133-0058 78	106-35203-4 105	169-102-506 135
96-0508-0060..... 53	96-3136-0058 78	106-35203-7..... 105	169-104-008 135
96-0512-0060..... 53	96-3137-0058 78	106-35231-1..... 105	169-104-015..... 136
96-0606-0060..... 53	96-5911-0058 44	106-35231-2..... 105	169-104-020 135
96-0608-0060..... 53	96-5912-0058 44	106-35231-3..... 105	169-106-004 135
96-0712-0060..... 53	96-5913-0058 44	106-35231-6..... 105	169-106-011..... 136
96-0715-0060..... 53	96-6112-0058 51	106-35267-4..... 105	169-106-015..... 136
96-0718-0060..... 53	96-6304-0058 62	106-35292-1..... 105	169-106-020 135
96-0806-0058..... 62	96-6306-0058 62	106-35292-2..... 105	169-110-010..... 136
96-0808-0058..... 62	96-6308-0058 62	111-35114-1 114	169-110-015..... 136
96-0810-0058..... 62	96-6404-0058 62	111-35301-4..... 114	169-110-020 135
96-0818-0058..... 62	96-6406-0058 62	111-35306-5..... 103	169-116-000..... 135
96-0906-0058..... 62	96-6408-0058 62	112-35127-2..... 102	169-125-015..... 136
96-1114-0058..... 44	96-7108-0058 57	112-35127-5..... 102	169-125-020 135
96-1206-0058..... 43	96-7808-0058 57	112-35127-7..... 102	169-140-001..... 136
96-1214-0058..... 43	96-7812-0058 57	112-35225-4..... 102	169-200-008 34
96-1406-0060..... 59	96-7815-0058 57	113-35075-2..... 103	179-990-186..... 121
96-1408-0060..... 59	96-7818-0058 57	113-35075-3..... 103	200-10406-7 121
96-1410-0060..... 59	96-7822-0058 57	161-110-031+924..... 133	200-12007-6 121
96-1412-0058..... 51	96-7914-0058 58	161-120-064+924 133	200-12009-7 121
96-1541-0060..... 59	96-7916-0058 58	161-212-054..... 130	200-12399-2 121
96-1542-0060..... 59	96-8006-0058 57	161-600-036 132	200-12523-3 121
96-1543-0060..... 59	96-8008-0058 57	162-310-005 141	200-12553-4 121
96-1551-0060..... 59	96-8012-0058 57	169-000-004 166	200-12553-8 121
96-1556-0060..... 59	96-8014-0058 57	169-000-012 166	200-13017-5..... 121
96-1633-0060..... 59	96-8016-0058 57	169-000-016 166	200-13017-9..... 121
96-1642-0060..... 59	96-8804-0058 60	169-000-031 167	200-13022-1 121
96-1644-0060..... 59	96-8906-0058 60	169-000-042 166	200-13022-4 121
96-1652-0060..... 59	99-0222-0058 45	169-000-054 166	200-13022-7 121

Index

200-13037-3.....	121	222-12578-8.....	78	223-10540-2	153	223-12290-7.....	54
200-13092-1.....	121	222-12578-9.....	78	223-10550-1.....	48	223-12291-2.....	54
201-12015-5.....	121	222-12599-2.....	78	223-10550-2	48	223-12291-4.....	54
201-12018-7.....	121	222-12599-3	78	223-10550-6	48	223-12291-6.....	54
201-12019-6.....	121	222-12599-5.....	78	223-10550-8	48	223-12292-2.....	55
201-12019-9.....	121	222-12599-6.....	78	223-10563-5	48	223-12292-5.....	55
201-12021-3.....	121	222-12599-9.....	78	223-10563-6	48	223-12292-9.....	55
202-085-5	131	222-13618-1.....	78	223-10563-7	48	223-12295-2	41
202-175-30.....	127	222-13618-2.....	78	223-10563-8	48	223-12295-3	41
202-275-2.....	127	222-13618-3.....	78	223-10638-3	65	223-12295-5.....	41
206-12124-3.....	121	222-13618-5.....	78	223-10670-3.....	59	223-12295-6	41
206-12125-4.....	121	222-13670-1.....	78	223-10688-1	59	223-12295-8	41
207-168-2.....	123	222-13678-1.....	78	223-10814-2.....	44	223-12295-9	41
207-168.U2	123	222-13678-2.....	78	223-10889-2	60	223-12296-1.....	41
207-168.U7	123	222-13678-3.....	78	223-10986-1	47	223-12296-3	41
207-188-2.....	123	222-13678-4.....	78	223-11089-3	46	223-12296-5	41
207-188.U11	123	222-13678-8.....	78	223-11185-1.....	54	223-12296-8	41
210-042.....	33	222-14180-3.....	78	223-11229-9.....	46	223-12296-9	41
213-870.....	147	222-14180-5.....	78	223-11242-4.....	43	223-12359-6	44
213-870F*.....	147	222-14180-6.....	78	223-11242-5.....	43	223-12360-6	44
213-870.U1	147	222-14180-7.....	78	223-12270-7.....	44	223-12360-8	44
213-870.U2	147	222-14180-9.....	78	223-12270-8	44	223-12361-6.....	43
213-870.U2	147	223-10055-9	46	223-12270-9.....	44	223-12361-9.....	44
213-880.....	147	223-10080-3	44	223-12271-7.....	43	223-12362-4	50
213-880.U1	147	223-10187-1.....	59	223-12271-8.....	43	223-12362-8	50
213-930F.....	147	223-10263-8	43	223-12272-9.....	44	223-12363-2	46
220-12238-3	149	223-10297-1.....	71	223-12272-9.....	128	223-12363-6	46
222-10365-3	78	223-10297-5	71	223-12273-2.....	53	223-12364-4.....	47
222-11053-1.....	78	223-10297-6	71	223-12273-5.....	44	223-12364-6.....	56
222-12047-2.....	78	223-10297-7.....	71	223-12273-5.....	44	223-12365-2	50
222-12047-4.....	78	223-10297-9	71	223-12280-9	50	223-12366-2	49
222-12047-8.....	78	223-10307-2	53	223-12284-7.....	58	223-12366-6	49
222-12521-2.....	78	223-10313-2.....	43	223-12285-5	58	223-12367-2.....	49
222-12521-4.....	78	223-10313-7.....	44	223-12285-6	58	223-12367-4.....	49
222-12521-5.....	78	223-10364-3	56	223-12285-7.....	58	223-12368-2	56
222-12521-6.....	78	223-10364-6	56	223-12285-8	58	223-12368-4	56
222-12521-8.....	78	223-10374-3.....	63	223-12285-9	58	223-12368-6	56
222-12578-2.....	78	223-10389-3	57	223-12286-8	60	223-12368-8	56
222-12578-3.....	78	223-10389-4	58	223-12287-8	59	223-12369-7.....	57
222-12578-4.....	78	223-10530-4	79	223-12288-2	59	223-12369-9	58
222-12578-5.....	78	223-10540-1.....	153	223-12290-2	54	223-12372-9.....	54

Index

223-12373-2.....	42	223-12477-8.....	44	223-12577-2.....	59	223-13050-3.....	56
223-12373-6.....	42	223-12477-9.....	44	223-12577-8.....	59	223-13050-4.....	56
223-12373-9.....	42	223-12479-5.....	58	223-12580-2.....	59	223-13051-1.....	54
223-12374-2.....	42	223-12479-8.....	58	223-12581-9.....	59	223-13051-2.....	54
223-12374-6.....	42	223-12479-9.....	58	223-12582-5.....	59	223-13052-8.....	54
223-12374-7.....	42	223-12480-2.....	57	223-12583-1.....	41	223-13054-4.....	59
223-12374-8.....	42	223-12480-7.....	57	223-13016-2.....	44	223-13057-2.....	49
223-12374-9.....	42	223-12481-4.....	60	223-13016-3.....	44	223-13057-4.....	49
223-12377-7.....	45	223-12481-6.....	60	223-13016-4.....	44	223-13057-5.....	49
223-12377-8.....	45	223-12481-8.....	60	223-13016-6.....	44	223-13069-1.....	43
223-12380-6.....	51	223-12482-9.....	46	223-13016-7.....	44	223-13079-1.....	54
223-12409-2.....	56	223-12483-2.....	50	223-13016-9.....	44	223-13096-2.....	44
223-12409-6.....	56	223-12483-5.....	50	223-13021-1.....	43	223-13096-2.....	44
223-12409-8.....	56	223-12483-8.....	50	223-13021-3.....	50	223-13610-8.....	46
223-12409-9.....	56	223-12484-2.....	49	223-13021-4.....	51	223-13610-9.....	44
223-12423-7.....	52	223-12484-6.....	49	223-13021-6.....	51	223-13614-6.....	45
223-12429-1.....	54	223-12485-2.....	50	223-13021-7.....	51	223-13614-7.....	45
223-12432-2.....	52	223-12485-8.....	50	223-13023-1.....	43	223-13614-9.....	45
223-12432-8.....	52	223-12531-2.....	46	223-13023-3.....	50	223-13615-3.....	46
223-12452-5.....	45	223-12531-4.....	46	223-13024-1.....	47	223-13615-5.....	46
223-12452-7.....	45	223-12531-6.....	46	223-13024-4.....	47	223-13615-6.....	46
223-12452-8.....	47	223-12531-8.....	46	223-13024-8.....	47	223-13616-3.....	49
223-12452-9.....	45	223-12531-9.....	46	223-13025-6.....	49	223-13619-2.....	47
223-12453-1.....	51	223-12533-5.....	43	223-13028-2.....	60	223-13619-9.....	47
223-12454-1.....	46	223-12533-9.....	43	223-13028-4.....	60	223-13620-8.....	51
223-12454-3.....	46	223-12535-5.....	54	223-13032-1.....	42	223-13621-1.....	44
223-12454-5.....	46	223-12535-9.....	54	223-13032-3.....	42	223-13621-6.....	44
223-12454-6.....	46	223-12541-5.....	49	223-13032-4.....	42	223-13621-8.....	44
223-12454-8.....	46	223-12542-2.....	47	223-13032-6.....	42	223-13622-1.....	47
223-12455-1.....	49	223-12542-7.....	47	223-13032-9.....	42	223-13622-3.....	47
223-12455-2.....	49	223-12562-2.....	50	223-13033-2.....	53	223-13622-7.....	47
223-12455-5.....	49	223-12562-7.....	50	223-13040-1.....	63	223-13629-1.....	58
223-12456-1.....	58	223-12562-8.....	50	223-13040-3.....	61	223-13638-1.....	42
223-12456-6.....	57	223-12563-2.....	49	223-13040-7.....	61	223-13638-2.....	42
223-12456-7.....	58	223-12563-5.....	49	223-13040-9.....	61	223-13638-3.....	42
223-12456-8.....	57	223-12563-9.....	49	223-13048-1.....	51	223-13638-6.....	42
223-12456-9.....	58	223-12564-2.....	56	223-13048-5.....	51	223-13638-7.....	42
223-12477-1.....	44	223-12564-3.....	56	223-13048-6.....	51	223-13638-9.....	42
223-12477-2.....	44	223-12564-8.....	56	223-13048-8.....	51	223-13639-1.....	41
223-12477-6.....	44	223-12567-1.....	80	223-13049-3.....	46	223-13639-2.....	41
223-12477-6.....	128	223-12573-6.....	49	223-13050-2.....	56	223-13639-3.....	41

Index

223-13639-4.....	41	223-13677-2.....	50	223-13761-7.....	61	223-14189-5.....	63
223-13639-5.....	41	223-13677-5.....	51	223-13766-1.....	44	223-14189-6.....	63
223-13639-7.....	41	223-13679-3.....	58	223-13766-6.....	44	223-14189-7.....	63
223-13639-8.....	41	223-13679-8.....	58	223-13766-9.....	46	223-14189-9.....	63
223-13639-9.....	41	223-13679-9.....	58	223-13770-2.....	55	223-14190-1.....	61
223-13640-1.....	65	223-13681-1.....	54	223-13770-5.....	55	223-14190-2.....	61
223-13640-2.....	65	223-13684-2.....	54	223-13770-6.....	55	223-14190-4.....	61
223-13640-3.....	65	223-13685-1.....	60	223-13770-8.....	55	223-14190-5.....	61
223-13640-4.....	65	223-13685-3.....	60	223-13785-8.....	63	223-14190-6.....	61
223-13640-5.....	65	223-13686-1.....	48	223-13791-5.....	47	223-14190-7.....	61
223-13640-8.....	65	223-13692-3.....	55	223-14082-3.....	42	223-14214-2.....	44
223-13640-9.....	65	223-13693-1.....	53	223-14082-5.....	42	223-14214-2.....	44
223-13643-1.....	55	223-13693-2.....	53	223-14082-6.....	42	223-14214-4.....	44
223-13643-2.....	55	223-13693-4.....	53	223-14083-3.....	41	223-14214-5.....	44
223-13643-3.....	55	223-13693-6.....	53	223-14089-5.....	58	223-14214-5.....	44
223-13643-4.....	55	223-13693-9.....	53	223-14089-6.....	58	223-14214-8.....	43
223-13643-6.....	55	223-13694-1.....	64	223-14089-9.....	57	223-14214-9.....	44
223-13643-8.....	55	223-13694-3.....	64	223-14092-5.....	41	223-14215-2.....	65
223-13655-1.....	60	223-13694-6.....	64	223-14102-3.....	63	223-14215-3.....	65
223-13655-2.....	60	223-13694-7.....	64	223-14116-2.....	53	223-14215-4.....	65
223-13655-4.....	60	223-13698-4.....	56	223-14116-9.....	53	223-14215-5.....	65
223-13655-5.....	60	223-13700-7.....	155	223-14129-1.....	46	223-14234-4.....	46
223-13655-7.....	60	223-13700-8.....	155	223-14129-2.....	46	223-14234-7.....	46
223-13655-7.....	64	223-13700-9.....	155	223-14129-3.....	44	223-14238-4.....	58
223-13655-8.....	64	223-13702-1.....	79	223-14129-4.....	43	223-14240-5.....	51
223-13655-9.....	64	223-13702-5.....	79	223-14130-2.....	48	223-14241-2.....	71
223-13658-2.....	45	223-13702-6.....	79	223-14130-2.....	48	223-14241-5.....	71
223-13658-4.....	45	223-13702-7.....	79	223-14130-7.....	48	223-14241-9.....	71
223-13658-5.....	43	223-13702-9.....	79	223-14130-9.....	48	223-14244-6.....	61
223-13658-6.....	43	223-13705-5.....	47	223-14152-2.....	59	223-14244-8.....	61
223-13658-7.....	43	223-13706-3.....	55	223-14171-1.....	63	223-14253-1.....	48
223-13658-9.....	45	223-13715-1.....	43	223-14171-4.....	63	223-14253-2.....	48
223-13669-3.....	58	223-13715-6.....	45	223-14171-5.....	63	223-14253-3.....	48
223-13669-4.....	57	223-13715-9.....	45	223-14171-8.....	63	223-14253-4.....	48
223-13671-2.....	56	223-13732-4.....	46	223-14184-2.....	45	223-14253-5.....	48
223-13671-9.....	56	223-13732-8.....	46	223-14184-5.....	43	223-14268-4.....	60
223-13672-3.....	49	223-13749-3.....	44	223-14187-4.....	48	223-14268-7.....	60
223-13672-8.....	49	223-13749-5.....	44	223-14187-4.....	48	223-14293-1.....	59
223-13673-4.....	118	223-13758-4.....	56	223-14189-1.....	63	223-14293-2.....	59
223-13675-2.....	50	223-13759-7.....	59	223-14189-2.....	63	223-14293-4.....	59
223-13675-6.....	50	223-13761-5.....	61	223-14189-3.....	63	223-14293-8.....	59

Index

223-14304-2..... 46	226-12335-7..... 117	226-14139-1..... 85	251-14063-1..... 143
223-14304-5..... 46	226-12337-1..... 117	226-14157-1..... 86	251-14063-4..... 143
223-14304-7..... 46	226-12337-2..... 118	226-14157-2..... 86	251-14063-9..... 143
223-14418-7..... 46	226-12337-3..... 118	226-14157-3..... 86	251-14073-9..... 143
223-14420-7..... 45	226-12337-4..... 118	226-14157-4..... 88	251-14109-2..... 143
223-14420-8..... 45	226-12337-5..... 118	226-14157-5..... 88	251-14109-3..... 143
223-14424-5..... 50	226-12337-6..... 118	233-13651-1..... 151	267-001.03..... 75
223-14464-1..... 55	226-12338-1..... 117	233-13651-6..... 151	267-001.13..... 18
223-14464-9..... 54	226-12338-2..... 118	233-14419-1..... 151	267-001.17..... 18
223-14464-9..... 54	226-12338-3..... 118	234-10396-2..... 137	267-001.19..... 18
223-14497-1..... 48	226-12338-4..... 118	234-10396-9..... 137	267-001.36..... 75
223-14497-3..... 48	226-12338-5..... 118	234-10898-4..... 137	267-001.47..... 75
223-14497-4..... 48	226-12338-6..... 118	234-13101-2..... 137	267-001.60..... 75
223-14497-8..... 48	226-12343-1..... 120	234-13101-4..... 137	301-001..... 18
225-12324-3..... 112	226-12343-2..... 120	234-13132-7..... 137	301-001DK..... 24
225-12324-5..... 112	226-12343-5..... 120	234-13132-8..... 137	301-005..... 18
225-12324-8..... 112	226-12508-5..... 157	234-13136-2..... 137	301-005-S3..... 18
225-12325-1..... 112	226-13058-3..... 120	234-13156-6..... 137	301-020..... 18
225-12325-2..... 112	226-13058-5..... 120	234-13182-7..... 137	301-020..... 127
225-12414-6..... 112	226-13095-7..... 157	234-13182-8..... 137	301-020..... 128
225-12414-7..... 112	226-13097-3..... 120	235-13108-4..... 132	301-020-S3..... 18
225-12414-8..... 112	226-13673-1..... 117	235-13114-1..... 132	301-034..... 76
225-12486-5..... 112	226-13673-5..... 118	243-001.10..... 75	301-134..... 76
225-12576-1..... 112	226-13717-1..... 117	243-001.20..... 75	303-17546-1..... 149
225-12576-2..... 112	226-13717-2..... 118	248-602.20..... 135	304-16337-1..... 76
225-12576-3..... 112	226-13717-3..... 118	248-602.25..... 135	304-19167-1..... 76
225-13039-2..... 112	226-13717-4..... 118	248-610.01..... 75	304-19230-1..... 76
225-13039-8..... 112	226-13718-1..... 118	248-803.16..... 156	304-19437-1..... 76
226-10159-1..... 89	226-13753-9..... 87	248-803.17..... 156	304-19509-1..... 76
226-10159-9..... 89	226-13756-9..... 86	248-803.20..... 156	304-19548-1..... 76
226-10205-5..... 85	226-13773-4..... 91	251-10309-1..... 143	304-19787-1..... 76
226-10214-4..... 90	226-14097-4..... 90	251-10309-2..... 143	321-581..... 99
226-10214-7..... 90	226-14097-5..... 89	251-10780-2..... 143	322-581..... 99
226-10223-2..... 88	226-14111-1..... 85	251-14040-1..... 143	322-861..... 99
226-10223-4..... 88	226-14111-2..... 86	251-14040-2..... 143	323-581..... 99
226-10223-6..... 88	226-14111-3..... 86	251-14040-3..... 143	324-581..... 99
226-10622-8..... 86	226-14111-4..... 86	251-14040-4..... 143	324-861..... 99
226-11313-8..... 87	226-14123-2..... 87	251-14040-5..... 143	325-581..... 99
226-11313-9..... 87	226-14123-3..... 87	251-14044-8..... 143	326-581..... 99
226-11315-1..... 87	226-14123-4..... 87	251-14045-1..... 143	326-663..... 99
226-11315-2..... 87	226-14123-5..... 87	251-14045-8..... 143	328-581..... 99

Index

328-861.....	99	404-002-S3	15	404-673K-V1-VS	93	406-163.....	18
330-581.....	99	404-003	18	405-549-049	34	406-165K.....	77
330-861.....	99	404-003DK	24	405-551-049	34	406-166.....	18
332-861.....	99	404-003K	17	405-619-061.....	32	406-167.....	18
334-861.....	99	404-003-S8-VS.....	93	406-001.....	14	406-203	27
336-861.....	99	404-003-VS	93	406-001-S3	14	406-233.....	27
338-861.....	99	404-004.....	18	406-002	15	406-243-B	27
340-861.....	99	404-005.....	18	406-002-S3	15	406-351.....	41
401-004-512.....	17	404-006	18	406-004	18	406-352.....	42
401-004-903	17	404-006DK	24	406-004DK.....	24	406-361.....	41
401-004-904	17	404-006K	17	406-004K	17	406-362.....	42
401-011-132.....	75	404-006-S8-VS.....	93	406-004-S3	18	406-362.....	42
401-013-131.....	75	404-006-VS	93	406-004-S8-VS.....	93	406-405.....	50
401-013-161.....	75	404-008	25	406-004-VS	93	406-423N-VS.....	93
401-013-171.....	75	404-009	25	406-005	25	406-423W-VS.....	93
401-016-312.....	75	404-010.....	24	406-008	25	406-426-VS	94
401-016-371.....	75	404-011.....	37	406-010.....	24	406-603	15
401-019-132.....	75	404-040.....	18	406-011.....	37	406-611.....	16
401-019-352.....	75	404-040K	17	406-024.....	75	406-612.....	16
401-504-192.....	35	404-040K-US	17	406-044-S1	74	406-612-MS	16
401-504-292.....	35	404-040K-V1-VS	93	406-045K	77	406-613.....	15
401-506-313.....	35	404-040-VS	93	406-054.....	18	406-704-001	111
402-001 ¹⁾	14	404-045.....	17	406-054.....	127	406-704-001-VS	111
402-002	15	404-047K.....	17	406-054K	17	406-706-001	111
402-003	18	404-054K.....	17	406-054-VS	93	406-706-001-VS	111
402-003K	17	404-061.....	18	406-055.....	18	406-708-001	111
402-004	18	404-063.....	18	406-089K	77	406-708-001-VS	111
402-006	18	404-063-VS	93	406-090K	77	406-708-005	115
402-006K	17	404-072.....	17	406-091K.....	77	406-708-005-S3	115
402-008K	17	404-073-VS	93	406-092K	77	406-708-005-VS	115
402-011.....	37	404-162.....	18	406-093K	77	406-708-006	115
402-116-161.....	26	404-164.....	18	406-094K	77	406-708-007	115
402-116-165.....	26	404-203.....	27	406-103.....	27	406-708-008	115
402-603	15	404-405-S3	50	406-145K.....	77	406-708-009	115
402-606-191.....	32	404-603.....	15	406-155K.....	77	406-710-002	115
402-611.....	16	404-611.....	16	406-158.....	18	406-804-001	111
402-612.....	16	404-612.....	16	406-158-S3	18	406-805	24
403-006-651	29	404-612-MS	16	406-158-VS	93	406-806-001	111
404-001.....	14	404-662K	17	406-162.....	18	406-808-001	111
404-001-S3	14	404-663K	17	406-162-S8-VS.....	93	406-808-005	115
404-002	15	404-673K.....	17	406-162-VS	93	406-808-005-S3	115

Index

406-810-002	115	410-001	14	412-403	43	443-218-001	50
408-001	14	410-002	15	412-405	50	443-290-001	50
408-001-S3	14	410-003	27	412-405W	51	443-306-343	63
408-004	18	410-003-B	27	412-407	49	443-410-161	61
408-004-S8-VS	93	410-004	19	412-409	56	443-410-211	61
408-004-VS	93	410-004DK	24	412-423	43	443-418-181	61
408-005	18	410-008	25	412-423W	167	445-513-181	58
408-006	18	410-010	24	412-433	43	445-517-222	58
408-008	25	410-011	37	412-453	43	445-519-041-VS	94
408-010	24	410-013	28	412-453W	44	445-535-101	57
408-011	37	410-018	19	412-603	15	445-713-151	62
408-013	28	410-022	19	412-611	16	445-717-221	62
408-022	18	410-160	19	412-612	16	445-721-121	62
408-023	27	410-162	19	415-403	43	445-735-101	62
408-033-S3	27	410-163	19	415-405	50	445-739-151	62
408-054-VS	93	410-163	127	415-413	43	445-806-351	63
408-103	27	410-163	128	415-443W	44	445-910-551	62
408-120	35	410-164	19	417-012-313	68	446-308-001	52
408-154	18	410-169	19	418-403	43	446-310-001	52
408-160	18	410-171	19	418-405W	51	446-312-001	52
408-160	128	410-313	46	418-407	49	446-315-001	52
408-162	18	410-403-S3	43	418-409	56	450-204-002	97
408-162-S8-VS	93	410-413	43	418-413W	44	450-206-002	97
408-162-VS	93	410-443	43	422-416	56	451-004-260-VS	93
408-202	15	410-443W	44	428-21543-2	149	451-004-462-VS	93
408-202-S3	15	410-603	15	428-21544-1	148	451-004-471-VS	93
408-211	37	410-611	16	428-21544-1	149	451-004-498-VS	93
408-243-B	27	410-612	16	428-21545-1	149	451-004-518-VS	93
408-313	46	410-612-MS	16	428-21546-2	149	451-006-468-VS	93
408-351	41	412-001	14	432-23077-1	161	451-006-498-VS	93
408-352	42	412-002	15	432-23676-1	115	451-006-518-VS	93
408-361	41	412-004	19	432-24043-1	77	453-004-471-S8-VS	95
408-362	42	412-008	25	432-24050-1	77	453-004-471-VS	95
408-362	42	412-010	24	432-24051-1	77	453-006-468-S8-VS	95
408-413	43	412-011	37	432-24052-1	77	453-006-468-VS	95
408-425W	51	412-014	19	432-70024-1	144	453-006-651-VS	95
408-453W	44	412-162	19	432-70673-1	77	454-504-041-VS	94
408-603	15	412-163	19	432-70674-1	77	455-529-048-S8-VS	97
408-611	16	412-163	128	432-71483-1	77	455-529-048-VS	97
408-612	16	412-164	19	433-890-131	75	455-529-068-S8-VS	97
408-612-MS	16	412-169	19	441-108-132	60	455-529-068-VS	97

Index

455-531-048-S8-VS 97	471-010-211 67	502-056 31	504-102-VS 96
455-531-048-VS 97	471-010-312 67	502-101 31	504-103 28
455-531-068-S8-VS 97	471-010-312 68	502-102 31	504-103-VS 94
455-531-068-VS 97	471-010-318 68	502-154 31	504-105 32
455-546-048-S8-VS 97	471-010-351 67	502-161 31	504-106 33
455-546-048-VS 97	471-010-391 67	502-206K 29	504-108 31
455-546-068-VS 97	471-012-161 67	504-003 28	504-108-S8-VS 96
455-565-068-VS 97	471-012-211 67	504-004 20	504-108-VS 96
455-569-048-VS 97	471-012-312 68	504-008 22	504-109 33
456-004K 17	471-012-391 67	504-019 37	504-110 33
456-004-S8-VS 93	473-806-351 70	504-019-AL 37	504-111 33
456-004-VS 93	473-806-391 70	504-027 31	504-112 33
458-012 27	473-808-371 70	504-027 31	504-114 32
458-012-B 27	473-808-392 70	504-045 23	504-115 32
460-708-001 71	473-810-371 70	504-051 33	504-161 31
466-419-001 79	473-810-391 70	504-051 33	504-161-VS 94
466-429-001 79	474-506-061 69	504-051 33	504-162 31
466-431-001 79	474-508-081 69	504-052 31	504-200K 30
466-431-005 79	474-510-101 69	504-052 31	504-200K-V1-VS 95
466-431-006 79	474-512-121 69	504-052 32	504-201K 30
466-431-009 79	474-515-151 69	504-052 32	504-201-S8-VS 95
466-439-001 79	474-518-181 69	504-052 32	504-201-VS 95
471-004-191 67	474-606-331 68	504-054 31	504-202K 30
471-004-311 67	474-608-351 68	504-054 31	504-202-S8-VS 95
471-006-161 67	474-610-351 68	504-054 33	504-202-VS 95
471-006-192 67	474-612-391 68	504-056 32	504-203K 30
471-006-311 67	474-615-431 68	504-056 33	504-401 31
471-006-319 68	474-618-441 68	504-071 33	504-401-S1-VS 94
471-006-320 68	476-006-001 69	504-071 33	504-401-VS 94
471-006-351 67	476-008-001 69	504-071 33	504-411 31
471-008-130 67	476-010-001 69	504-072 31	504-411-VS 94
471-008-131 67	476-012-001 69	504-072 32	504-412 47
471-008-161 67	476-015-001 69	504-073 31	504-510K 29
471-008-211 67	502-051 31	504-073 33	504-651 31
471-008-312 68	502-051 31	504-075 32	504-651 31
471-008-314 67	502-052 31	504-100-VS 96	504-851 31
471-008-318 68	502-053 31	504-101 31	504-851 31
471-008-345 67	502-053 31	504-101-S8-VS 96	504-37184-2 144
471-008-351 67	502-054 31	504-101-VS 96	504-37210-1 144
471-008-391 67	502-054 31	504-102 31	504-37211-1 144
471-010-161 67	502-056 31	504-102-S8-VS 96	506-004 28

Index

506-005	31	506-142-S8-VS	96	508-012.....	32	508-512K.....	29
506-005	31	506-142-VS	96	508-013.....	33	508-602-2	22
506-005	32	506-143-VS.....	96	508-014.....	33	510-010.....	32
506-005	32	506-145.....	31	508-023	31	510-010.....	32
506-006	32	506-202K	29	508-023	31	510-010.....	32
506-006	33	506-214.....	31	508-023	31	510-017.....	31
506-007.....	33	506-242.....	33	508-023	33	510-017.....	31
506-007.....	33	506-342.....	32	508-024	31	510-017.....	31
506-007.....	33	506-345.....	32	508-025	33	510-023.....	31
506-008	22	506-346.....	32	508-030	31	510-023.....	32
506-010.....	20	506-408	22	508-030	32	510-024.....	31
506-012.....	31	506-442.....	33	508-030	32	510-041.....	31
506-013.....	32	506-508K	29	508-030	32	510-041.....	32
506-014.....	33	506-508-S8-VS	95	508-032.....	33	510-041.....	32
506-018.....	32	506-508-VS	95	508-032.....	33	510-042.....	33
506-025.....	33	506-510K.....	29	508-032.....	33	510-044.....	31
506-026	33	506-510-S8-VS	95	508-033	32	510-044.....	32
506-030	31	506-510-VS	95	508-034	32	510-044.....	32
506-030	32	506-511K-V1-VS	95	508-054.....	31	510-102.....	22
506-030	32	506-511-S8-VS	95	508-054.....	32	510-142.....	31
506-030	32	506-511-VS.....	95	508-108.....	37	510-145.....	31
506-032.....	33	506-512K.....	29	508-108.....	128	510-242.....	33
506-032.....	33	506-512-VS	95	508-108.....	128	510-341.....	32
506-032.....	33	508-002-2	22	508-142.....	31	510-342.....	32
506-033	31	508-005	33	508-142-S8-VS	96	510-343.....	32
506-033	31	508-005	33	508-142-VS	96	510-344.....	32
506-033	32	508-005	33	508-144.....	31	510-346.....	32
506-034.....	31	508-005	33	508-145.....	31	510-410.....	47
506-034.....	32	508-006	31	508-215-CU	37	510-413.....	47
506-056.....	32	508-006	31	508-242.....	33	510-442.....	33
506-101.....	32	508-006	33	508-303	32	512-412.....	47
506-108.....	31	508-006	33	508-303	32	514-018K.....	29
506-108-S8-VS	96	508-007.....	31	508-303	33	514-018K-S1.....	30
506-108-VS	96	508-007.....	31	508-303	33	514-018K-V1-VS	95
506-114	32	508-007.....	32	508-304	32	514-018-S8-VS	95
506-139-S8-VS	96	508-007.....	32	508-305	33	514-018-VS.....	95
506-139-VS	96	508-007.....	32	508-320-CU	37	515-410.....	47
506-140.....	31	508-008	32	508-342.....	32	525-32080-1	133
506-140-S8-VS	96	508-008	32	508-345.....	32	525-32081-1.....	133
506-140-VS	96	508-008	33	508-346.....	32	525-32082-1.....	133
506-142.....	31	508-008	33	508-442.....	33	525-32083-1.....	133

Index

525-32084-1.....	133	604-015.....	118	666-34221-9	113	714-400-M-VS	108
525-32085-1.....	133	604-016.....	118	666-34578-5.....	113	714-420.....	106
525-32086-1.....	133	604-018.....	118	666-34578-9.....	113	714-420-K.....	107
525-32087-1.....	133	604-36879-1	158	666-34639-5	113	714-420-VS.....	108
525-32098-1.....	133	606-010.....	117	666-36059-8	113	714-450.....	106
528-31341-3.....	148	606-014.....	119	666-36081-7	113	714-450-K.....	107
528-36045-6	148	608-001	117	666-36081-8	113	714-450-VS.....	108
532-32131-1.....	144	608-003	117	666-36081-9	113	714-500.....	106
532-32248-1.....	144	608-004	119	666-36087-1	113	714-500-K.....	107
532-32454-1.....	144	610-001.....	117	666-36087-2	113	714-500-M	106
558-012.....	31	610-004.....	119	666-36087-3	113	714-500-MK	107
558-012.....	31	612-001.....	117	666-36087-7	113	714-500-M-VS	108
558-012.....	31	624-25294-1.....	129	666-36087-8	113	714-500-VS.....	108
558-012.....	33	624-25465-1.....	129	666-36831-9	113	714-580.....	106
558-012.....	33	624-25478-1.....	129	666-85311-1.....	113	714-580-K.....	107
558-012.....	33	624-25479-1.....	129	714-180.....	106	714-580-M	106
558-612.....	32	624-25480-1	129	714-180-K.....	107	714-580-MK	107
558-612.....	32	624-25482-1.....	129	714-180-M	106	714-580-M-VS	108
558-612.....	33	624-25483-1	129	714-180-MK	107	714-580-VS.....	108
558-612.....	33	624-27092-1.....	129	714-180-M-VS	108	716-220.....	106
558-812.....	32	625-25481-1.....	129	714-180-VS.....	108	716-220-K.....	107
558-812.....	32	626-25438-2	80	714-220.....	106	716-220-VS	108
558-812.....	32	626-25540-2	80	714-220-K.....	107	716-300.....	106
558-812.....	33	626-25702-1.....	80	714-220-VS.....	108	716-300-K.....	107
558-812.....	33	626-25716-2.....	80	714-260.....	106	716-300-M	106
558-912.....	32	626-25717-2.....	80	714-260-K.....	107	716-300-MK	107
558-912.....	32	626-25720-2.....	80	714-260-M	106	716-300-M-VS.....	108
558-912.....	32	626-26246-1	123	714-260-MK	107	716-300-VS	108
558-912.....	33	626-26696-2	80	714-260-M-VS	108	716-340.....	106
558-913.....	32	626-26700-2	80	714-260-VS.....	108	716-340-K.....	107
568-342.....	32	626-26701-2.....	80	714-300.....	106	716-340-VS	108
568-442.....	33	628-25531-2	148	714-300-K.....	107	716-380.....	106
586-342.....	32	628-26452-2	148	714-300-M	106	716-380-K.....	107
586-442.....	33	628-36062-3	148	714-300-MK	107	716-380-VS	108
602-001.....	117	651-28685-1.....	140	714-300-M-VS	108	716-400-M	106
602-002	117	651-28691-1.....	140	714-300-VS	108	716-400-MK	107
604-001.....	117	651-29124-1.....	140	714-380.....	106	716-400-M-VS.....	108
604-002	117	666-34028-2	113	714-380-K.....	107	716-420.....	106
604-003	117	666-34028-3	113	714-380-VS.....	108	716-420-K.....	107
604-004	119	666-34220-1	113	714-400-M	106	716-420-VS	108
604-014.....	118	666-34221-5	113	714-400-MK	107	716-450-MK	107

Index

716-450-M-VS.....108	734-380.....109	855-380-003.....115	982-120-100.....104
716-460-M.....106	734-380-K.....109	855-380-003-VS.....115	982-120-180.....104
716-500.....106	734-380-VS.....110	871-340-006.....145	982-760-102.....103
716-500-K.....107	734-420.....109	871-340-008.....145	982-760-120.....103
716-500-M.....106	734-420-K.....109	871-360-006.....145	982-760-122.....103
716-500-MK.....107	734-420-VS.....110	871-360-008.....145	982-760-130.....103
716-500-M-VS.....108	734-450.....109	871-380-006.....145	982-760-132.....103
716-500-VS.....108	734-450-K.....109	871-390-020.....145	982-760-142.....103
716-580.....106	734-450-VS.....110	871-390-023.....145	982-760-160.....103
716-580-K.....107	734-500.....109	898-510-000.....120	982-760-172.....103
716-580-VS.....108	734-500-K.....109	898-610-000.....120	995-000-705.....124
718-340.....106	734-500-VS.....110	898-710-000.....120	995-000-705.....167
718-340-K.....107	734-580.....109	898-710-001.....120	995-001-096.....124
718-340-VS.....108	734-580-K.....109	902-111.....14	995-001-104.....21
718-400-M.....106	734-580-VS.....110	904-411.....14	995-001-106.....21
718-400-MK.....107	843-130-021.....74	906-411.....14	995-001-235.....124
718-400-M-VS.....108	843-130-022.....74	908-411.....14	995-001-260.....124
718-450.....106	843-130-023.....74	910-411.....14	995-001-500.....124
718-450-K.....107	844-330-006.....154	912-411.....14	995-001-500.....167
718-450-M.....106	844-330-007.....154	917-877.....160	995-001-501.....124
718-450-MK.....107	844-330-007.....154	941-206-104.....119	995-001-502.....124
718-450-M-VS.....108	853-370-002.....115	941-206-108.....119	995-001-503.....124
718-450-VS.....108	853-380-002.....115	941-208-104.....119	995-001-504.....124
718-500-M.....106	853-380-002-VS.....115	941-209-104.....119	995-001-525.....123
718-500-MK.....107	853-380-003.....115	941-209-105.....119	995-001-526.....123
718-500-M-VS.....108	853-380-003-VS.....115	941-210-104.....119	995-001-620.....125
718-580.....106	853-380-004.....115	941-212-104.....119	995-001-621.....125
718-580-K.....107	853-380-004-VS.....115	941-213-104.....119	995-001-622.....125
718-580-VS.....108	853-380-006-VS.....115	941-215-104.....119	995-001-623.....125
734-180.....109	853-380-007-VS.....115	941-217-104.....119	995-001-950.....124
734-180-K.....109	853-390-002.....115	941-217-105.....119	995-002-073.....124
734-180-VS.....110	853-390-002-VS.....115	941-218-101.....119	995-003-040.....141
734-220.....109	853-390-003.....115	941-220-104.....119	995-003-041.....141
734-220-K.....109	853-390-003-VS.....115	941-222-100.....119	995-003-042.....141
734-220-VS.....110	853-390-004-VS.....115	941-225-104.....119	995-003-043.....141
734-260.....109	853-390-005-VS.....115	941-606-000.....120	995-003-044.....141
734-260-K.....109	853-390-006-VS.....115	941-608-000.....120	995-014-014.....26
734-260-VS.....110	853-540-010.....115	941-610-000.....120	995-340-000.....26
734-300.....109	853-750-024.....27	982-120-040.....104	995-340-000-S8.....26
734-300-K.....109	855-380-002.....115	982-120-041.....104	995-340-350.....26
734-300-VS.....110	855-380-002-VS.....115	982-120-061.....104	995-340-350-S8.....26

Index

995-350-000	26	DAR534	21	DIN72573-1x6-NIRO	118	P-78.01	75
995-350-000-S8	26	DAT506	23	DIN72573-2x6-NIRO	118	UC.1010.100	151
996-001-890	143	DAT508	23	DIN 72573-2x6-ST	118	UC-1066-01	151
001013	164	DAT510	23	DIN 72573-2x8-ST	118	UC-1066-02	151
1110-00000001	114	DAT510-S1	23	DIN 72573-2x10-ST	118	UC-1066-03	151
1110-00000002	114	DAT510-S5	23	DIN72573-3x6-NIRO	118	UC-1066-04	151
001142	164	DAT512	23	DIN 72573-3x6-ST	118	UC-1066-05	151
1871	163	DIN 908-G1-8A-5.8	37	DIN 72573-3x8-ST	118	UC-1066-06	151
1886	163	DIN 908-G3-8A-5.8	37	DIN 72573-3x10-ST	118	UC-1066-10	151
1886-E	163	DIN 908-M10x1-5.8	37	DIN72573-4x6-NIRO	118	UC-1066-14	151
5590-00000002	165	DIN 908-M12x1,5-5.8	37	DIN 72573-4x6-ST	118	UFZ.0097	132
5841	159	DIN 908-M14x1,5-5.8	37	DIN 72573-4x8-ST	118	VL-01DAM3	99
068874	151	DIN910-R1-2-5.8	37	DIN 72573-4x10-ST	118	VL-01EAM3	99
91308	80	DIN910-R1-4x8-5.8	37	DIN72573-5x6-NIRO	118	VL-02DAM3	99
AC-2879	151	DIN910-R1-5.8	37	DIN 72573-5x6-ST	118	VL-02EAM3	99
AC-3398	151	DIN910-R1-8-5.8	37	DIN 72573-5x8-ST	118	VL-03DAM3	99
B3.U21	140	DIN910-R3-4-5.8	37	DIN 72573-5x10-ST	118	VL-03EAM3	99
B7	141	DIN910-R3-8-5.8	37	DIN72573-6x6-NIRO	118	VL-04DAM3	99
B7.U271	140	DIN912-M3x8-A4	121	DIN 72573-6x6-ST	118	VL-04EAM3	99
BW3-2-S1	141	DIN912-M4x12-A4	121	DIN 72573-6x8-ST	118	VL-05DAM3	99
BW7-S6	141	DIN912-M5x10-A2	121	DLY930-2	81	VL-05EAM3	99
BW7-S7	141	DIN931-M6x30-8.8	121	DLY931	81	VL-06DAM3	99
BW7-S8	141	DIN933-M4x10-8.8	121	DLY932	81	VL-06EAM3	99
BW7-S11	141	DIN2462-R04x1+A46	105	DY958	30	VL-08DAM3	99
BW7-S14	141	DIN2462-R010x1+A46	105	DY960	30	VL-08EAM3	99
D301-001-MS	18	DIN7513-BM4x20	121	DY961	30	VL-10DAM3	99
D301-005-MS	18	DIN7513-BM4x25	121	DY962	30	VL-10EAM3	99
D301-020-MS	18	DIN7513-BM6x25	121	DY964	23	WVN200-4A0.4	130
D408-004-MS	18	DIN7603-A6x10-CU	37	DZ333	75	WVN200-4A0.4-S1	130
D1127R02.5x0.5+A46	105	DIN7603-A8x11.5-CU	37	DZ334	75	WVN200-4A5	130
DAK504-S1	36	DIN7603-A12x18-CU	37	K1	139	WVN200-4A8	130
DAK506	36	DIN7603-A14x18-CU	37	K3-S2	139	WVN200-4A12	130
DAK508	36	DIN7603-A16x20-CU	37	K6-S5	139	WVN200-4A16	130
DAK510	36	DIN7603-A17x21-CU	37	K6-S6	139	WVN200-4A25	130
DAK510-S1	36	DIN7603-A18x22-CU	37	KW1	139	WVN200-6B0.5	130
DAK512	36	DIN7603-A20x24-CU	37	KW1-S2	139	WVN200-6B3	130
DAR506	20	DIN7603-A21x26-CU	37	KW3-S1	139	WVN200-6B8	130
DAR508	20	DIN7603-A22x27-CU	37	KW6-S1	139	WVN200-6B12	130
DAR510	20	DIN7603-A27x32-CU	37	KW6-S2	139	WVN200-6B16	130
DAR510-S1	20	DIN7603-A30x36-CU	37	KW6-S81	139	WVN200-6B20	130
DAR524	21	DIN7603-A33x39-CU	37	LAGN 120	145	WVN200-6B40	130

Index

WVN200-8B0.....	130	WVN701-4.....	111
WVN200-8B3.....	130	WVN701-6.....	111
WVN200-8B5.....	130	WVN701-8.....	111
WVN200-8B12.....	130	WVN711-10.....	114
WVN200-8B16.....	130	WVN715-R02.5X0.5.....	102
WVN200-8B20.....	130	WVN715-R04X0.85.....	102
WVN200-8B32.....	130	WVN715R04X0.85+A89..	102
WVN200-8D50.....	131	WVN715-R06X1.....	102
WVN200-8D75.....	131	WVN715-R06X1.25.....	102
WVN200-8D120.....	131	WVN715R06X1.25+A89..	102
WVN200-8D220.....	131	WVN715-R08x1.25.....	102
WVN200-10B0.....	130	WVN716-R04X0.85.....	102
WVN200-10B0.5.....	130	WVN716R04X0.85+A89..	102
WVN200-10B1.....	130	WVN716-R06X1.25.....	102
WVN200-10B32.....	130	WVN716R06X1.25+A89..	102
WVN200-10D120-S1....	131	WVN716-R08X1.25.....	102
WVN200-10D220-S1....	131		
WVN200-10E6.....	128		
WVN200-10E12.....	128		
WVN200-10E12-S8.....	128		
WVN200-10E25.....	128		
WVN200-10E25-S8.....	128		
WVN200-10E35.....	128		
WVN200-10E60.....	128		
WVN200-10E60-S8.....	128		



Important information on product usage

SKF and Lincoln lubrication systems or their components are not approved for use with gases, liquefied gases, pressurized gases in solution and fluids with a vapor pressure exceeding normal atmospheric pressure (1 013 mbar) by more than 0,5 bar at their maximum permissible temperature.



skf.com | skf.com/lubrication | lincolnindustrial.com

© SKF and LINCOLN are registered trademarks of the SKF Group.

© SKF Group 2020

The contents of this publication are the copyright of the publisher and may not be reproduced (even extracts) unless prior written permission is granted. Every care has been taken to ensure the accuracy of the information contained in this publication but no liability can be accepted for any loss or damage whether direct, indirect or consequential arising out of the use of the information contained herein.

PUB LS/P1 15859 EN · March 2020

Certain image(s) used under license from Shutterstock.com