

e-chains® | Series 11.080 | Non-openable. With moulded-in vertical separation

Part No.	Bi [mm]	Ba [mm]	R Available bend radii [mm]	Chamber design	A [mm]	B [mm]	Weight [kg/m]
11.080.R.0	80	93	038   065		46	32	≈ 0.73

Complete Part No. with required radius (R). Example: 11.080.038.0

Installation dimensions

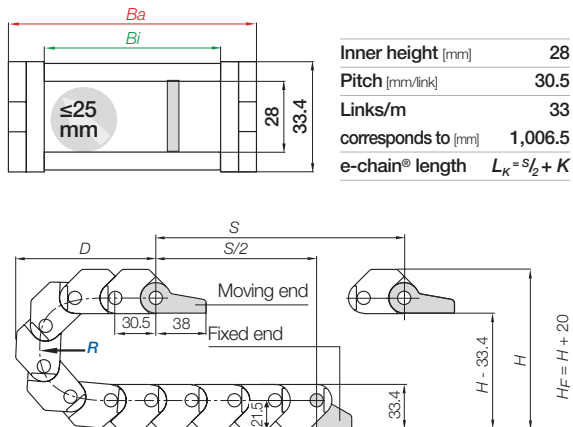
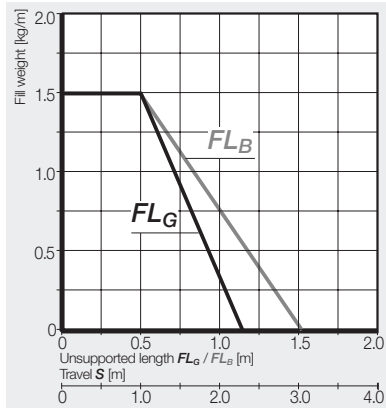

R	038	065
H	119	173
D	105	132
K	185	270

The required clearance height:  $H_f = H + 20\text{mm}$  (with 0.5kg/m fill weight)

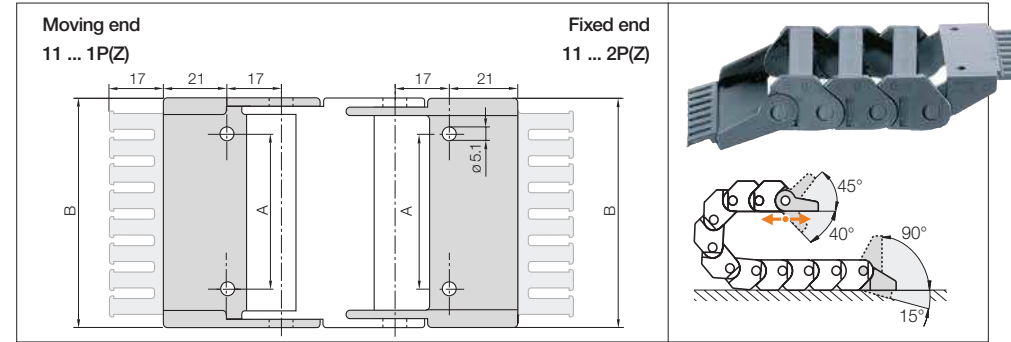

Width index	Part No. full set with tiewrap plates	Part No. full set without tiewrap plates	A [mm]	B [mm]	Number of teeth
080. ►	11.080.12PZ	11.080.12P	65	93	8

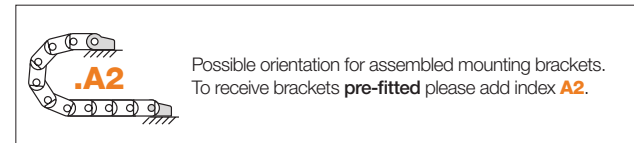

**11.080.12PZ.A2** Order example

- .A... to indicate option with brackets pre-fitted
- With integrated strain relief tiewrap plates
- Full set
- Series