

FOG CANNON HE15-R

The wall-mounted spray cannon is a very effective device for control dust indoor. However, it can be used also outdoor.

APPLICATIONS & INDUSTRIES

- demolition & construction
- steel & slag
- waste transfer
- recycling & scrap
- wood processing
- material unloading / loading
- odour control

BASIC MODEL INCLUDES

- rear mounted axial fan
- high-efficiency spray nozzles
- water filter, pressure gauge
- automatic oscillation
- manual tilting
- installation kit for the easy assembly on the wall / under the roof

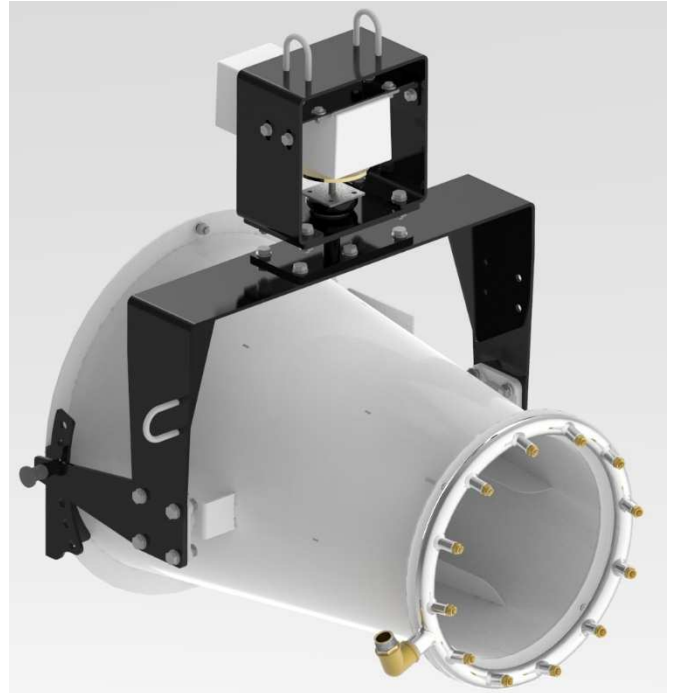

ADDITIONAL ACCESSORIES

- electric control panel
- wireless remote control

TECHNICAL SPECIFICATION	HE15-R
Throw (meters)	up to 15 (windless conditions)
Droplet size (µm)	50-150
Fan (kW)	2,2
Horizontal rotation	0-350°
Adjustable vertical elevation	up +15°, down -27°
Water consumption (l/h)	518
Nozzles quantity (pcs)	12
Power supply	1 x 230 V AC, 50 Hz