

2. LOCAL DUST COLLECTORS (P-SERIES) 2.4.1. TYPE P1500/12/R

DESCRIPTION

- **box-shaped dust collector for the local dedusting - big-bags filling, welding and cutting machines etc.**

OPERATION QUALITIES

- air volume: max. 5400 m³/h
- filtration area: 59,0 m²
- fan: 7,5 kW, 3 x 400 V AC, 50 Hz
- rest concentration at the outlet: <10 mg/m³
- temperature resistance: -20 °C/+80 °C
- compressed air: max. 6 bar, air consumption 6 Nm³/h
- pressure loss: 1500 Pa
- weight: 624 kg

DESIGN

- carbon steel construction
- filter element: 12 x filter cartridge made of polyester in basic design diameter 145 mm, length 1500 mm
- air tank with JET-PULS filter cartridges recovery and timer
- compressed air inlet: internal thread G 1/2"
- pulse and safety valves, pressure regulator
- pressure switch to indicate the filter cartridges are plugged
- support frame with the rotary valve 250 x 250, 0.55 kW

ADDITIONAL ACCESSORIES

- electric control panel: 3 x 400 V AC, 50 Hz
- noise silencer
- dedusting arms
- ATEX design
- stainless steel version
- non-standard temperature design: -40 °C/+150 °C

BENEFITS

- robust design
- easy filter element replacement
- low dust emission level
- excellent access to every filter component



Dust collector type P1500/12/R with the support frame and rotary valve is used for the local filtration – dedusting of big-bags filling, welding and cutting machines etc.

2. LOCAL DUST COLLECTORS (P-SERIES) 2.4.1. TYPE P1500/12/R

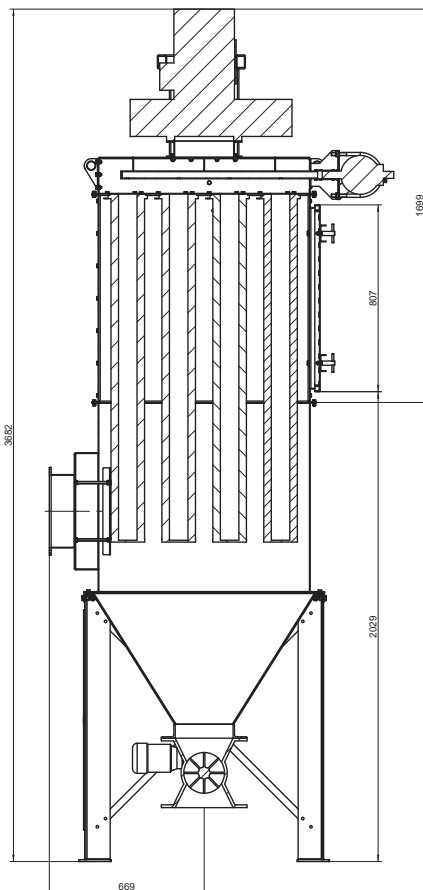
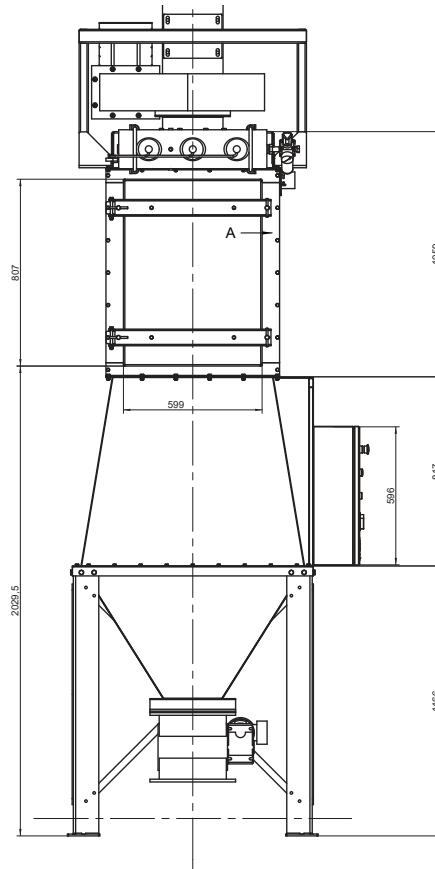
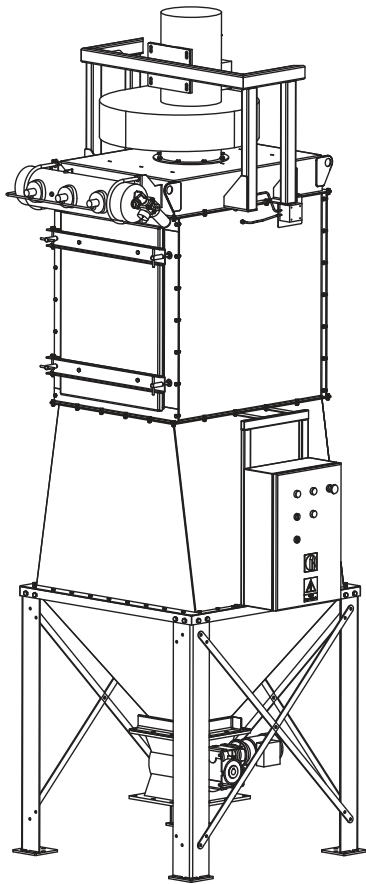

View B-B

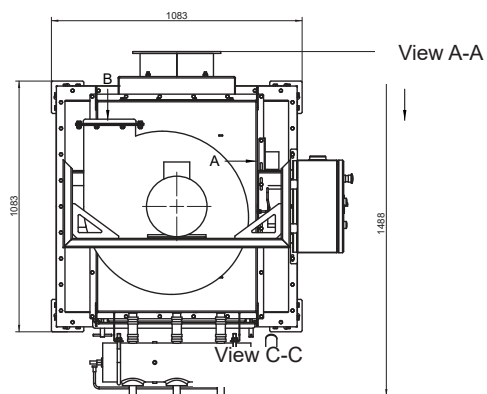

View A-A

View C-C