

T

Sealless Vertical Centrifugal Pumps
Made of PVDF or PP, Dry-Run Safe



Reinventing
flow.
Since 1964



Sealless Vertical Centrifugal Pumps

Made of PVDF or PP, Dry-Run Safe

Housing and impeller materials

PVDF, PP

Elastomers

EPDM, FKM (e.g. Viton®), FEP, FFKM (e.g. Kalrez®)

The T series transmits motor power vertically to the pump impeller via an extended shaft. The shaft operates without intermediate bearings in accordance with the cantilever design principle. This concept eliminates the need for additional bearings and, in its standard configuration, does not require a shaft seal. Optionally, the T series can be equipped with a shaft seal acting as a vapor barrier. Immersion depths of up to 800 mm are available. Additional suction pipe extensions up to 2 m are possible, depending on pump size.

Performance Overview

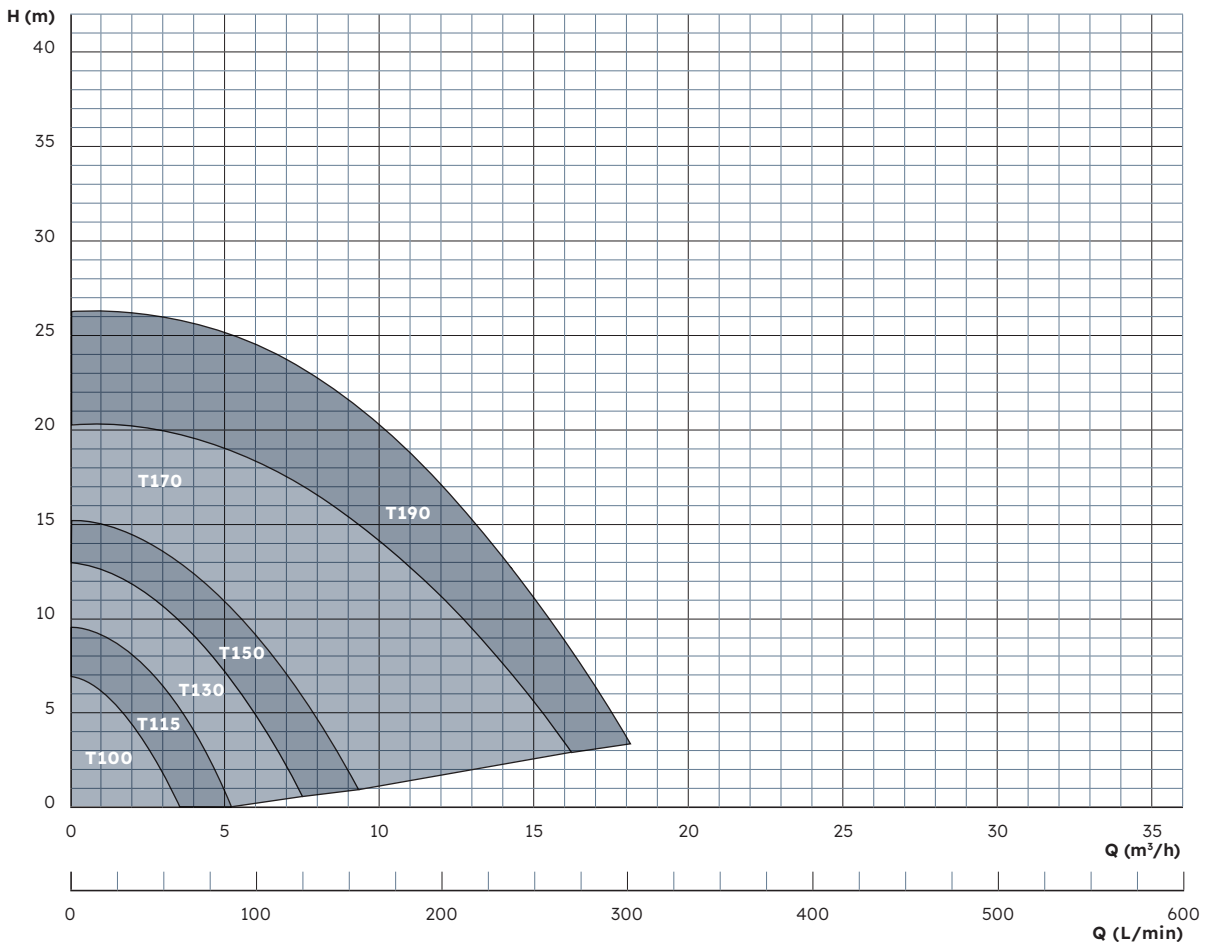

Sealless Vertical Centrifugal Pumps

Made of PVDF or PP, Dry-Run Safe

Advantages

- + Absolutely dry run safe because of contact-free shaft and impeller rotation
- + No abrasion into the fluid, therefore well suited for high-purity applications
- + Maintenance-free operation as no wearing parts such as slide bearings or mechanical seal

The pump can handle solids up to 3 mm in particle size at concentrations of up to 10 % by volume. Viscosity may be up to 150 mPa·s. The maximum permissible medium temperature is 95 °C, depending on the version.



High Purity

No wear particles are introduced into the pumped medium.

Low Maintenance

Maintenance-free due to sealless design.



Description

Characteristics

Non-metallic, chemical resistant, vertical sealless centrifugal pump, dry run safe

Features

- Absolutely dry run safe because of contact-free shaft and impeller rotation
- Maintenance-free operation as no wearing parts such as slide bearings or mechanical seals
- Available with extension tubes in different lengths to individually adjust the immersion depth
- Available with inlet strainer to prevent rough dirt and objects from entering the pump housing
- All wetted parts made of high-quality, corrosion-resistant plastics (PVDF or PP)
- Threaded connections (ISO 228-1) as standard
- Optionally available with flange connections (from size 130)
- Universally applicable, low-noise and compact close-coupled design
- Corrosion resistant motor finish

Fields of application

Installation in return vessels, tank tops, container lids, pump sumps, etc. Delivery of acids, bases, lye or other corrosive liquids.

Useful in applications, where dry running of the pump cannot be prevented at times.

For example in the following applications:

- Plating and surface coating
- Semiconductor technology and solar cell production
- PCB and electronics manufacturing
- Wastewater and fresh water treatment
- Laboratory equipment and medical technology
- Emission controls and gas scrubbers
- Battery production and energy storage
- High-purity applications, demineralized water, ultrapure water

Characteristics

Available materials

- Pump housing: PVDF, PP
- Elastomers: FKM, EPDM, FEP, FFKM

Standard motors

(available from stock)

- Three-phase motors: Δ 230/Y400 V, 3-ph @ 50 Hz; Y460 V, 3-ph @ 60 Hz; IP55, Class F, with PTC as standard
- All three-phase motors from 0.75 kW comply with energy efficiency class IE3
- Single-phase motors: up to 1.1 kW: 230 V, 1-ph, 50/60 Hz, IP55, Class F
- ATEX-certified motors (temperature rating T3)

Special motors

(on request)

- Special voltages and frequencies
- Three-phase motors with integrated frequency converter
- ATEX-certified motors with flameproof enclosure and temperature rating T4
- Four-pole motors with 1450 rpm @ 50 Hz / 1650 rpm @ 60 Hz
- UL- and CSA-certified motors
- Special types of protection, e.g., IP65
- Special insulation classes, e.g., tropical insulation
- Multi-voltage, e.g., Δ 220-290/Y380-500 V @ 50 Hz; Δ 220-332/Y380-575 V @ 60 Hz
- Direct-current motors (DC or BLDC)

Operating conditions

- Max. flow rate: up to 18 m³/h
- Max. delivery head: up to 26 m
- Liquid temperature: -5 to 95°C (PVDF), resp. 0 to 80°C (PP)
- Ambient temperature: -10 to 40°C, higher temperatures on request
- Pumps can be adapted to high-density liquids (up to 2.0)
- T series pumps can run dry for unlimited time (except special versions with shaft seals)



Performance Curves **T 100** (0.12 kW) / **T 115** (0.25 kW)

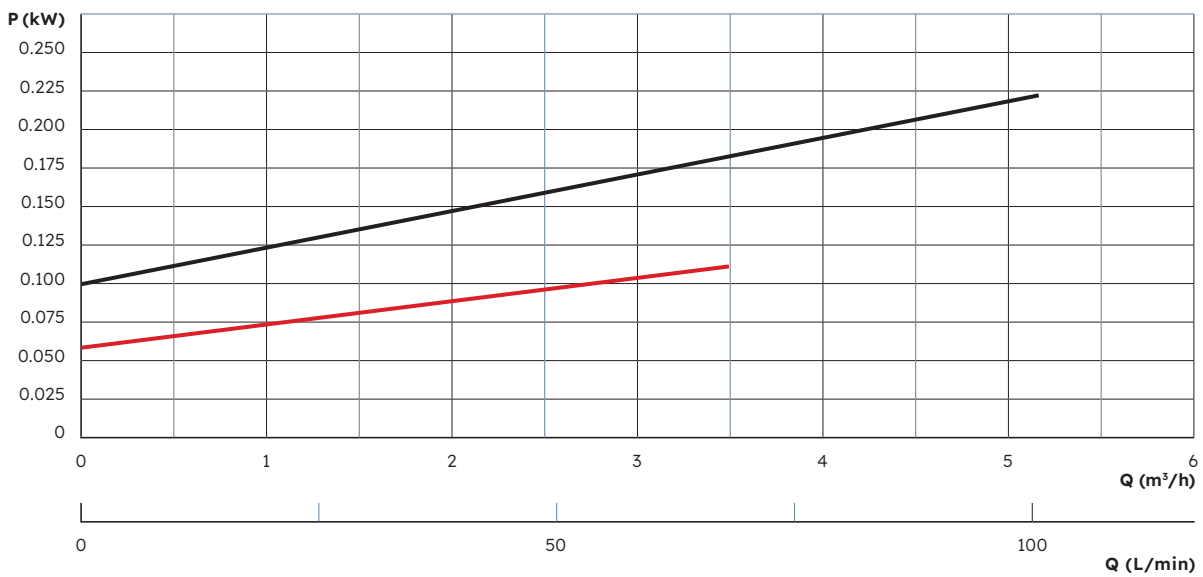
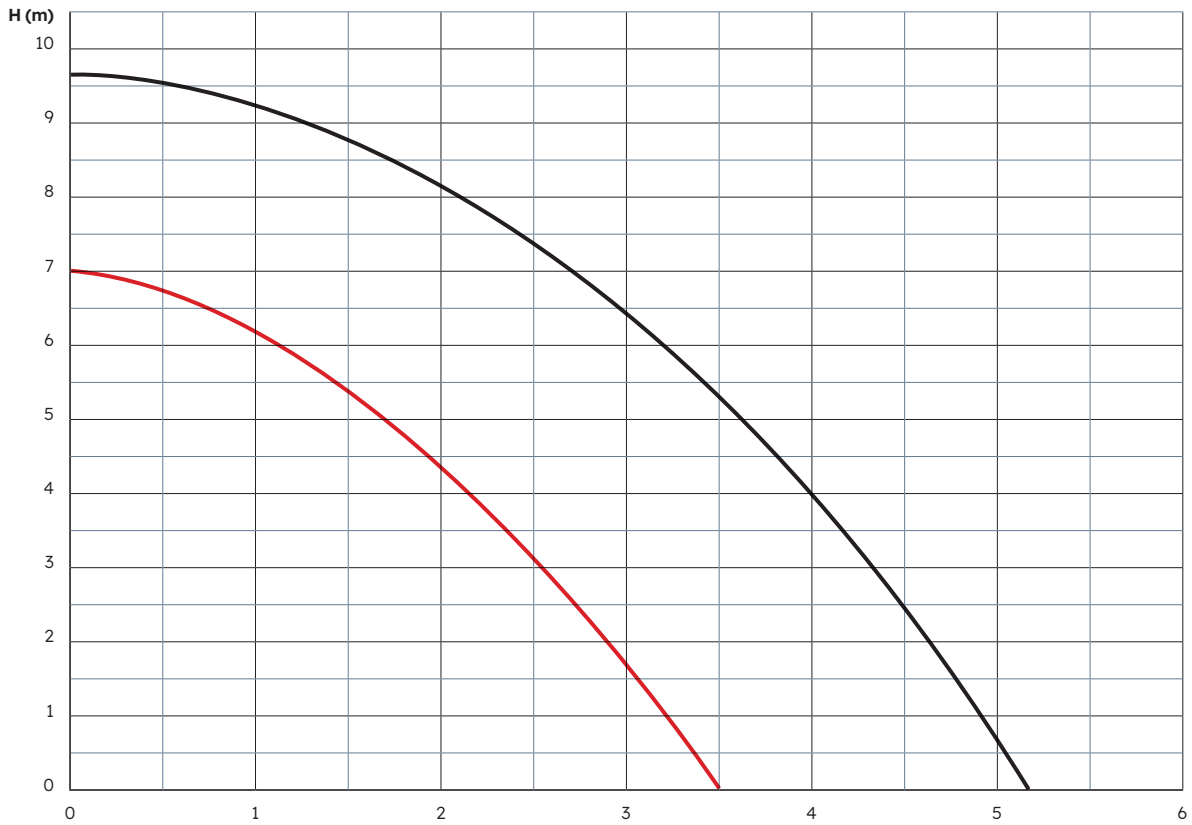

Performance Curves **T 130** (0.55 kW) / **T 150** (0.75 kW)

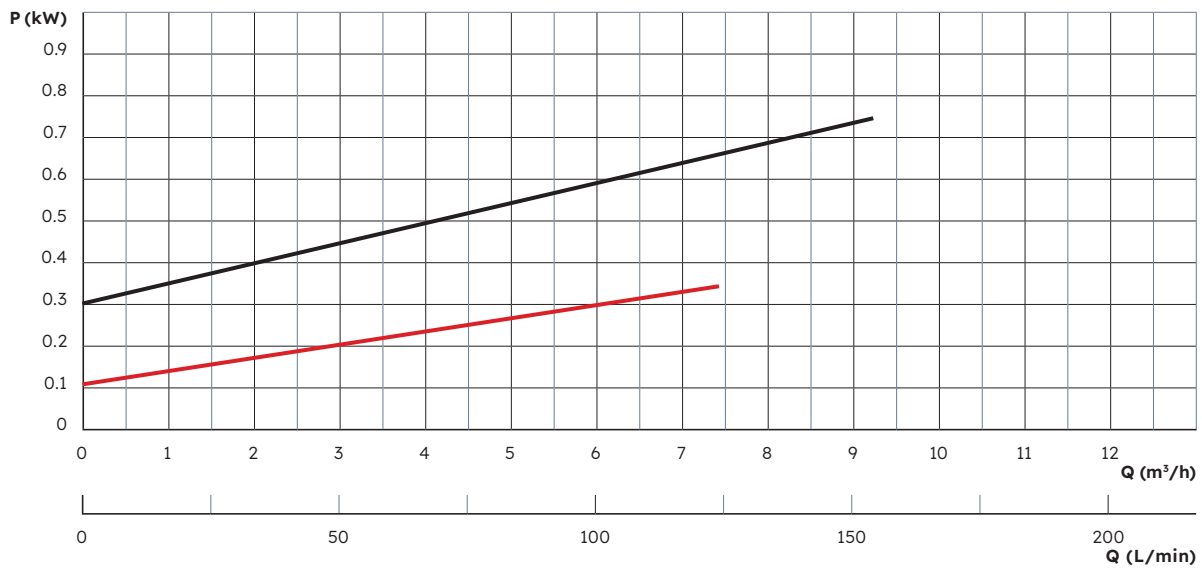



Performance Curve T 170 (1,5 kW)

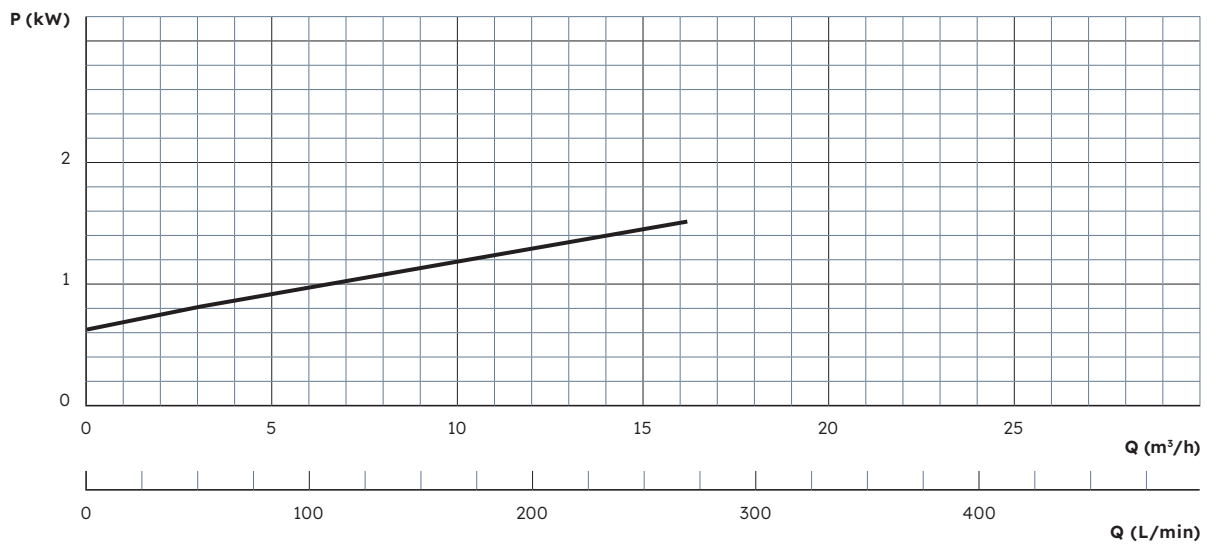
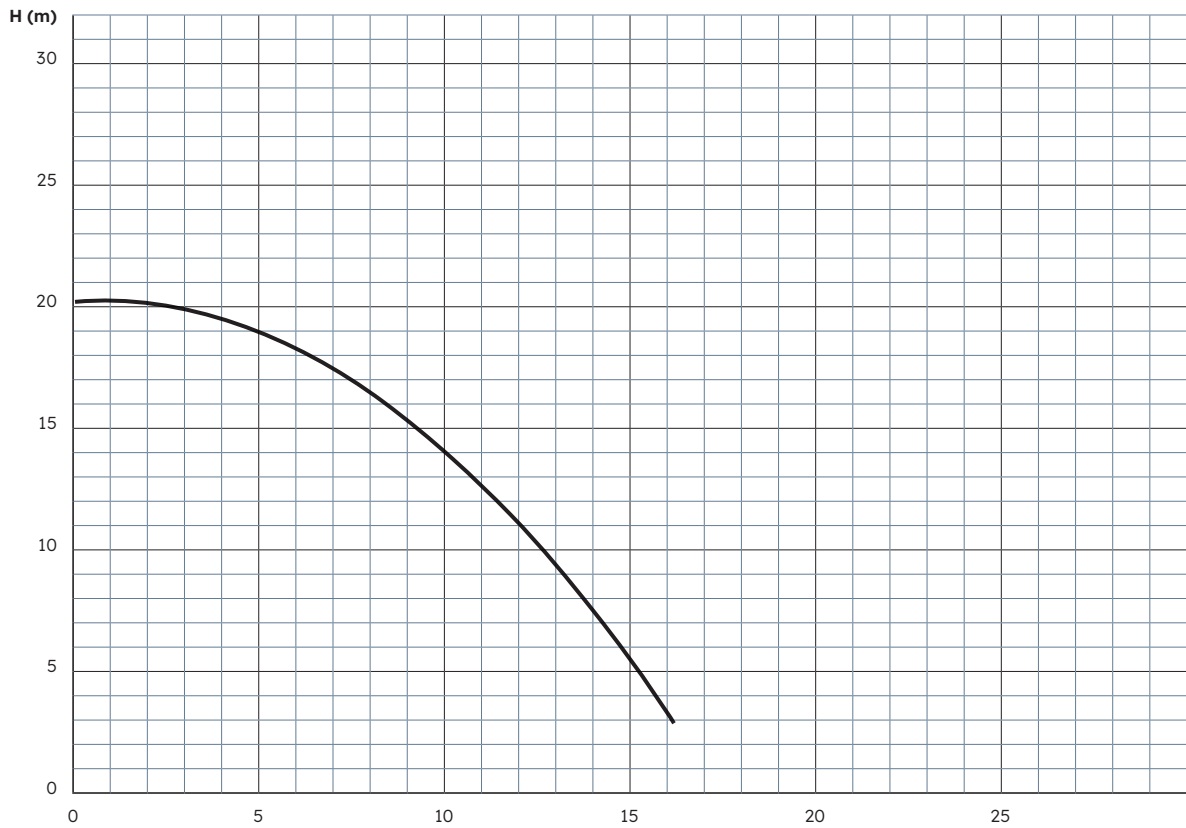

Performance Curve T 190 (2,2 kW)

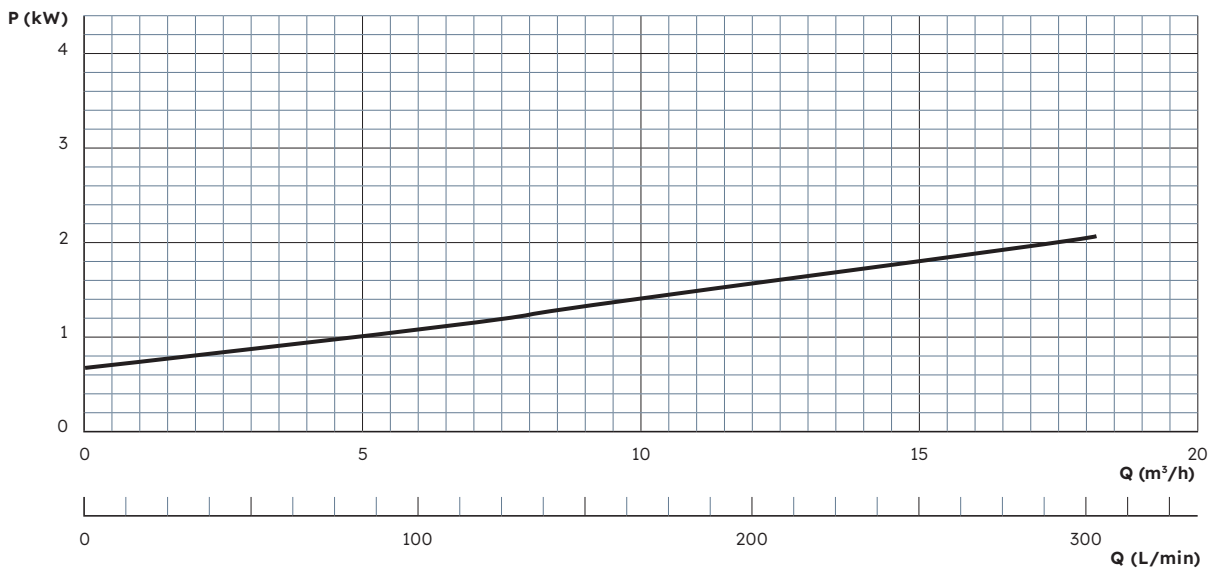

Dimensions

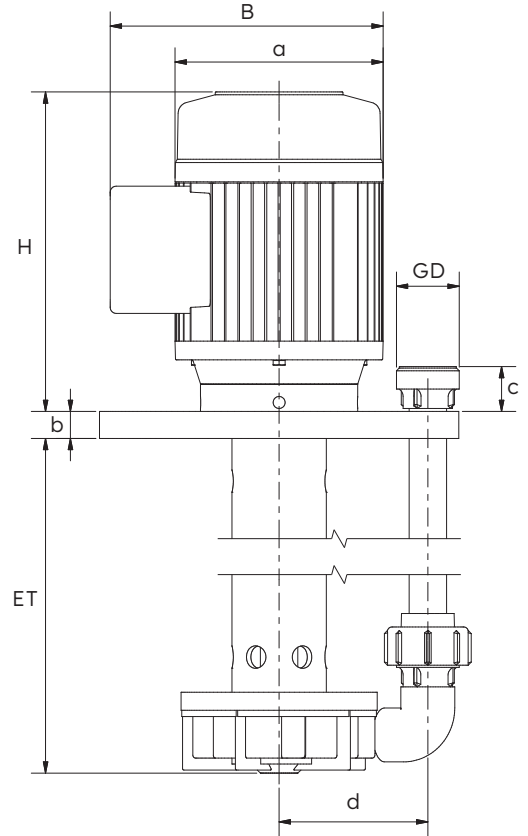
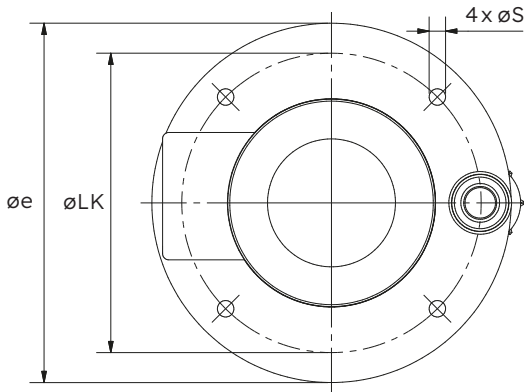

Type	Thread	DN	ET	B (mm)	H (mm)	LK (mm)	S (mm)	a (mm)	b (mm)	c (mm)	d (mm)	e (mm)
100	G1"	15	200	152	199	150	11	113	18	30	83	220
115	G1¼"	20	200 / 300 / 400	165	214	170	11	126	18	37	97	230
130	G1¼"	20	200 / 300 / 400	183	235	200	11	139	18	30	99	240
150	G1¼"	20	300 / 400 / 500	209	252	225	11	158	22	30	113	265
170	G1½"	25	400 / 600 / 800	230	305	280	13	175	22	55	130	320
190	G1½"	25	400 / 600 / 800	230	339	280	13	175	22	55	141	330

All dimensions are provided for reference purposes only and are subject to change without notice. Dimensional variations may occur depending on motor type, manufacturer, or configuration. A certified dimensional drawing will be supplied with the official quotation or order confirmation.

Fittings

A comprehensive range of accessories is available for all Schmitt pumps, facilitating seamless integration into your system:

- + Flange adapters
- + Hose connectors
- + Weld-on fittings for stainless steel piping
- + Reducers and expanders
- + NPT-threaded adaptors
- + Inlet strainers for vertical pumps
- + Extension pipes for vertical pumps

Spare Parts

Position	Description	Available materials
1	Motor	
2	Extension flange	PP
3	O-ring	FKM, EPDM, FEP, FFKM
4	Shaft, slotted pin, featherkey	Steel, stainless steel
5	Support tube	PP, PVDF
6	Cylinder screw, washer, nut	AISI 316
7	O-ring pressure side	FKM, EPDM, FEP, FFKM
8	Housing seal	FKM, EPDM, FEP, FFKM
9	Impeller with shaft sleeve	PP, PVDF
10	O-ring	FKM, EPDM, FEP, FFKM
11	Threaded cap	PP, PVDF
12	Pump housing	PP, PVDF
13	Hexagon bolt, nut, washer	PP, PVDF
14	O-ring	FKM, EPDM, FEP, FFKM

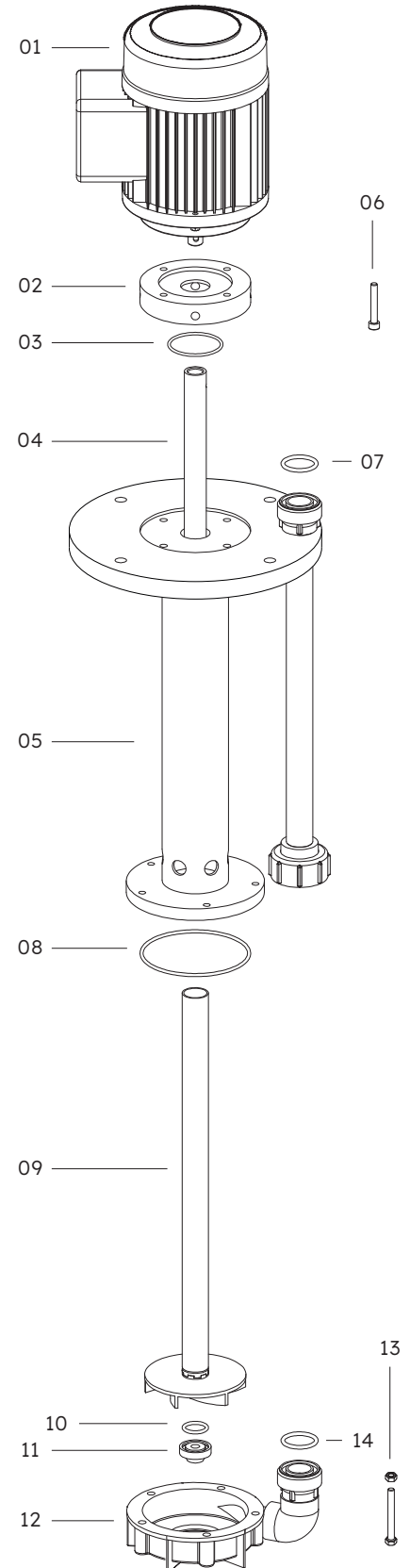

SCHMITT

Reinventing flow. Since 1964

NHM

Normal-Priming Centrifugal Pumps
Made of PVDF or PP with Magnetic Coupling



SCHMITT

Reinventing flow. Since 1964

MPN

Normal-Priming Centrifugal Pumps
Made of PVDF or PP with Magnetic Coupling



SCHMITT

Reinventing flow. Since 1964

U

Normal-Priming Centrifugal Pumps
Made of PVDF or PP with Single Mechanical Seal



SCHMITT

T

Sealless Vertical Centrifugal Pumps
Made of PVDF or PP Dry-Run Safe

Reinventing flow. Since 1964



SCHMITT

UP | UP-DO

Normal-Priming Centrifugal Pumps
Made of Stainless Steel with Single or Double Mechanical Seal

Reinventing flow. Since 1964



SCHMITT

Reinventing flow. Since 1964

SMP

Self-Priming Centrifugal Pumps
Made of PP with Magnetic Coupling



SCHMITT

Reinventing flow. Since 1964

P

Normal-Priming Turbine Pumps
Made of PVDF or PP with Magnetic Coupling



SCHMITT

NEOCHEM BASE

Standardized Chemical Pumps
ETFE-lined with Magnetic Coupling

Reinventing flow. Since 1964



SCHMITT

NEOCHEM CORE

Heavy-Duty Standardized Chemical Pumps
FFA-lined with Magnetic Coupling

Reinventing flow. Since 1964



SCHMITT-Kreiselpumpen GmbH & Co. KG
Einsteinstrasse 33
76275 Ettlingen, Germany
T +49 7243 5453-0
F +49 7243 5453-22
sales@schmitt-pumpen.de
schmitt-pumpen.de

