

# UP | UP-DO

**Normal-Priming Centrifugal Pumps**

Made of Stainless Steel with Single or Double Mechanical Seal

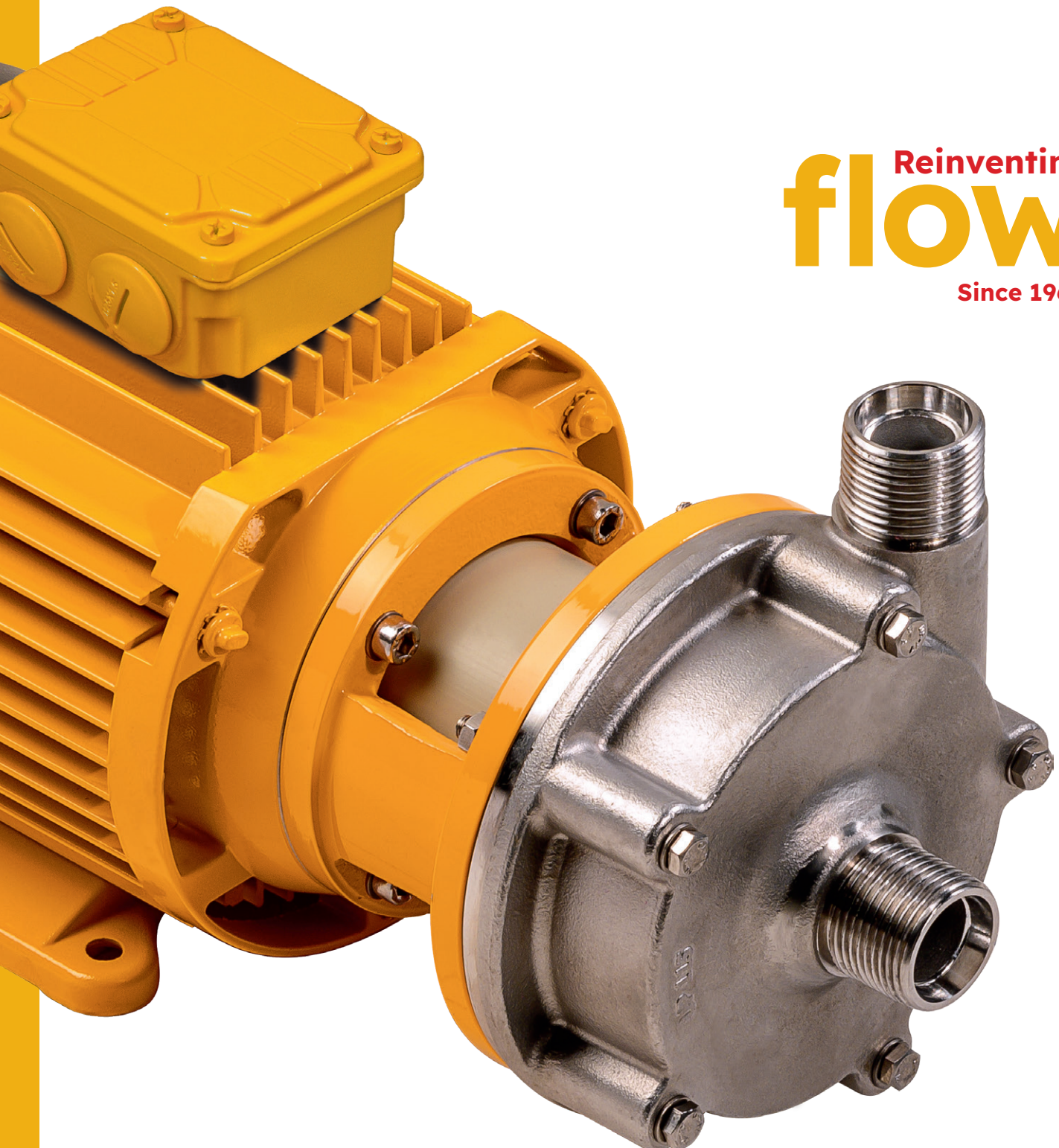

Reinventing  
**flow.**  
Since 1964

# UP|UP-DO

## Normal-Priming Centrifugal Pumps

Made of Stainless Steel with Single or Double Mechanical Seal

### Housing and impeller materials

Stainless steel 1.4571 (AISI 316Ti)

### Elastomers

EPDM, FKM (e.g. Viton®), FEP, FFKM (e.g. Kalrez®)

### Seal face material pairings

SiC / SiC, Carbon / SiC, Carbon / Al<sub>2</sub>O<sub>3</sub> ceramic

### Wetted metal parts

Stainless steel 1.4571 (AISI 316Ti)

The UP series is the counterpart to the U series for applications where the use of a thermoplastic pump is not feasible, for example due to elevated temperature requirements of up to 150 °C. It is equipped with a single mechanical seal, lubricated and cooled by the pumped medium. Optionally, this pump is also available with a double mechanical seal under the designation UP-DO. Seal faces and elastomers are available in various material options. The spring is made of Hastelloy® C-4.

## Performance Overview

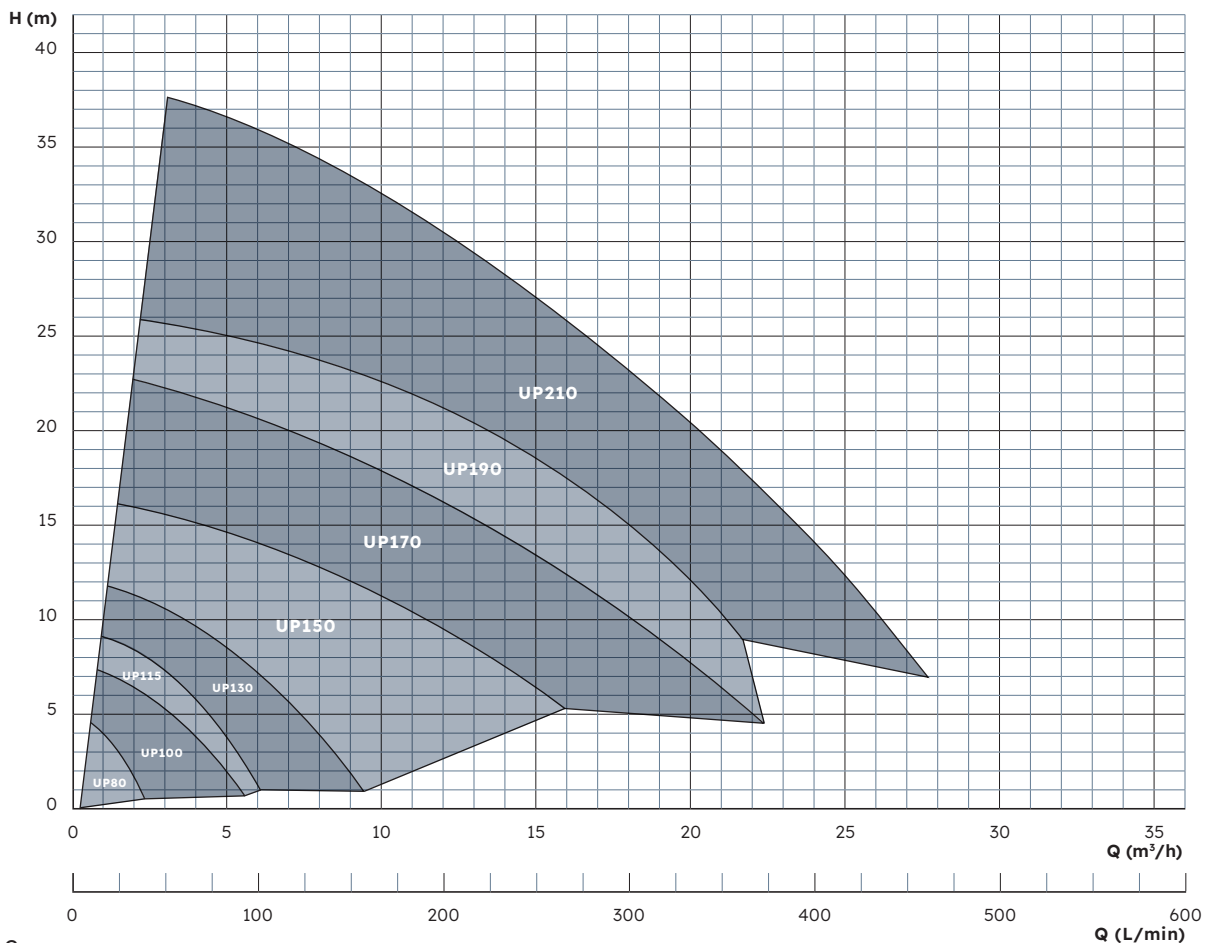

## Normal-Priming Centrifugal Pumps

Made of Stainless Steel with Single or Double Mechanical Seal

### Advantages

- + Robust housing parts with high wall thickness
- + Compact close-coupled design
- + Easy installation
- + Suitable for high temperatures
- + UP-DO: Dry run safe when using a pressurized seal support system
- + UP-DO: No leakage of toxic or environmentally hazardous liquids
- + UP-DO: Meets the requirements of the German TA Luft air pollution control regulation

The pump can handle solids up to 3 mm in particle size at concentrations of up to 10 % by volume. Viscosity may be up to 150 mPa·s. The maximum permissible medium temperature is 150 °C, depending on the version. All sizes are also available in ATEX-certified versions under the name UP-EX for ATEX zones 1 and 2.

### Thrives on Heat

Stays reliable at 150 °C. Solid cast construction — not thin sheet metal.



UP

## Description

### Characteristics

Stainless steel, chemical-resistant, single-stage centrifugal pump, closed-coupled design, with single or double mechanical seal

### Features

- Robust housing parts with high wall thickness
- Well suited to fluids containing solid particles due to spring-loaded mechanical seal
- Pumping of magnetic particles possible
- Low-maintenance-operation due to high-quality seal face materials
- All wetted parts made of high-quality, corrosion-resistant stainless steel 1.4571 (AISI 316 Ti)
- Threaded connections as per ISO 228-1 as standard. Optionally available with flange connections (from size 130)
- Universally applicable, low-noise and compact close-coupled design
- Approved for use in explosive atmospheres (Atex zone 1)
- Corrosion-resistant motor finish

### Fields of application

Delivery of seawater, weak acids, lye or other corrosive liquids at temperatures up to 150°C. For use in heavy-duty applications and harsh environments, where a robust pump is required.

#### **For example in the following applications:**

- Circulation of coolants and heat transfer oils in cooling or heating devices
- Electroplating and surface coating
- Wastewater and fresh water treatment
- Laboratory equipment and medical technology
- Environmental technology, emission control and gas scrubbers

## Characteristics

### Available materials

- Pump housing: Stainless steel 1.4571 (316Ti)
- Elastomers: FKM, EPDM, FFKM
- Seal face material pairings: SiC / SiC, Carbon / SiC, Carbon / Al<sub>2</sub>O<sub>3</sub> ceramic

### Standard motors

(available from stock)

- Three-phase motors: Δ230/Y400 V, 3-ph @ 50 Hz; Y460 V, 3-ph @ 60 Hz; IP55, Class F, with PTC as standard
- All three-phase motors from 0.75 kW comply with energy efficiency class IE3
- Single-phase motors: up to 1.1 kW: 230 V, 1-ph, 50/60 Hz, IP55, Class F
- ATEX-certified motors (temperature rating T3)

### Special motors

(on request)

- Special voltages and frequencies
- Three-phase motors with integrated frequency converter
- ATEX-certified motors with flameproof enclosure and temperature rating T4
- Four-pole motors with 1450 rpm @ 50 Hz / 1650 rpm @ 60 Hz
- UL- and CSA-certified motors
- Special types of protection, e.g., IP65
- Special insulation classes, e.g., tropical insulation
- Multi-voltage, e.g., Δ220-290/Y380-500 V @ 50 Hz; Δ220-332/Y380-575 V @ 60 Hz
- Direct-current motors (DC or BLDC)

### Operating conditions

- Flow rate up to 30 m<sup>3</sup>/h
- Maximum head up to 40 m
- Temperature: -20 to 150°C
- Ambient temperature from -10 up to 40°C, higher temperatures on request
- Pumps can be adapted to high-density liquids (up to 2.0)

# UP|UP-DO

## Performance Curves **UP 80** (0.18 kW) / **UP 100** (0.18 kW)

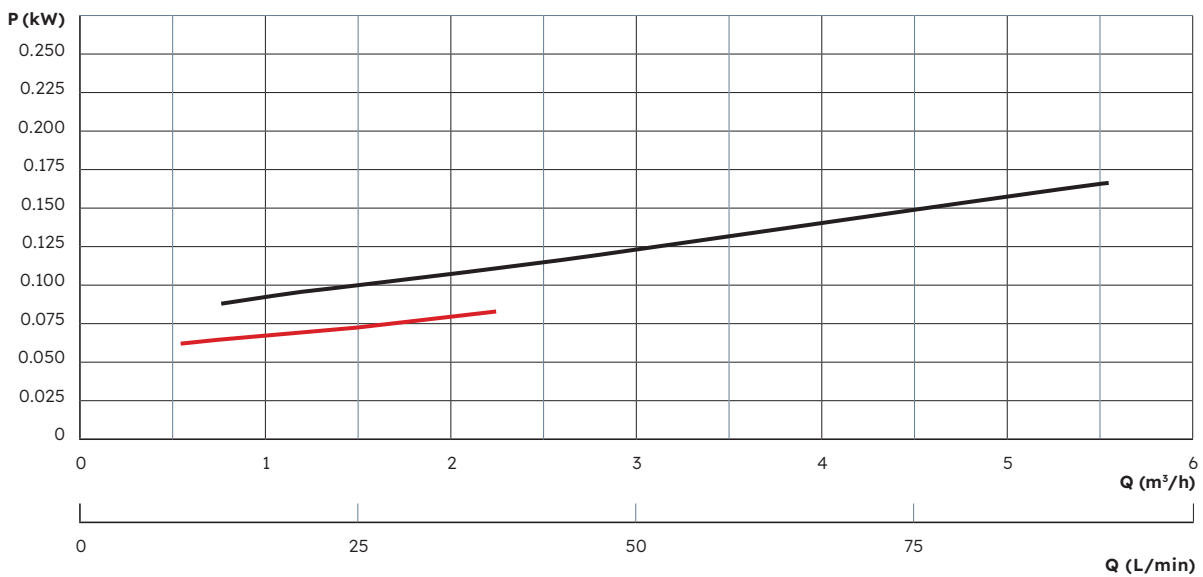

## Performance Curves **UP 115** (0.25 kW) / **UP 130** (0.55 kW)

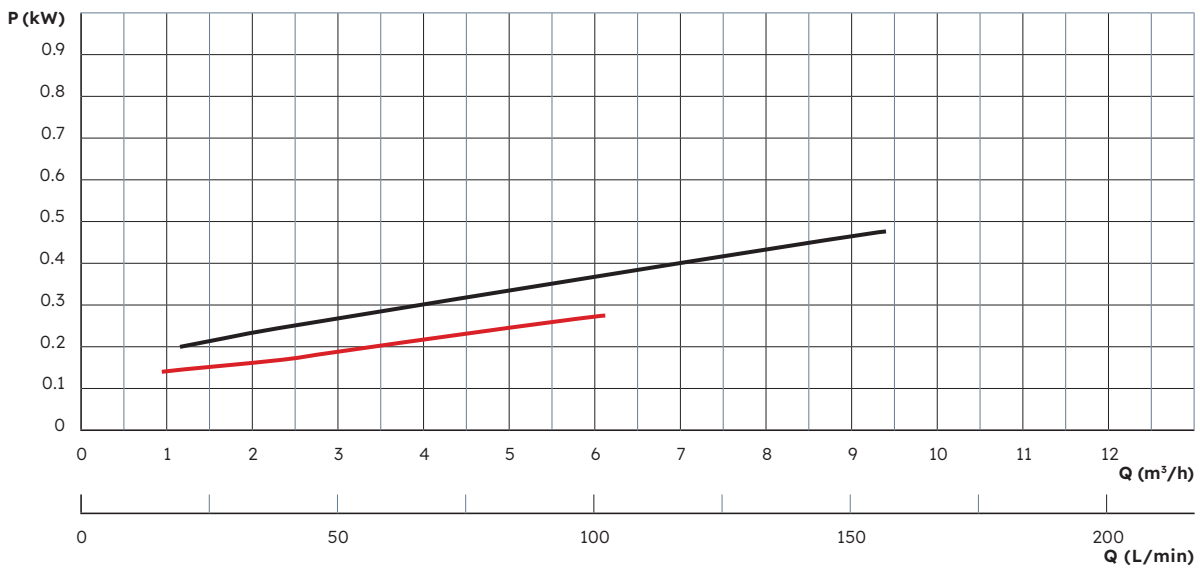

# UP|UP-DO

## Performance Curves **UP 150** (1.1 kW) / **UP 170** (2.2 kW)

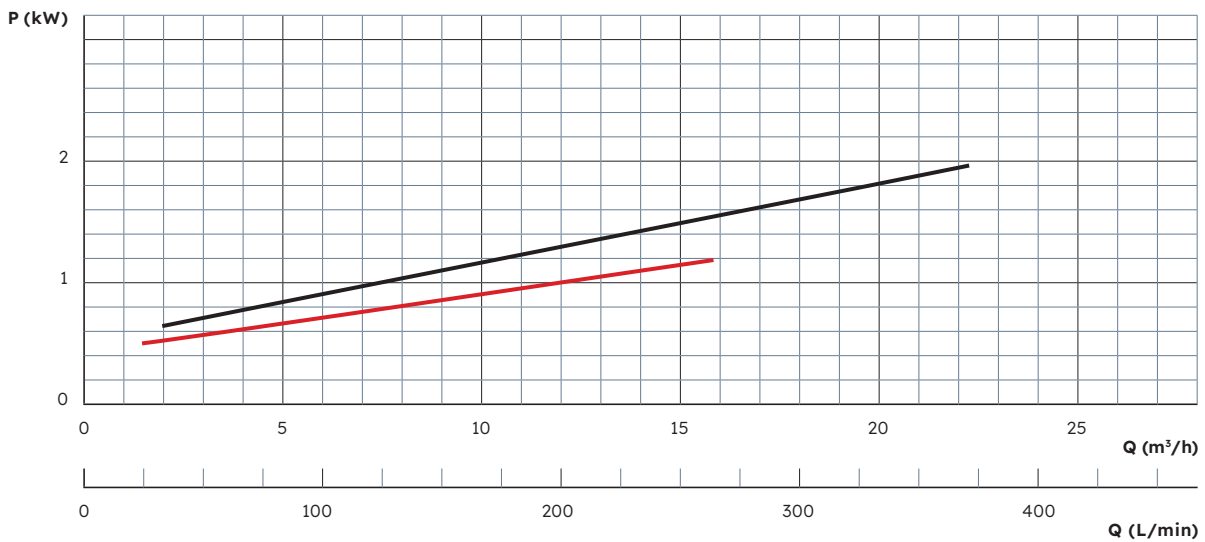
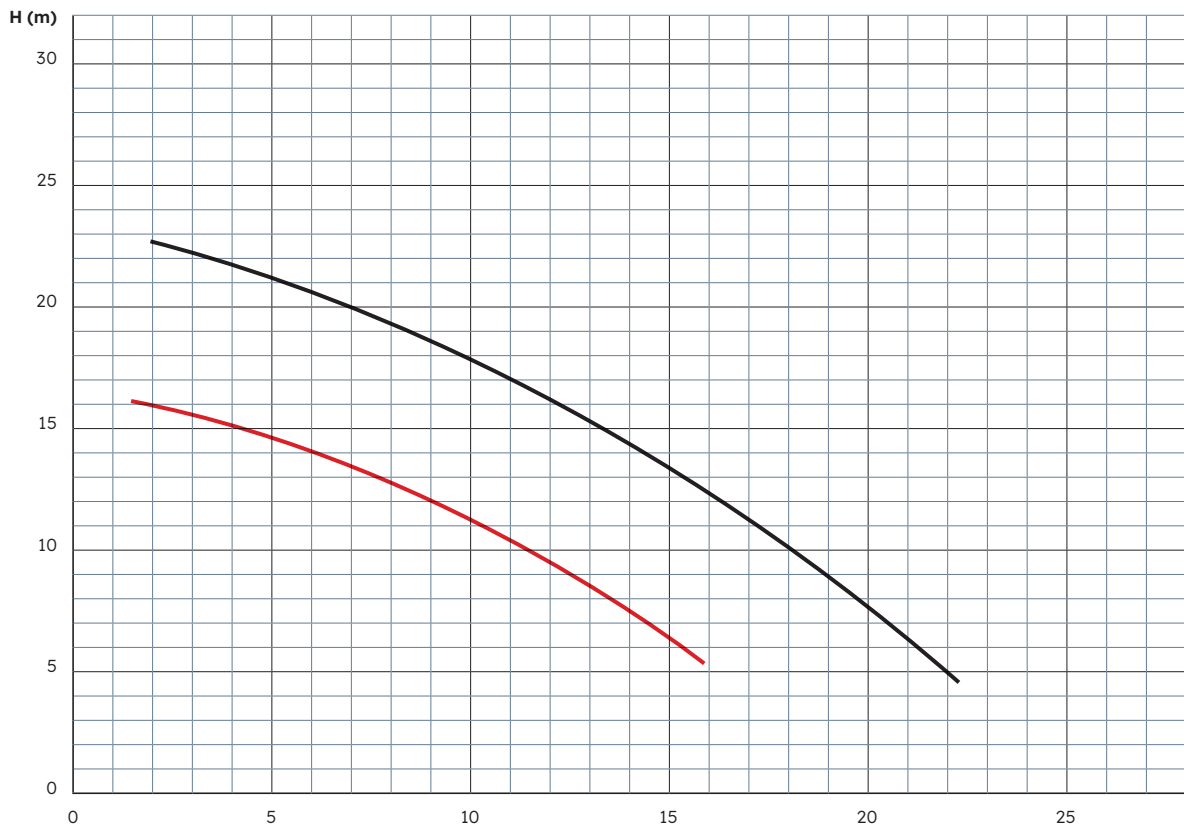

## Performance Curves **UP 190** (3.0 kW) / **UP 210** (5.5 kW)

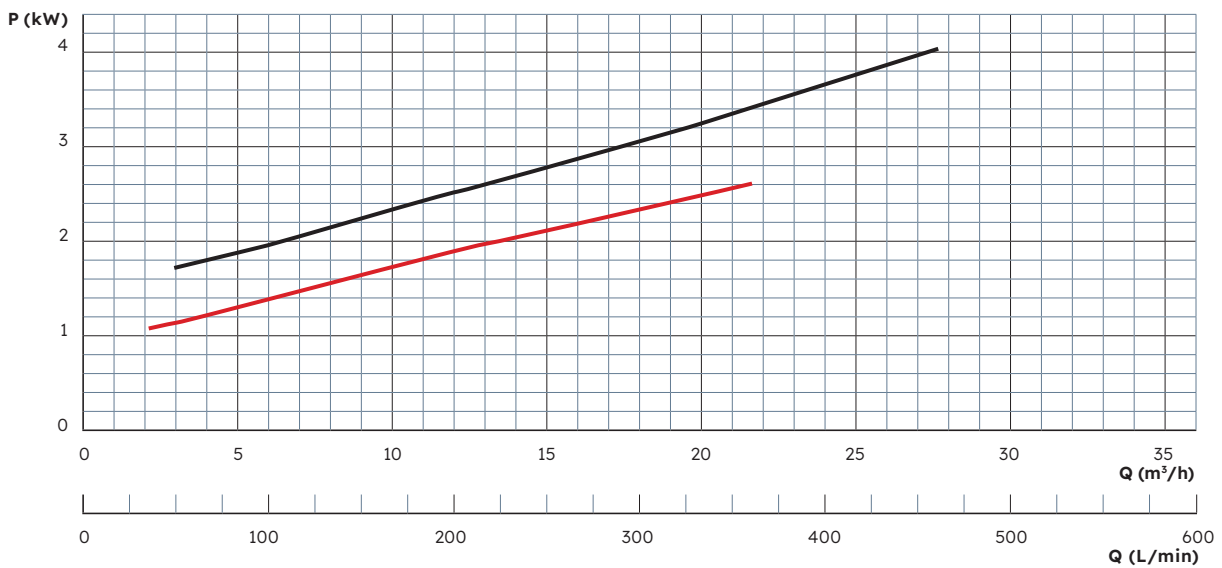

## Dimensions

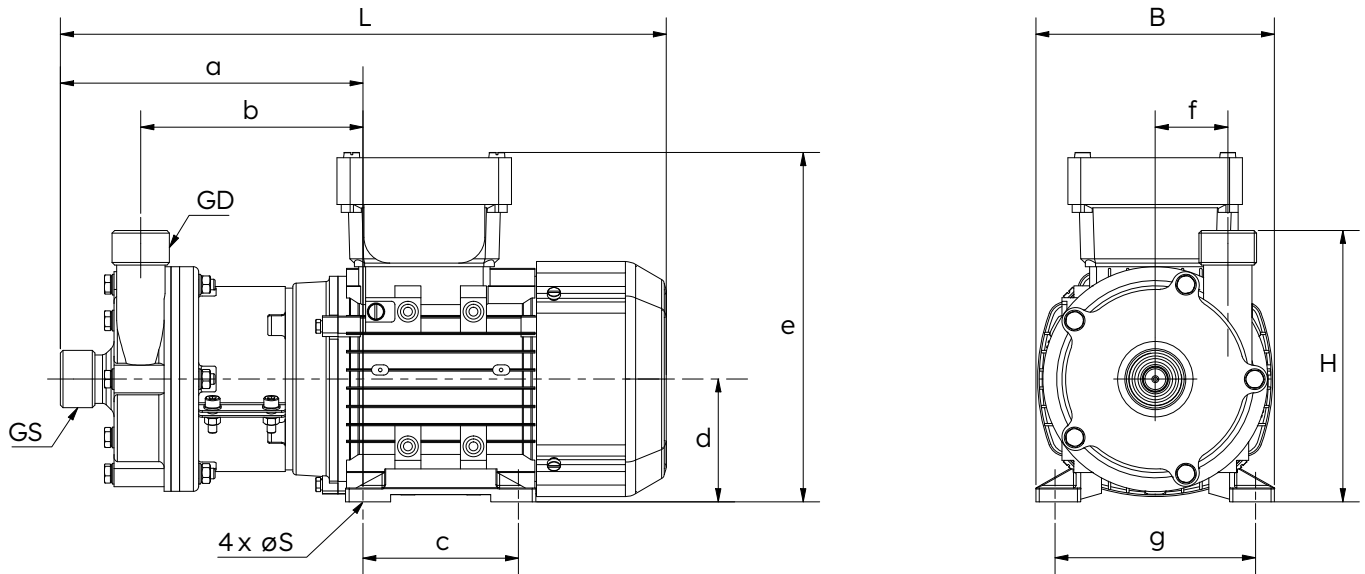

Typ	GS		GD		L (mm)	B (mm)	H (mm)	S (mm)	a (mm)	b (mm)	c (mm)	d (mm)	e (mm)	f (mm)	g (mm)
	Thread	DN	Thread	DN											
80	G½"	10	G½"	10	325	123	131	7	172	134	80	63	168	32	100
101	G¾"	15	G¾"	15	330	123	133	7	176	136	80	63	168	35	100
115	G¾"	15	G¾"	15	337	123	141	7	167	122	80	63	186	35	100
130	G1"	20	G1"	20	351	138	157	7	175	129	90	71	202	42	112
150	G1¼"	25	G1"	20	415	157	176	10	204	153	100	80	220	47	125
170	G1½"	32	G1¼"	25	473	173	200	10	234	175	125	90	191	55	140
191	G1½"	32	G1¼"	25	495	196	220	12	242	183	140	100	259	60	160
211	G2"	40	G1½"	32	517	227	242	12	253	189	140	112	304	70	190

All dimensions are provided for reference purposes only and are subject to change without notice. Dimensional variations may occur depending on motor type, manufacturer, or configuration. A certified dimensional drawing will be supplied with the official quotation or order confirmation.

## Fittings

A comprehensive range of accessories is available for all Schmitt pumps, facilitating seamless integration into your system:

- + Flange adapters
- + Hose connectors
- + Weld-on fittings for stainless steel piping
- + Reducers and expanders
- + NPT-threaded adaptors
- + Inlet strainers for vertical pumps
- + Extension pipes for vertical pumps

**Normal-Priming Centrifugal Pumps**  
Made of Stainless Steel with Single or Double Mechanical Seal

## Spare Parts

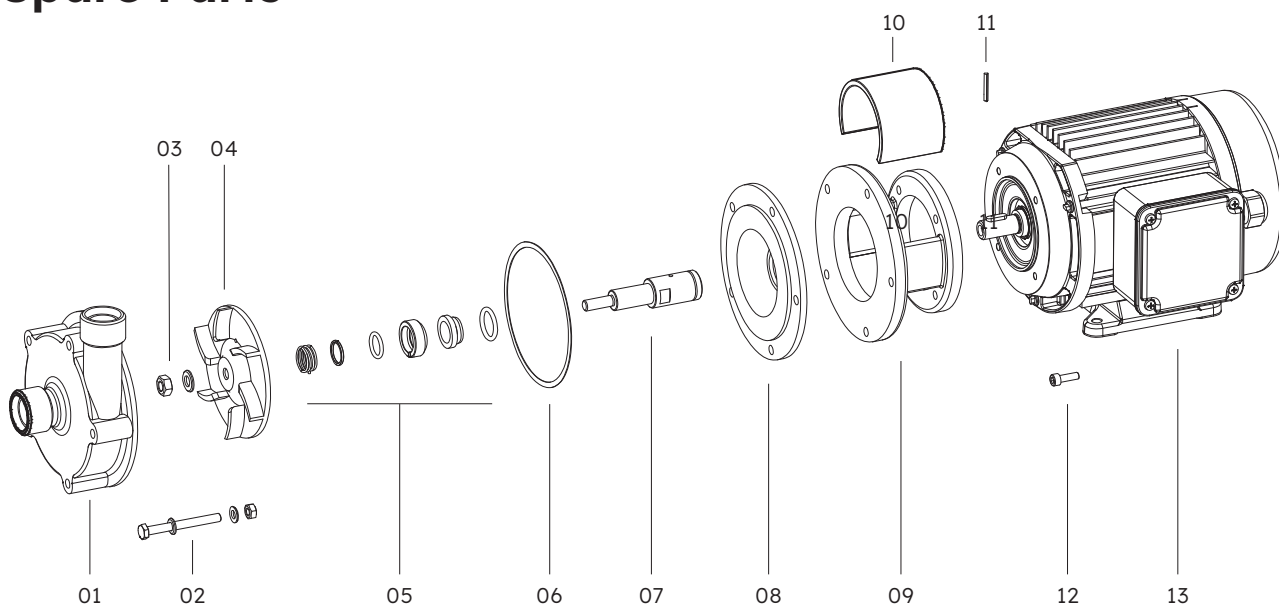

Position	Description	Available materials
01	Pump housing	Stainless steel 1.4571 / 316 Ti
02	Hexagon bolt, washer, nut	V4A
03	Locking nut, washer	V4A
04	Impeller	Stainless steel 1.4571 / 316 Ti
05	Mechanical seal	Various options
06	Housing seal	FKM, EPDM, PTFE, FFKM
07	Shaft	Stainless steel 1.4571 / 316 Ti
08	Backplate	Stainless steel 1.4571 / 316 Ti
09	Flange	Aluminium
10	Protection cover	PP
11	Slotted pin	V4A
12	Cylinder screw bolt	V4A

Remark: Spare parts list for UP-DO available on request

SCHMITT

Reinventing flow. Since 1964

# NHM

Normalausgange Kreiselpumpen aus PVDF oder PP mit Magnetkupplung



SCHMITT

Reinventing flow. Since 1964

# MPN

Normalausgange Kreiselpumpen aus PVDF oder PP mit Magnetkupplung



SCHMITT

Reinventing flow. Since 1964

# U

Normalausgange Kreiselpumpen aus PVDF mit einfach- oder doppelt- wählender Gleitringdichtung



SCHMITT

# T

Dichtunglose Einbaupumpen aus PP oder PVDF, trockenlaufender



Reinventing flow. Since 1964

SCHMITT

# UP | UP-DO

Normalausgange Kreiselpumpen aus Edelstahl mit einfach oder doppelt- wählender Gleitringdichtung

Reinventing flow. Since 1964



SCHMITT

Reinventing flow. Since 1964

# SMP

Selbstansaugende Kreiselpumpen aus PP mit Magnetkupplung



SCHMITT

Reinventing flow. Since 1964

# P

Normalausgange Peripherenrödpumpen aus PVDF oder PP mit Magnetkupplung



SCHMITT

# NEOCHEM BASE

Chemie-Normpumpen ETFE ausgekleidet, mit Magnetkupplung



Reinventing flow. Since 1964

SCHMITT

# NEOCHEM CORE

Heavy Duty-Chemie-Normpumpen PFA ausgekleidet, mit Magnetkupplung



Reinventing flow. Since 1964