

Reinventing  
**flow.**  
Since 1964

**U**

**Normal-Priming Centrifugal Pumps**  
Made of PVDF with Single Mechanical Seal

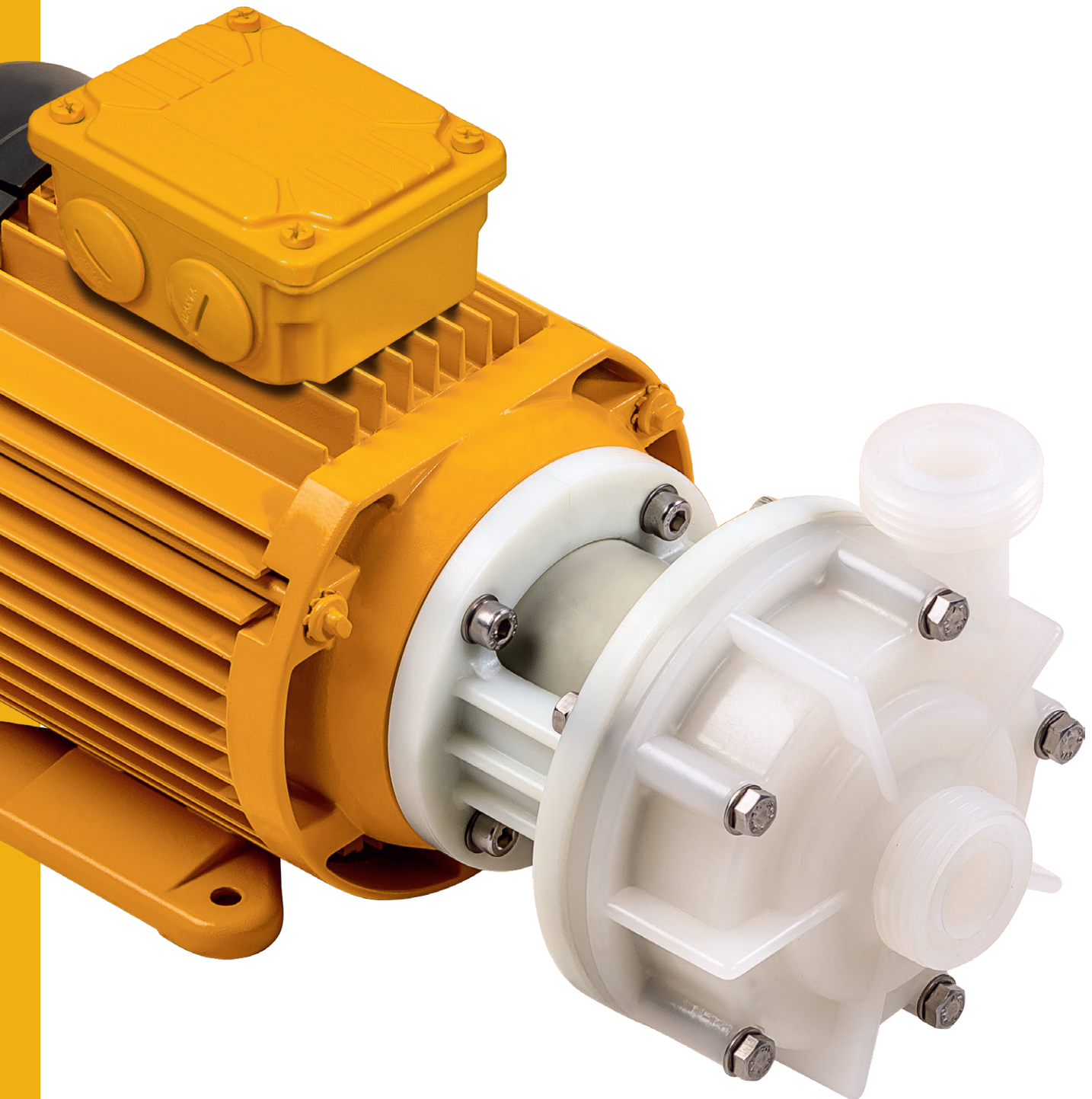



## Normal-Priming Centrifugal Pumps

Made of PVDF with Single Mechanical Seal

### Housing and impeller materials

PVDF

### Elastomers

EPDM, FKM (e.g. Viton®), FEP, FFKM (e.g. Kalrez®)

### Seal face material pairings

SiC / SiC, Carbon / SiC, Carbon / Al<sub>2</sub>O<sub>3</sub> ceramic

### Wetted metal parts

Stainless steel 1.4571 (AISI 316Ti), Hastelloy® C-4

The U series is Schmitt's entry-level pump range for handling corrosive media. The impeller is directly mounted on the extended motor shaft. The pump is equipped with a single mechanical seal, lubricated and cooled by the pumped fluid. The seal is available in various configurations, with different elastomer and seal face materials, as well as an optional PVDF shaft sleeve.

## Performance Overview

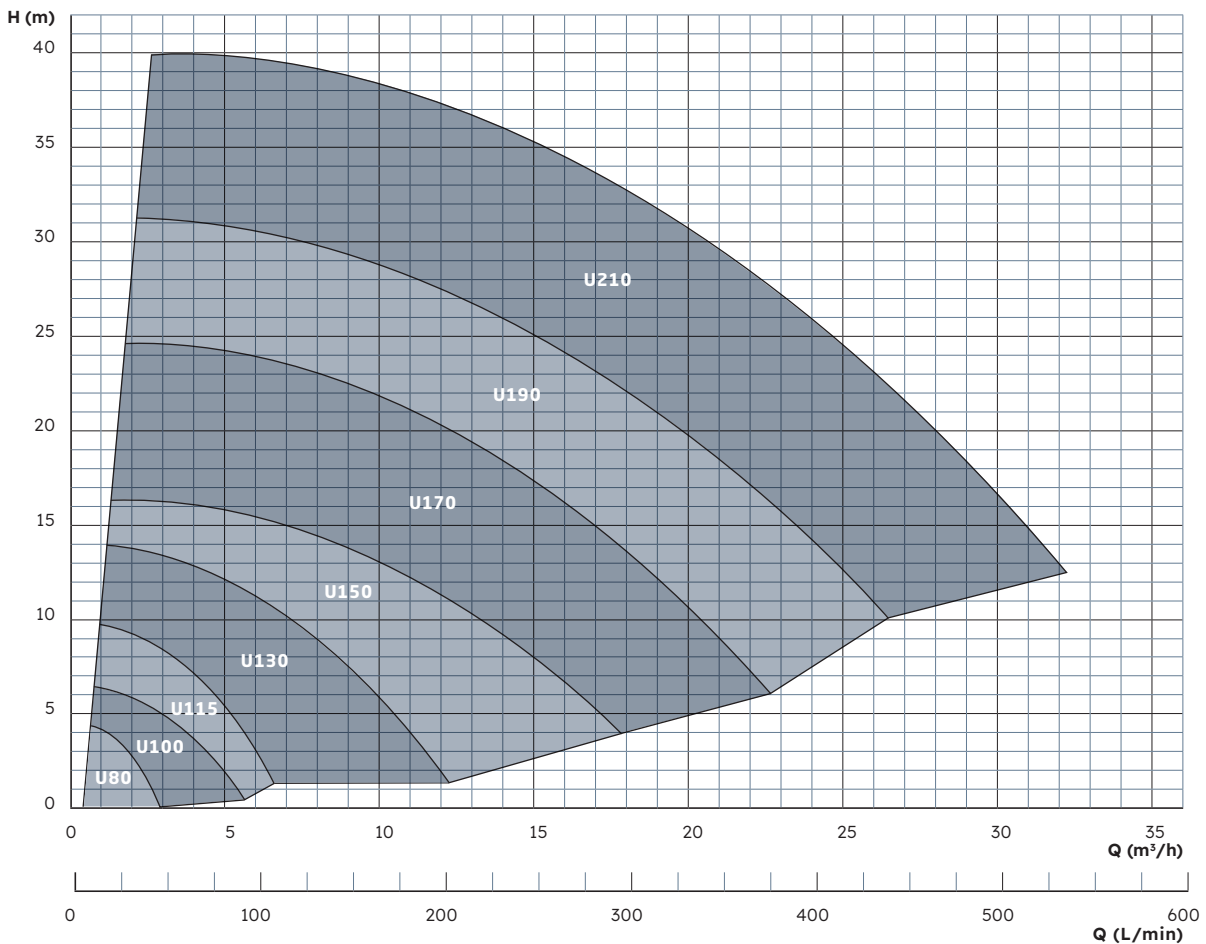

## Normal-Priming Centrifugal Pumps

Made of PVDF with Single Mechanical Seal

### Advantages

- + Economical and robust alternative to magnetic drive pumps
- + Suitable for pumping media containing magnetic particles
- + Compact close-coupled design
- + Designed for corrosive media

The U series is a true all-rounder, engineered for a broad spectrum of applications. Multiple design variants and material options allow precise adaptation to a wide range of operating conditions. The pump can handle solids up to 3 mm in size and concentrations of up to 10 % by volume. Maximum viscosity: 150 mPa·s. Maximum permissible temperature: 95 °C. All sizes are also available in ATEX-certified versions (U-EX) for use in ATEX Zone 2.

#### All-Round Talent

Proven long service life. Low upfront investment.

#### Perfectly Configurable

Seals, mechanical seal options, sizes – the range of possible configurations = U: unlimited.

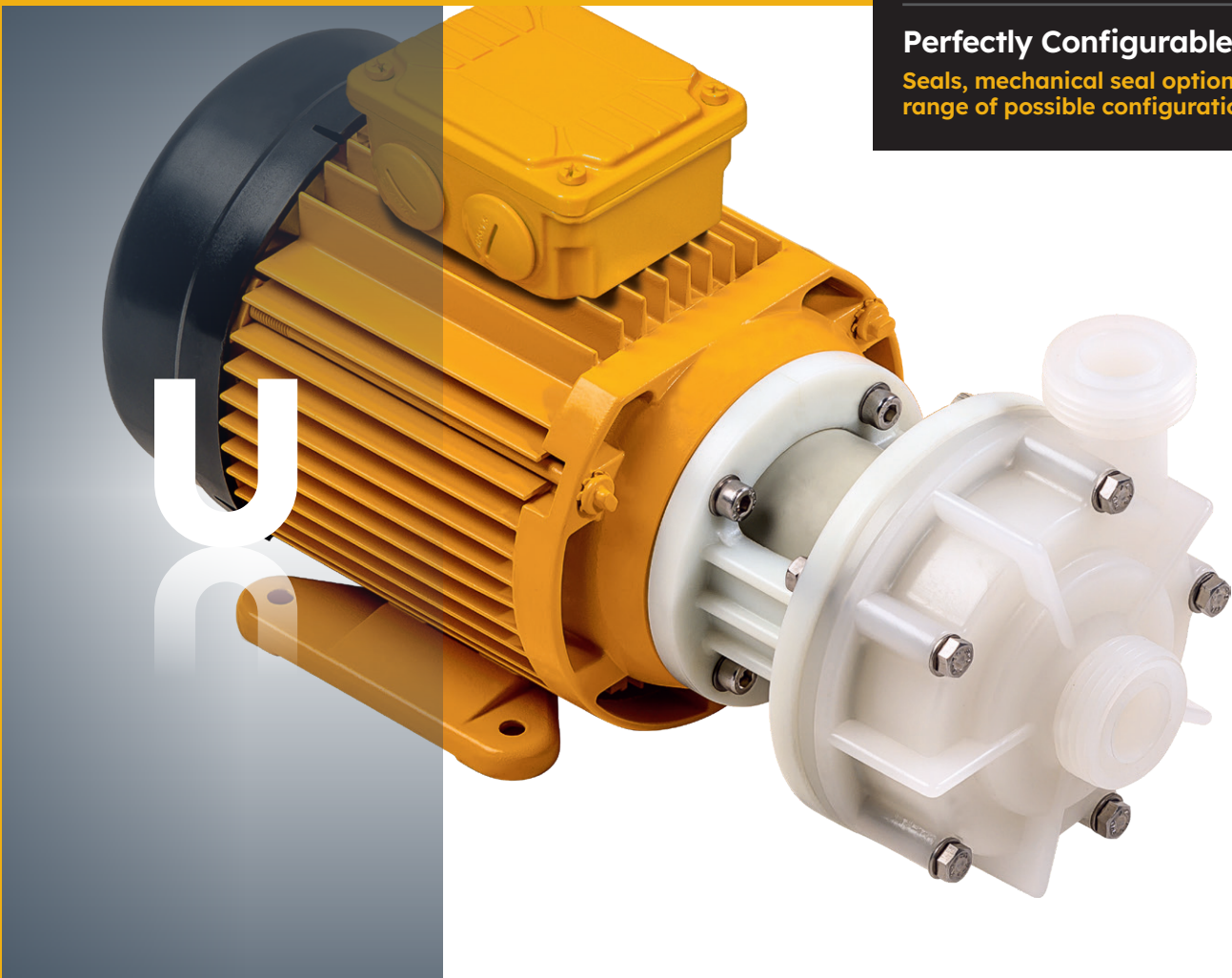



## Description

### Characteristics

Non-metallic, chemical-resistant, single-stage centrifugal pump, with single mechanical seal

### Features

- Economic and robust alternative to magnetic drive pumps
- Well-suited for solid-containing fluids due to spring-loaded mechanical seal
- Pumping of magnetic particles possible
- Low-maintenance-operation due to high-quality seal face materials
- All wet parts made of high-quality, corrosion-resistant materials
- Threaded connections (ISO 228-1) as standard
- Available with flange connections from size 130
- Universally applicable, low-noise and compact close-coupled design

### Fields of application

Delivery of acids, bases or other corrosive liquids in such applications, where a hermetically sealed pump is not required. Delivery of acids and bases or other corrosive liquids containing low to medium amounts of solid particles.

#### **For example in the following applications:**

- Plating and surface coating
- Semiconductor technology and solar cell production
- PCB and electronics manufacturing
- Wastewater and fresh water treatment
- Laboratory equipment and medical technology
- Emission controls and gas scrubbers
- Battery production and energy storage
- High-purity applications, demineralized water, ultrapure water

## Characteristics

### Available materials

- Pump housing: PVDF
- Elastomers: FKM, EPDM, FEP, FFKM
- Seal face material pairings: SiC / SiC, Carbon / SiC, Carbon / Al<sub>2</sub>O<sub>3</sub> ceramic

### Standard motors

(available from stock)

- Three-phase motors: Δ230/Y400 V, 3-ph @ 50 Hz; Y460 V, 3-ph @ 60 Hz; IP55, Class F, with PTC as standard
- All three-phase motors from 0.75 kW comply with energy efficiency class IE3
- Single-phase motors: up to 1.1 kW: 230 V, 1-ph, 50/60 Hz, IP55, Class F
- ATEX-certified motors (temperature rating T3)

### Special motors

(on request)

- Special voltages and frequencies
- Three-phase motors with integrated frequency converter
- ATEX-certified motors with flameproof enclosure and temperature rating T4
- Four-pole motors with 1450 rpm @ 50 Hz / 1650 rpm @ 60 Hz
- UL- and CSA-certified motors
- Special types of protection, e.g., IP65
- Special insulation classes, e.g., tropical insulation
- Multi-voltage, e.g., Δ220-290/Y380-500 V @ 50 Hz; Δ220-332/Y380-575 V @ 60 Hz
- Direct-current motors (DC or BLDC)

### Operating conditions

- Flow rate up to: 30 m<sup>3</sup>/h
- Maximum head up to 40 m
- Liquid temperature: -5 to 95°C (PVDF)
- Ambient temperature from -10 up to 40°C, higher temperatures on request
- Pumps can be adapted to high-density liquids (up to 2)



## Performance Curves **U 80** (0.18 kW) / **U 101** (0.18 kW)

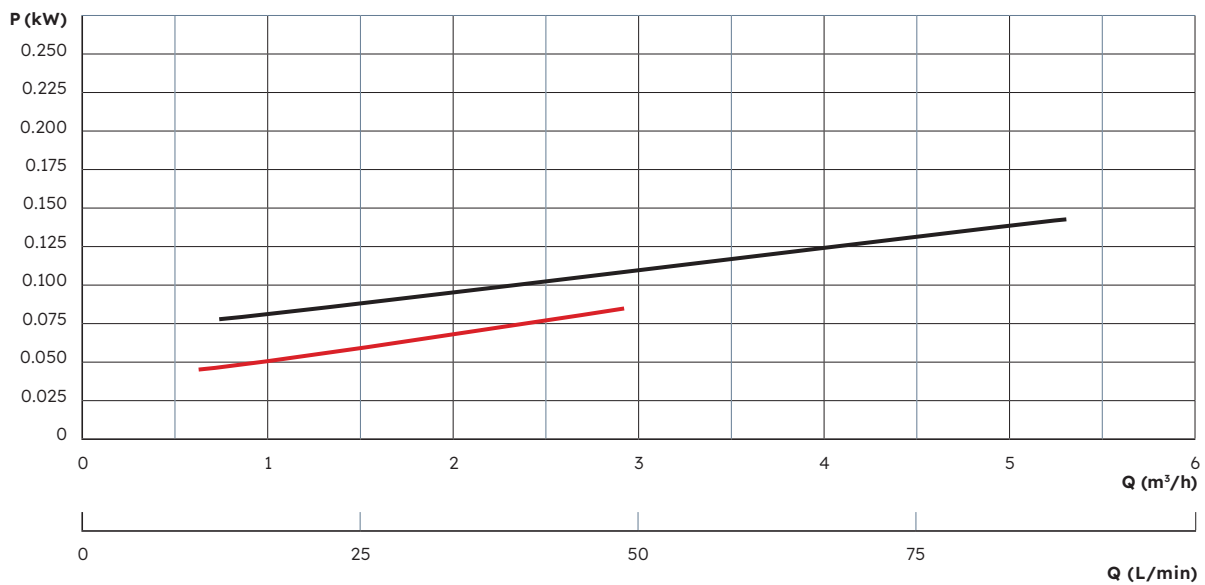

## Performance Curves **U 115** (0.25 kW) / **U 130** (0.55 kW)

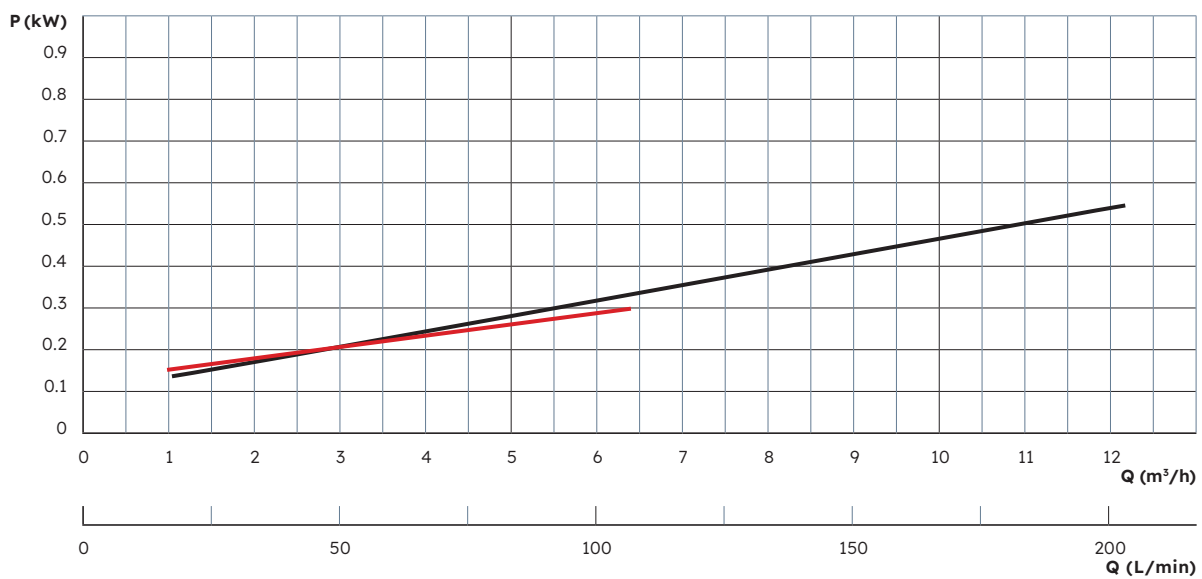



## Performance Curves **U 150** (1.1 kW) / **U 170** (2.2 kW)

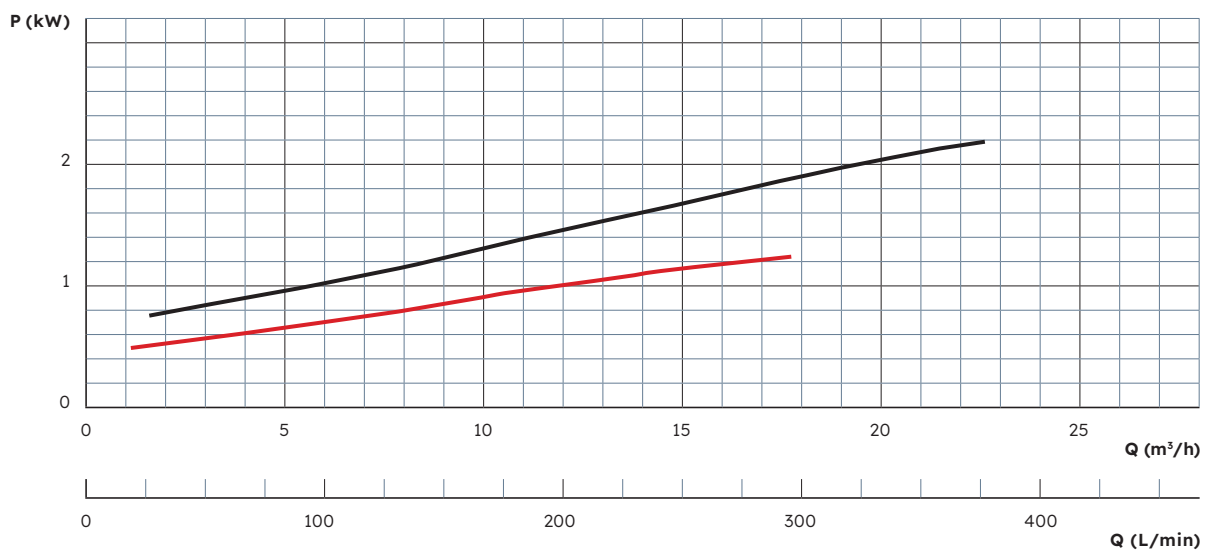

## Performance Curves **U 190** (3.0 kW) / **U 210** (5.5 kW)

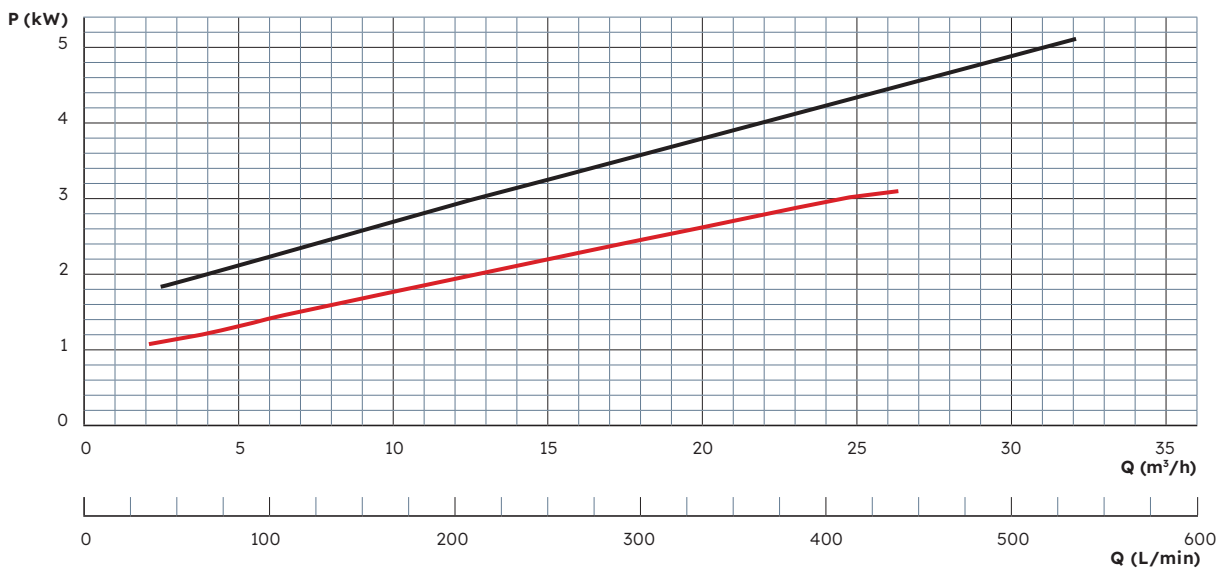
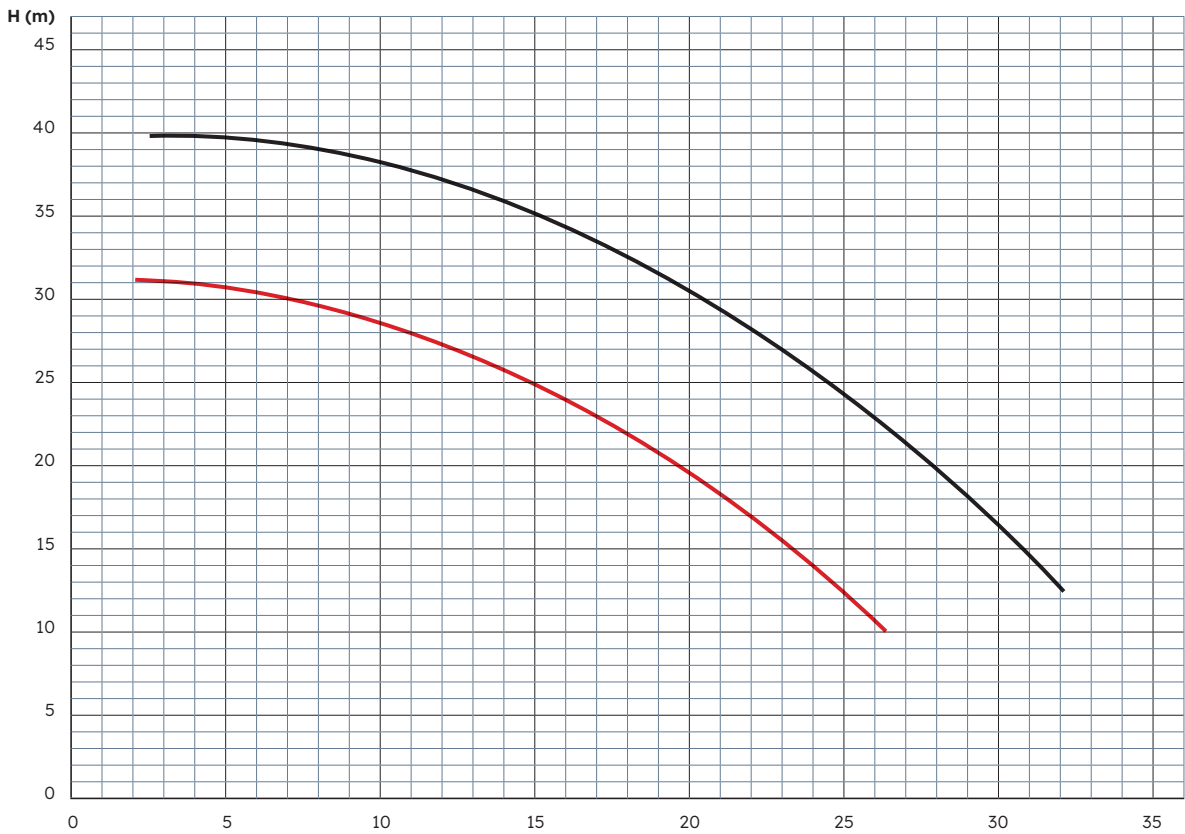



## Dimensions

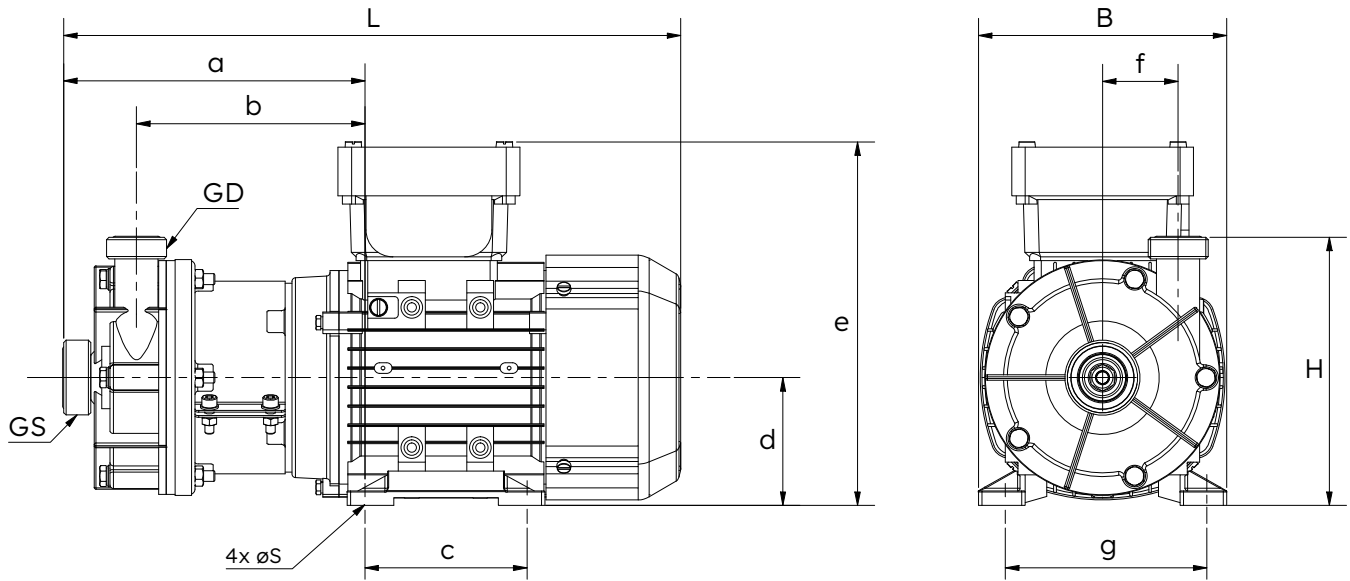

Typ	GS		GD		L (mm)	B (mm)	H (mm)	S (mm)	a (mm)	b (mm)	c (mm)	d (mm)	e (mm)	f (mm)	g (mm)
	Thread	DN	Thread	DN											
80	G¾"	10	G¾"	10	317	123	115	7	163	128	80	63	168	25	100
101	G1"	15	G1"	15	324	123	125	7	170	135.5	80	63	168	31	100
115	G1"	15	G1"	15	329	123	134	7	159	122	80	63	186	37	100
130	G1¼"	20	G1"	15	344	138	149	7	168	128	90	71	202	42	112
150	G1½"	25	G1¼"	20	411	157	171	10	200	152	100	80	220	47	125
170	G2"	32	G1½"	25	467	173	245	10	228	175	125	90	191	59	140
190	G2"	32	G1½"	25	496	196	211	12	244	185	140	100	259	66	160
210	G2¼"	40	G2"	32	505	227	236	12	242	193	140	112	304	74	190

All dimensions are provided for reference purposes only and are subject to change without notice. Dimensional variations may occur depending on motor type, manufacturer, or configuration. A certified dimensional drawing will be supplied with the official quotation or order confirmation.

## Fittings

A comprehensive range of accessories is available for all Schmitt pumps, facilitating seamless integration into your system:

- + Flange adapters
- + Hose connectors
- + Weld-on fittings for stainless steel piping
- + Reducers and expanders
- + NPT-threaded adaptors
- + Inlet strainers for vertical pumps
- + Extension pipes for vertical pumps

**Normal-Priming Centrifugal Pumps**  
Made of PVDF with Single Mechanical Seal

## Spare Parts

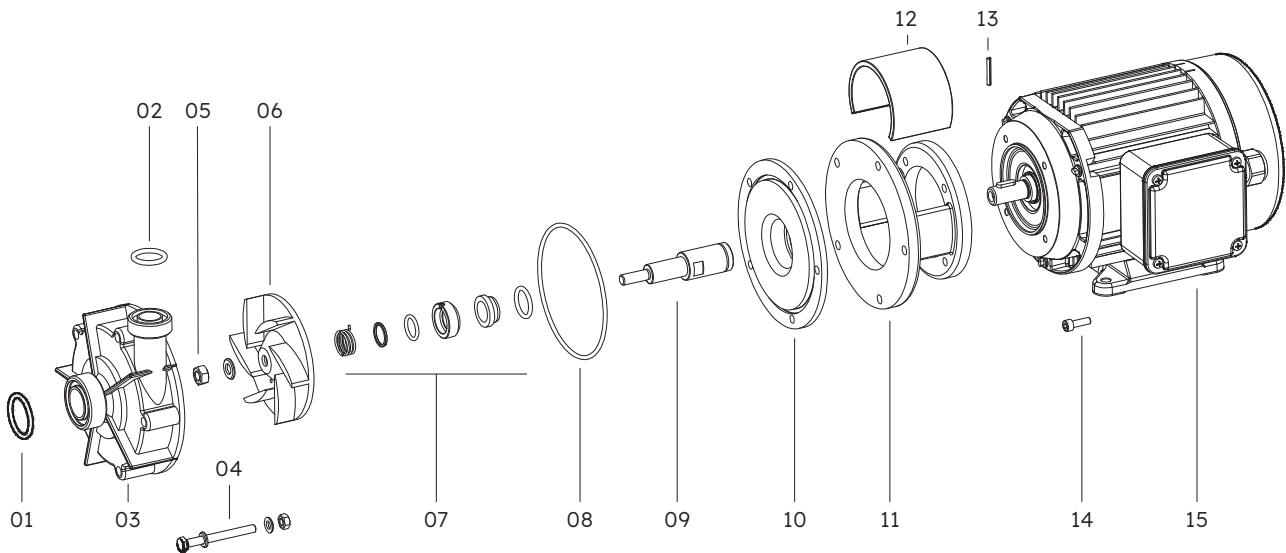

Position	Description	Available materials
01	O-ring (inlet port)	FKM, EPDM, FEP, FFKM
02	O-ring (outlet port)	FKM, EPDM, FEP, FFKM
03	Pump housing	PVDF
04	Hexagon bolt, washer, nut	V4A
05	Locking nut, washer	V4A, Hastelloy C4
06	Impeller	PVDF
07	Mechanical seal	Various options
08	Housing seal	FKM, EPDM, FFKM
09	Shaft	Stainless steel 1.4571 / 316Ti, Hastelloy C4
10	Backplate	PVDF
11	Flange	PP, aluminium
12	Protection cover	PP
13	Slotted pin	V4A
14	Cylinder bolt	V4A
15	Motor	

SCHMITT

Reinventing flow. Since 1964

**NHM**  
Normal-Priming Centrifugal Pumps  
Made of PVDF or PP with Magnetic Coupling



SCHMITT

Reinventing flow. Since 1964

**MPN**  
Normal-Priming Centrifugal Pumps  
Made of PVDF or PP with Magnetic Coupling



SCHMITT

Reinventing flow. Since 1964

**U**  
Normal-Priming Centrifugal Pumps  
Made of PVDF or PP with Single Mechanical Seal



SCHMITT

Reinventing flow. Since 1964

**T**  
Sealless Vertical Centrifugal Pumps  
Made of PVDF or PP Dry-Run Safe



SCHMITT

Reinventing flow. Since 1964

**UP | UP-DO**  
Normal-Priming Centrifugal Pumps  
Made of Stainless Steel with Single or Double Mechanical Seal



SCHMITT

Reinventing flow. Since 1964

**SMP**  
Self-Priming Centrifugal Pumps  
Made of PP with Magnetic Coupling



SCHMITT

Reinventing flow. Since 1964

**P**  
Normal-Priming Turbine Pumps  
Made of PVDF or PP with Magnetic Coupling



SCHMITT

Reinventing flow. Since 1964

**NEOCHEM BASE**  
Standardized Chemical Pumps  
ETFE-lined with Magnetic Coupling



SCHMITT

Reinventing flow. Since 1964

**NEOCHEM CORE**  
Heavy-Duty Standardized Chemical Pumps  
FFA-lined with Magnetic Coupling



SCHMITT-Kreiselpumpen GmbH & Co. KG  
Einsteinstrasse 33  
76275 Ettlingen, Germany  
T +49 7243 5453-0  
F +49 7243 5453-22  
sales@schmitt-pumpen.de  
schmitt-pumpen.de

