

Pillow block bearings with split housing:
KSTM-GT

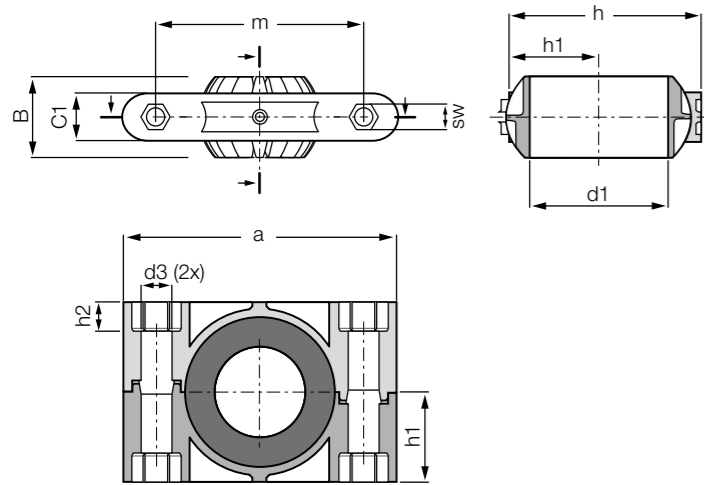

Order key

Type	Size [mm]	Version
------	-----------	---------

K S T M - G T 40 - G T

K series	Pillow block bearing	Metric	Split housing	Inner Ø	Split ball
-----------------	----------------------	--------	---------------	---------	------------

i Material:
Housing: RN33 ▶ Page 1657
Spherical ball: iglidur® J ▶ Page 159

m Service life calculation online
▶ www.igus.eu/igus-expert

- Low installation space and lightweight
- High stiffness and durability
- Predictable service life
- Dimensional K series according to DIN ISO 12240

- Fitting is easy and does not require shaft removal
- Maintenance-free, dry operation
- For high static loads
- Mounting: M12

Technical data

Part No.	Max. radial tensile/compressive strength		Max. axial tensile/compressive strength		Max. tightening torque through ball fixing holes		Weight [g]
	Short-term	Long-term	Short-term	Long-term	[Nm]	[Nm]	
	[N]	[N]	[N]	[N]			
KSTM-GT35 ²³⁾	11,000	5,500	2,500	1,250	5	15	250.3
KSTM-GT40	11,000	5,500	2,500	1,250	5	15	235.0
KSTM-GT40-GT ²⁴⁾	11,000	5,500	2,500	1,250	5	15	235.0
KSTM-GT45 ²³⁾	15,000	7,500	3,000	1,500	5	20	405.2
KSTM-GT50	15,000	7,500	3,000	1,500	5	20	389.2
KSTM-GT50-GT ²⁴⁾	15,000	7,500	3,000	1,500	5	20	389.2

Dimensions [mm]

Part No.	d1	d3	h	h1	h2	SW	a	m	C1	B	Max. pivot angle
KSTM-GT35 ²³⁾	35.0	13.5	79.0	39.5	12.6	19.0	120.5	91.0	29.5	48.5	24°
KSTM-GT40	40.0	13.5	79.0	39.5	12.6	19.0	120.5	91.0	29.5	48.5	24°
KSTM-GT40-GT ²⁴⁾	40.0	13.5	79.0	39.5	12.6	19.0	120.5	91.0	29.5	48.5	24°
KSTM-GT45 ²³⁾	45.0	13.5	100.0	50.0	12.6	19.0	149.0	114.0	35.0	60.0	24°
KSTM-GT50	50.0	13.5	100.0	50.0	12.6	19.0	149.0	114.0	35.0	60.0	24°
KSTM-GT50-GT ²⁴⁾	50.0	13.5	100.0	50.0	12.6	19.0	149.0	114.0	35.0	60.0	24°

²³⁾ Diameter reduced by plain bearing; ²⁴⁾ Split housing and split ball

794 Online tools and more information ▶ www.igus.eu/pillow-block



Pillow block bearings: ESTM

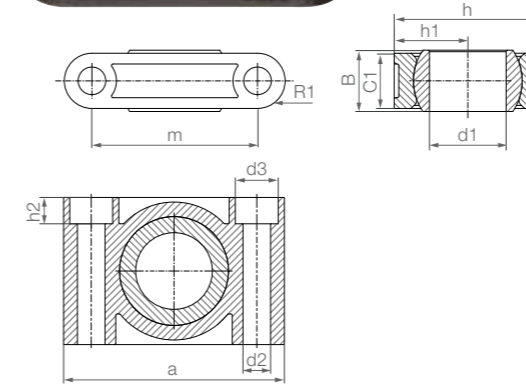

Order key

Type	Size [mm]
------	-----------

E S T M - 08

E series	Pillow block bearing	Metric	Inner Ø
-----------------	----------------------	--------	---------

i Material:
Housing: igumid G ▶ Page 1654
Spherical ball: iglidur® W300 ▶ Page 171
Combination with xiros® ball bearings
▶ From page 934

- High radial loads
- Media-resistant
- Space-saving design, easy to fit
- Predictable service life
- Maintenance and lubrication-free

- Dimensional E series according to DIN ISO 12240
- Adapter available ▶ Accessories, page 862

Technical data

Part No.	Max. radial tensile force		Max. radial compressive strength		Max. axial strength		Max. tightening torque fixing holes [Nm]	Weight [g]
	Short-term [N]	Long-term [N]	Short-term [N]	Long-term [N]	Short-term [N]	Long-term [N]		
	ESTM-08	2,500	1,250	4,300	2,150	600		
ESTM-10	3,400	1,700	5,300	2,650	700	350	2.5	7.1
ESTM-12	4,500	2,250	6,500	3,250	750	375	2.5	9.0
ESTM-16	6,700	3,350	8,500	4,250	1,100	550	4.5	17.5
ESTM-20	8,500	4,250	11,000	5,750	1,400	700	4.5	27.4
ESTM-25	13,500	6,750	18,500	9,250	2,300	1,150	10.5	50.8
ESTM-30 ²⁵⁾	10,000	5,000	16,500	8,250	2,500	1,250	10.5	79.7

²⁵⁾ Lower values loads due to different manufacturing method

Dimensions [mm]

Part No.	d1, E10	d2	d3	h	h1	h2	a	m	C1	B	R1	Max. pivot angle
ESTM-08	8	4.5	-	19	9.5	-	31	22	9	8	4.5	22°
ESTM-10	10	5.5	-	22	11.0	-	36	26	10	9	5.0	22°
ESTM-12	12	5.5	-	26	13.0	-	38	28	10	10	5.0	22°
ESTM-16	16	6.6	10.6	34	17.0	6.4	50	37	13	13	6.5	22°
ESTM-20	20	9.0	14.0	40	20.0	8.6	62	46	16	16	8.0	22°
ESTM-25	25	9.0	14.0	48	24.0	8.6	72	54	18	20	9.0	20°
ESTM-30	30	11.0	17.0	56	28.0	10.6	86	64	22	22	11.0	20°

Alternative spherical ball materials ▶ Page 841



3D CAD files, prices and delivery time online ▶ www.igus.eu/pillow-block 795