

EPF

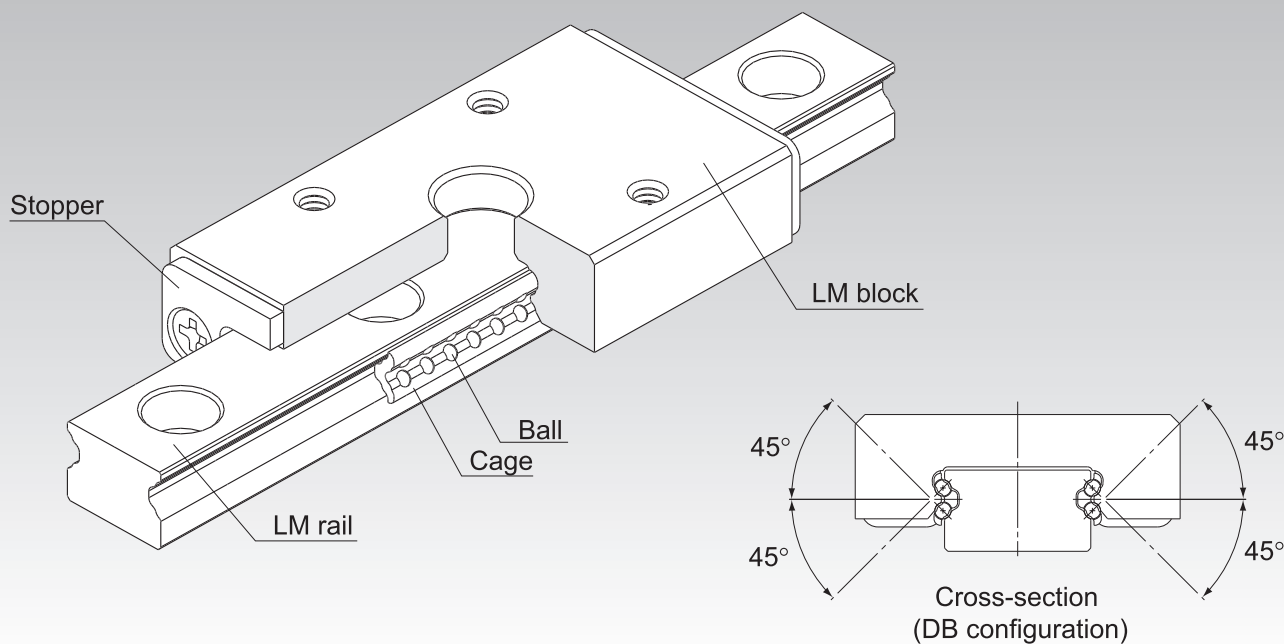

Caged Ball LM Guide Finite stroke Model EPF



*For the ball cage, see **A1-90**.

Point of Selection	A1-10
Point of Design	A1-460
Options	A1-485
Model No.	A1-551
Precautions on Use	A1-557
Accessories for Lubrication	A24-1
Mounting Procedure and Maintenance	B1-89
Equivalent Moment Factor	A1-43
Rated Loads in All Directions	A1-60
Equivalent Factor in Each Direction	A1-62
Radial Clearance	A1-74
Accuracy Standards	A1-87
Shoulder Height of the Mounting Base and the Corner Radius	A1-471
Accuracy of the Mounting Surface	A1-177
Dimensions of Each Model with Options Attached	A1-499

A1-174 THK

Structure and Features

Balls are held in cages with spherical ball holders and the balls roll in four rows of circular-arc grooves in raceways on precision-ground LM rails and LM blocks.

[Smooth motion]

Because a finite stroke is used, balls do not circulate and movement is smooth even with pre-loading. Also, because variations in rolling resistance are small, this model is ideal for locations where smooth movement is required with a short stroke.

[High Rigidity]

Because model EPF uses a DB construction featuring 4 rows of circular-arc grooves, it offers particularly high rigidity with respect to moment in the M_c direction. This makes it ideal for locations where M_c moment is applied with one rail.

[Miniature Type]

Because the mounting method is compatible with the Miniature LM Guide Model RSR-N, the models are dimensionally interchangeable.

[4-way Equal Load]

Each row of balls is configured at a contact angle of 45° so that the rated loads applied to the LM block are uniform in the all directions (radial, reverse radial and lateral directions), enabling the LM Guide to be used in all orientations and in extensive applications.

[Ball cage technology application 1]

Because the cage is formed out of plastic resin, there is no metal contact between the cage and the balls, providing excellent noise characteristics, low dust emissions and long product life.

[Ball cage technology application 2]

Forming the cage in a spherical shape out of plastic resin allows lubricant to be held in grease pockets, enabling long periods of maintenance-free operation.

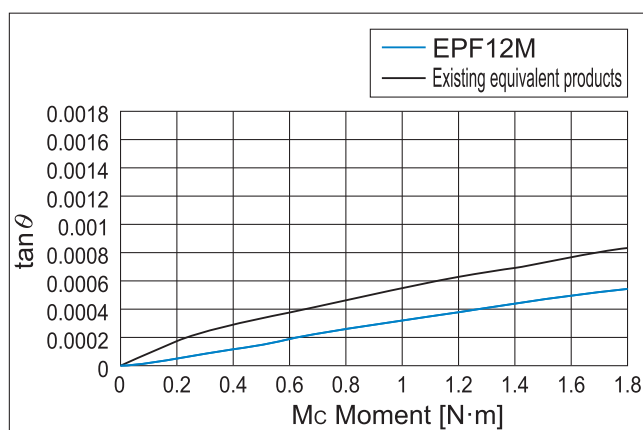
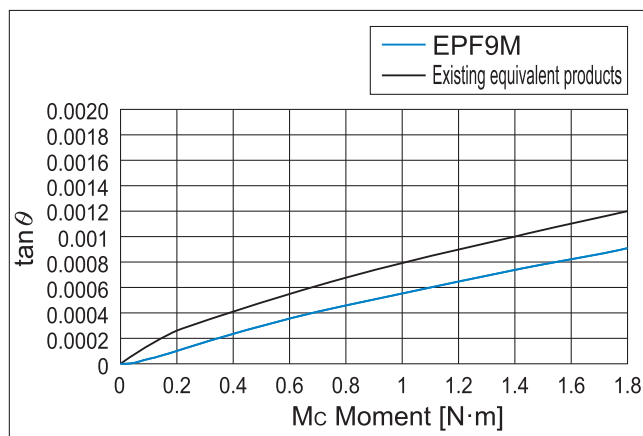

Fig.1 Comparison of M_c moment test data

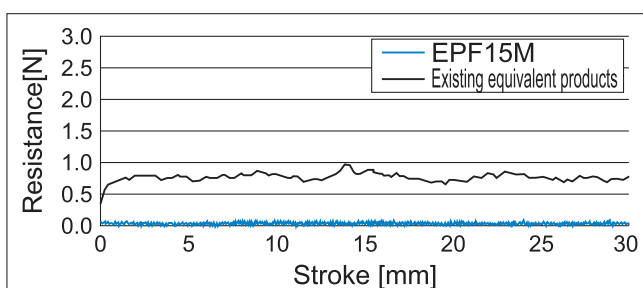
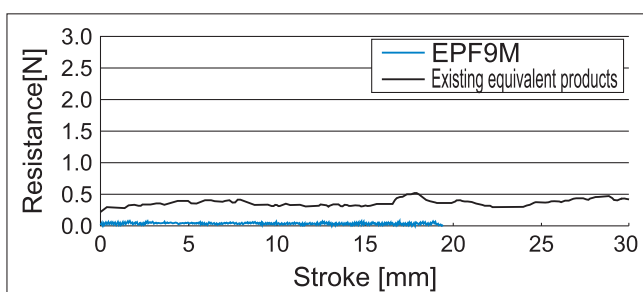
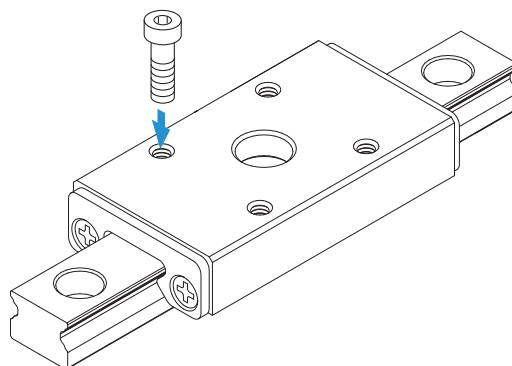

Fig.2 Comparison of rolling resistance test data

Types and Features

Model EPF

Specification Table⇒ **A1-178**



A1-176 THK

Accuracy of the Mounting Surface

If there is not sufficient precision in the LM rail and LM block mounting surfaces, the product may not function to its full potential. Table 1 Machine to values no higher than those shown in... (Recommended value: 70% of Table 1)

Table 1 Flatness of the LM Rail and the LM Block Mounting Surface
Unit: mm

Model No.	Flatness error
EPF 7M, 9M	0.015/200
EPF 12M	0.025/200
EPF 15M	0.035/200

Note) It is recommended that highly rigid materials such as iron or cast metal be used as the mounting material. If a material with poor rigidity, such as aluminum, is used, unforeseen loading may be applied to the product. In such situations, contact THK.

THK **A1-177**

Model EPF

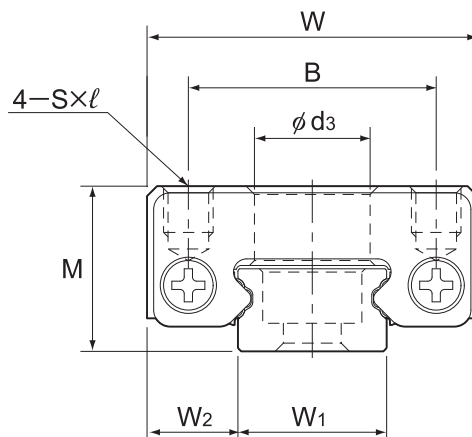

Model No.	Outer dimensions			LM block dimensions					LM rail dimensions		
	Height M	Width W	Length L _B	B	C	d ₃	S×l	L _{B1}	W ₁	W ₂	M ₁
EPF 7M	8	17	31.6	12	13	5	M2×2.3	29.6	7	5	5
EPF 9M	10	20	37.8	15	16	7	M3×2.8	35.8	9	5.5	5
EPF 12M	13	27	43.7	20	20	7	M3×3.2	41.7	12	7.5	6.75
EPF 15M	16	32	56.5	25	25	7	M3×3.5	54.5	15	8.5	9

Note) The M in the model number symbol indicates that the LM block, LM rail and balls are made of stainless steel. The stainless steel provides excellent corrosion and environmental resistance.

Model number coding

EPF7M	16	+55L	P	M
Model No.	LM rail length (in mm)	Guaranteed stroke (in mm)	Rail material: Stainless steel (standard)	Accuracy symbol (*1)

(*1) See **A1-87**.

Note) This model number indicates that a single-rail unit constitutes one set.



A1-178 **THK**

Download data by searching for the corresponding model number on the Technical Support site.

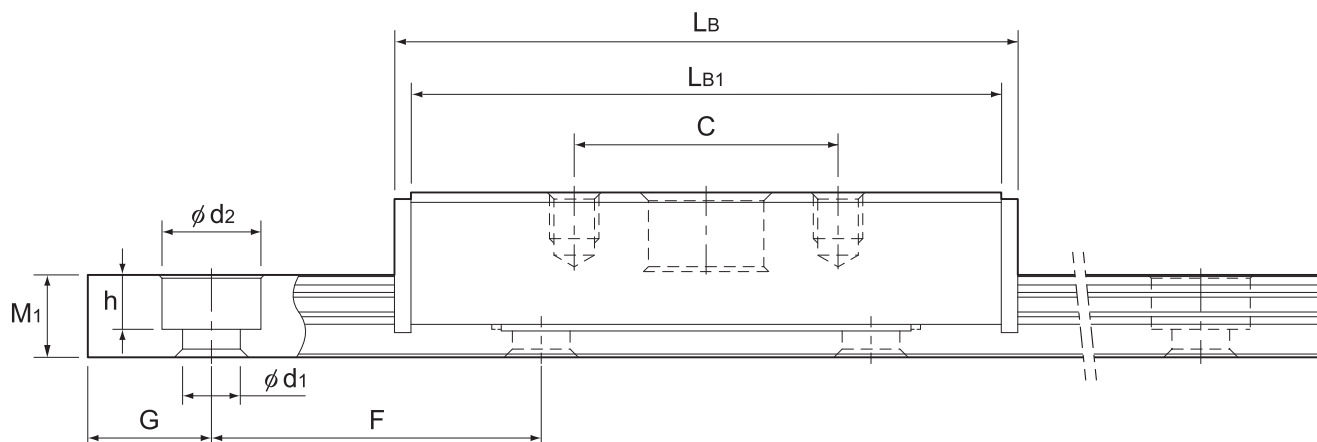
<https://tech.thk.com>



Unit: mm

			Guaranteed stroke	Basic load rating		Static permissible moment N·m*			Mass	
G	F	$d_1 \times d_2 \times h$	S_T	C	C_0	M_A	M_B	M_C	LM block	LM rail
				kN	kN				kg	kg/m
5	15	2.4×4.2×2.6	16	0.90	1.60	5.08	5.08	5.26	0.019	0.230
7.5	20	3.5×6×3.3	21	1.00	1.87	6.81	6.81	7.89	0.036	0.290
10	25	3.5×6×3.8	27	2.26	3.71	15.5	15.5	20.8	0.074	0.550
15	40	3.5×6×4	34	3.71	5.88	33.0	33.0	41.3	0.136	0.940

Note) Static permissible moment*: Static permissible moment value with 1 LM block

Recommended Tightening Torques of Mounting Bolts

Unit: N·m

Model No.	Nominal bolt	Rated tightening torque		
		Iron	Casting	Aluminum
EPF 7M	M2	0.588	0.392	0.294
EPF 9M	M3	1.96	1.27	0.98
EPF 12M				
EPF 15M				

Table2 Maximum slip resistance

Unit: N

Model No.	Maximum slip resistance
EPF 7M	20
EPF 9M	20
EPF 12M	30
EPF 15M	30

Note) While the cage used to hold the balls is designed to operate extremely precisely, factors such as impacts or inertial moment or drive vibration from the machine can cause cage distortion.

If using the EPF LM guide in the following conditions, contact THK.

- Vertical Orientation
 - Under a large moment load
 - Butting the guide's external stopper with the table
 - For applications involving high acceleration/deceleration
- If cage distortion occurs, the cage must be forcibly restored to its original shape.

Table 1 shows the required slip resistance in this event. Set the thrust so that it is no less than the maximum value shown in the table.

Options⇒ **A1-485****THK A1-179**

Standard Length of the LM Rail

Table3 shows the standard LM rail lengths of model EPF.

For special rail lengths, it is recommended to use a value corresponding to the G,g dimension from the table. As the G,g dimension increases, this portion becomes less stable, and the accuracy performance is severely impacted.

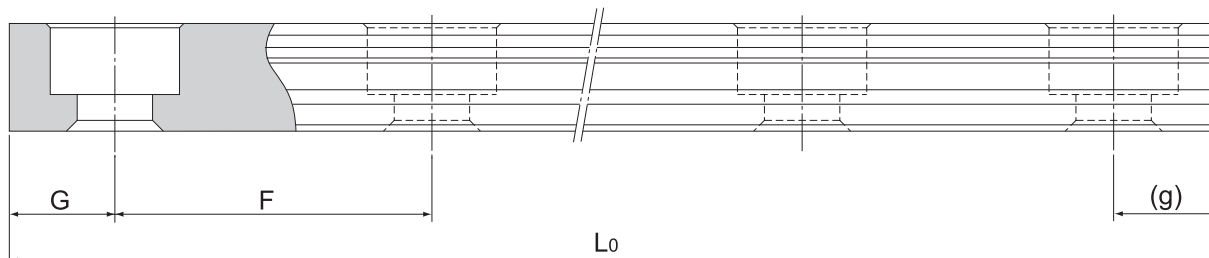

Table3 Standard Length of the LM Rail for Model EPF

Unit: mm

Model No.	EPF 7M	EPF 9M	EPF 12M	EPF 15M
LM rail standard length (L ₀)	55	75	95	110
Standard pitch F	15	20	25	40
G,g	5	7.5	10	15

Note) Lengths other than the standard LM rail length (L₀) are also available. Contact THK for details.

A1-180 THK

THK A1-181