

GSR-R

LM Guide Separate Type (Radial) Model GSR-R

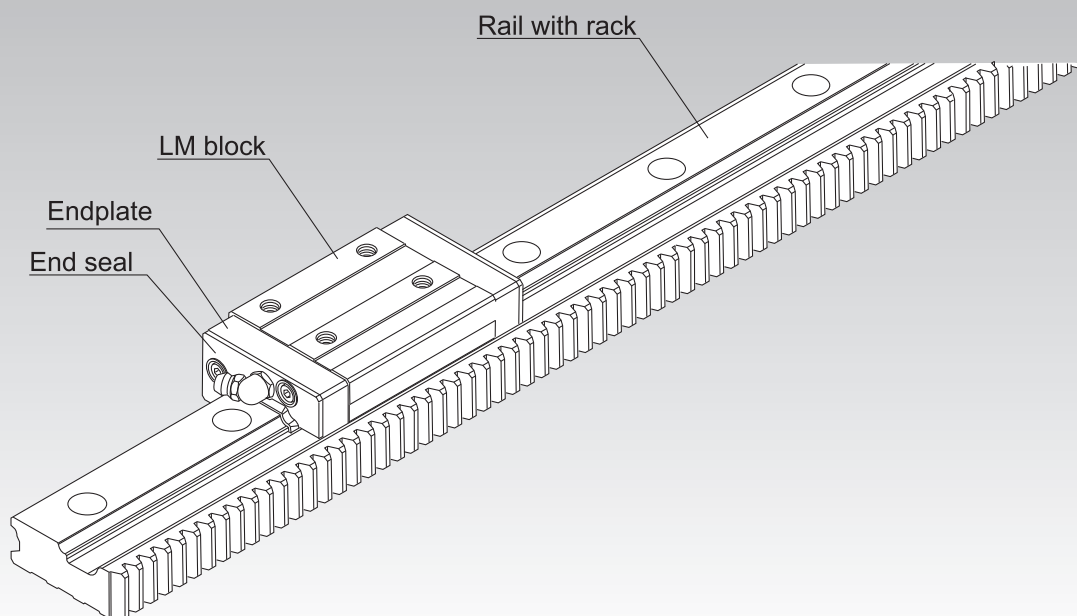

Point of Selection **A1-10**

Point of Design **A1-460**

Options **A1-485**

Model No. **A1-551**

Precautions on Use **A1-557**

Accessories for Lubrication **A24-1**

Mounting Procedure and Maintenance **B1-89**

Equivalent Moment Factor **A1-43**

Rated Loads in All Directions **A1-60**

Equivalent Factor in Each Direction **A1-62**

Accuracy Standards **A1-83**

Shoulder Height of the Mounting Base and the Corner Radius **A1-474**

Reference Error Tolerance for the Mounting Surface **A1-477**

Dimensions of Each Model with Options Attached **A1-499**

A1-298 **THK**

Structure and Features

Balls roll in two rows of raceways precision-ground on an LM rail and an LM block, and endplates incorporated in the LM block allow the balls to circulate. Since retainer plates hold the balls, they do not fall off.

As the top face of the LM block is inclined, a clearance is eliminated and an appropriate preload is applied simply by securing the LM block with mounting bolts.

Model GSR-R is based on model GSR, but has rack teeth on the LM rail. This facilitates the design and assembly of drive mechanisms.

* Model GSR-R cannot be used in single-axis applications.

[Reduced Machining and Assembly Costs]

The single-piece structure integrating the LM rail (linear guide) and rack (drive) reduces labor and time for machining the rack mounting surface and assembling and adjusting the guide system, thus to achieve significant cost reduction.

[Easy Designing]

The travel distance per turn of the pinion is specified by the integer value. This makes it easy to calculate the travel distance per pulse when the LM Guide is used in combination with a stepping motor or servomotor.

[Space Saving]

Since the rail has a rack, the machine size can be reduced.

[Long Stroke]

The end faces of the LM rail are machined for jointed use. To obtain a long stroke, simply joint LM rails of the standard length.

[High Durability]

The rack tooth has a width equal to the LM rail height, the rack uses high-grade steel with proven performance and the tooth surface are heat-treated, thereby to ensure high durability.

THK **A1-299**

Types and Features

Model GSR-R (Rail with Rack)

Specification Table⇒ **A1-309**

Since the thrust load on the pinion shaft can be kept low due to rack-pinion meshing, it is easy to design systems with pinion shaft bearings and tables that are not so rigid.

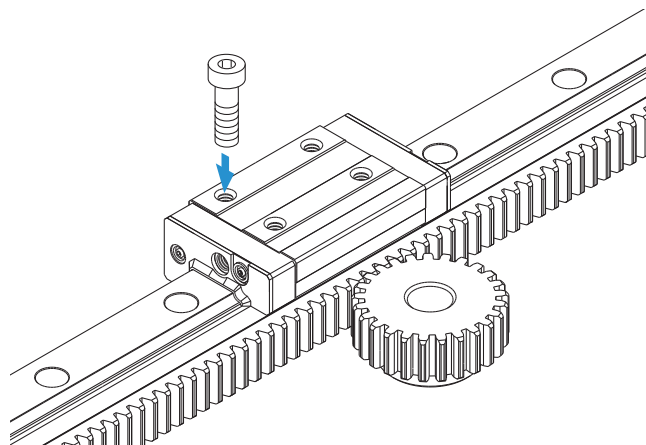

A1-300 **THK**

THK A1-301

Model GSR-R

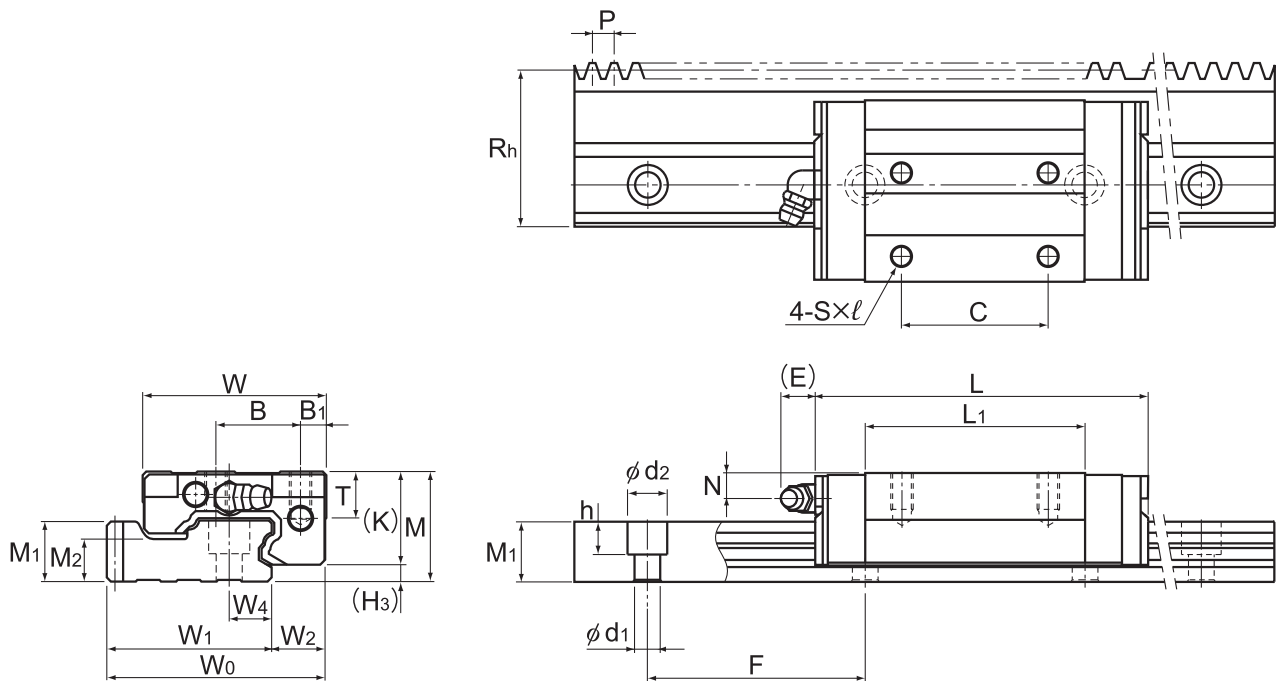

Model GSR-T-R

Model No.	Rack			Outer dimensions				LM block dimensions										Grease nipple	H ₃
	Reference pitch dimension	Module	Pitch line height	Height	Width	Length													
	P		Rh	M	W	W ₀	L	B ₁	B	C	S×ℓ	L ₁	T	K	N	E			
GSR 25V-R GSR 25T-R	6	1.91	43	30	50	59.91	69 88	7	23	— 40	M6×10	41.2 60.2	12.7	25.4	7	12	B-M6F	4.6	
GSR 30T-R	8	2.55	48	33	57	67.05	103	8	26	45	M8×12	70.3	14.6	28.5	7	12	B-M6F	4.5	
GSR 35T-R	10	3.18	57	38	68	80.18	117	9	32	50	M8×15	80.3	15.6	32.5	8	12	B-M6F	5.5	

Note) A special type with a module pitch is also available. Contact THK for details.
For checking the pinion strength, see **A1-306**.

Model number coding

Single-rail LM Guide

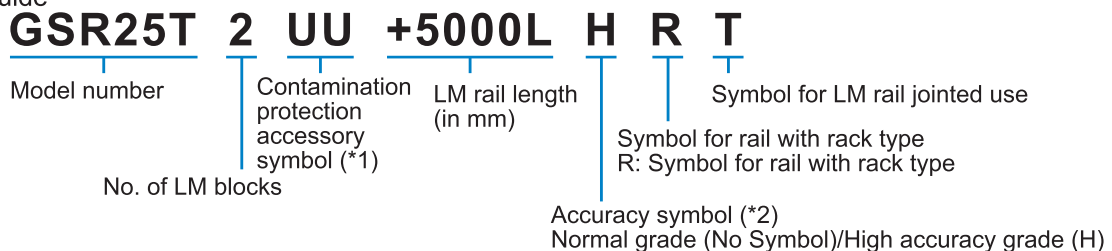

(*1) See contamination protection accessory on **A1-524**. (*2) See **A1-83**.

Note) This model number indicates that a single-rail unit constitutes one set.

A1-302 **THK**

Download data by searching for the corresponding model number on the Technical Support site.

<https://tech.thk.com>

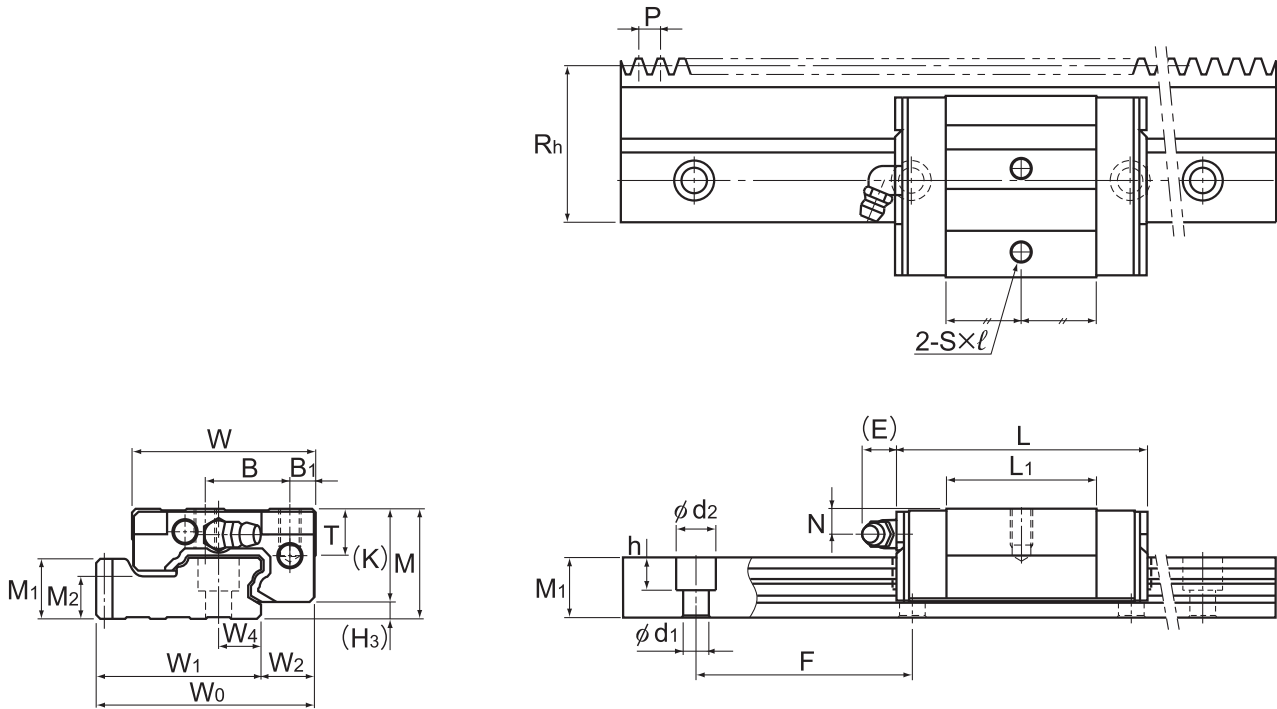

Model GSR25V-R

Unit: mm

LM rail dimensions							Basic load rating		Static permissible moment kN·m*				Mass	
Width			Height	Pitch			C	C ₀	M _A		M _B		LM block	LM rail
W ₁	W ₂	W ₄	M ₁	F	M ₂	d ₁ × d ₂ × h	kN	kN	1 block	Double blocks	1 block	Double blocks	kg	kg/m
44.91	15	11.5	16.5	60	11.5	7 × 11 × 9	15.5 20	15.2 22	0.102 0.205	0.625 1.11	0.0891 0.176	0.541 0.961	0.29 0.5	4.7
50.55	16.5	14	19	80	12	9 × 14 × 12	27.8	29.9	0.325	1.77	0.28	1.52	0.6	5.9
60.18	20	17	22	80	14.5	11 × 17.5 × 14	37	39.1	0.485	2.63	0.419	2.27	1	8.1

Note1) The maximum length under "Length*" indicates the standard maximum length of an LM rail. (See **A1-304**.)

Static permissible moment* 1 block: the static permissible moment with one LM block

Double blocks: static permissible moment when two LM blocks are in close contact with each other. A moment in the M_C direction can be received if two rails are used in parallel. However, since it depends on the distance between the two rails, it has been omitted.

Total block length L : The total block length L shown in the table is the length with the dust proof parts, code UU or SS. If other contamination protection accessories or lubricant equipment are installed, the total block length will increase.

(See **A1-499** or **A1-520**)

For oil lubrication, be certain to contact THK with the mounting orientation.

(Mounting orientation: see **A1-12**, Lubricant: see **A24-2**)

Note2) The basic load rating in the dimension table is for a load in the radial direction. Use Table7 on **A1-60** to calculate the load rating for loads in the reverse radial direction or lateral direction.

Model number coding

LM block

GSR25T UU

Model number

Contamination protection accessory symbol (*1)

Rail with rack

GSR25-2004L H R

Accuracy symbol (*2)
Normal grade (No Symbol)
High accuracy grade (H)

R: Symbol for rail with rack type

(*1) See contamination protection accessory on **A1-524**. (*2) See **A1-83**.

Options ⇒ **A1-485**

THK A1-303

Standard Length of the LM Rail

Table1 shows the standard LM rail lengths of model GSR-R variations.

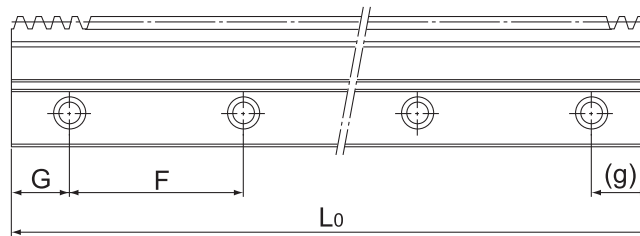

Table1 Standard Length of the LM Rail for Model GSR-R

Unit: mm

Model No.	GSR 25-R		GSR 30-R		GSR 35-R	
LM rail Standard length (L_0)	1500	2004	1504	2000	1500	2000
Standard pitch F	60	60	80	80	80	80
G, g	30	42	32	40	30	40

A1-304 THK

Rack and Pinion

[Joining Two or More Rails]

The end faces of the rail with rack are machined so that a clearance is left after assembly in order to facilitate the assembly.

Use of a special jig as shown in Fig.1 will make the connection easier.

(THK also offers the rack-aligning jig.)

[Reworking the Pinion Hole]

Only the teeth of the reworkable pinion-hole-diameter type (type C) are heat-treated. The hole and keyway can therefore be reworked by the user to the desired diameter and shape.

When reworking the pinion hole, be sure to take the following into account.

The material of the reworkable hole diameter type (type C): S45C

- (1) When chucking the teeth of a reworkable hole diameter type, use a jaw scroll chuck or something like it to maintain the tooth profile.
- (2) The pinion is produced using the center of the hole as a reference point. The center of the hole should therefore be used as a reference point when the pinion is aligned. When checking the pinion runout, refer to the boss sides.
- (3) Keep the reworked hole diameter within roughly 60 to 70% of the boss diameter.

[Lubricating the Rack and Pinion]

To ensure smooth sliding on tooth surfaces and prevent wear, the teeth should be provided with a lubricant.

Note1) Use a lubricant of the same type of thickener as that contained in the LM Guide.

Note2) Unpredictable wear may occur in the rack and pinion according to load conditions and lubrication status. Contact THK when undertaking design.

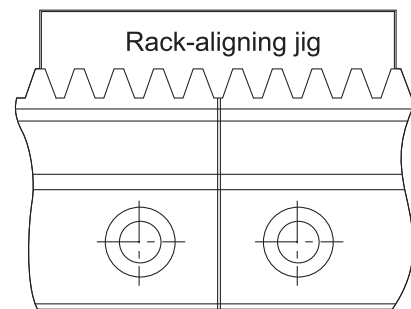

Fig.1 Rack Connection Method

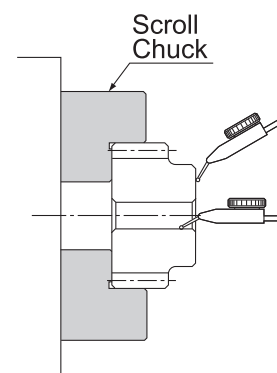

Fig.2

[Checking Strength]

The strength of the assembled rack and pinion must be checked in advance.

- (1) Calculate the maximum thrust acting on the pinion.
- (2) Divide the permissible power transmission capacity of the pinion to be used (Table1) by an overload factor (Table2).
- (3) By comparing the thrust acting on the pinion obtained in step 1 with the pinion power transmission capacity obtained in step 2, make sure the applied thrust does not exceed the permissible power transmission capacity.

[Example of calculation]

Model GSR-R is used in a horizontal conveyance system receiving a medium impact (assuming external load to be zero).

● Conditions

Subject model No. (pinion) GP6-20A
 Mass (table + work) m=100kg
 Speed v=1 m/s
 Acceleration/deceleration time $T_1 = 0.1$ s

● Consideration

- (1) Calculating the maximum thrust
 Calculated the thrust during acceleration/deceleration.

$$F_{\max} = m \cdot \frac{v}{T_1} = 1.00 \text{ kN}$$

- (2) Permissible power transmission capacity of the pinion

$$P_{\max} = \frac{\text{Permissible power transmission capacity (see Table 1)}}{\text{Overload factor (see Table 2)}} = \frac{2.33}{1.25} = 1.86 \text{ kN}$$

- (3) Comparison between the maximum thrust and the permissible power transmission capacity of the pinion

$F_{\max} < P_{\max}$

Therefore, it is judged that the subject model number can be used.

Table1 Permissible Power transmission Capacity

Unit: kN

Model No.	Permissible Power transmission Capacity	Supported model
GP 6-20A	2.33	GSR 25-R
GP 6-20C	2.05	
GP 6-25A	2.73	
GP 6-25C	2.23	
GP 8-20A	3.58	GSR 30-R
GP 8-20C	3.15	
GP 8-25A	4.19	
GP 8-25C	3.42	
GP10-20A	5.19	GSR 35-R
GP10-20C	4.57	
GP10-25A	6.06	
GP10-25C	4.96	

Table2 Overload Factor

Impact from the prime mover	Impact from the driven machine		
	Uniform load	Medium impact	Large impact
Uniform load (electric motor, turbine, hydraulic motor, etc.)	1.0	1.25	1.75

(Excerpt from JGMA401-01)

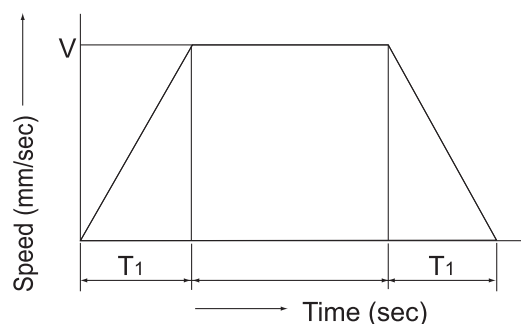
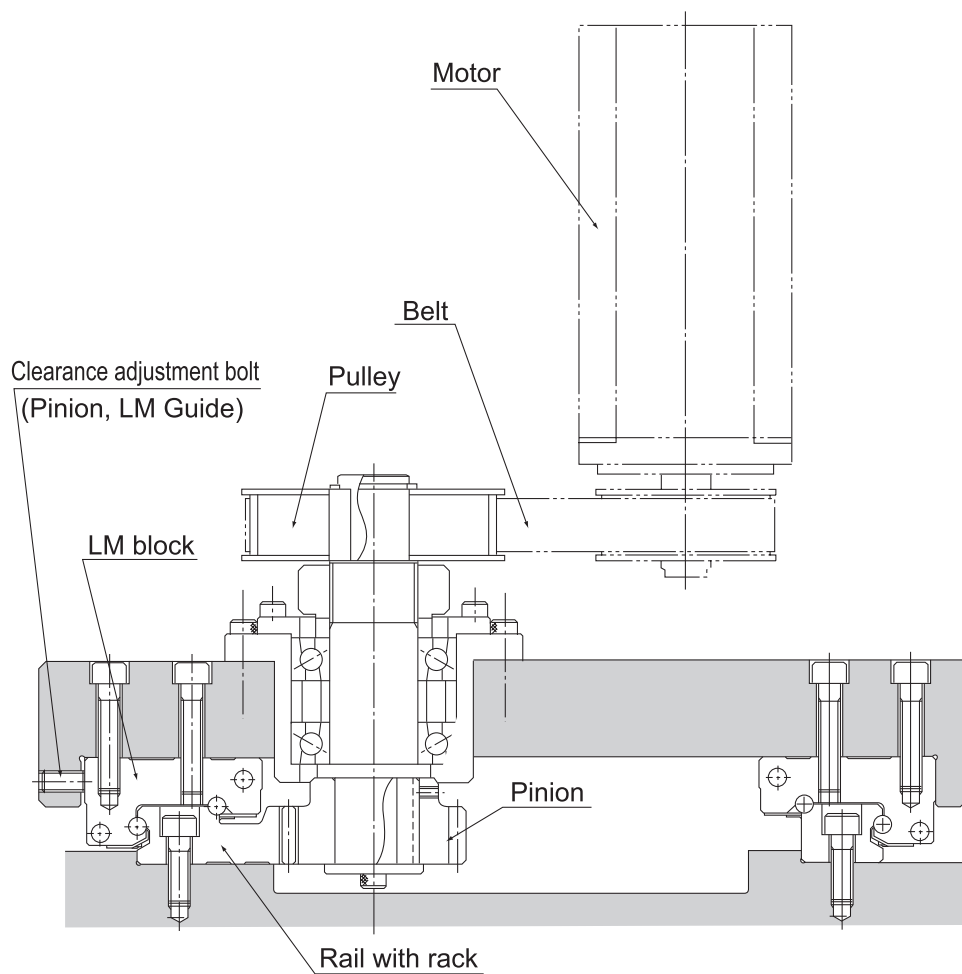
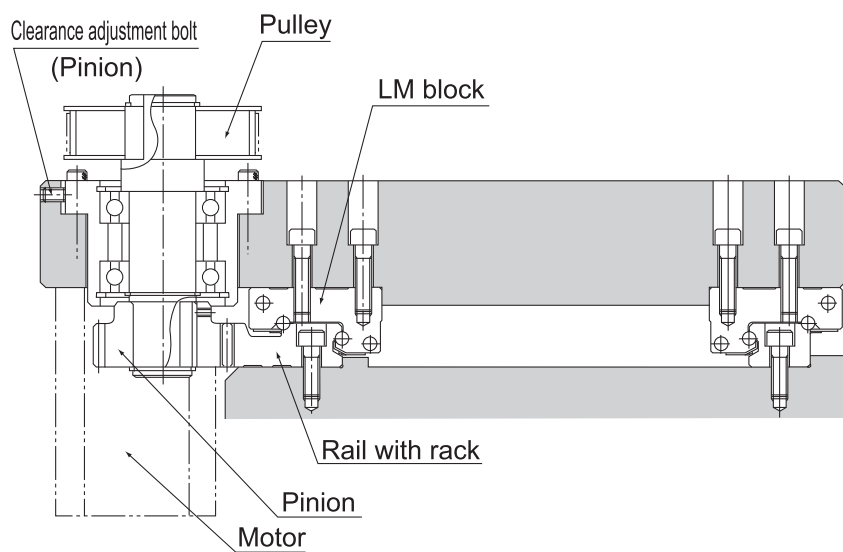

Fig.3

A1-306 THK

[Example of Assembling Model GSR-R with the Table]



Rack and Pinion Dimensional Drawing

[Pinion for rack - type A]

The keyway worked type

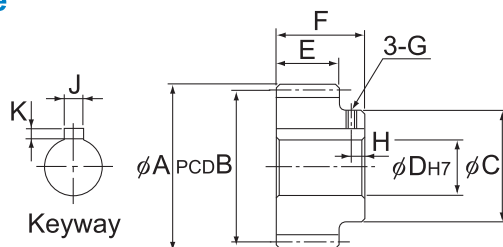

Unit: mm

Model No.	Pitch	Number of teeth	Tip circle diameter A	Meshing PCD B	Boss diameter C	Hole diameter D	Tooth width E	Overall length F	G	H	Keyway J×K	Supported model numbers
GP6-20A	6	20	42.9	39	30	18	16.5	24.5	M3	4	6×2.8	GSR 25-R
GP6-25A		25	51.9	48	35	18						
GP8-20A	8	20	57.1	52	40	20	19	26	M3	5	8×3.3	GSR 30-R
GP8-25A		25	69.1	64	40	20						
GP10-20A	10	20	70.4	64	45	25	22	30	M4	5	8×3.3	GSR 35-R
GP10-25A		25	86.4	80	60	25					10×3.3	

Note1) When placing an order, specify the model number from the table.

Note2) Non-standard pinions with different numbers of teeth are also available upon request. Contact THK for details.

A1-308 THK

[Pinion for rack - type C]

The reworkable hole diameter type

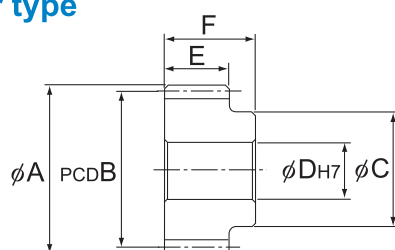

Unit: mm

Model No.	Pitch	Number of teeth	Tip circle diameter A	Meshing PCD B	Boss diameter C	Hole diameter D	Tooth width E	Overall length F	Supported model numbers
GP 6-20C	6	20	42.9	39	30	12	16.5	24.5	GSR 25-R
GP 6-25C		25	51.9	48	35	15			
GP 8-20C	8	20	57.1	52	40	18	19	26	GSR 30-R
GP 8-25C		25	69.1	64	40	18			
GP10-20C	10	20	70.4	64	45	18	22	30	GSR 35-R
GP10-25C		25	86.4	80	60	18			

Note1) When placing an order, specify the model number from the table.

Note2) Non-standard pinions with different numbers of teeth are also available upon request. Contact THK for details.

[The dimension when the LM rail is used in combination with a pinion]

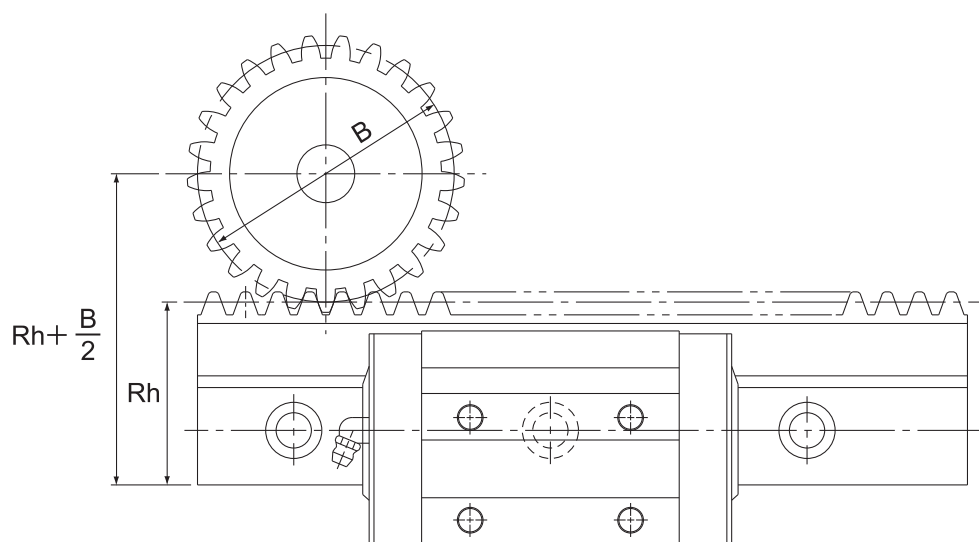

Unit: mm

Model GSR Model No.	Pinion Model No.	LM rail Pitch line height Rh	Pinion Meshing PCD B	Rh+B/2
GSR 25-R	GP 6-20A	43	39	62.5
	GP 6-20C		48	67
	GP 6-25A			
	GP 6-25C			
GSR 30-R	GP 8-20A	48	52	74
	GP 8-20C		64	80
	GP 8-25A			
	GP 8-25C			
GSR 35-R	GP 10-20A	57	64	89
	GP 10-20C		80	97
	GP 10-25A			
	GP 10-25C			

THK A1-309