

HSR-M1VV

LM Guide Medium-to-low Vacuum Type Model HSR-M1VV

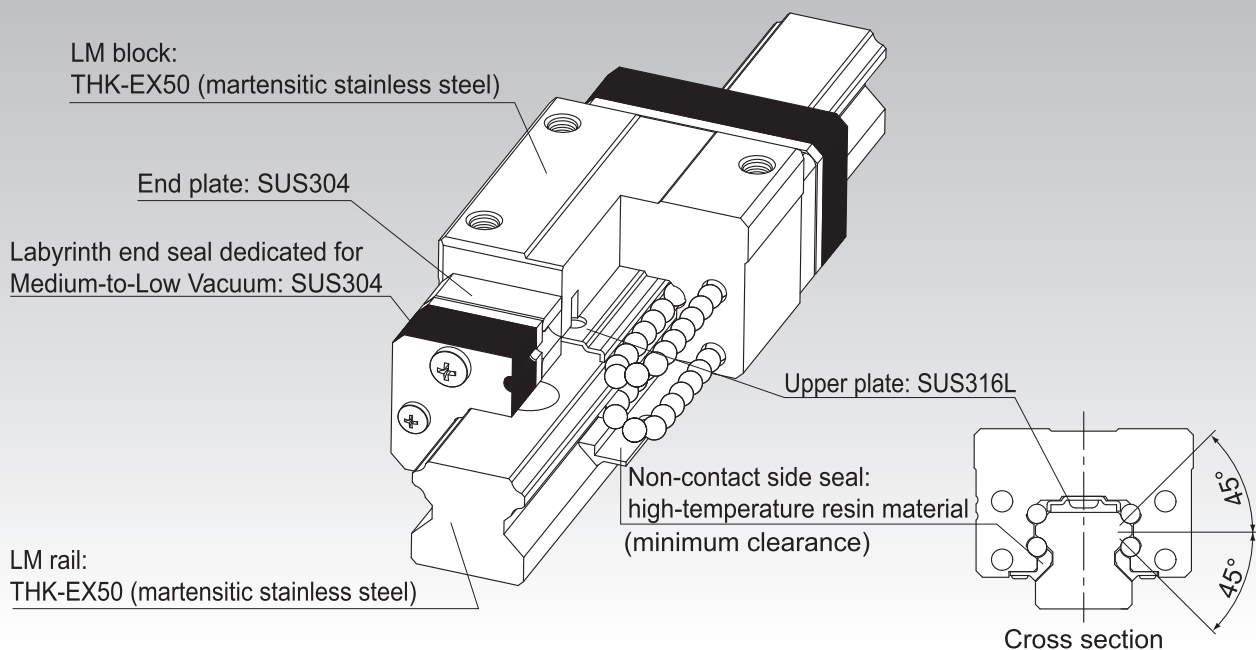

Point of Selection **A1-10**

Point of Design **A1-460**

Options **A1-485**

Model No. **A1-551**

Precautions on Use **A1-559**

Accessories for Lubrication **A24-1**

Mounting Procedure and Maintenance **B1-89**

Equivalent Moment Factor **A1-43**

Rated Loads in All Directions **A1-60**

Equivalent Factor in Each Direction **A1-62**

Radial Clearance **A1-73**

Accuracy Standards **A1-78**

Shoulder Height of the Mounting Base and the Corner Radius **A1-471**

Reference Error Tolerance for the Mounting Surface **A1-476**

Flatness of the Mounting Surface **A1-478**

Dimensions of Each Model with Options Attached **A1-499**

A1-406 **THK**

Structure and Features

[Features]

- Operable in various environments at pressure between atmospheric pressure and vacuum (10^{-3} [Pa]).
- Capable of withstanding baking temperature up to 200°C *
- Use of a newly developed labyrinth end seal dedicated for Medium-to-Low Vacuum increases grease retention and allows extended use in vacuum.
- Use of grease designed for Medium-to-Low Vacuum achieves a stable rolling resistance.

* If the baking temperature exceeds 100°C , multiply the basic load rating with the temperature coefficient.

Structure of the labyrinth end seal dedicated for Medium-to-Low Vacuum

The labyrinth end seal dedicated for Medium-to-Low Vacuum forms a multi-stage space as shown in the figure on the right to minimize the pressure difference between adjacent stages. This reduces the out-flow velocity of the oil inside the LM block to a minimum. In addition, the seal will not affect the rolling resistance since it does not contact the LM rail.

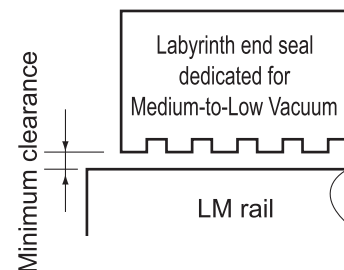

[Achievable vacuum level]

The LM Guide for Medium-to-Low Vacuum demonstrates an excellent achievable vacuum level.

[Test conditions] Temperature: 25°C ($\pm 5^{\circ}\text{C}$)

	HSR15M1RVV	HSR15R (for reference)
Grease	Grease for Medium-to-Low Vacuum	AFB-LF Grease
Seal	Labyrinth end seal dedicated for Medium-to-Low Vacuum	None
Endplate	Stainless steel	Resin

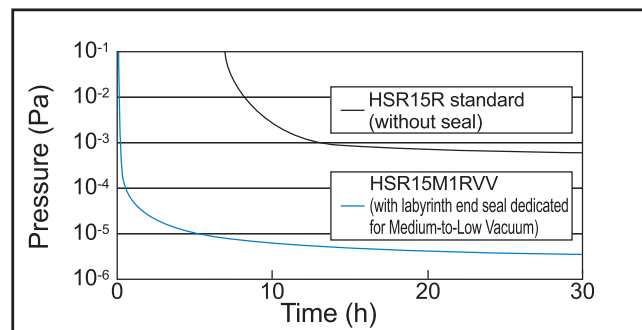

Achievable vacuum level

[Rolling resistance]

The grease used in the LM Guide for Medium-to-Low Vacuum has a smaller rolling resistance than conventional fluorine grease and ensures stable rolling motion.

Specimen: HSR15M1RVV

Temperature: 25°C ($\pm 5^{\circ}\text{C}$)

Pressure: atmospheric pressure

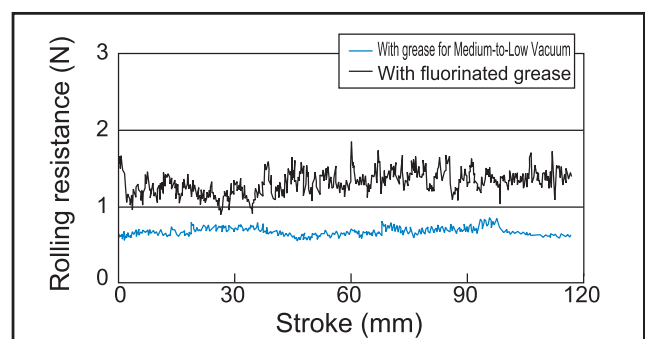

Rolling resistance fluctuation

THK **A1-407**

Types and Features

Model HSR-M1RVV

Specification Table⇒ **A1-410**

With this type, the LM block has a smaller width (W) and tapped holes. Used in places where the space for table width is limited.

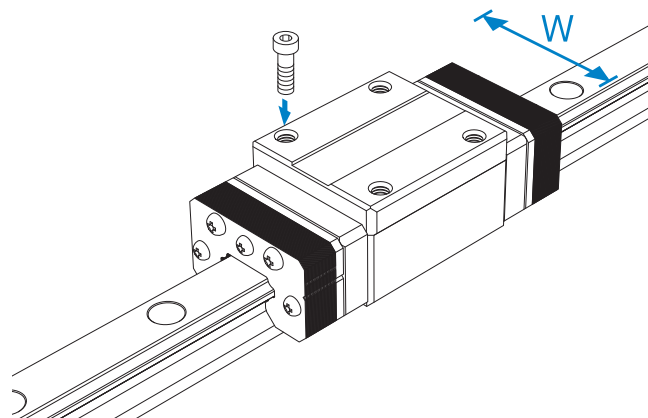

Precautions on Design

If a large moment is applied to a system consisting of one LM rail or one LM block per shaft, the labyrinth end seal may contact the LM rail, which could affect the system's motion.

If a moment is applied, it is recommended to use two rails with two LM blocks per rail. Contact THK for details.

A1-408 THK

THK A1-409

Model HSR-M1VV

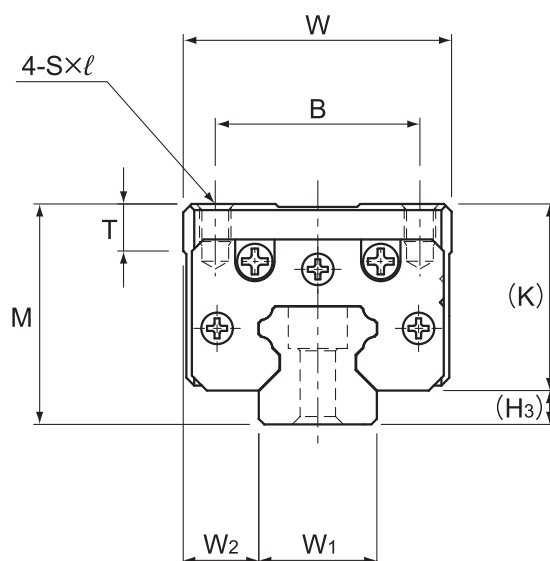

Model No.	Outer dimensions			LM block dimensions						
	Height	Width	Length	B	C	S×ℓ	L ₁	T	K	H ₃
	M	W	L							
HSR15M1R-VV	28	34	75	26	26	M4×5	38.8	6	23.7	4.3

Model number coding

HSR15M1R 1 VV C1 +400L P -II

Model No.

Radial clearance
symbol (*1)

Labyrinth seal
symbol (*2)

No. of LM blocks
used on the same rail

Accuracy
symbol (*3)

LM rail length
(in mm)

Symbol for
No. of rails used on the
same plane (*4)

(*1) See **A1-73**. (*2) See **A1-407**. (*3) See **A1-78**. (*4) See **A1-13**.

Note1) The radial clearance, maximum LM rail length and accuracy class are equal to that of model HSR.

Note2) With this model, a single-rail unit constitutes one set (i.e., the required number of sets when 2 rails are used in parallel is 2).

A1-410 THK

Download data by searching for the corresponding
model number on the Technical Support site.

<https://tech.thk.com>

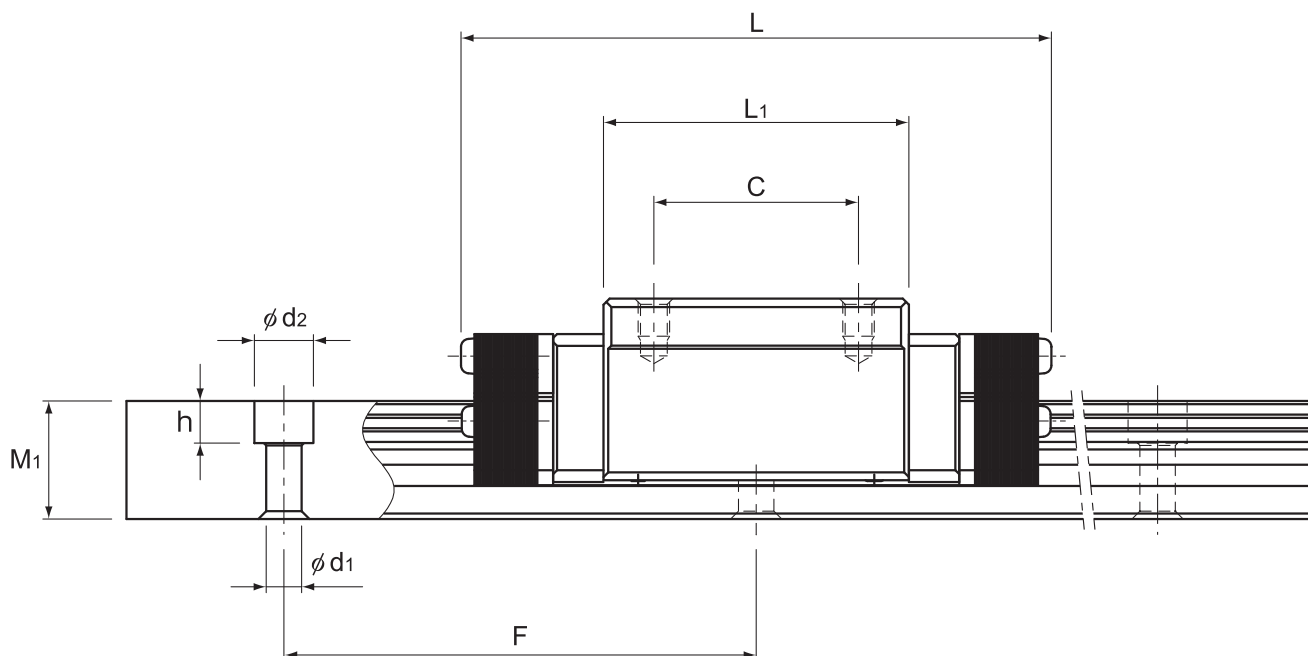

Unit: mm

LM rail dimensions						Basic load rating		Static permissible moment kN·m*					Mass	
Width	Height		Pitch	Length*		C	C ₀	M _A		M _B		M _C	LM block	LM rail
W ₁ ±0.05	W ₂	M ₁	F	d ₁ × d ₂ × h	Max	kN	kN	1 block	Double blocks	1 block	Double blocks	1 block	kg	kg/m
15	9.5	15	60	4.5 × 7.5 × 5.3	1240	10.9	15.7	0.0945	0.527	0.0945	0.527	0.0998	0.27	1.5

Note) The maximum length under "Length*" indicates the standard maximum length of an LM rail. (See **A1-412**.)

Static permissible moment* 1 block: the static permissible moment with one LM block

Double blocks: static permissible moment when two LM blocks are in close contact with each other

Total block length L : The total block length L shown in the table is the length with the dust-proof parts (code: VV, with labyrinth end seal).

If a large moment is applied to a system consisting of one LM rail or one LM block per shaft, the labyrinth end seal may contact the LM rail, which could affect the system's motion.

If a moment is applied, it is recommended to use two rails with two LM blocks per rail.

Contact THK for details.

Options ⇒ **A1-485**

THK A1-411

Standard Length and Maximum Length of the LM Rail

Table1 shows the standard and maximum lengths for Model HSR-M1VV rails. If the maximum length of the desired LM rail exceeds these values, contact THK.

For special rail lengths, it is recommended to use a value corresponding to the G,g dimension from the table. As the G,g dimension increases, this portion becomes less stable, and the accuracy performance is severely impacted.

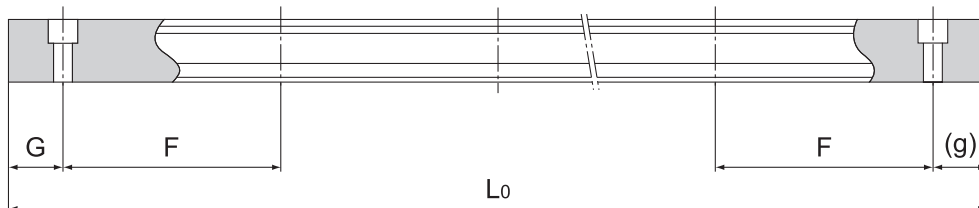

Table1 Standard Length and Maximum Length of the LM Rail for Model HSR-M1VV

Unit: mm

Model No.	HSR15M1R-VV
LM rail standard length (L_0)	160
	220
	280
	340
	400
	460
	520
	580
	640
	700
	760
	820
	940
	1000
1060	
1120	
1180	
1240	
Standard pitch F	60
G,g	20
Max length	1240

Note1) The maximum length varies with accuracy grades. Contact THK for details.

Note2) If a length greater than the above maximum is required, contact THK.

A1-412 THK

THK A1-413

Structure and Features of the Caged Roller LM Guide

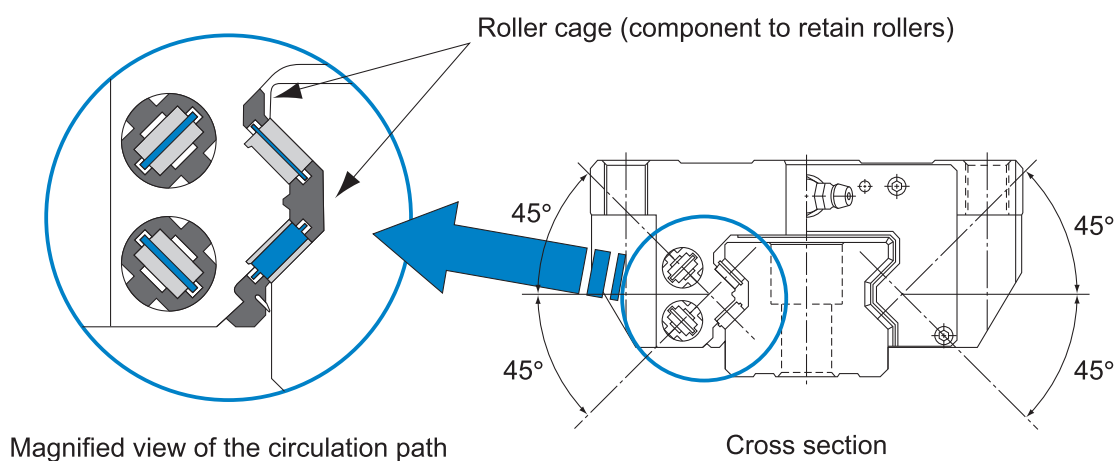
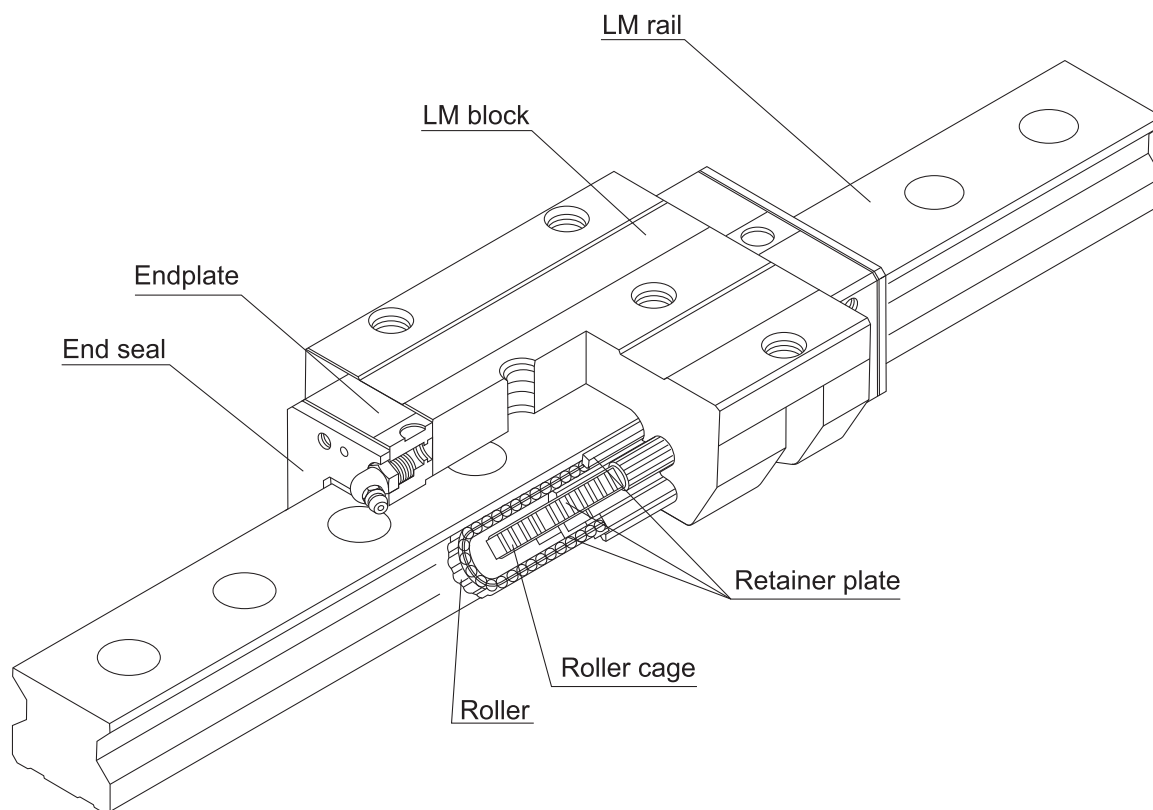

Fig.1 Structural Drawing of the Caged Roller LM Guide Model SRG

Caged Roller LM Guide is a roller guide that achieves low-friction, smooth motion and long-term maintenance-free operation by using a roller cage. In addition, to ensure ultra-high rigidity, rollers with low elastic deformation are used as the rolling elements and the roller diameter and the roller length are optimized.

Furthermore, the lines of rollers are placed at a contact angle of 45° so that the same rated load is applied in all (radial, reverse and lateral) directions.

A1-414 THK

Advantages of the Caged Roller Technology

- (1) Evenly arranged rollers circulate in a way that limits the front-to-back and side-to-side movements of the rollers, preventing the rollers from skewing and minimizing rolling resistance fluctuations. The end result is smooth and stable motion.
- (2) The absence of friction between rollers and the retention of lubrication in grease pockets enable long-term maintenance-free operation.
- (3) The absence of friction between rollers achieves low heat generation and superbly high speed.
- (4) The absence of roller-to-roller collision ensures low noise and acceptable running sound.

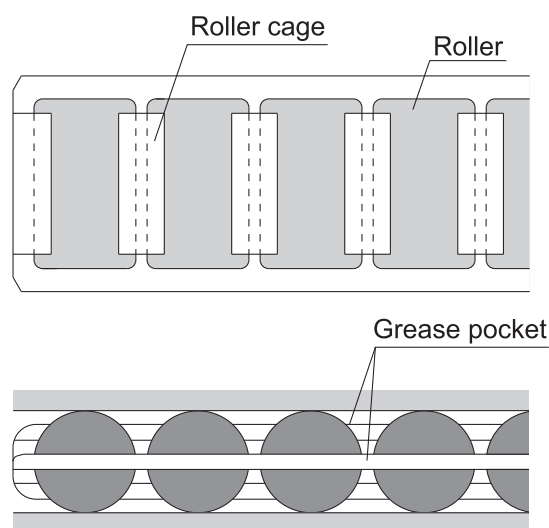

[Smooth Motion]

● Rolling Resistance Data

Evenly spaced and aligned rollers circulate, minimizing rolling resistance fluctuations and achieving smooth and stable motion.

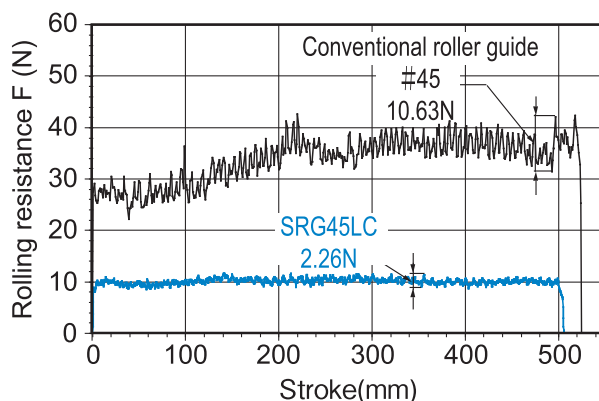

Result of Measuring Rolling Resistance Fluctuations

[Conditions]

Feeding speed: 10mm/s

Applied load: no load (one block)

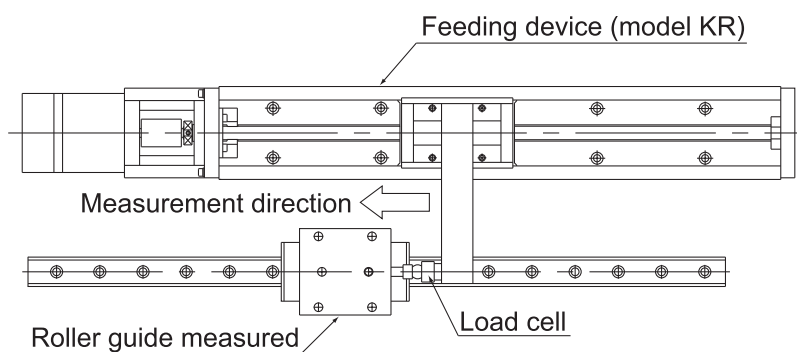

Rolling Resistance Measuring Machine

THK **A1-415**

[Long-term Maintenance-free Operation]

● High-speed Durability Test Data

Use of a roller cage eliminates friction between rollers, minimizes heat generation and increases grease retention, thus to achieve long-term maintenance-free operation.

[Conditions]

Model No.: SRG45LC

Magnitude of preload: clearance C0

Speed: 180m/min

Acceleration: 1.5G

Stroke: 2300mm

Lubrication : Initial lubrication only
(THKAFB-LF Grease)

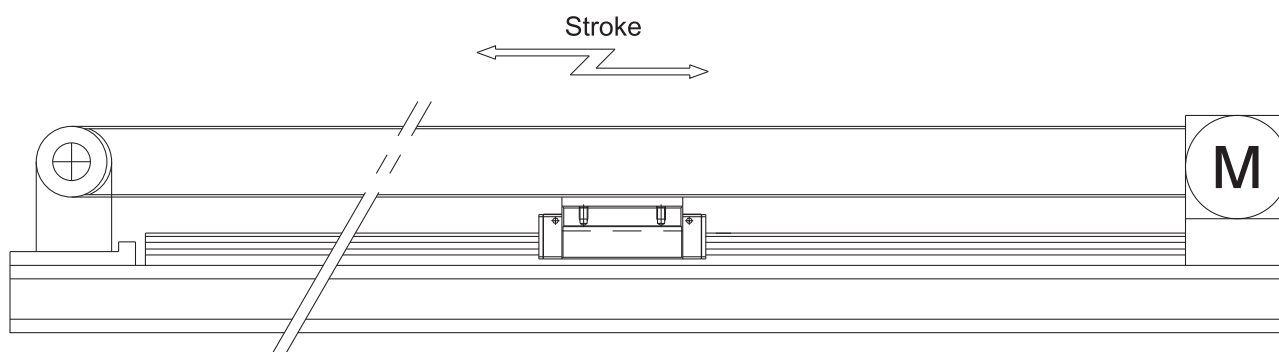
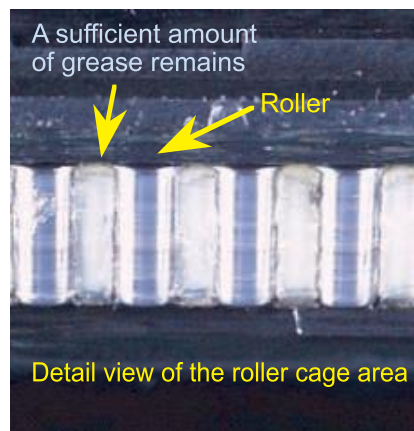

Test result: No anomaly observed after running 15,000 km

Result of High-speed Durability Test

A1-416 THK

Features and Dimensions of Each Model

Structure and Features of the Caged Roller LM Guide

[Ultra-high Rigidity]

● High Rigidity Evaluation Data

[Preload] SRG : radial clearance C0

Conventional type : radial clearance equivalent to C0

Radial rigidity

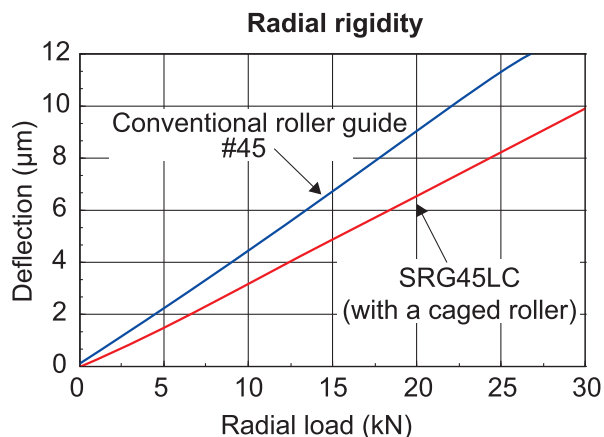
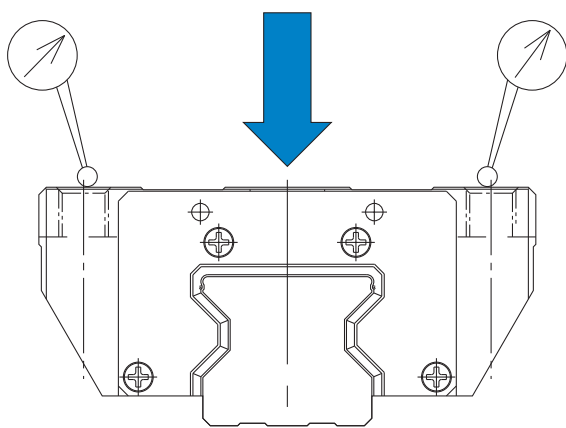

Reverse radial rigidity

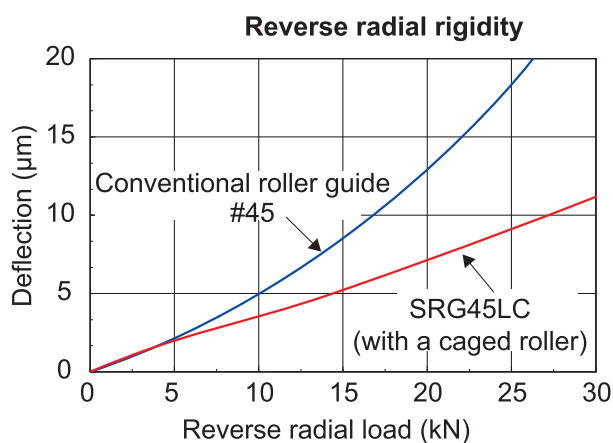
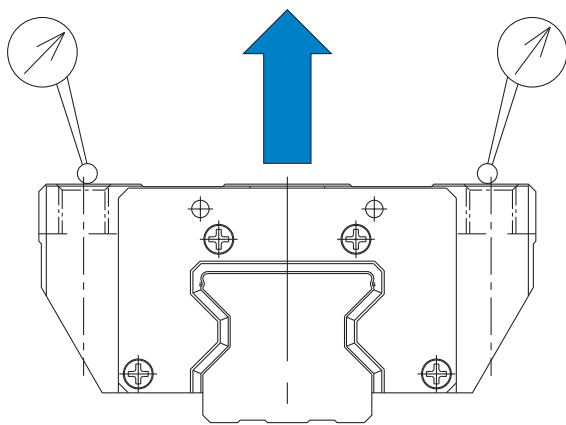

Horizontal rigidity

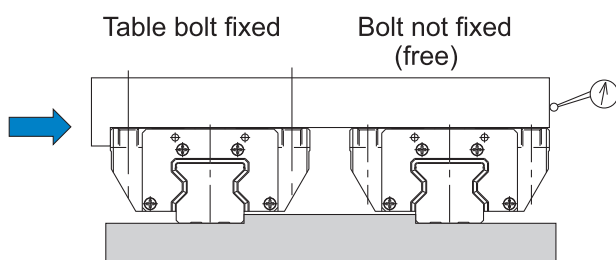

Rigidity is measured with the two axes placed in parallel and one of the axes not fixed with a bolt in order not to apply a moment.

