

# JR

## LM Guide Structural Member Rail Model JR

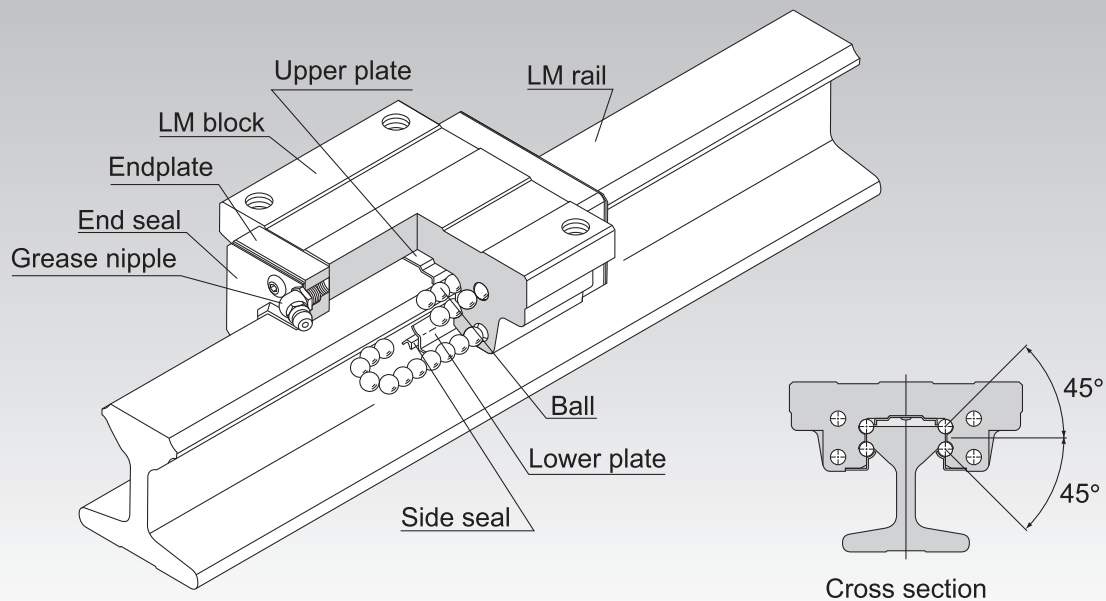

<b>Point of Selection</b>	<b>A1-10</b>
<b>Point of Design</b>	<b>A1-460</b>
<b>Options</b>	<b>A1-485</b>
<b>Model No.</b>	<b>A1-551</b>
<b>Precautions on Use</b>	<b>A1-557</b>
<b>Accessories for Lubrication</b>	<b>A24-1</b>
<b>Mounting Procedure and Maintenance</b>	<b>B1-89</b>
Equivalent Moment Factor	<b>A1-43</b>
Rated Loads in All Directions	<b>A1-60</b>
Equivalent Factor in Each Direction	<b>A1-62</b>
Radial Clearance	<b>A1-74</b>
Accuracy Standards	<b>A1-80</b>
Shoulder Height of the Mounting Base and the Corner Radius	<b>A1-469</b>
Reference Error Tolerance for the Mounting Surface	<b>A1-476</b>
Dimensions of Each Model with Options Attached	<b>A1-499</b>

**A1-324 THK**

## Structure and Features

Balls roll in four rows of raceways precision-ground on an LM rail and an LM block, and endplates incorporated in the LM block allow the balls to circulate. Since retainer plates hold the balls, they do not fall off even if the LM rail is pulled out.

Model JR uses the same LM block as model HSR, which has a proven track record and is highly reliable. The LM rail has a sectional shape with high flexural rigidity, and therefore can be used as a structural member.

Unlike the conventional LM Guide type, whose LM rail was secured onto the base with bolts when installed, model JR's LM rail is integrated with the mounting base, and the top of the LM rail has the same structure as LM Guide model HSR. The lower part of the LM rail has a hardness of 25HRC or less, making it easy to cut the rail and enabling the rail to be welded.

When welding the rail, we recommend using welding rods compliant with JIS D 5816. (suggested manufacturer and model number: Kobelco LB-52).

### [4-way Equal Load]

Each row of balls is placed at a contact angle of 45° so that the rated loads applied to the LM block are uniform in the four directions (radial, reverse radial and lateral directions), enabling the LM Guide to be used in all orientations.

### [Can be Mounted Even Under Rough Conditions]

Since the center of the cross-section of the LM rail is slightly thinner, even if the parallelism between two rails is not accurate the LM rail is capable of absorbing the error by bending inward or outward.

### [Sectional Shape with High Flexural Rigidity]

Since the LM rail has a sectional shape with high flexural rigidity, it can also be used as a structural member. In addition, even when the LM rail is partially fastened or supported in cantilever, the distortion is minimal.

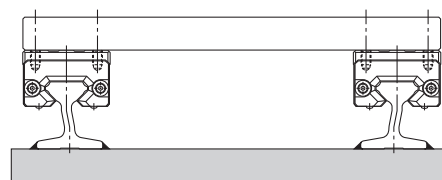

Fig.1

## Second Moment of Inertia of the LM Rail

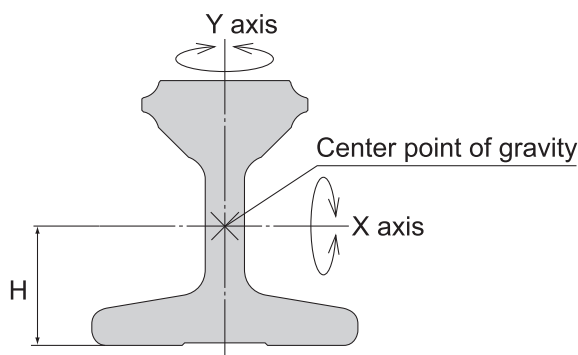

Fig.2

	Geometrical moment of inertia $I$ [ $\times 10^5$ mm <sup>4</sup> ]		Modulus of section $Z$ [ $\times 10^4$ mm <sup>3</sup> ]		Height of gravitational center $H$ [mm]
	About X axis	About Y axis	About X axis	About Y axis	
JR 25	1.90	0.51	0.69	0.21	19.5
JR 35	4.26	1.32	1.43	0.49	24.3
JR 45	12.1	3.66	3.31	1.04	33.1
JR 55	27.6	6.54	5.89	1.40	43.3

**THK A1-325**

## Types and Features

### Model JR-A

The flange of its LM block has tapped holes.

Specification Table⇒ **A1-328**

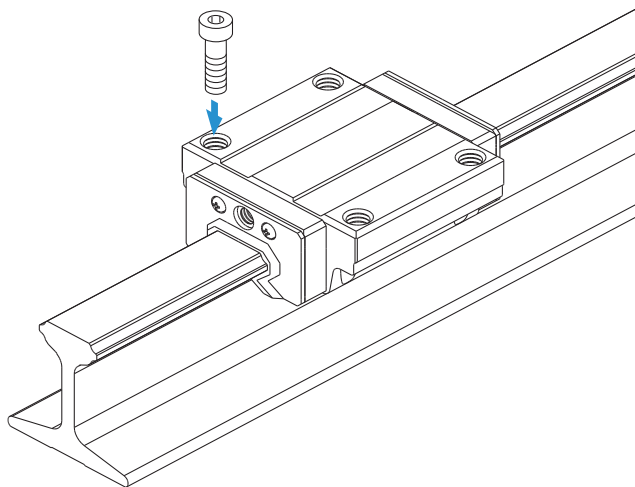

### Model JR-B

The flange of the LM block has through holes. Used in places where the table cannot have through holes for mounting bolts.

Specification Table⇒ **A1-328**

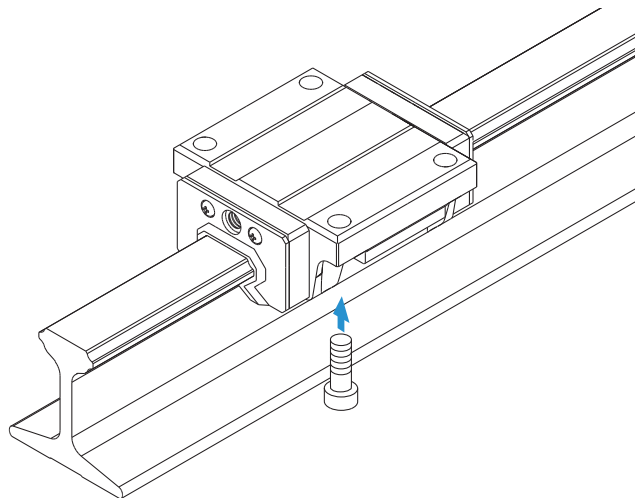

### Model JR-R

With this type, the LM block has a smaller width (W) and tapped holes. Used in places where the space for table width is limited.

Specification Table⇒ **A1-328**

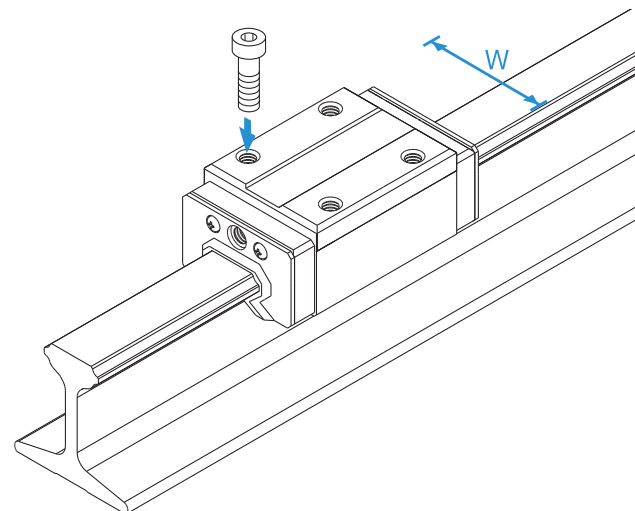

**A1-326 THK**

**THK A1-327**

## Models JR-A, JR-B and JR-R

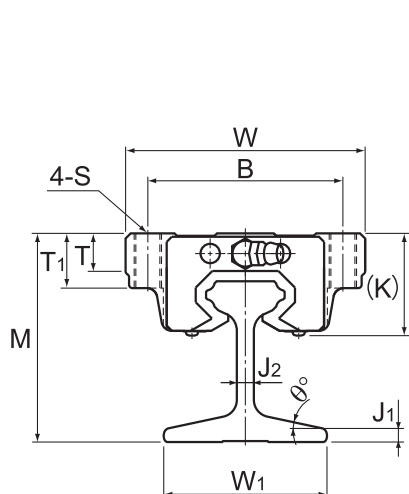

Models JR25 and 35A

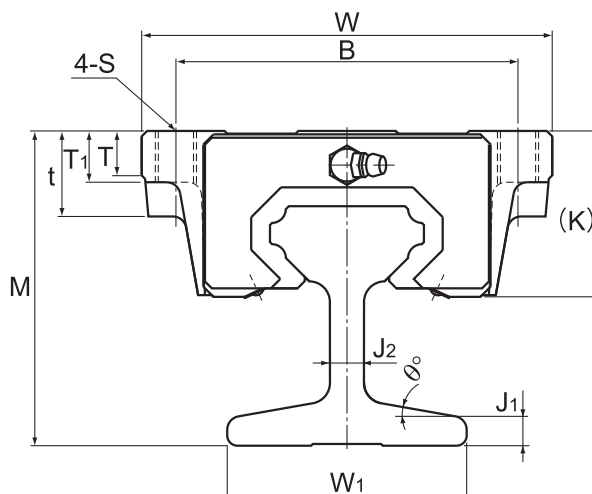

Models JR45 and 55A

Model No.	Outer dimensions			LM block dimensions											Grease nipple
	Height	Width	Length	B	C	H	S × ℓ	L <sub>1</sub>	t	T	T <sub>1</sub>	K	N	E	
	M	W	L												
JR 25A	61	70	83.1	57	45	—	M8*	59.5	—	11	16	30.5	6	12	B-M6F
JR 25B	61	70		57	45	7	—		16	11	10	30.5	6		
JR 25R	65	48		35	35	—	M6 × 8		—	9	—	34.5	10		
JR 35A	73	100	113.6	82	62	—	M10*	80.4	—	12	21	40	8	12	B-M6F
JR 35B	73	100		82	62	9	—		21	12	13	40	8		
JR 35R	80	70		50	50	—	M8 × 12		—	11.7	—	47.4	15		
JR 45A	92	120	145	100	80	—	M12*	98	25	13	15	50	10	16	B-PT1/8
JR 45B	92	120		100	80	11	—		25	13	15	50	10		
JR 45R	102	86		60	60	—	M10 × 17		—	15	—	59.4	20		
JR 55A	114	140	165	116	95	—	M14*	118	29	13.5	17	57	11	16	B-PT1/8
JR 55B	114	140		116	95	14	—		29	13.5	17	57	11		
JR 55R	124	100		75	75	—	M12 × 18		—	20.5	—	67	21		

Note) "\*" indicates a through hole.

### Model number coding

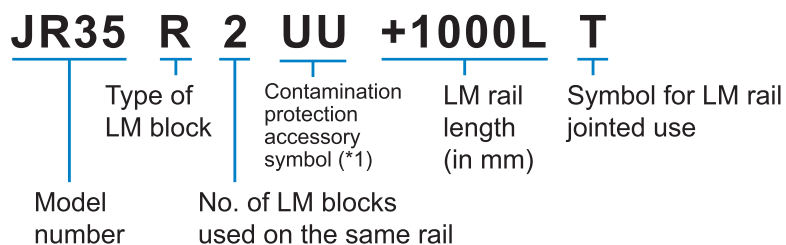

(\*1) See contamination protection accessory on **A1-524**

**A1-328 THK**

Download data by searching for the corresponding model number on the Technical Support site.

<https://tech.thk.com>

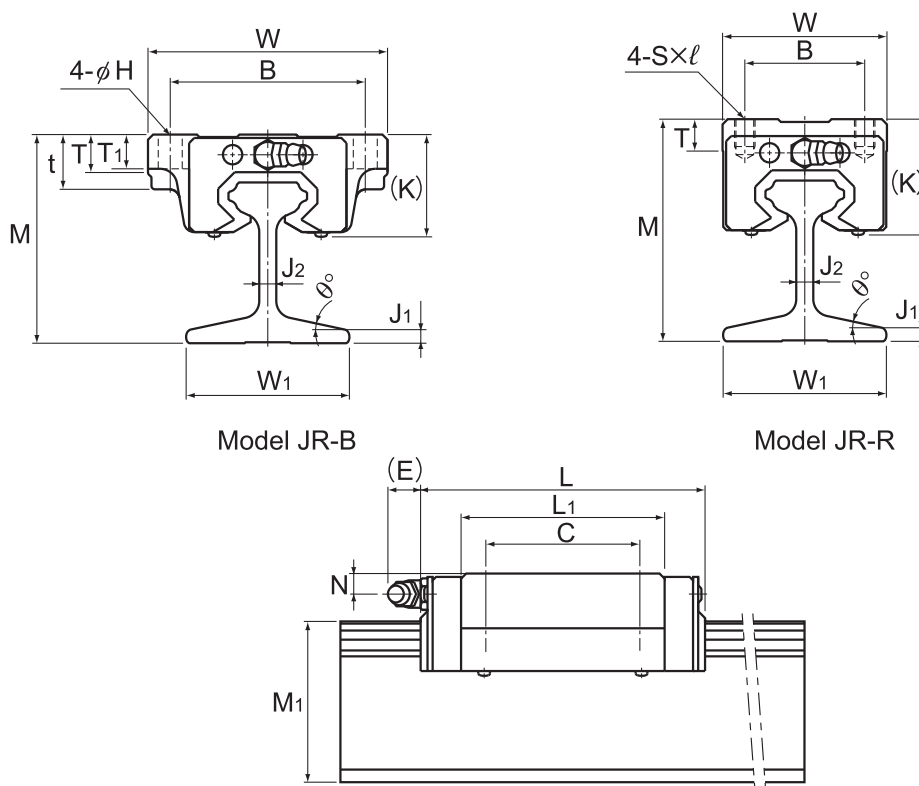

Unit: mm

	LM rail dimensions						Basic load rating		Static permissible moment kN·m*					Mass	
	Width W <sub>1</sub>	J <sub>1</sub>	J <sub>2</sub>	θ°	Height M <sub>1</sub>	Length* Max	C kN	C <sub>0</sub> kN	M <sub>A</sub>		M <sub>B</sub>		M <sub>C</sub>	LM block kg	LM rail kg/m
									1 block	Double blocks	1 block	Double blocks			
	48	4	5	12	47	2000	27.6	36.4	0.324	1.8	0.324	1.8	0.366	0.59 0.59 0.54	4.2
	54	7	8	10	54	4000	53.9	70.2	0.895	4.51	0.895	4.51	1.05	1.6 1.6 1.5	8.6
	70	8	10	10	70	4000	82.2	101	1.5	8.37	1.5	8.37	1.94	2.8 2.8 2.6	15.2
	93	4.8	11.6	12	90	4000	121	146	2.6	14.1	2.6	14.1	3.43	4.5 4.5 4.3	18.3

Note) The maximum length under "Length\*" indicates the standard maximum length of an LM rail. (See **A1-330**.)

Static permissible moment\*

1 block: the static permissible moment with one LM block

Double blocks: static permissible moment when two LM blocks are in close contact with each other

Total block length L

: The total block length L shown in the table is the length with the dust proof parts, code UU or SS. If other contamination protection accessories or lubricant equipment are installed, the total block length will increase.

(See **A1-499** or **A1-520**)

Options⇒ **A1-485**

**THK A1-329**

## Standard Length and Maximum Length of the LM Rail

Table1 shows the standard lengths and the maximum lengths of model JR variations. If the maximum length of the desired LM rail exceeds them, jointed rails will be used. Contact THK for details.

Table1 Standard Length and Maximum Length of the LM Rail for Model JR

Unit: mm

Model No.	JR 25	JR 35	JR 45	JR 55
LM rail standard length ( $L_0$ )	1000	1000	1000	1000
	1500	2000	2000	2000
	2000	4000	4000	4000
Max length	2000	4000	4000	4000

Note1) If jointed rails are not allowed and a greater length than the maximum values above is required, contact THK.

Note2) For jointing two or more rails, a metal fitting like the one shown in Fig.3 is available. For the mounting method, see **B1-99**.

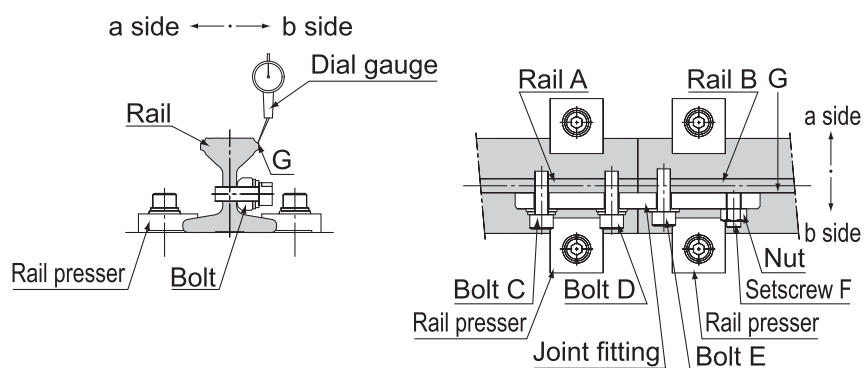
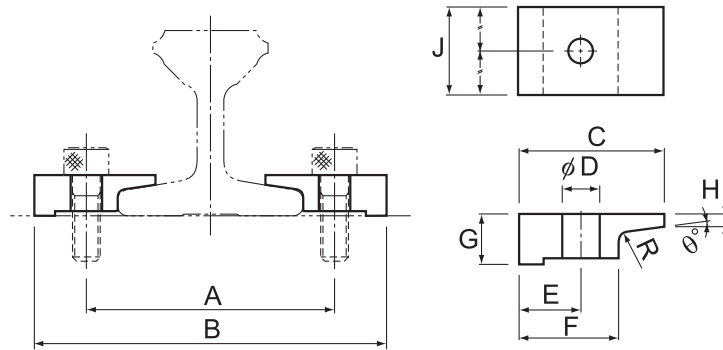

Fig.3

**A1-330 THK**

## Model JB frame for LM rail clamps



Unit: mm

Model No.	Mounting dimensions		Clamper dimensions									Bolt used
	A	B	C	D	E	F	G	H	R	J	$\theta^\circ$	
JB 25	57	78	25	7	10.5	15	10	3.8	R2	25	10	M 6
JB 35	72	102	35	9	15	24	12	3.1	R2	32	8	M 8
JB 45	90	130	45	11	20	30	16	5.4	R2	40	8	M10
JB 55	115	155	50	14	20	30	17	8.2	R2	50	10	M12

## Model JT steel plate for LM rail clamps

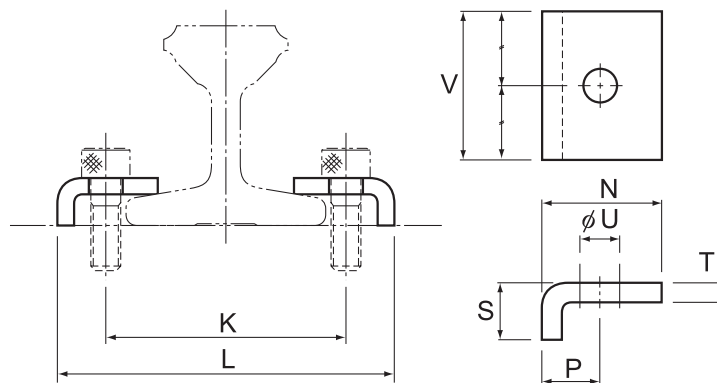

Unit: mm

Model No.	Mounting dimensions		Clamper dimensions						Bolt used
	K	L	N	P	S	T	U	V	
JT 25	57	79	25	11	10	4	7	25	M 6
JT 35	65	91	27	13	13	4.5	9	40	M 8
JT 45	84	114	33	15	16	6	11	50	M10
JT 55	110	148	50	19	15	6	14	50	M12

**THK A1-331**