

Rotary Ball Spline

With Geared Type Models LBG and LBGT

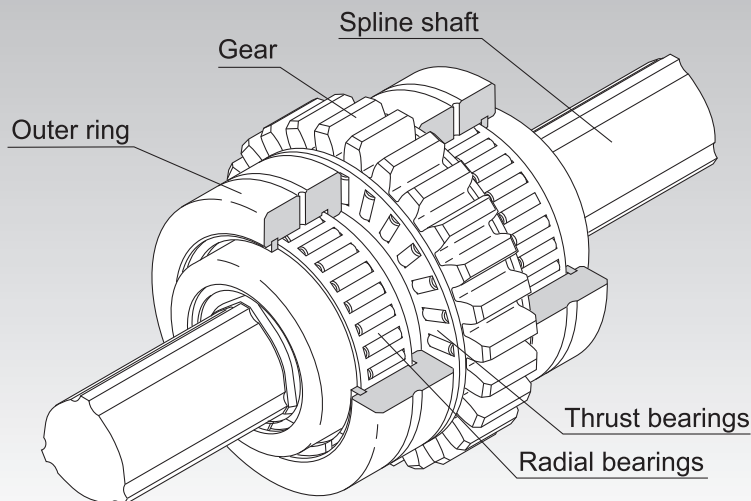

Fig.1 Structure of Rotary Ball Spline Model LBG

Point of Selection	A3-6
Point of Design	A3-123
Options	A3-126
Model No.	A3-128
Precautions on Use	A3-129
Accessories for Lubrication	A24-1
Mounting Procedure and Maintenance	B3-31
Cross-sectional Characteristics of the Spline Shaft	A3-17
Equivalent factor	A3-27
Clearance in the Rotation Direction	A3-30
Accuracy Standards	A3-35
Maximum Manufacturing Length by Accuracy	A3-121

A3-98 **THK**

Structure and Features

With the Rotary Ball Spline, the spline shaft has three crests, and along both sides of each crest, two rows of balls (six rows in total) are arranged to hold the crest so that a reasonable preload is applied.

These models are unit types based on model LBR, but have gear teeth on the flange circumference and radial and thrust bearings on the spline nut, all compactly integrated.

The rows of balls are held in a special resin retainer so that they smoothly roll and circulate. With this design, balls will not fall even if the spline shaft is removed.

[No Angular Backlash]

The spline shaft has three crests positioned equidistantly at 120° and along both sides of each crest, two rows of balls (six rows in total) are arranged so as to hold the crest at a contact angle of 45° and provide a preload. As a result, backlash in the rotational direction is eliminated and the rigidity is increased.

[Compact Design]

The spline nut is compactly integrated with radial and thrust bearings, allowing compact design to be achieved.

[High Rigidity]

Since the contact angle is large and an appropriate preload is given, high rigidity against torque and moment is achieved.

Use of needle bearings in the support unit achieves a rigid nut support strong against a radial load.

[Optimal for Torque Transmission with Spline Nut Drive]

Since the support bearings allow a rigid nut support, these models are optimal for torque transmission with spline nut drive.

Types and Features

[Types of Spline Nuts]

Ball Spline with Gears Model LBG

Specification Table⇒ **A3-102**

These models are unit types based on model LBR, but have gear teeth on the flange circumference and radial and thrust bearings on the spline nut, all compactly integrated. It is optimal for a torque transmission mechanism with spline nut drive.

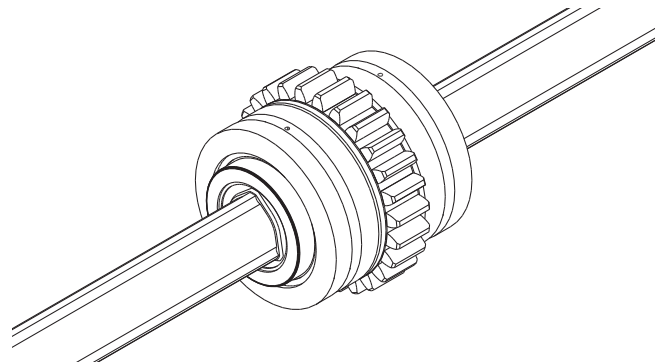

Without a thrust raceway

Ball Spline with Gears Model LBGT

Specification Table⇒ **A3-104**

These models are unit types based on model LBR, but have gear teeth on the flange circumference and radial and thrust bearings on the spline nut, all compactly integrated. It is optimal for a torque transmission mechanism with spline nut drive.

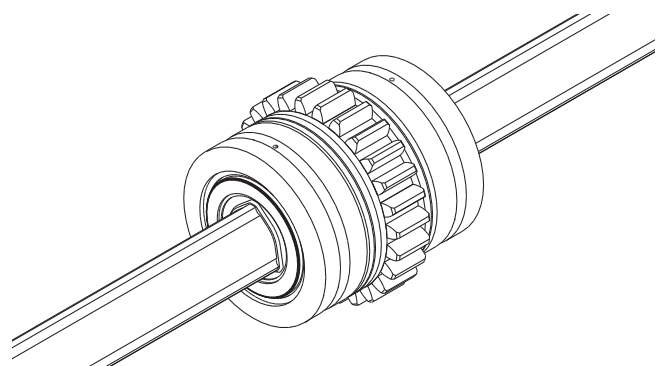

With a thrust raceway

[Types of Spline Shafts]

For details, see **A3-57**.

A3-100 **THK**

Housing Inner-diameter Tolerance

Table1 shows housing inner-diameter tolerance for models LBG and LBGT.

Table1 Housing Inner-diameter Tolerance

Housing Inner-diameter Tolerance	General conditions	H7
	When clearance needs to be small	J6

THK **A3-101**

Model LBG

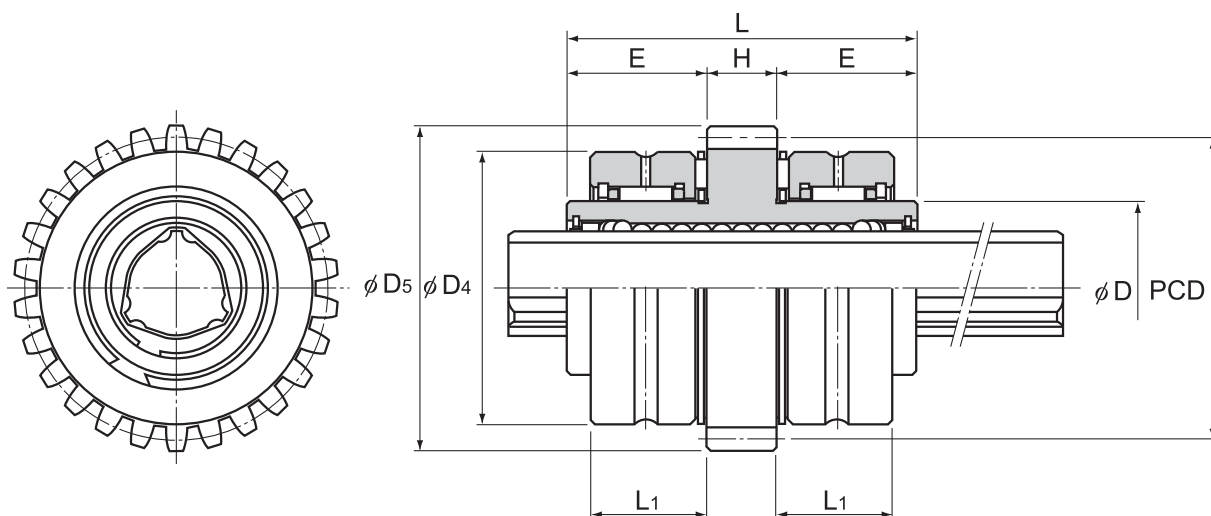

Model No.	Spline nut dimensions									
	Spline nut outer diameter		Length		Outer diameter		Width		H	E
	D	Tolerance	L	Tolerance	D ₄	Tolerance	L ₁	Tolerance		
● LBG 20	30	$\begin{matrix} 0 \\ -0.009 \end{matrix}$	60	$\begin{matrix} 0 \\ -0.2 \end{matrix}$	47	$\begin{matrix} 0 \\ -0.011 \end{matrix}$	20	$\begin{matrix} 0 \\ -0.16 \end{matrix}$	12	24
● LBG 25	40	$\begin{matrix} 0 \\ -0.011 \end{matrix}$	70		60	$\begin{matrix} 0 \\ -0.013 \end{matrix}$	23	$\begin{matrix} 0 \\ -0.19 \end{matrix}$	14	28
● LBG 30	45	$\begin{matrix} 0 \\ -0.013 \end{matrix}$	80		65	$\begin{matrix} 0 \\ -0.015 \end{matrix}$	27	$\begin{matrix} 0 \\ -0.25 \end{matrix}$	16	32
● LBG 40	60	$\begin{matrix} 0 \\ -0.013 \end{matrix}$	100	$\begin{matrix} 0 \\ -0.3 \end{matrix}$	85	$\begin{matrix} 0 \\ -0.015 \end{matrix}$	31	$\begin{matrix} 0 \\ -0.25 \end{matrix}$	18	41
● LBG 50	75	$\begin{matrix} 0 \\ -0.015 \end{matrix}$	112		100	$\begin{matrix} 0 \\ -0.025 \end{matrix}$	32	$\begin{matrix} 0 \\ -0.25 \end{matrix}$	20	46
● LBG 60	90	$\begin{matrix} 0 \\ -0.015 \end{matrix}$	127		120	$\begin{matrix} 0 \\ -0.025 \end{matrix}$	38	$\begin{matrix} 0 \\ -0.25 \end{matrix}$	22	52.5
● LBG 85	120	$\begin{matrix} 0 \\ -0.015 \end{matrix}$	155		150	$\begin{matrix} 0 \\ -0.025 \end{matrix}$	40	$\begin{matrix} 0 \\ -0.25 \end{matrix}$	26	64.5

Note) ●: indicates model numbers for which felt seal types are available (see **A3-126**).

Model number coding

2 LBG50 UU CM +700L H K

2: Number of spline nuts on one shaft (no symbol for one nut)
 LBG50: Model No.
 UU: Contamination protection accessory symbol (*1)
 CM: Symbol for clearance in the rotational direction (*2)
 +700L: Overall spline shaft length (in mm) (*5)
 H: Accuracy symbol (*3)
 K: Symbol for spline shaft (*4)

(*1) See **A3-126**. (*2) See **A3-30**. (*3) See **A3-35**. (*4) See **A3-106**. (*5) See **A3-121**.

A3-102 THK

Download data by searching for the corresponding model number on the Technical Support site.

<https://tech.thk.com>

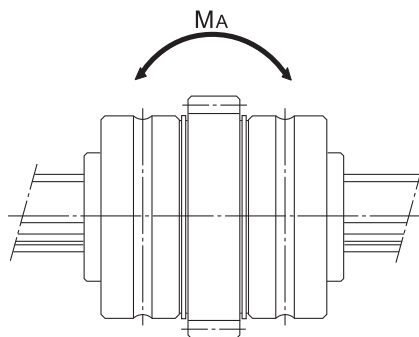

Unit: mm

	Gear specifications*				Basic torque rating		Basic load rating		Static permissible moment	Mass	
	Tip circle diameter D_s	Standard pitch diameter PCD	Module m	Number of teeth z	C_T N·m	C_{OT} N·m	C kN	C_0 kN	M_A^{**} N·m	Spline nut unit kg	Spline shaft kg/m
	56	52	2	26	90.2	213	9.4	20.1	103	0.61	1.8
	70	65	2.5	26	176	381	14.9	28.7	171	1.4	2.7
	75	70	2.5	28	312	657	22.5	41.4	295	2.1	3.8
	96	90	3	30	696	1420	37.1	66.9	586	3	6.8
	111	105	3	35	1290	2500	55.1	94.1	941	4.1	10.6
	133	126	3.5	36	1870	3830	66.2	121	1300	6.3	15.6
	168	160	4	40	4740	9550	119	213	3180	11.8	32

Note) *The gear specifications in the table represent the dimensions with maximum module.

Special gear types such as helical gear and worm gear can also be manufactured at your request.

** M_A indicates the permissible moment value in the axial direction when a single spline nut is used, as shown in the figure above.

For details on the maximum lengths of ball spline shafts by accuracy, please see **A3-121**.

Options ⇒ **A3-126****THK A3-103**

Model LBGT

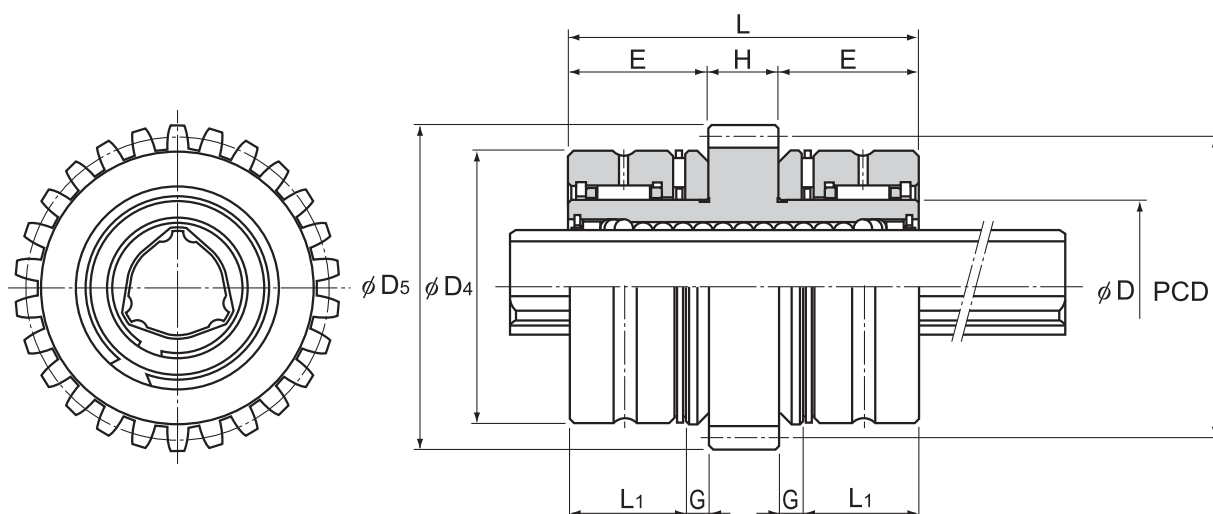

Model No.	Spline nut dimensions										
	Spline nut outer diameter		Length		Outer diameter		Width		Thrust raceway width	H	E
	D	Tolerance	L	Tolerance	D ₄	Tolerance	L ₁	Tolerance			
● LBGT 20	30	0 -0.009	60	0 -0.2	47	0 -0.011	20	0 -0.16	4	12	24
● LBGT 25	40	0	70		60	0	23	0	5	14	28
● LBGT 30	45	-0.011	80		65	-0.013	27	-0.19	5	16	32
● LBGT 40	60	0	100	0 -0.3	85	0 -0.015	31	0 -0.25	8	18	41
● LBGT 50	75	-0.013	112		100		32		10	20	46
LBGT 60	90	0	127		120	38	12		22	52.5	
● LBGT 85	120	-0.015	155		150	0 -0.025	40		16	26	64.5

Note) ●: indicates model numbers for which felt seal types are available (see **A3-126**).

Model number coding

2 LBGT40 UU CL +700L P K

2: Number of spline nuts on one shaft (no symbol for one nut) (*1)
 LBGT40: Model No.
 UU: Contamination protection accessory symbol (*2)
 CL: Symbol for clearance in the rotational direction (*2)
 +700L: Overall spline shaft length (in mm) (*5)
 P: Accuracy symbol (*3)
 K: Symbol for spline shaft (*4)

(*1) See **A3-126**. (*2) See **A3-30**. (*3) See **A3-35**. (*4) See **A3-106**. (*5) See **A3-121**.

A3-104 THK

Download data by searching for the corresponding model number on the Technical Support site.

<https://tech.thk.com>

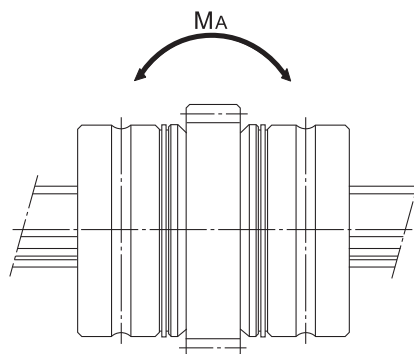

Unit: mm

	Gear specifications*				Basic torque rating		Basic load rating		Static permissible moment	Mass	
	Tip circle diameter D_s	Standard pitch diameter PCD	Module m	Number of teeth z	C_T N·m	C_{OT} N·m	C kN	C_0 kN	M_A^{**} N·m	Spline nut unit kg	Spline shaft kg/m
	56	52	2	26	90.2	213	9.4	20.1	103	0.67	1.8
	70	65	2.5	26	176	381	14.9	28.7	171	1.5	2.7
	75	70	2.5	28	312	657	22.5	41.4	295	2.2	3.8
	96	90	3	30	696	1420	37.1	66.9	586	3.3	6.8
	111	105	3	35	1290	2500	55.1	94.1	941	4.8	10.6
	133	126	3.5	36	1870	3830	66.2	121	1300	7.2	15.6
	168	160	4	40	4740	9550	119	213	3180	13.4	32

Note) *The gear specifications in the table represent the dimensions with maximum module.

Special gear types such as helical gear and worm gear can also be manufactured at your request.

** M_A indicates the permissible moment value in the axial direction when a single spline nut is used, as shown in the figure above.

For details on the maximum lengths of ball spline shafts by accuracy, please see **A3-121**.

Options⇒ **A3-126****THK A3-105**

Spline Shaft

Spline shafts are divided in shape into precision solid spline shaft, special spline shaft and hollow spline shaft (type K), as described on **A3-57**.

Since production of a spline shaft with a specific shape is performed at your request, provide a drawing of the desired shaft shape when asking an estimate or placing an order.

[Sectional Shape of the Spline Shaft]

Table2 shows the sectional shape of a spline shaft. If the spline shaft ends need to be cylindrical, the minor diameter (ϕd) value should not be exceeded if possible.

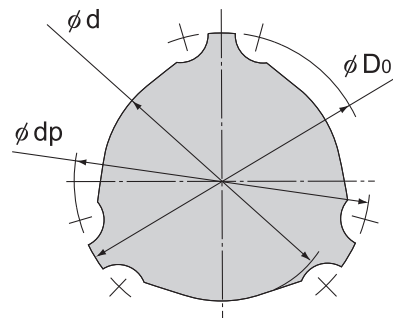

Table2 Sectional Shape of the Spline Shaft

Unit: mm

Nominal shaft diameter	20	25	30	40	50	60	85
Minor diameter ϕd	15.3	19.5	22.5	31	39	46.5	67
Major diameter ϕD_0	19.7	24.5	29.6	39.8	49.5	60	84
Ball center-to-center diameter ϕdp	20	25	30	40	50	60	85
Mass (kg/m)	1.8	2.7	3.8	6.8	10.6	15.6	32

*The minor diameter ϕd must be a value at which no groove is left after machining.

[Hole Shape of the Standard Hollow Type Spline Shaft]

Table3 shows the hole shape of the standard hollow type spline shaft (type K) for models LBG and LBGT.

Use this table when a requirement such as piping, wiring, air-vent or weight reduction needs to be met.

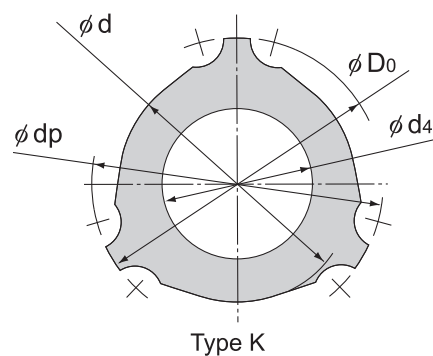

Table3 Sectional Shape of the Standard Hollow Type Spline Shaft

Unit: mm

Nominal shaft diameter	20	25	30	40	50	60	85
Minor diameter ϕd	15.3	19.5	22.5	31	39	46.5	67
Major diameter ϕD_0	19.7	24.5	29.6	39.8	49.5	60	84
Ball center-to-center diameter ϕdp	20	25	30	40	50	60	85
Hole diameter ϕd_4	6	8	12	18	24	30	45
Mass (kg/m)	1.6	2.3	2.9	4.9	7	10	19.5

*The minor diameter ϕd must be a value at which no groove is left after machining.

A3-106 THK

[Chamfering of the Spline Shaft Ends]

To facilitate the insertion of the spline shaft into a spline nut, the shaft ends are normally chamfered with the dimensions indicated below unless otherwise specified.

● Chamfer A

If the spline shaft ends are stepped, tapped, or drilled as in Fig. 2, they are machined with the Chamfer A dimensions indicated in Table 4.

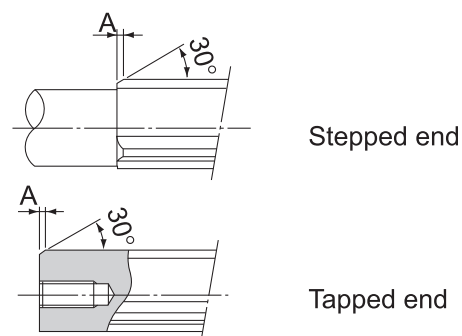

Fig. 2 Chamfer A

● Chamfer B

If either end of the spline shaft is not used, such as for cantilever support, it is machined with the Chamfer B dimensions indicated in Table 4.

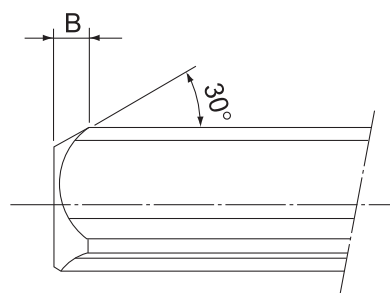

Fig. 3 Chamfer B

Table 4 Chamfer Dimensions of Spline Shaft Ends

Unit: mm

Nominal shaft diameter	20	25	30	40	50	60	85
Chamfer A	1	1.5	2.5	3	3.5	5	7
Chamfer B	4.5	5.5	7	8.5	10	13	16

Note) Spline shafts with nominal diameters 6, 8, and 10 are chamfered to C0.5.

[Length of Imperfect Area of a Special Spline Shaft]

If the middle area or the end of a spline shaft is to be thicker than the minor diameter (ϕd), an imperfect spline area is required to secure a recess for grinding. Table5 shows the relationship between the length of the incomplete section (S) and the flange diameter (ϕdf).

(This table does not apply to overall length of 1,500 mm or greater. Contact THK for details.)

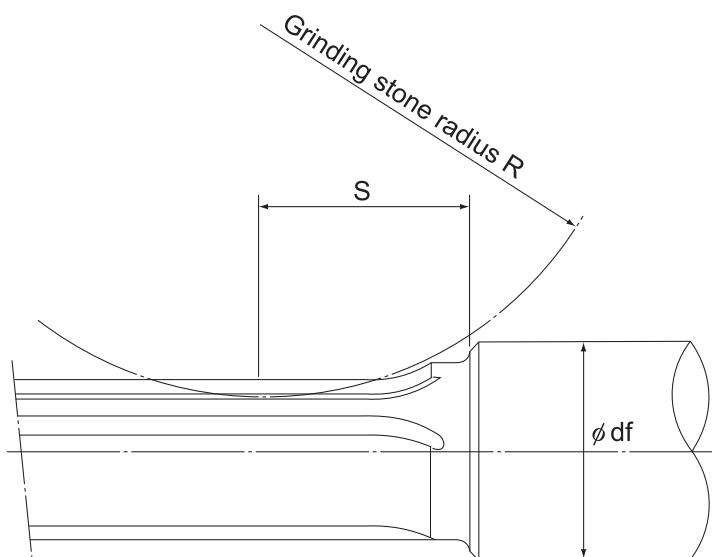

Table5 Length of Imperfect Spline Area: S

Unit: mm

Flange diameter ϕdf	20	25	30	35	40	50	60	80	100	120	140
Nominal shaft diameter	20	25	30	35	40	50	60	80	100	120	140
20	35	43	51	57	62	—	—	—	—	—	—
25	—	51	64	74	82	97	—	—	—	—	—
30	—	—	54	67	76	92	105	—	—	—	—
40	—	—	—	—	59	80	95	119	—	—	—
50	—	—	—	—	—	63	83	110	131	—	—
60	—	—	—	—	—	—	66	100	123	140	—
70	—	—	—	—	—	—	—	89	115	134	150
85	—	—	—	—	—	—	—	61	98	122	140

A3-108 THK

THK A3-109