



HENNLICH

MERES

CCON25-100

Cold applied conduit connection kit

PRODUCT OVERVIEW

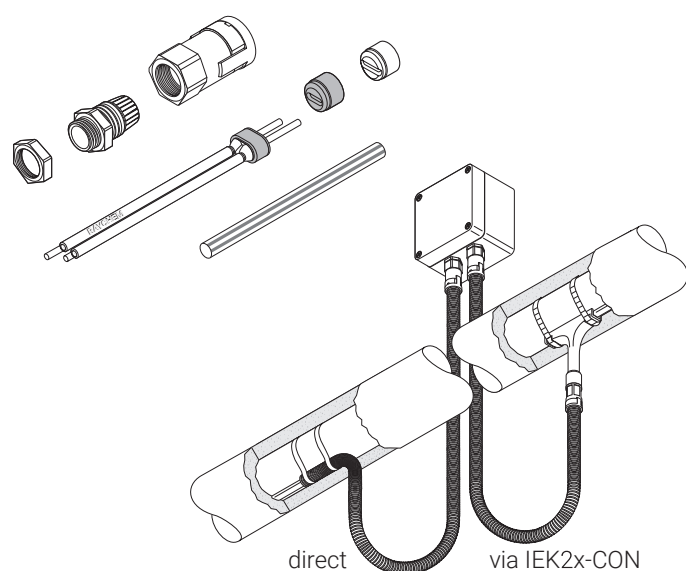

This connection kit is designed for terminating all nVent RAYCHEM BTV, QTVR, XTV, KTV and VPL parallel industrial heating cables to a junction box, whilst maintaining electrical insulation of the heating cable conductors and core as well as providing a reliable and sealed connection to a conduit system. It is approved for use in hazardous locations.

The conduit system will provide supplementary mechanical protection of the heating cable between a junction box and the entry into the insulation. The conduit connection is fast and reliable and allows simple installation whilst maintaining an IP66 seal. The kit can be used with various types of conduits which can be cut-to-length as required in the field. The core sealing boot for the heating cable does not require a heat gun or torch for the installation (no need for a hot work permit). The non-curing sealant (silicone free) allows easy installation and facilitates maintenance purposes.

The conduit and eventually required insulation entry kit needs to be purchased separately.

Application

Connection kit with conduit adaptor for BTV, QTVR, XTV, KTV and VPL parallel industrial heating cables

Kit contents

- 1 gland body,
- 1 conduit adaptor including safety retention clip,
- 2 grommets,
- 1 locknut,
- 1 core sealer,
- 1 green/yellow tube,
- 1 installation instruction (multilingual)

PRODUCT SPECIFICATION

Technical details

Thread size	M25 x 1.5
Conduit compatibility	ND 23 mm, nVent RAYCHEM conduits type CCON25-C...
Ambient temperature	-55°C to +40°C
IP ingress protection rating	IP66
Surface resistance	< 1GΩ according to the requirements of EN 60079-0 and EN 61241-0 for use in hazardous areas



APPROVALS

For use in ordinary and hazardous area Zone 1 and Zone 2 (Gas), Zone 21 and Zone 22 (Dust)

Temperature classification

Temperature classification is defined by the complete system.

Product certification



More details about product certification, approvals and conditions of safe use are available in the installation manual at www.nVent.com/RAYCHEM.

ORDERING INFORMATION

Part description	nVent RAYCHEM CCON25-100
PN (weight)	1244-003272 (0.075 kg)

Accessories

For suitable conduits and insulation entry kits refer to the datasheet for CCON2x-C...

