



HENNLICH

MERES

CS-150-UNI-PI

Cold applied low profile power connection

PRODUCT OVERVIEW

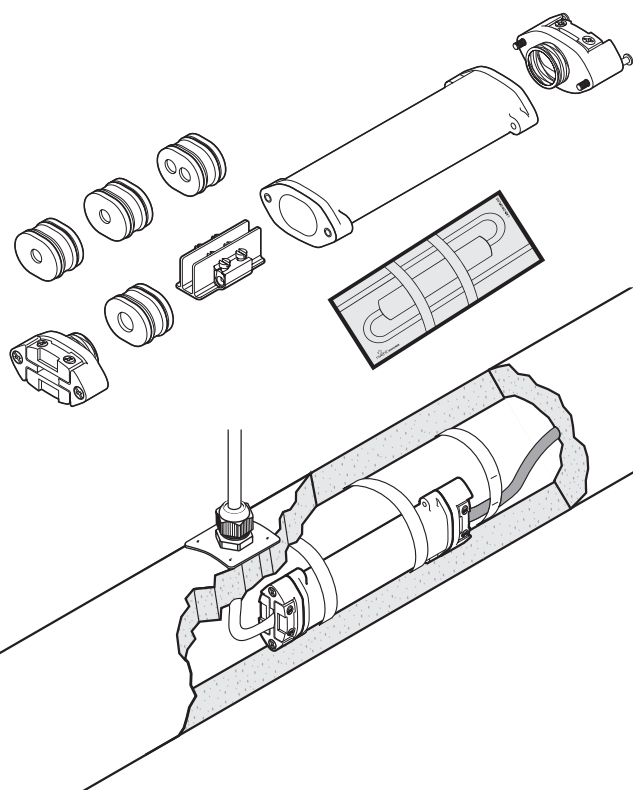

The nVent RAYCHEM CS-150-UNI-PI is a universal low profile heating cable connector for the direct connection of single conductor Polymer Insulated (PI) series heating cables. It can be used in different configurations: for the connection of a cold lead to a heating cable (Variant C), as an under insulation connecting system for the connection of a three core power cable to a heating cable loop (Variant L), as well as for splicing two heating cables (Variant S).

The connector is certified for use in hazardous areas and doesn't require a hot work permit. The electrical connection is realized by means of screw terminals, so no special crimp tools are required. If used as a connection kit, an additional gland needs to be ordered separately.

Application

"Cold" applied connection/splice for a single conductor polymer insulated (PI) series heating cables with an external diameter between 3.2 and 6.4 mm. In hazardous area use only with ATEX approved heating cable.

The CS-150-UNI-PI can be used in different configurations:

- Connection of a heating cable to a cold lead cable 1 x 2.5 mm² or 1 x 4 mm² (Variant C)
- Connection of a heating cable to a power cable 3 x 2.5 mm² (Variant L)
- Splice of two heating cables (Variant S)

Kit contents

- 1 x temperature resistant and impact proof body
- 1 x screw terminal block
- 4 x rubber seals (to be used according to application)
- 2 x strain relieve clamps with screws
- 1 x identification label
- 1 x tube of lubricant
- 1 x installation instruction

PRODUCT SPECIFICATIONS

Dimensions (in mm)

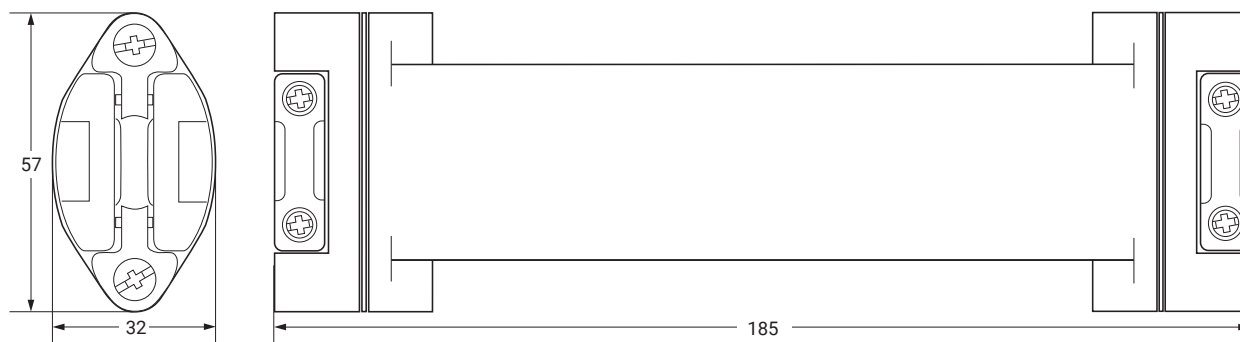

Heating cable types

Heating cable capability	XPI-F, XPI and XPI-S polymer insulated (PI) series resistance cable, for other types contact nVent.
--------------------------	---

Materials of construction

Housing, connection	Glass fibre reinforced temperature resistant engineering plastic
Support ring, spacer, screws and spring	Stainless steel
Cable seals	Silicon rubber

Technical Details

Maximum operating temperature (*)	Power on: 180°C (may be limited by the temperature resistance of the supply cable) Power off: 200°C (using variant L, dependent on the type of supply cable e.g. 200°C for silicon cables, unless the power cable connection is bent sufficiently far away from the heated surface).
Minimum installation temperature	-50°C
Max. operating voltage	Variant C and S = 750 Vac Variant L = 420 Vac
Max. allowed wattage	The max. allowed cable output is limited depending on the application. Refer to the installation instruction for details.
Max. permitted nominal current (*)	Variant S: 32 A Variant C with 1 x 2.5 mm ² supply cable: 25 A Variant C with 1 x 4 mm ² supply cable: 32 A Variant L with 3 x 2.5 mm ² supply cable up to 150°C: 25 A Variant L with 3 x 2.5 mm ² supply cable 151°C to 180°C: 20 A

Supply cable dimensions

- Multi-stranded copper conductors 3 x 2.5 mm², Ø 6.8–12.6 mm
- Single conductor cold lead, max. 1 x 4 mm², Ø 3.2–6.4 mm

Supply cable requirements

The maximum permissible voltage drop is to be taken into consideration when selecting the cross-section of the power cable. The maximum working temperature of the CS-150-UNI-PI can be reduced through the maximum permitted continuous use temperature of the supply cable, unless the supply cable is laid (at a sufficient distance from the heated surface) so that the maximum permitted continuous use temperature will not be exceeded. A suitable power cable is the silicon insulated cable type C-150-PC.

APPROVALS

For use in ordinary and hazardous area Zone 1 and Zone 2 (Gas), Zone 21 and Zone 22 (Dust)

Temperature classification

Particular measures to maintain the T-classification of polymer insulated heating cables are to be taken in accordance with the appropriate EC - Type examination certificate (also refer to installation instructions).

Type examination certification applies for the use of ATEX certified polymer insulated (PI) series heating cables.

The temperature class will depend on the system.

Product certification



More details about product certification, approvals and conditions of safe use are available in the installation manual at www.nVent.com/RAYCHEM.

ORDERING INFORMATION

Order reference CS-150-UNI-PI

Part number (Weight) A45371-000 (0.4 kg)

(* For the full range of technical design details of the CS-150-UNI-PI refer to the installation instructions (INSTALL-064)

Accessories

Cable gland GL-55-M25 hazardous area approved gland for, 8–15 mm, up to –55°C

Glands for PI heaters C20-PI-PA-KIT Hazardous area approved gland, PA, up to –40°C

C20-PI-M0-KIT Hazardous area approved gland, Ni plated brass, up to –55°C
(to be used with boxes with integral earth plate or with earth lug)