



HENNLICH

MERES

High Range Two Axes Ultrasonic Anemometer HD51.3D - series

WIDE AVAILABILITY OF MODELS FOR ALL NEEDS

Basic models with **Wind Speed & Wind Direction** or 'All-in-One' with additional **Temperature, Relative Humidity, Atmospheric Pressure and Solar Radiation**

HIGH RANGE WIND MEASUREMENT

Capable of measuring **wind speed up to 85 m/s** without giving up

HIGH PERFORMANCE FOR HARSH ENVIRONMENTS

Heavy duty mechanical design. Models with **integrated heating**. Ultrasonic sensor with **no moving parts**.
Minimized maintenance.

ACCURATE AND RELIABLE SYSTEM

All **sensors** are **factory-calibrated** and do not require additional interventions of the user.

GREAT FLEXIBILITY IN OUTPUT CHOICE

RS232, RS485 and RS422 isolated serial outputs.
NMEA and MODBUS-RTU standard protocols and **ASCII** proprietary protocol.

Two analog output for wind speed and direction or for velocity U-V cartesian components.



*HD51.3DP147
High range multiparameter*



*HD51.3DR-AL for
harsh environments*

Main Application Fields

Wind farms monitoring

Remote weather stations

Buildings, constructions and bridges control

Ports, airports and heliports

Road and railway tunnels

HIGH RANGE WIND SPEED? APPLICATIONS IN HARSH ENVIRONMENTS? HD51.3D SERIES IS DESIGNED FOR THE PURPOSE!

Measurements of wind speed and wind direction have become of very high importance in many fields. Automatic Weather Stations (AWS) are probably where we are mostly used to see anemometers in action but it is definitely not the only application for wind measurement. Let's think for example about the importance of accurately knowing wind gust, wind speed and wind direction when it comes to wind measurements on a port, a harbor or an off-shore application.

Delta OHM already boasts a wide range of wind measurement sensors. The **HD51.3D series** has been developed as a result of an increasing professional market demand for **higher ranges of measurements**. Worldwide, changes of climate and more extreme occurring situation have caused this movement toward higher ranges.

The HD51.3D series is **the result of our own R&D**. The **top model** of this series in anodized aluminium alloy can even **withstand an extreme wind speed of 100 m/s without giving up!**

A lot of attention has been paid to the mechanical design: thanks to a **heavy duty design and no moving parts**, maintenance is minimized. An **anti-corrosion coating** allows the aluminium versions to be used even in particularly aggressive atmosphere. An **enhanced heater** (or optional for the models with housing in technopolymer) grants rapid defrosting and accurate measurement in all environmental conditions.

The optional function of detecting the orientation (compass) and tilt angles allows the spatial orientation of the instrument to be determined at any time, allowing installation on mobile vehicles (e.g. boats) or, in the case of fixed installations, the automatic correction of both a possible misalignment with respect to the vertical axis and an imperfect orientation of the instrument towards the North.

The **high immunity to electromagnetic disturbances** makes the anemometer suitable for measurements in electrically noisy environments such as industrial environments or wind farms.

All models satisfy the requirements of the **MIL-STD-810G Method 509.6** and **EN ISO 9227:2017** (salt fog anti-corrosion test). The versions with housing in anodized aluminium alloy also satisfy **MIL-STD-810F Method 521.2** (anti-icing/freezing rain test) and **EN 60945:2002 Sect. 8.7 / IEC 60068-2-6** (vibration resistance test).



Technical Specifications

WIND SPEED

Sensor	Ultrasounds
Measuring range	0...80 m/s (versions '-AL') 0...85 m/s (versions without T/RH) 0...75 m/s (versions with T/RH)
Resolution	0.01 m/s
Accuracy	± 0.2 m/s or ± 2% of measure, the greatest (0...65 m/s), ± 3% (> 65 m/s)

WIND DIRECTION

Sensor	Ultrasounds
Measuring range	0...359.9°
Resolution	0.1°
Accuracy	± 2° RMSE wind speed > 2 m/s

AIR TEMPERATURE* (option 17)

Sensor	Pt100
Measuring range	-40...+70 °C
Resolution	0.1 °C
Accuracy	± 0.15 °C ± 0.1% of measure

RELATIVE HUMIDITY* (option 17)

Sensor	Capacitive
Measuring range	0...100 %RH
Resolution	0.1 %
Accuracy (@ T = 15...35 °C)	± 1.5 %RH (0...90 %RH), ± 2 %RH (remaining range)
Accuracy (@ T = -40...+70 °C)	± (1.5 + 1.5 % of measure) %RH

ATMOSPHERIC PRESSURE (option 4)

Sensor	Piezoresistive
Measuring range	300...1100 hPa
Resolution	0.1 hPa
Accuracy	±0.5 hPa (700...1100 hPa) @ 20 °C ±1 hPa (500...1100 hPa) @T = 0...60 °C ±1.5 hPa (300...500 hPa) @T = 0...60 °C

GLOBAL SOLAR RADIATION* (option P)

Sensor	Thermopile
Measuring range	0...2000 W/m ²
Resolution	1 W/m ²
Accuracy	Spectrally Flat Class C

COMPASS + TILT ANGLES (option A)

Resolution	0.05°
Accuracy	± 1°

HEATING (option R, always included in "-AL" models)

Heater power supply	24 Vdc ± 10%
Heater power consumption	15 W 80 W for '-AL' models

* These options are available only for models in technopolymer.

GENERAL FEATURES

Power supply (without heater)	12...30 Vdc
Power consumption (without heater)	60 mA @ 24 Vdc
Serial outputs	Isolated RS232, RS485 and RS422
Communication protocols	NMEA, MODBUS-RTU, ASCII proprietary
Analog outputs	2 analog outputs, for wind speed and direction or for velocity U-V cartesian components. Output at choice among 4...20 mA (standard), 0...1, 0...5 and 0...10 V
Measurement interval	From 250 ms to 1 s
Wind speed averaging interval	Configurable from 1 s to 10 min
Wind Gust calculation interval	Configurable from 1 s to 10 min
Electrical connection	19-pole M23 male connector
Operating temperature	-40...+70 °C -50...+70 °C**
Protection degree	IP 66
Anti-corrosion test	MIL-STD-810G Method 509.6 (48 hours of exposure + 48 hours of drying) EN ISO 9227:2017
Vibration resistance test**	MIL-STD-810F Method 521.2
Anti-icing/freezing rain test**	EN 60945:2002 Sect. 8.7 IEC 60068-2-6
Survival speed	90 m/s 100 m/s**
Weight	About 640 g (versions without T/RH) About 1 kg (versions with T/RH) About 1.4 kg (versions '-AL')
Case	ASA with aluminium and AISI 316 metal parts Anodized aluminium alloy and AISI 316**
Installation	on mast Ø 40 mm external and Ø 36 mm internal

** Specifications refer only to models in anodized aluminium alloy.



Dimensions (mm)

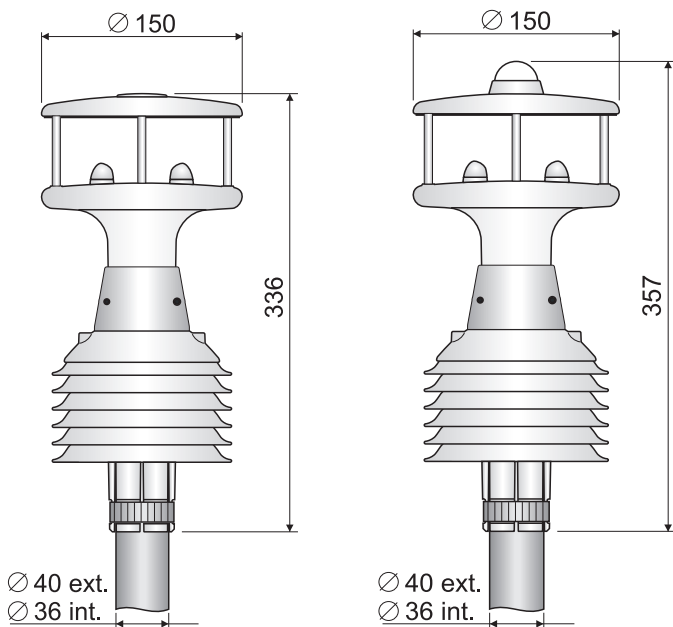
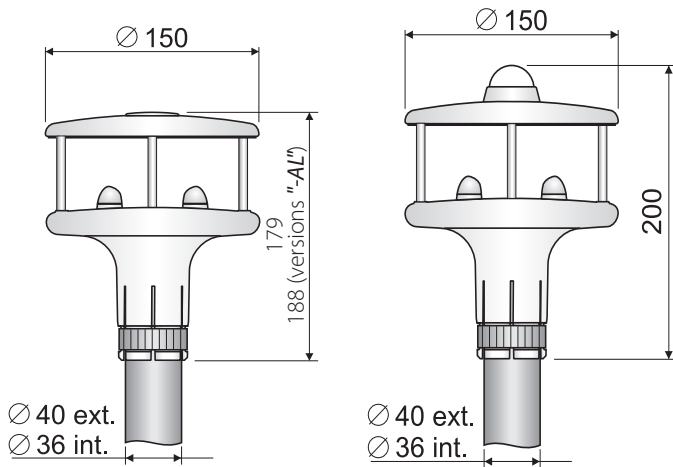

PC Application Software

The PC software HD52.3D-S allows configuring the instrument, viewing the real time measurements both graphically and numerically, managing graphical presentation, printing and export in Excel® format of the data acquired with the Monitor function.

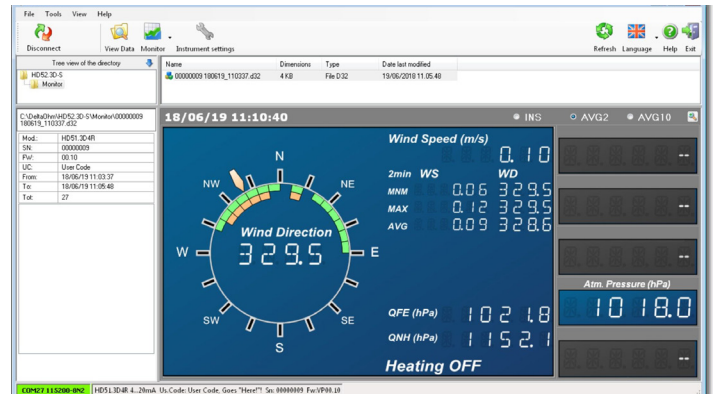

HD52.3D-S software: viewing the real time measurements

ISO 17025 - Air Velocity Laboratory

Our internal ISO 17025 accredited Air Velocity Laboratory is provided with two Göttinger-Type wind tunnels, in order to assure the best metrological performance (stability, uniformity). Each tunnel has a LDA (Laser Doppler anemometer) in order to assure the best reference standard available.

Air speed calibration ranges include low range wind tunnel operating in the range 0.15 m/s, 35 m/s with a circular test section of 320 mm and a high range 1 m/s, 60 m/s with a circular test section of 600 mm.

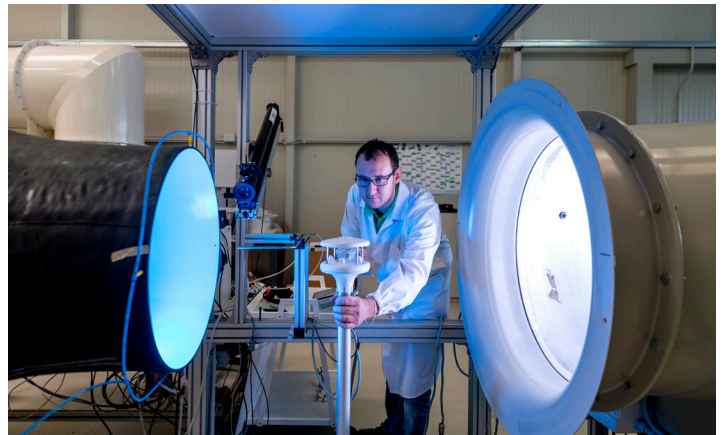

MODEL	WIND SPEED & WIND DIRECTION	ATMOSPHERIC PRESSURE	RELATIVE HUMIDITY + TEMPERATURE	GLOBAL SOLAR RADIATION	COMPASS + TILT ANGLES	HEATING
Models with housing in technopolymer						
HD51.3D [A][R]	✓				With option A in the code	With option R in the code
HD51.3D4[A][R]	✓	✓				
HD51.3DP[A][R]	✓			✓		
HD51.3DP4[A][R]	✓	✓		✓		
HD51.3D17[A][R]	✓		✓			
HD51.3D147[A][R]	✓	✓	✓			
HD51.3DP17[A][R]	✓		✓	✓		
HD51.3DP147[A][R]	✓	✓	✓	✓		
Models with housing in anodized aluminium alloy						
HD51.3D[A]R-AL	✓				With option A in the code	✓
HD51.3D4[A]R-AL	✓	✓				✓



Ordering Codes

HD51.3D

<p>Analog output Blank = 4...20 mA (default) V = 0...10 V V1 = 0...1 V V5 = 0...5 V</p>
<p>Heating Blank = without heating (default) R = with heating option</p>
<p>Compass + Tilt Angles Blank = without compass and tilt angles (default) A = with compass and tilt angles</p>
<p>Temperature Blank = without (default) 7 = with Temperature (<i>option 1 'RH' required</i>)</p>
<p>Atmospheric Pressure Blank = without (default) 4 = with atmospheric pressure option</p>
<p>Relative Humidity Blank = without (default) 1 = with Relative Humidity (<i>option 7 'Temperature' required</i>)</p>
<p>P = pyranometer K = bird spikes Blank = without pyranometer and/or bird spike</p>

Versions in technopolymer

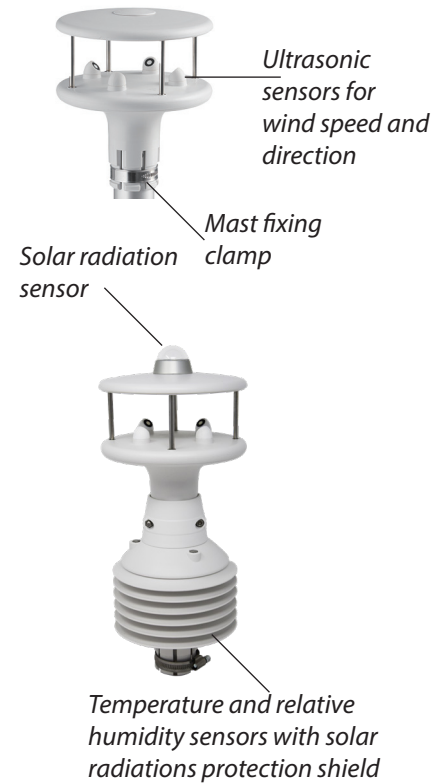

HD51.3D

<p>R</p>	<p>-AL</p>
<p>Analog output Blank = 4...20 mA (default) V = 0...10 V V1 = 0...1 V V5 = 0...5 V</p>	
<p>INTEGRATED HEATING</p>	
<p>Compass + Tilt Angles Blank = without compass and tilt angles (default) A = with compass and tilt angles</p>	
<p>Atmospheric Pressure Blank = without (default) 4 = with atmospheric pressure option</p>	
<p>Bird Dissuader Blank = without (default) K = with bird spikes</p>	

Accessories

RS52

Serial connection cable with built-in RS232/USB converter. USB connector for the PC and screw terminals on the instrument side. Useful for models measuring T and RH, which do not have the auxiliary RS485 serial output.

RS51K

Kit for connecting the anemometer RS485 auxiliary output to a PC (not for models measuring T and RH). It includes the SWD10 power supply and the RS485/USB adapter with screw terminals for the connection to the CP51... cable (not included), USB connector for the connection to the PC, jack connector for connecting the SWD10 power supply.

CP51.xx

Connecting cable with 19-pole M23 female connector on one side, open wires on the other side. Available lengths: 5 m, 10 m, 15 m, 20 m. For length over 20 m, contact our sales department.

CP52.C

Additional 19-pole M23 female free connector.

HD2005.20

Tripod with adjustable legs for installing environmental sensors. Material: anodized aluminum. Max. height 225 cm. It can be fixed on a flat base with screws or to the ground with pegs.

HD2005.20.1

Tripod with adjustable legs for installing environmental sensors. Material: anodized aluminum. Max. height 335 cm. It can be fixed on a flat base with screws or to the ground with pegs.



Version in anodized aluminium alloy