



HENNLICH

MERES

## 2-Axis Ultrasonic Anemometer HD53LS - series

2-axis ultrasonic static anemometer for measuring:

- Wind speed and direction, U-V Cartesian components of wind speed.
- Wind Gust (only in version with RS485 MODBUS-RTU output).

The average of wind speed and direction over a period configurable up to 10 minutes is calculated.

Two versions are available:

- **HD53LS.A:** with two analog outputs (one for wind speed and one for wind direction), factory configurable among 4...20 mA (standard), 0...1 V, 0...5 V, 0...10 V (**to be specified when ordering**).
- **HD53LS.S:** with RS485 MODBUS-RTU output.

Equipped with magnetic compass.

Installation on a  $\varnothing$  40 mm mast.

Supplied with PC software for configuring the instrument and viewing the real time measurements.

Optionally available, ILAC-MRA (ACCREDIA) traceable factory calibration.



### ADVANTAGES

- The absence of moving parts minimizes maintenance.
- High sensitivity for detecting very low speeds, which are not detectable by traditional methods.
- Fast and easy installation (on  $\varnothing$  40 mm mast, optional tripod available).
- The low power of the instrument allows installation in remote sites, with power from solar panel and battery.
- The version with RS485 MODBUS-RTU output allows instrument networking.

### TYPICAL APPLICATIONS

- Weather stations
- Environmental monitoring
- Agriculture
- Sports facility
- Marine and Harbour applications
- Airports
- HVAC
- Construction
- Renewable energy
- Building automation



HENNLICH  
MERES

## TECHNICAL SPECIFICATIONS

<b>Wind speed</b>	
Sensor type	Ultrasonic
Measuring Range	0...50 m/s
Resolution	0.01 m/s
Accuracy	± 0.2 m/s or ± 2%, the greatest (0...35 m/s) / ± 3% (> 35 m/s)
<b>Wind direction</b>	
Sensor type	Ultrasonic
Measuring Range	0...359.9°
Resolution	0.1°
Accuracy	± 2° RMSE from 1.0 m/s
<b>Compass</b>	
Sensor	Magnetic
Measuring range	0...360°
Resolution	0.1°
Accuracy	± 1°
<b>General features</b>	
Power supply	10...30 Vdc (15...30 Vdc for version with 0÷10 V analog output)
Power Consumption	26mA @ 12Vdc
Analog output	2 analog outputs: one for wind speed and one for wind direction ( <b>only in HD53LS.A</b> ). Analog output type is 4...20 mA as standard; 0...1 V, 0...5 V or 0...10 V available <b>on request</b> . Analog output refresh rate 1 Hz.
Digital output	RS485 MODBUS-RTU ( <b>only in HD53LS.S</b> )
Averaging interval	Configurable from 1 s to 10 min
Electrical connection	M23 connector
Operating temperature	-20...+55 °C
Survival speed	90 m/s
Dimensions	H=179mm, Ø=150mm
Weight	640 g approx.
Housing	ASA with metallic parts in AISI 316
Protection degree	IP66

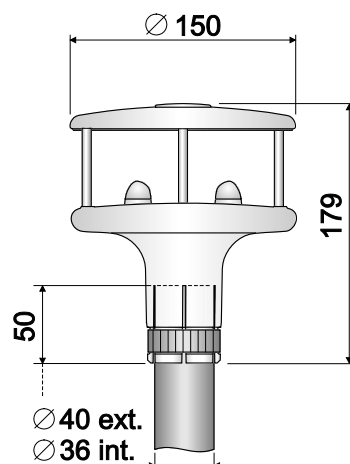

## ORDERING CODES

**HD53LS.A** 2-axis ultrasonic static anemometer. Equipped with compass. Analog output factory configurable among 4...20 mA (standard), 0...1 V, 0...5 V, 0...10 V (**to be specified when ordering**). Power supply: 10...30 Vdc (15...30 Vdc for 0...10 V analog output). Installation on a mast: external  $\varnothing$  40 mm, internal  $\varnothing$  36 mm. Input with M23 connector. It includes HD52.3DS software downloadable from Delta OHM website. Supplied with M23 movable connector. **On request CP52... cable.**

**HD53LS.S** 2-axis ultrasonic static anemometer. Equipped with compass. Digital RS485 MODBUS-RTU output. Power supply: 10...30 Vdc. Installation on a mast: external  $\varnothing$  40 mm, internal  $\varnothing$  36 mm. Input with M23 connector. It includes HD52.3DS software downloadable from Delta OHM website. Supplied with M23 movable connector. **On request CP52... cable.**

## ACCESSORIES

**RS52** Serial connection cable with built-in USB/RS232 converter. USB connector for the PC and screw terminals on the instrument side.

**CP52.5** Cable with 19-pole M23 connector on one end, open wires on the other end. Length 5 m.

**CP52.10** Cable with 19-pole M23 connector on one end, open wires on the other end. Length 10 m.

**CP52.15** Cable with 19-pole M23 connector on one end, open wires on the other end. Length 15 m.

**CP52.20** Cable with 19-pole M23 connector on one end, open wires on the other end. Length 20 m.

**CP52.30** Cable with 19-pole M23 connector on one end, open wires on the other end. Length 30 m.

**CP52.50** Cable with 19-pole M23 connector on one end, open wires on the other end. Length 50 m.

**CP52.75** Cable with 19-pole M23 connector on one end, open wires on the other end. Length 75 m.

**HD52.30K** Birds spikes.

**HD2005.20** Tripod with adjustable legs for installing environmental sensors. Material: anodized aluminum. Max. height 225 cm. It can be fixed on a flat base with screws or to the ground with pegs. Foldable legs for the transport.

**HD2005.20.1** Tripod with adjustable legs for installing environmental sensors. Material: anodized aluminum. Max. height 335 cm. It can be fixed on a flat base with screws or to the ground with pegs. Foldable legs for the transport.