

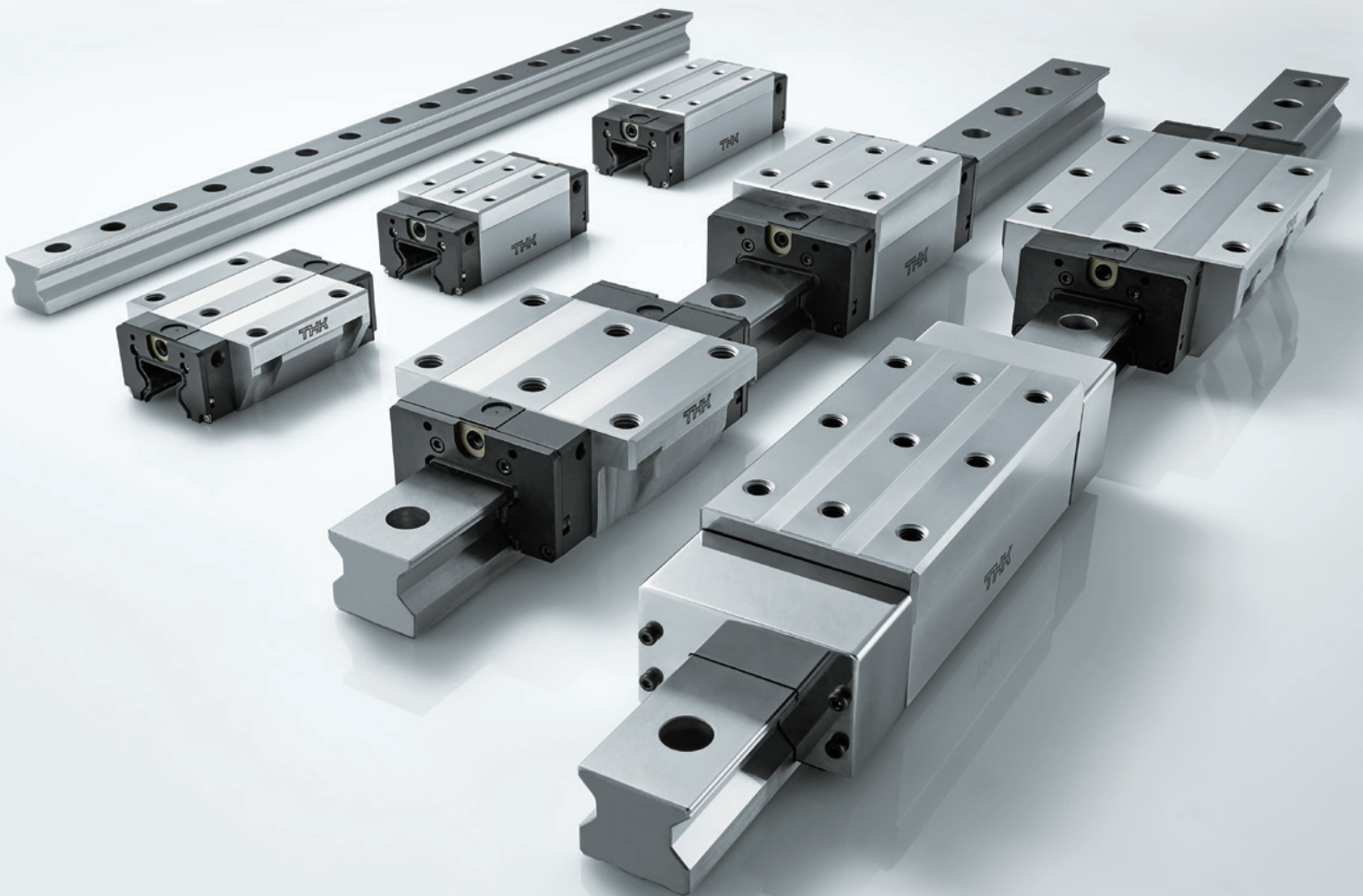

Caged Roller LM Guide

SRG



A roller guide with ultra-high rigidity and proven results



**HENNLICH -
ŽIJEME TECHNIKOU**

o.z. LIN-TECH HENNLICH s.r.o.
Českolipská 9, 412 01 Litoměřice

Telefon: +420 416 711 333
E-mail: lin-tech@hennlich.cz

www.hennlich.cz/lin-tech



A roller guide with ultra-high rigidity and high dust-proofing performance that makes it suitable to various special environments



Caged Roller LM Guide

SRG

Feature 1 Ultra-High Rigidity

Feature 2 Smooth, Stable Motion

Feature 3 Many Dust-Proofing Options Available

Feature 4 LM Blocks and LM Rails Available for Individual Sale

A roller guide with ultra-high rigidity and high performance that makes it suitable to various

Feature 1 Ultra-High Rigidity

Highly rigid rollers are used for the rolling elements, and the product's rigidity is further increased by making the length of the rollers be over 1.5 times their diameter.

High Rigidity Evaluation Data

(Preload) SRG: C0 radial clearance
Conventional: Radial clearance equivalent to C0

Radial rigidity

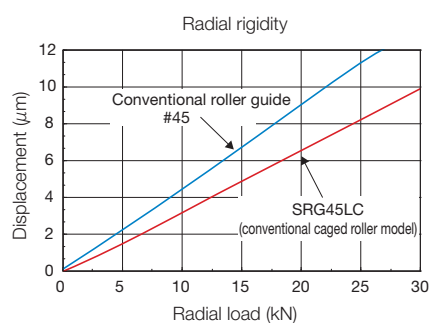
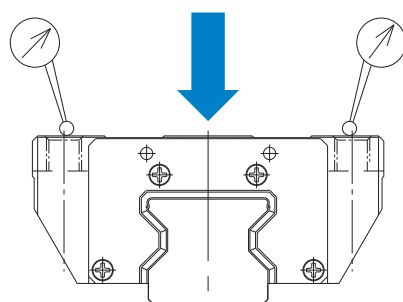

Reverse-radial rigidity

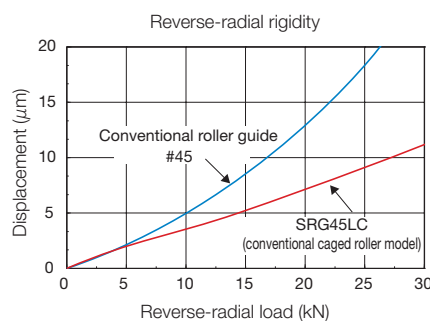
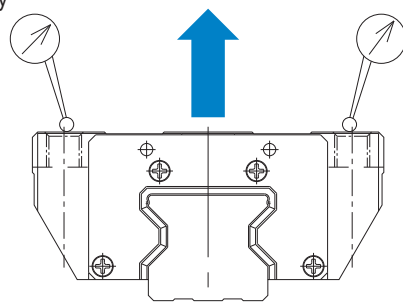

Horizontal rigidity

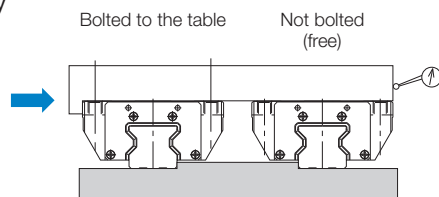

To avoid a moment being applied, two guides were used in parallel, and one was measured without being secured by bolts.

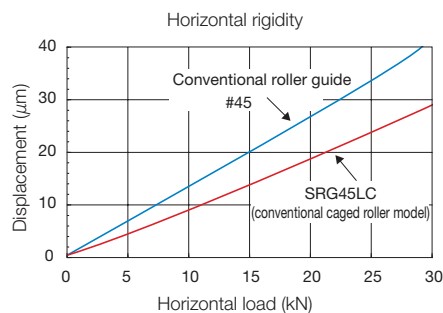

dust-proofing special environments

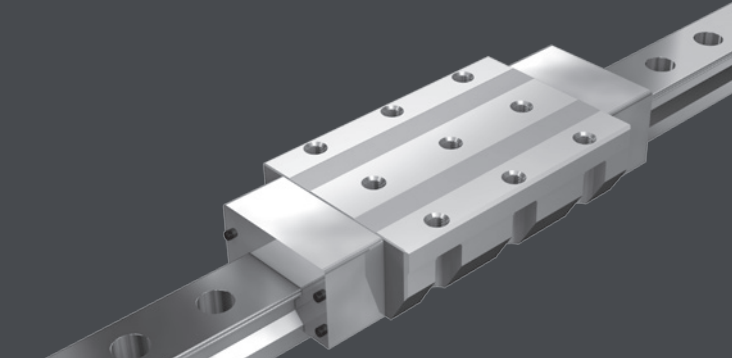

Feature 2 Smooth, Stable Motion

Evenly arranged rollers circulate in a way that limits the front-to-back and side-to-side movements of the rollers, preventing the rollers from skewing and minimizing rolling resistance fluctuations. The end result is smooth and stable motion.

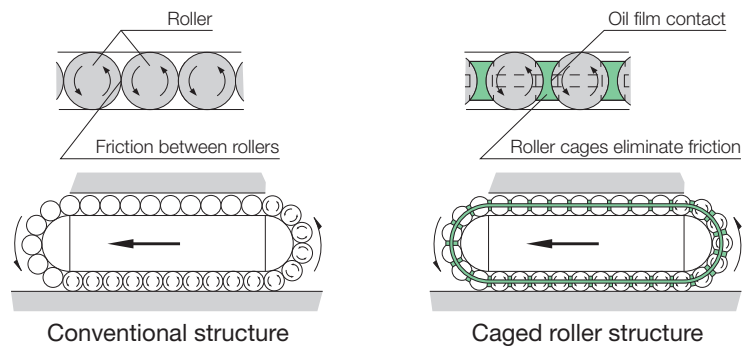

Measuring Rolling Resistance

(Conditions) Feed speed: 10 mm/s
Load: None (1 block)

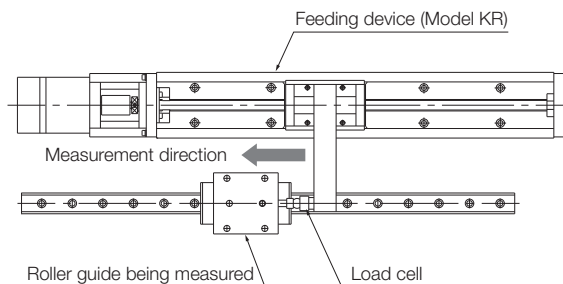

Rolling resistance measuring device

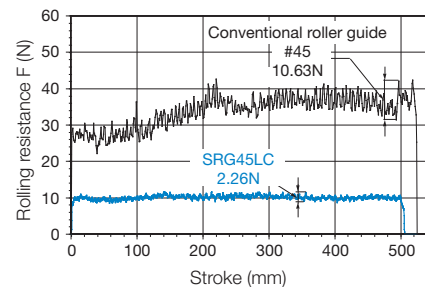

Rolling resistance fluctuation

Feature 3 Many Dust-Proofing Options Available

Various options, including end seals, inner seals, side seals, Laminated Contact Scraper LaCS, protectors, side scrapers, High Chemical Resistance Fluorine Seal FS, and plate covers, are available in order to accommodate various usage environments.

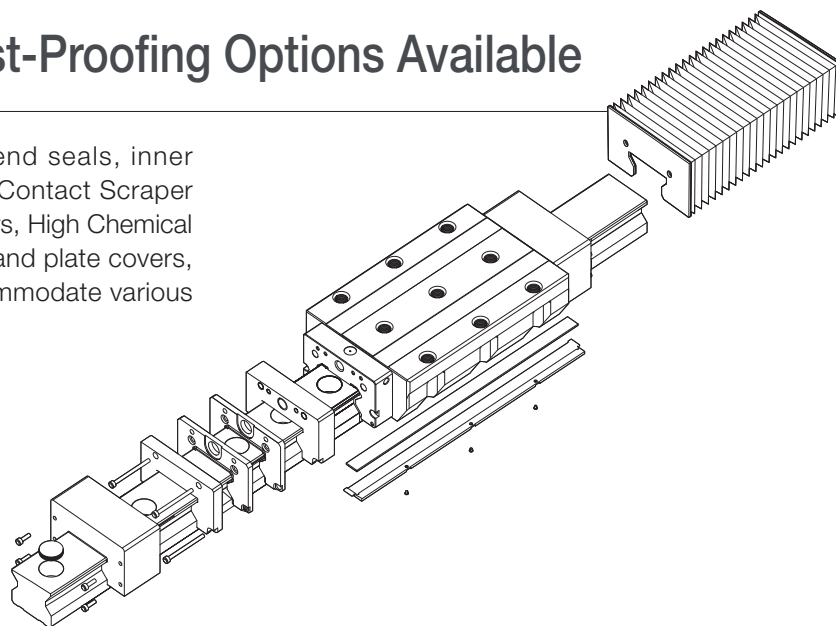

Structure

The SRG uses roller cages to achieve smooth motion with low friction, and it can run a long time with zero maintenance. In addition, rollers with optimized lengths and diameters have been utilized as the rolling elements in order to minimize elastic deformation and achieve ultra-high rigidity.

Also, each row of rollers is arranged at a 45° contact angle so the LM block will have an equal load rating in all directions: radial, reverse radial, and horizontal.

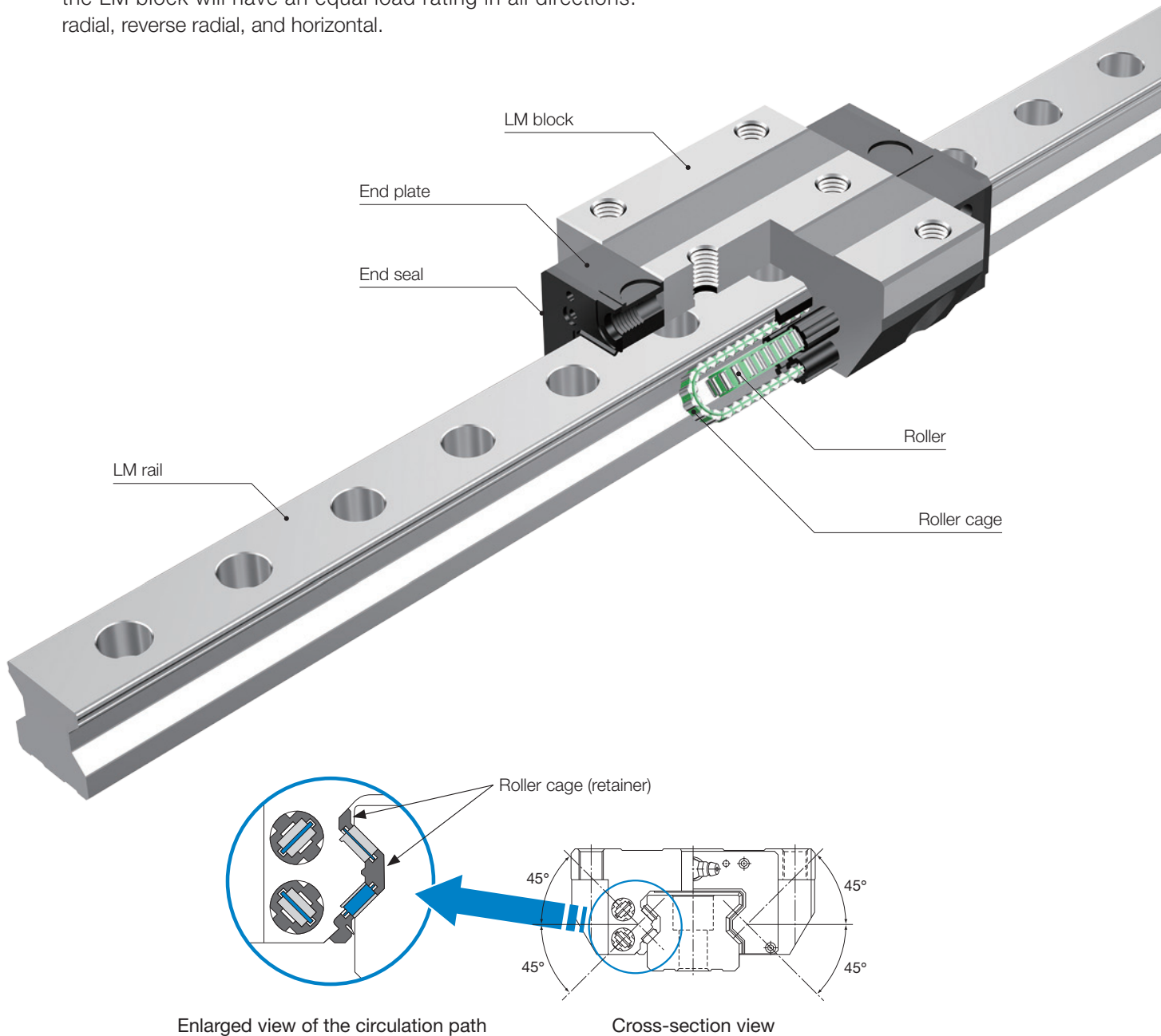

Lineup

This product comes in ten sizes ranging from 15 to 100, and a lineup of eleven block types is available: A/LA, C/LC/SLC, R/LR/SLR, and V/LV/SLV.

The Model SRG's dimensions conform to world-standard ISO specifications (ISO 12090-1:2011 Rolling Bearings).

Block type	SRG15X	SRG20X	SRG25X	SRG30X	SRG35	SRG45	SRG55	SRG65	SRG80	SRG100
Standard type	A	○	○	—	—	—	—	—	—	—
	C	—	—	○	○	○	○	○	—	—
	R	—	—	○	○	○	○	—	—	—
	V	○	○	—	—	—	—	○	—	—
Long type	LA	—	○	—	—	—	—	—	—	—
	LC	—	—	○	○	○	○	○	○	○
	LR	—	—	○	○	○	○	—	—	—
	LV	—	○	—	—	—	—	○	—	—
Super long type	SLC	—	—	—	—	○	○	○	—	—
	SLR	—	—	—	—	○	○	—	—	—
	SLV	—	—	—	—	—	—	○	—	—

○: Available, —: Not available

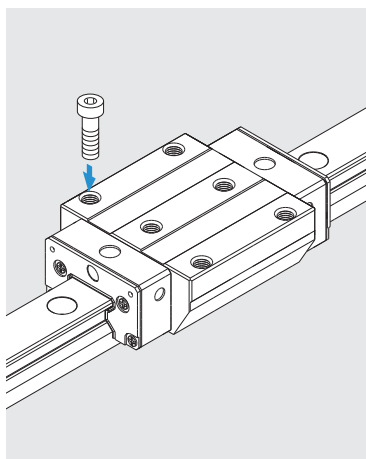

SRG-A/LA

The flanges of the LM block have tapped holes.

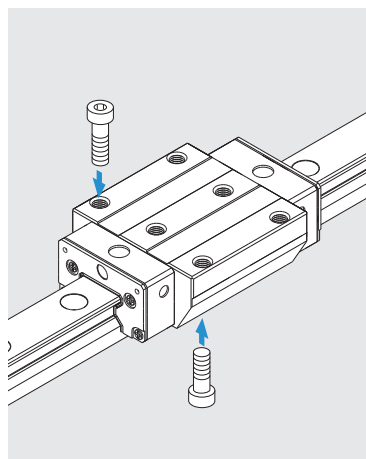

SRG-C/LC/SLC

This product has tapped holes. It can be mounted from the top or the bottom. It is used in places where the table cannot have through holes for mounting bolts.

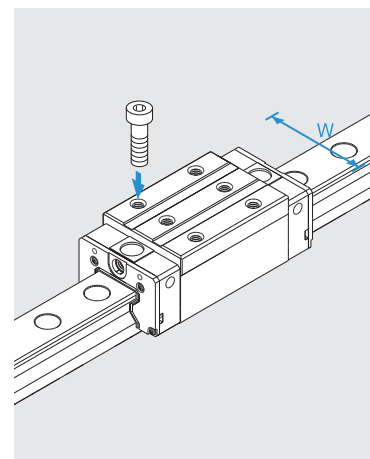

SRG-R/LR/SLR/V/LV/SLV

With this type, the LM block has a smaller width (W) and tapped holes. It is used in places where the space for the table width is limited.

Contamination Protection Accessories

It is necessary to prevent foreign materials from getting inside the product, as it will lead to abnormal wear and a shortened service life. If it is likely that foreign materials will get inside, it is important to select an effective sealing or contamination protection device suited to the environmental conditions.

Seals

End seals made of synthetic rubber that are highly resistant to wear and side seals that further improve dust-proofing effectiveness are available. Use the symbols in the table to the right to specify if you need a contamination protection accessory.

End Seal

Used in locations exposed to dust

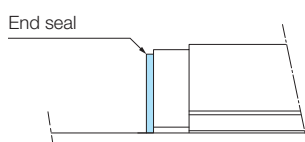

Inner Seal

Used in locations severely exposed to dust or cutting chips

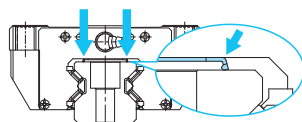

Double Seals

Used in locations exposed to excessive dust or cutting chips

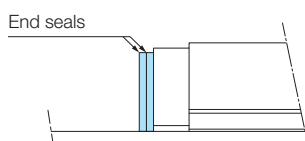

Metal Scraper (Non-Contact)

Used in locations where welding spatter may adhere to the LM rail

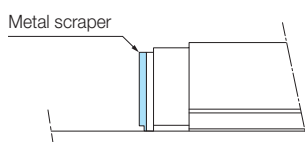

Option Compatibility

Symbol	Contamination protection accessories
UU	End seals
SS	End seals + side seals + inner seals
DD	Double seals + side seals + inner seals
ZZ	End seals + side seals + inner seals + metal scrapers
KK	Double seals + side seals + inner seals + metal scrapers

Side Seal

Used in locations where dust may enter the LM block from the side or bottom surfaces, such as vertical, horizontal, and inverted configurations

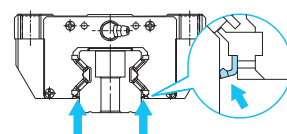

Seal Resistance Value

See the table for the maximum seal resistance of SS seals per LM block when the product is lubricated.

* For the overall lengths of LM blocks with seals attached, see p. 9.

Maximum Seal Resistance

Unit: N

Model	Seal symbol	Maximum seal resistance
SRG15X	SS	13
SRG20X		18
SRG25X		19
SRG30X		22
SRG35		30
SRG45		30
SRG55		34
SRG65		40
SRG85		47
SRG100		53

Laminated Contact Scraper LaCS

For locations with an adverse environment, Laminated Contact Scraper LaCS is available. LaCS removes minute foreign material adhering to the LM rail in multiple stages and prevents it from entering the LM block with a laminated contact structure (3-layer scraper).

Option Compatibility

Symbol	Contamination protection accessories
SSH	End seals + side seals + inner seals + LaCS
DDH	Double seals + side seals + inner seals + LaCS
ZZH	End seals + side seals + inner seals + LaCS + metal scrapers
KKH	Double seals + side seals + inner seals + LaCS + metal scrapers
JJH	End seals + side seals + inner seals + LaCS + protectors (which also function as metal scrapers)
TTH	Double seals + side seals + inner seals + LaCS + protectors (which also function as metal scrapers)
JJHHY	End seals + side seals + inner seals + LaCS + protectors (which also function as metal scrapers) + side scrapers
TTHHY	Double seals + side seals + inner seals + LaCS + protectors (which also function as metal scrapers) + side scrapers

Features

- Since the three layers of scrapers fully contact the LM rail, LaCS is highly capable of removing minute foreign material.
- Low friction resistance is achieved through the use of oil-impregnated, self-lubricating synthetic foam rubber.

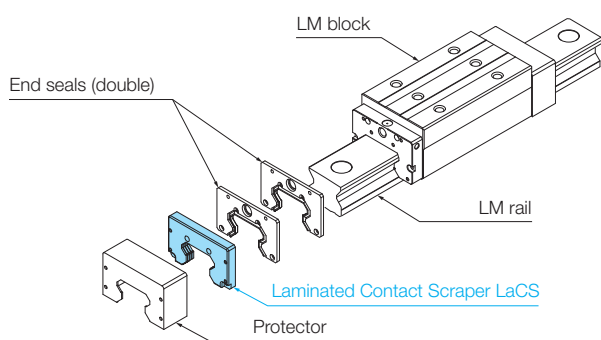

Exterior Drawing

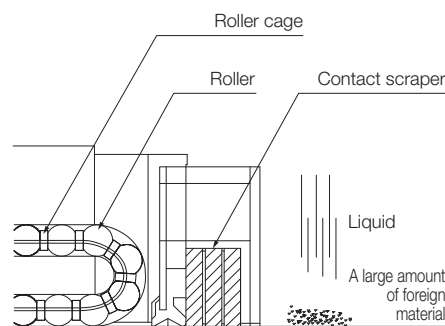

Structural Drawing

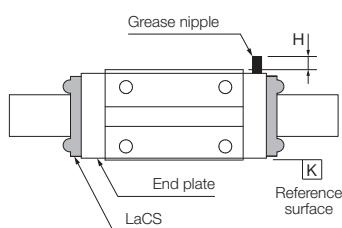

Location for Mounting the Side Grease Nipple

Dimensional Increase with a Grease Nipple

Model	Side greasing	
	H (mm)	Nipple type
SRG35C/LC/SLC	—	A-M6F
SRG35R/LR/SLR	7.2	
SRG45C/LC/SLC	—	
SRG45R/LR/SLR	7.2	
SRG55C/LC/SLC	—	
SRG55R/LR/SLR	7.2	
SRG65C/LC/SLC	—	
SRG65V/LV/SLV	6.2	

Note 1) Contact THK if you desire a grease nipple mounting location other than the above.

Note 2) The dimensional increase with a grease nipple will be the same whether using side scrapers with or without protectors.

Maximum Resistance Value when LaCS is Applied

Model	Maximum sliding resistance (N)
SRG20X	6.1
SRG25X	6.9
SRG30X	8.2
SRG35	9.1
SRG45	14.3
SRG55	18.2
SRG65	26

* This represents only the resistance of the LaCS and excludes resistance from the LM block and seals.

High Chemical Resistance Fluorine Seal FS

The fluorine seal is made of fluororubber and has excellent chemical resistance. The fluorine seal can be inserted from the upper surface of the LM rail and is easy to install.

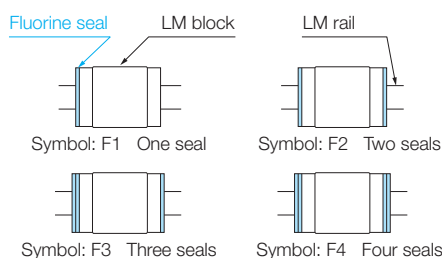

Standard Assemblies

Option Compatibility

Symbol	Contamination protection accessories
F2	Fluorine seals + side seals + inner seals
FZ2	Fluorine seals + side seals + inner seals + metal scrapers
FJ2	Fluorine seals + side seals + inner seals + protectors
F4	Fluorine seals (double) + side seals + inner seals
FZ4	Fluorine seals (double) + side seals + inner seals + metal scrapers
FJ4	Fluorine seals (double) + side seals + inner seals + protectors
QZF2	Fluorine seals + side seals + inner seals + QZ
QZFZ2	Fluorine seals + side seals + inner seals + metal scrapers + QZ
QZFF2	Fluorine seals + side seals + inner seals + QZ + protectors
QZF4	Fluorine seals (double) + side seals + inner seals + QZ
QZFZ4	Fluorine seals (double) + side seals + inner seals + metal scrapers + QZ
QZFF4	Fluorine seals (double) + side seals + inner seals + QZ + protectors

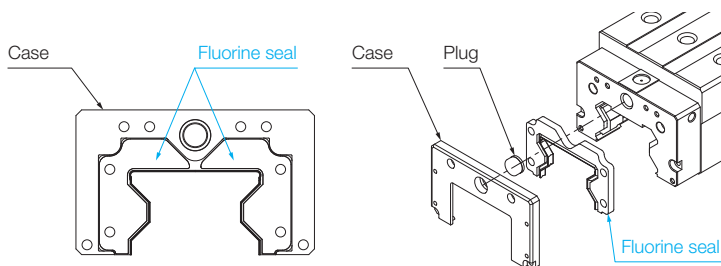

Components/Structure

Maximum Seal Resistance of FS Unit: N

Model	Seal symbol	Maximum seal resistance
SRG35	F2	30
SRG45		30
SRG55		34
SRG65		40

Note) This is the sliding resistance of two fluorine seals and one inner seal on one LM block and excludes the sliding resistance of the block.

Overall Block Length with Fluorine Seals and Other Accessories Attached

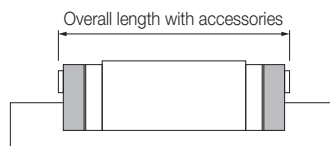

Unit: mm

Model	F2	F4	FZ2	FZ4	FJ2	FJ4	QZF2	QZF4	QZFF2	QZFF4	QZFFJ2	QZFFJ4
	Fluorine seals	Fluorine seals (double)	Fluorine seals + Metal scrapers	Fluorine seals (double) + Metal scrapers	Fluorine seals + Protectors	Fluorine seals (double) + Protectors	QZ + Fluorine seals	QZ + Fluorine seals (double)	QZ + Fluorine seals + Metal scrapers	QZ + Fluorine seals (double) + Metal scrapers	QZ + Fluorine seals + Protectors	QZ + Fluorine seals (double) + Protectors
SRG35C/R	129	140.8	137.4	149.2	137.4	149.2	159	170.8	167.4	179.2	167.4	179.2
SRG35LC/LR	159	170.8	167.4	179.2	167.4	179.2	189	200.8	197.4	209.2	197.4	209.2
SRG35SLC/SLR	184.8	196.6	193.2	205	193.2	205	214.8	226.6	223.2	235	223.2	235
SRG45C/R	159	172.2	168.2	181.4	168	181.2	189	202.2	198.2	211.4	198	211.2
SRG45LC/LR	194	207.2	203.2	216.4	203	216.2	224	237.2	233.2	246.4	233	246.2
SRG45SLC/SLR	235.5	248.7	244.7	257.9	244.5	257.7	265.5	278.7	274.7	287.9	274.5	287.7
SRG55C/R	189	202.2	198.2	211.4	198	211.2	229	242.2	238.2	251.4	238	251.2
SRG55LC/LR	239	252.2	248.2	261.4	248	261.2	279	292.2	288.2	301.4	288	301.2
SRG55SLC/SLR	296	309.2	305.2	318.4	305	318.2	336	349.2	345.2	358.4	345	358.2
SRG65C/V	249.3	264.9	260.5	276.1	260.3	275.9	289.3	304.9	300.5	316.1	300.3	315.9
SRG65LC/LV	307.4	323	318.6	334.2	318.4	334	347.4	363	358.6	374.2	358.4	374
SRG65SLC/SLV	384.4	400	395.6	411.2	395.4	411	424.4	440	435.6	451.2	435.4	451

Protectors

Protectors minimize the ingress of foreign material even in harsh environments where foreign material such as fine particles and liquids are present.

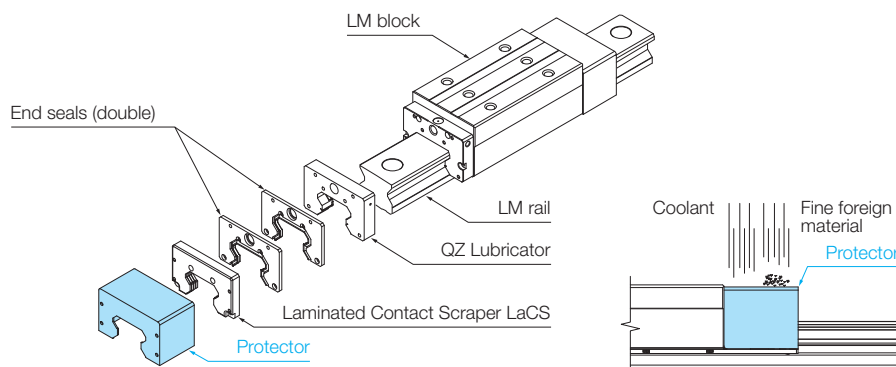

Exterior Drawing

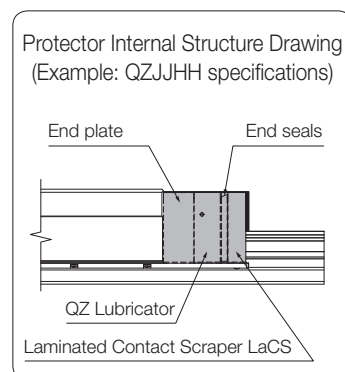

Overall LM Block Length with Seals Attached

Unit: mm

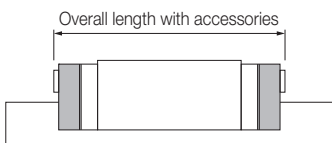

Model	UU	SS	DD	ZZ	KK	SSHH	DDHH	ZZHH	KKHH	JJHH	TTHH
SRG15X A/V	69.2	69.2	71.2	—	—	—	—	—	—	—	—
SRG20X A/V	86.2	86.2	88.2	89.6	91.6	105.2	107.2	107.6	109.6	—	—
SRG20X LA/LV	106.2	106.2	108.2	109.6	111.6	125.2	127.2	127.6	129.6	—	—
SRG25X C/R	95.1	95.1	100.1	100.1	105.1	114.9	119.9	117.3	122.3	—	—
SRG25X LC/LR	115.1	115.1	120.1	120.1	125.1	134.9	139.9	137.3	142.3	—	—
SRG30X C/R	111	111	118	116	123	130.8	137.8	133.2	140.2	136.4	143.4
SRG30X LC/LR	135	135	142	140	147	154.8	161.8	157.2	164.2	160.4	167.4
SRG35C/R	125	125	132.8	130.7	138.5	142.6	150.4	151	158.8	150.8	158.6
SRG35LC/LR	155	155	162.8	160.7	168.5	172.6	180.4	181	188.8	180.8	188.6
SRG35SLC/SLR	180.8	180.8	188.6	186.5	194.3	198.4	206.2	206.8	214.6	206.6	214.4
SRG45C/R	155	155	164.2	161.5	170.7	175.6	184.8	184.8	194	184.6	193.8
SRG45LC/LR	190	190	199.2	196.5	205.7	210.6	219.8	219.8	229	219.6	228.8
SRG45SLC/SLR	231.5	231.5	240.7	238	247.2	252.1	261.3	261.3	270.5	261.1	270.3
SRG55C/R	185	185	194.2	191.5	200.7	205.6	214.8	214.8	224	214.6	223.8
SRG55LC/LR	235	235	244.2	241.5	250.7	255.6	264.8	264.8	274	264.6	273.8
SRG55SLC/SLR	292	292	301.2	298.5	307.7	312.6	321.8	321.8	331	321.6	330.8
SRG65C/V	244.9	244.9	256.1	252.5	263.7	268.9	280.1	280.1	291.3	279.9	291.1
SRG65LC/LV	303	303	314.2	310.6	321.8	327	338.2	338.2	349.4	338	349.2
SRG65SLC/SLV	380	380	391.2	387.6	398.8	404	415.2	415.2	426.4	415	426.2
SRG85LC	350	350	361.2	361	372.2	—	—	—	—	—	—
SRG100LC	395	395	406.2	411	422.2	—	—	—	—	—	—

Note) The overall length of the LM block is the same for YY specifications (with side scrapers).

Side Scrapers

Features

- Side scrapers minimize foreign material entering from the side of the LM Guide in a harsh environment.
- Effective at dust protection when the system is inverted or mounted on a wall.

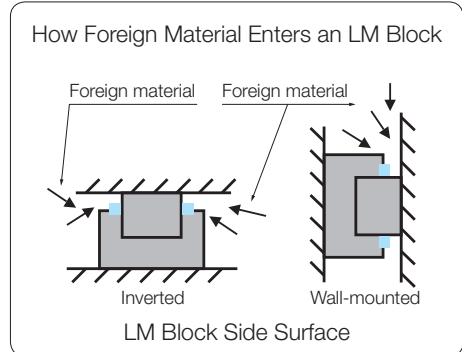
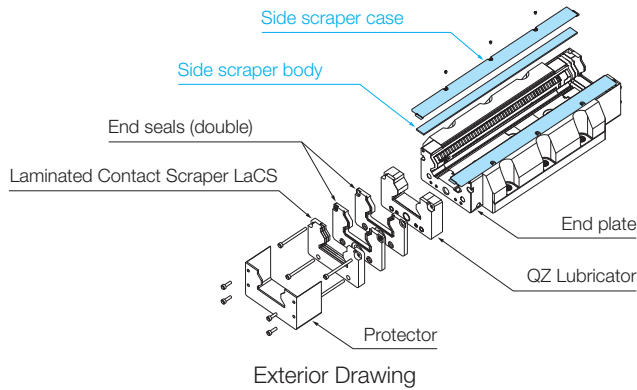

Note) Side scrapers are not available for individual sale.

Plate Cover

A plate cover can be placed over the entire upper surface of the LM rail to better prevent foreign materials from getting inside the LM block. Special tools that suit the installation method for the plate cover are available.

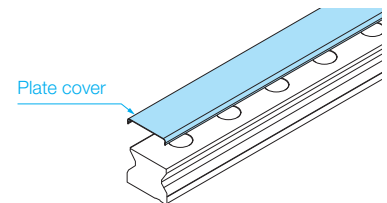

Plate Cover Installation Tool

A plate cover installation tool and removing/mounting jig are available to make the plate cover installation process easier. Contact THK for details.

Note 1) Please order the plate cover installation tool separately.
Note 2) Each tool can be used for more than one size (see the table).

Plate Cover Installation Tool Compatibility

Model	Model
SRG25X, SRG30X, SRG35	WPC-AT25/30/35
SRG45, SRG55, SRG65	WPC-AT45/55/65

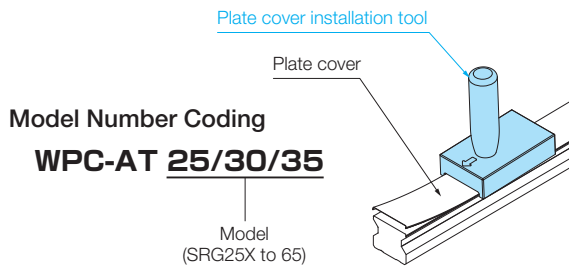

Cover Stamper

A jig is available to slide the plate cover on and install while the LM block is mounted on the LM rail. Contact THK for details.

Note) Please order the cover stamper separately.

Cover Stamper Compatibility

LM Guide model	Cover stamper model	LM Guide model	Cover stamper model
SRG25X	WPC-ST25	SRG45	WPC-ST45
SRG30X	WPC-ST30	SRG55	WPC-ST55
SRG35	WPC-ST35	SRG65	WPC-ST65

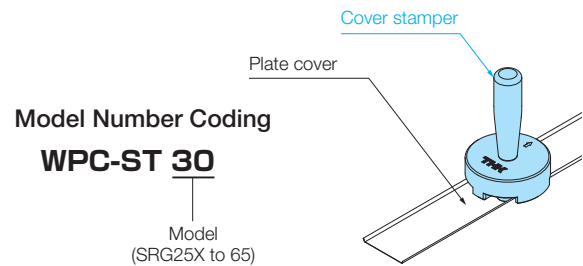

Plate Cover Roll

An extra-long plate cover is available for you to store on-site and use for maintenance and replacements when necessary.

Note) Please order protective caps separately.

Plate cover roll introduction and installation guide (video)



<https://www.thk.com/video/wpc/en>

Model Number Coding

WPC25 - 90M

Model (SRG25X to 65) Length (90 m)

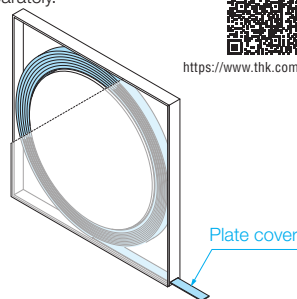

Protective Caps

Protective caps are included when a product is ordered with a plate cover. Using the protective caps will prevent injuries caused by coming in contact with the end of the plate cover.

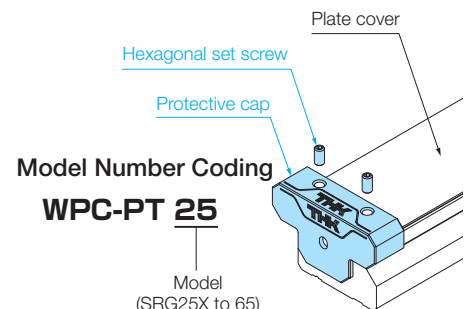

■ Dedicated Cap for LM Rail Mounting Holes

Using dedicated caps to cover the LM rail mounting holes helps prevent foreign material from entering the mounting holes and LM block.

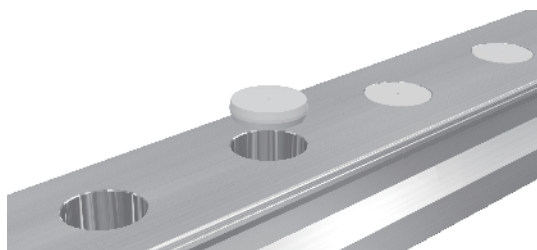

Option Compatibility

Model	C cap	CV cap	GC cap
SRG15X	○	—	—
SRG20X	—	○	○
SRG25X	—	○	○
SRG30X	—	○	○
SRG35	—	○	○
SRG45	—	○	○
SRG55	—	○	○
SRG65	—	○	○
SRG85	○	—	○
SRG100	○	—	○

○: Available, —: Not available

CV Caps/C Caps

The caps are made of a special synthetic resin. The CV cap is the successor to the C cap, and its new structure makes it easier to insert.

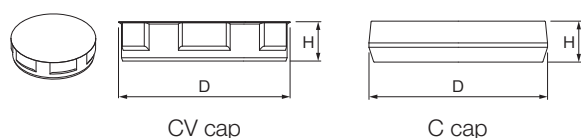

Model	Cap model	Bolts used	Main dimensions (mm)	
			D	H
SRG15X	C4	M4	7.9	1
SRG20X	CV5	M5	9.8	2.6
SRG25X	CV6	M6	11.4	2.6
SRG30X SRG35	CV8	M8	14.4	3.3
SRG45	CV12	M12	20.4	3.4
SRG55	CV14	M14	23.4	5.5
SRG65	CV16	M16	26.4	5.6
SRG85	C22	M22	35.5	5.7
SRG100	C24	M24	39.5	7.7

GC Caps

GC caps are made of metal. (They are RoHS compliant.) GC caps adhere closer to the counterbore than CV caps and C caps, so there is no clearance once they are inserted.

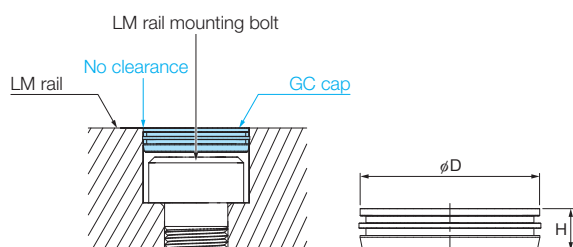

Model	Cap model	Bolts used	Main dimensions (mm)	
			D	H
SRG20X	GC5	M5	9.86	2.5
SRG25X	GC6	M6	11.36	2.5
SRG30X SRG35	GC8	M8	14.36	3.5
SRG45	GC12	M12	20.36	4.6
SRG55	GC14	M14	23.36	5
SRG65	GC16	M16	26.36	5
SRG85	GC22	M22	35.36	5
SRG100	GC24	M24	39.36	5

Note 1) GC caps are only sold with an LM Guide. They are not sold separately. The LM Guide model number code will have "GC" at the end when it is delivered.

Model Number Coding

SRG45 LC 2 UU CO + 1200L P GC

GC caps attached

Note 2) GC caps cannot be used with LM rails that have undergone surface treatment.

Note 3) LM rail mounting holes for GC caps are special. (The mouth is not chamfered.)

Note 4) Be careful not to injure your hand when inserting GC caps.

Note 5) Be sure to make the GC caps level with the upper surface of the LM rail and clean (wipe) that surface after insertion.

Note 6) Contact THK if this product will be used in special environments such as in a vacuum, or at very low or high temperatures.

■ Dedicated Bellows JSRG for Model SRG

Used in locations exposed to excessive dust or cutting chips.

The dimensions for the JSRG dedicated bellows for the Model SRG are given below. Please specify one of the following models.

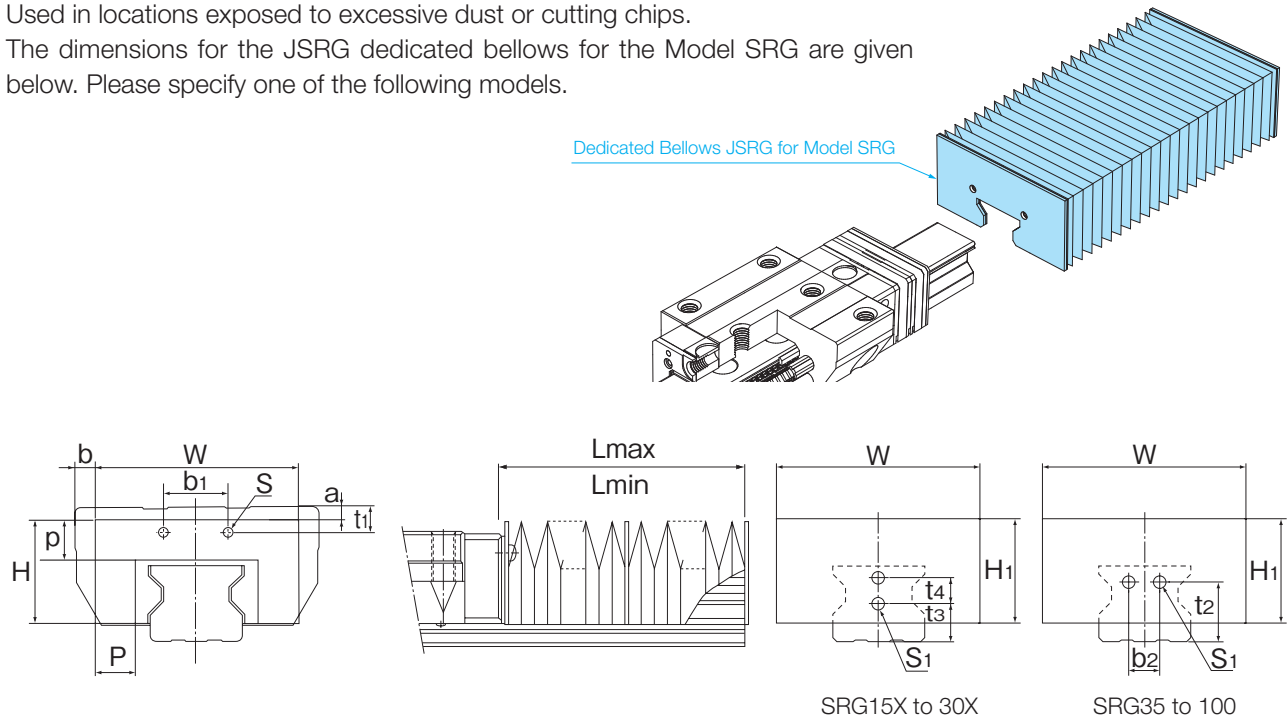

Unit: mm

Model	Main dimensions																		A ($\frac{L_{max}}{L_{min}}$)	Applicable model		
	W	H	H ₁	P	p	b ₁	t ₁		b ₂	t ₂	t ₃	t ₄	Screw size S	Mounting bolt S ₁	a		b					
							A/C type	R/V type							A/C type	R/V type	A/C type	R/V type				
JSRG	15	55	27	27	14.2	12.7	28	10.3	10.3	—	—	10.6	—	M2	M4	-7	-7	4	10.5	5	SRG	15X
	20	66	32	32	17	15	38.5	9.6	9.6	—	—	7.4	8	M2	M3	-6.6	-6.6	1.5	11	6		20X
	25	78	38	38	23	18	27.6	3.9	7.9	—	—	10	8	M2	M3×6ℓ	-6.5	-2.5	4	15	6		25X
	30	84	42	42	22	19	37.4	10.4	13.4	—	—	11	10	M3	M4×8ℓ	-5	-2	3	12	7		30X
	35	88	42	42	22	15	35	5	12	13	23	—	—	M3	M4×4ℓ	0	7	6	-9	5		35
	45	100	51	51	20	20	32	7	17	15	29	—	—	M3	M5×4ℓ	0	10	10	-7	7		45
	55	108	57	57	20	20	36	10	20	25	35	—	—	M3	M5×4ℓ	3	13	16	-4	7		55
	65	132	75.5	75.5	28.5	25	46	9	9	28	42	—	—	M4	M6×5ℓ	3	3	19	-3	9		65
	85	168	91	91	35.5	30	120	15	—	30	55	—	—	M6	M6×8ℓ	3	—	23.5	—	9		85
100	198	100	100	43	33	152	13.3	—	36	60	—	—	M6	M6×8ℓ	4	—	26	—	9	100		

Note 1) Please contact THK if you will be using the dedicated bellows in anything other than a horizontal orientation (i.e. vertical, wall-mounted, or inverted), or if you require heat-resistant specifications.

Note 2) Products with bellows can be greased through the use of a side nipple.

Note 3) When using the dedicated bellows, machining will be required to mount it on the LM block and LM rail. Please specify this when ordering.

Note 4) When using oil lubrication, be sure to let THK know the mounting orientation and the position where the pipe fitting will be attached to each LM block.

Model Number Coding

JSRG35 - 60/420

Model
Bellows for SRG35

Bellows dimensions
(Bellows length when contracted/extended)

Note) The bellows length is calculated as follows.

$$L_{min} = \frac{S}{(A-1)} \quad S: \text{Stroke length (mm)}$$

$$L_{max} = L_{min} \cdot A \quad A: \text{Extension rate}$$

Lubrication

Standard Grease

AFB-LF Grease is a general-purpose grease that provides excellent extreme pressure and mechanical stability properties through the use of a refined mineral oil base oil and a lithium-based consistency enhancer.

* Non-standard greases are also available. Contact THK for details.

AFB-LF Representative Physical Properties

Item	Representative property	Testing method
Consistency enhancer	Lithium-based	
Base oil	Refined mineral oil	
Base oil kinematic viscosity: mm ² /s (40°C)	170	JIS K 2220 23
Worked penetration (25°C, 60 W)	275	JIS K 2220 7
Mixing stability (100,000 W)	345	JIS K 2220 15
Dropping point: °C	193	JIS K 2220 8
Evaporation volume: mass% (99°C, 22 h)	0.4	JIS K 2220 10
Oil separation rate: mass% (100°C, 24 h)	0.6	JIS K 2220 11
Copper plate corrosion (B method, 100°C, 24 h)	Passed	JIS K 2220 9
Low-temperature torque: mN·m (-20°C)	Starting	JIS K 2220 18
	Rotational	
4-ball testing (welding load): N	3089	ASTM D2596
Operating temperature range: °C	-15 to 100	
Color	Yellowish brown	

QZ Lubricator

The QZ Lubricator feeds the right amount of lubricant to the LM rail raceway. This allows an oil film to be constantly formed between the rollers and the raceway and significantly extends the lubrication maintenance interval. The QZ Lubricator is made primarily of three components: (1) a highly oil-impregnated fiber net (which stores lubricant), (2) a high-density fiber net (which applies the lubricant to the raceways), and (3) an oil control plate (which adjusts the amount of oil being applied). The lubricant is supplied from within the QZ Lubricator using the basic principle of capillary action, as used in felt-tip pens.

Option Compatibility

Symbol	Contamination protection accessories
QZUU	End seals + QZ
QZSS	End seals + side seals + inner seals + QZ
QZDD	Double seals + side seals + inner seals + QZ
QZZZ	End seals + side seals + inner seals + metal scrapers + QZ
QZKK	Double seals + side seals + inner seals + metal scrapers + QZ
QZSSH	End seals + side seals + inner seals + LaCS + QZ
QZDDH	Double seals + side seals + inner seals + LaCS + QZ
QZZZH	End seals + side seals + inner seals + metal scrapers + LaCS + QZ
QZKHH	Double seals + side seals + inner seals + metal scrapers + LaCS + QZ
QZJJH	End seals + side seals + inner seals + LaCS + protectors (which also function as metal scrapers) + QZ
QZTTH	Double seals + side seals + inner seals + LaCS + protectors (which also function as metal scrapers) + QZ
QZJJHYY	End seals + side seals + inner seals + LaCS + protectors (which also function as metal scrapers) + side scrapers + QZ
QZTTHYY	Double seals + side seals + inner seals + LaCS + protectors (which also function as metal scrapers) + side scrapers + QZ

Features

- Since it compensates for oil loss, the lubrication maintenance interval can be significantly extended.
- It is an eco-friendly lubrication system that does not contaminate the surrounding area, as it feeds the right amount of lubricant to the roller raceway.

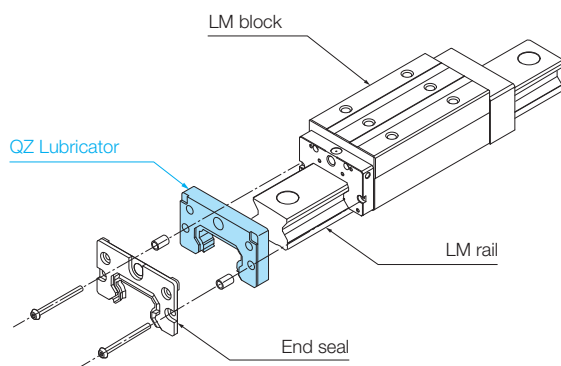

Exterior Drawing

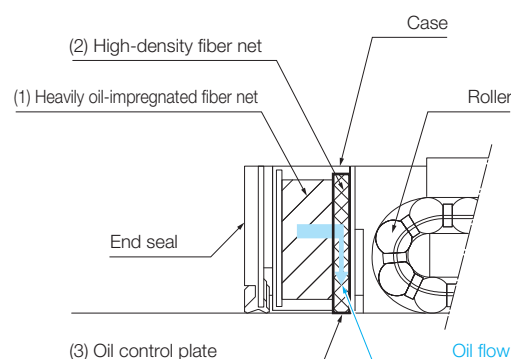

Structural Drawing

Overall LM Block Length Dimension with QZ Lubricator Attached

Unit: mm

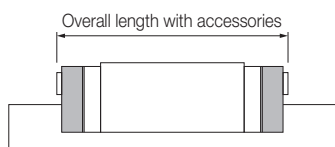

Model	QZUU	QZSS	QZDD	QZZZ	QZKK	QZSSH	QZDDH	QZZZH	QZKKH	QZJHH	QZTHH
SRG15X A/V	90.6	90.6	92.6	—	—	—	—	—	—	—	—
SRG20X A/V	107.6	107.6	109.6	111	113	125.2	127.2	127.6	129.6	—	—
SRG20X LA/LV	127.6	127.6	129.6	131	133	145.2	147.2	147.6	149.6	—	—
SRG25X C/R	125.1	125.1	130.1	130.1	135.1	144.9	151.3	147.3	153.7	—	—
SRG25X LC/LR	145.1	145.1	150.1	150.1	155.1	164.9	171.3	167.3	173.7	—	—
SRG30X C/R	141	141	148	146	153	160.8	169.2	164.6	171.6	166.4	174.8
SRG30X LC/LR	165	165	172	170	177	184.8	193.2	188.6	195.6	190.4	198.8
SRG35C/R	155	155	162.8	163.4	171.2	172.6	180.4	181	188.8	180.8	188.6
SRG35LC/LR	185	185	192.8	193.4	201.2	202.6	210.4	211	218.8	210.8	218.6
SRG35SLC/SLR	210.8	210.8	218.6	219.2	227	228.4	236.2	236.8	244.6	236.6	244.4
SRG45C/R	185	185	194.2	194.2	203.4	205.6	214.8	214.8	224	214.6	223.8
SRG45LC/LR	220	220	229.2	229.2	238.4	240.6	249.8	249.8	259	249.6	258.8
SRG45SLC/SLR	261.5	261.5	270.7	270.7	279.9	282.1	291.3	291.3	300.5	291.1	300.3
SRG55C/R	225	225	234.2	234.2	243.4	245.6	254.8	254.8	264	254.6	263.8
SRG55LC/LR	275	275	284.2	284.2	293.4	295.6	304.8	304.8	314	304.6	313.8
SRG55SLC/SLR	332	332	341.2	341.2	350.4	352.6	361.8	361.8	371	361.6	370.8
SRG65C/V	284.9	284.9	296.1	296.1	307.3	308.9	320.1	320.1	331.3	319.9	331.1
SRG65LC/LV	343	343	354.2	354.2	365.4	367	378.2	378.2	389.4	378	389.2
SRG65LC/SLV	420	420	431.2	431.2	442.4	444	455.2	455.2	466.4	455	466.2

Note) The overall length of the LM block is the same for YY specifications (with side scrapers).

■ Greasing Holes

The LM block can be greased from the side or top surface. In order to prevent foreign material from entering the LM block, greasing holes are not through holes in blocks with regular specifications. Contact THK if these will be used. In addition, contact THK if you will use an upper surface greasing hole with a Model SRG-R, SRG-LR, or SRG-SLR, as a lubrication adapter is required.

The lubricant may not reach the raceway if the LM Guide is not installed in a horizontal orientation.

Be sure to let THK know the mounting orientation and the position where the grease nipple or pipe fitting will be attached to each LM block.

Unit: mm

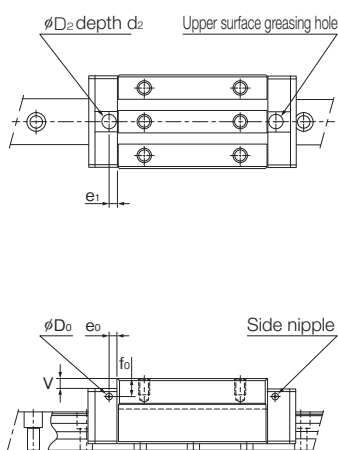

Model	Pilot hole for side nipple			Applicable nipple	Upper surface greasing hole				
	e ₀	f ₀	D ₀		D ₂	(O-ring)	V	e ₁	d ₂
SRG15XA	4	6	2.9	PB107	9.2	(P6)	0.4	5.5	1.4
SRG15XV									
SRG20XA	4	6	2.9	PB107	9.2	(P6)	0.4	6.5	1.4
SRG20XLA									
SRG20XV	4	6	2.9	PB107	9.2	(P6)	0.4	6.5	1.4
SRG20XLV									
SRG25XC	6	7.3	5.2	M6F	10.2	(P7)	0.4	6	1.4
SRG25XLC									
SRG25XR	6	11.3	5.2	M6F	10.2	(P7)	4.5	6	1.4
SRG25XLR									
SRG30XC	6	7.5	5.2	M6F	10.2	(P7)	0.4	6	1.4
SRG30XLC									
SRG30XR	6	10.5	5.2	M6F	10.2	(P7)	3.4	6	1.4
SRG30XLR									
SRG35C	6	6	5.2	M6F	10.2	(P7)	0.4	6	1.4
SRG35LC									
SRG35SLC	6	13	5.2	M6F	10.2	(P7)	7.4	6	1.4
SRG35R									
SRG35LR	6	13	5.2	M6F	10.2	(P7)	7.4	6	1.4
SRG35SLR									
SRG45C	7	7	5.2	M6F	10.2	(P7)	0.4	7	1.4
SRG45LC									
SRG45SLC	7	17	5.2	M6F	10.2	(P7)	10.4	7	1.4
SRG45R									
SRG45LR	7	17	5.2	M6F	10.2	(P7)	10.4	7	1.4
SRG45SLR									
SRG55C	9	8.5	5.2	M6F	10.2	(P7)	0.4	11	1.4
SRG55LC									
SRG55SLC	9	18.5	5.2	M6F	10.2	(P7)	10.4	11	1.4
SRG55R									
SRG55LR	9	18.5	5.2	M6F	10.2	(P7)	10.4	11	1.4
SRG55SLR									
SRG65C	9	13.5	5.2	M6F	10.2	(P7)	0.4	10	1.4
SRG65LC									
SRG65SLC	9	13.5	5.2	M6F	10.2	(P7)	0.4	10	1.4
SRG65V									
SRG65LV	9	13.5	5.2	M6F	10.2	(P7)	0.4	10	1.4
SRG65SLV									
SRG85LC	15	22	8.2	PT1/8	13	(P10)	0.4	10	1.4
SRG100LC	15	23	8.2	PT1/8	13	(P10)	0.4	10	1.4

Note 1) The effect of the roller cage results in a longer lubrication interval than the full-roller type, but the interval will vary if it bears a heavy load or moves at high speeds. Contact THK if the product will be used in such an environment.

Note 2) Upper surface lubrication is for oil lubrication only. Contact THK if you are considering using the greasing hole on the top face for grease lubrication.

Radial Clearance Specifications

The radial clearance significantly affects the running accuracy, load resistance, and rigidity. Therefore, it is necessary to select a clearance that is appropriate for the application. An appropriate radial clearance will prevent vibrations and impacts from occurring when the device is running, as well as improve the service life and accuracy of the LM Guide. The Model SRG has three types of radial clearance (preload): normal, light preload, and medium preload.

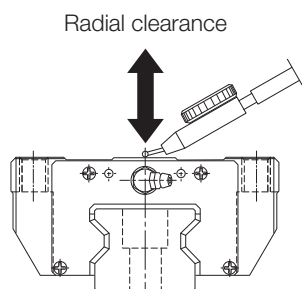

Radial Clearance Specifications

Unit: μm

Model	Normal	Light preload	Medium preload
	No symbol	C1	C0
15X	-0.5 to 0	-1 to -0.5	-2 to -1
20X	-0.8 to 0	-2 to -0.8	-3 to -2
25X	-2 to -1	-3 to -2	-4 to -3
30X	-2 to -1	-3 to -2	-4 to -3
35	-2 to -1	-3 to -2	-5 to -3
45	-2 to -1	-3 to -2	-5 to -3
55	-2 to -1	-4 to -2	-6 to -4
65	-3 to -1	-5 to -3	-8 to -5
85	-3 to -1	-7 to -3	-12 to -7
100	-3 to -1	-8 to -3	-13 to -8

Accuracy Standards

The accuracy of the LM Guide is specified for each model in terms of the dimensional tolerance for height and width, the difference between height and width in a pair, and running parallelism.

The Model SRG has four types of accuracy standards: high accuracy grade, precision grade, super precision grade, and ultra precision grade.

■ Difference in Height M

Indicates the difference between the minimum and maximum values of height M of each LM Guide used on the same plane in combination.

■ Difference in Width W_2

Indicates a difference between the minimum and maximum values of the width W_2 between each of the LM blocks, mounted on one LM rail in combination, and the LM rail.

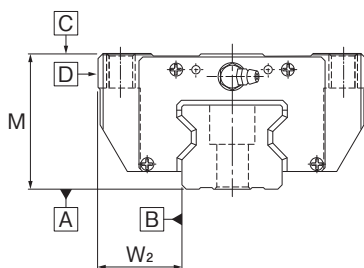

Accuracy Standards

Unit: mm

Model	Item	High accuracy grade	Precision grade	Super precision grade	Ultra precision grade
		H	P	SP	UP
15X 20X	Dimensional tolerance in height M	± 0.03	0 -0.03	0 -0.015	0 -0.008
	Difference in height M	0.01	0.006	0.004	0.003
	Dimensional tolerance in width W_2	± 0.03	0 -0.02	0 -0.015	0 -0.008
	Difference in width W_2	0.01	0.006	0.004	0.003
	Running parallelism of surface C against surface A	See the table on p. 16 for LM rail length and running parallelism by accuracy standard.			
	Running parallelism of surface D against surface B	See the table on p. 16 for LM rail length and running parallelism by accuracy standard.			
25X 30X 35	Dimensional tolerance in height M	± 0.04	0 -0.04	0 -0.02	0 -0.01
	Difference in height M	0.015	0.007	0.005	0.003
	Dimensional tolerance in width W_2	± 0.03	0 -0.03	0 -0.015	0 -0.01
	Difference in width W_2	0.015	0.007	0.005	0.003
	Running parallelism of surface C against surface A	See the table on p. 16 for LM rail length and running parallelism by accuracy standard.			
	Running parallelism of surface D against surface B	See the table on p. 16 for LM rail length and running parallelism by accuracy standard.			
45 55	Dimensional tolerance in height M	± 0.04	0 -0.05	0 -0.03	0 -0.015
	Difference in height M	0.015	0.007	0.005	0.003
	Dimensional tolerance in width W_2	± 0.04	0 -0.04	0 -0.025	0 -0.015
	Difference in width W_2	0.015	0.007	0.005	0.003
	Running parallelism of surface C against surface A	See the table on p. 16 for LM rail length and running parallelism by accuracy standard.			
	Running parallelism of surface D against surface B	See the table on p. 16 for LM rail length and running parallelism by accuracy standard.			
65 85 100	Dimensional tolerance in height M	± 0.04	0 -0.05	0 -0.04	0 -0.03
	Difference in height M	0.02	0.01	0.007	0.005
	Dimensional tolerance in width W_2	± 0.04	0 -0.05	0 -0.04	0 -0.03
	Difference in width W_2	0.02	0.01	0.007	0.005
	Running parallelism of surface C against surface A	See the table on p. 16 for LM rail length and running parallelism by accuracy standard.			
	Running parallelism of surface D against surface B	See the table on p. 16 for LM rail length and running parallelism by accuracy standard.			

Running Parallelism

Refers to the tolerance for parallelism between the LM block and the LM rail datum surface when the LM block travels the whole length of the LM rail bolted to a reference surface.

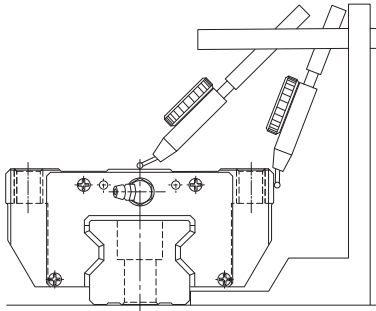

LM Rail Length and Running Parallelism by Accuracy Standard

Unit: μm

LM rail length (mm)		Running parallelism value			
Above	Or less	High accuracy grade (H)	Precision grade (P)	Super precision grade (SP)	Ultra precision grade (UP)
—	50	3	2	1.5	1
50	80	3	2	1.5	1
80	125	3	2	1.5	1
125	200	3.5	2	1.5	1
200	250	4	2.5	1.5	1
250	315	4.5	3	1.5	1
315	400	5	3.5	2	1.5
400	500	6	4.5	2.5	1.5
500	630	7	5	3	2
630	800	8.5	6	3.5	2
800	1000	9	6.5	4	2.5
1000	1250	11	7.5	4.5	3
1250	1600	12	8	5	4
1600	2000	13	8.5	5.5	4.5
2000	2500	14	9.5	6	5
2500	3090	16	11	6.5	5.5

Reference Error Tolerance for the Mounting Surface

Reference Horizontal Error Tolerance between Two Rails

Mounting surface error may affect the service life of the LM Guide. The table below shows the approximate value (P) of the reference horizontal error tolerance between two rails under normal use for each model number.

Unit: μm

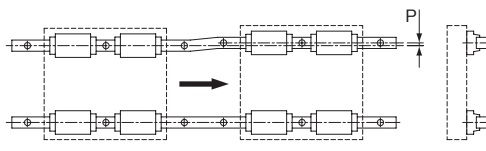

Model	Normal	Light preload	Medium preload
	No symbol	C1	C0
SRG15X	5	3	3
SRG20X	8	6	4
SRG25X	9	7	5
SRG30X	11	8	6
SRG35	14	10	7
SRG45	17	13	9
SRG55	21	14	11
SRG65	27	18	14
SRG85	40	27	21
SRG100	45	31	24

Reference Vertical Error Tolerance between Two Rails

The table shows the value (X) of the reference vertical error tolerance in the axial direction for rail span (a), which is proportional to the rail span (a).

Unit: mm

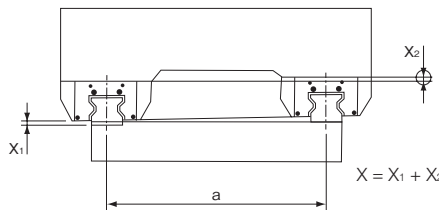

Radial clearance	Normal	Light preload	Medium preload
	No symbol	C1	C0
Reference vertical error tolerance (X)	0.00030a	0.00021a	0.00011a

$X = X_1 + X_2$
 X_1 : Difference in rail mounting surface height
 X_2 : Difference in block mounting surface height

Example Reference vertical error tolerance when rail span $a = 500$ mm
 $X = 0.0003 \times 500 = 0.15$

Reference Vertical Error Tolerance in the Axial Direction

The table below shows the value (Y) of the reference vertical error tolerance in the axial direction for block span (b), which is proportional to the block span (b).

Unit: mm

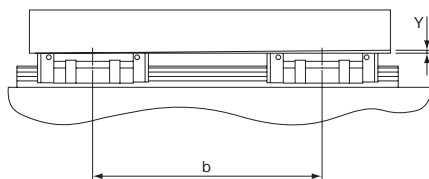

Reference vertical error tolerance (Y)	0.000036b
--	-----------

Standard and Maximum Lengths of the LM Rail

The standard and maximum lengths of Model SRG LM rails are shown in the following table. If the maximum length of the desired LM rail exceeds these values, joint rails will be used. Contact THK for details. For special rail lengths, it is recommended to use a value corresponding to the G, g dimensions from the table. As the G, g dimensions increase, that portion becomes less stable, and the accuracy may be negatively affected.

* If joint rails are not allowed, and a length greater than the maximum values is required, contact THK.

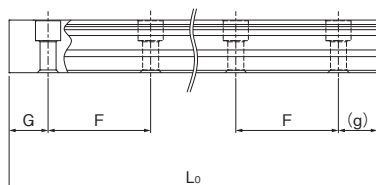

Standard Length and Maximum Length of the LM Rail

Unit: mm

Model	SRG15X	SRG20X	SRG25X	SRG30X	SRG35	SRG45	SRG55	SRG65	SRG85	SRG100
LM rail standard length (L ₀)	160	220	220	280	280	570	780	1270	1530	1340
	220	280	280	360	360	675	900	1570	1890	1760
	280	340	340	440	440	780	1020	2020	2250	2180
	340	400	400	520	520	885	1140	2620	2610	2600
	400	460	460	600	600	990	1260	—	—	—
	460	520	520	680	680	1095	1380	—	—	—
	520	580	580	760	760	1200	1500	—	—	—
	580	640	640	840	840	1305	1620	—	—	—
	640	700	700	920	920	1410	1740	—	—	—
	700	760	760	1000	1000	1515	1860	—	—	—
	760	820	820	1080	1080	1620	1980	—	—	—
	820	840	940	1160	1160	1725	2100	—	—	—
	840	940	1000	1240	1240	1830	2220	—	—	—
	940	1000	1060	1320	1320	1935	2340	—	—	—
	1000	1060	1120	1400	1400	2040	2460	—	—	—
	1060	1120	1180	1480	1480	2145	2580	—	—	—
	1120	1180	1240	1560	1560	2250	2700	—	—	—
	1180	1240	1300	1640	1640	2355	2820	—	—	—
	1240	1360	1360	1720	1720	2460	2940	—	—	—
	1360	1480	1420	1800	1800	2565	3060	—	—	—
1480	1600	1480	1880	1880	2670	—	—	—	—	
1600	1720	1540	1960	1960	2775	—	—	—	—	
—	1840	1600	2040	2040	2880	—	—	—	—	
—	1960	1720	2200	2200	2985	—	—	—	—	
—	2080	1840	2360	2360	3090	—	—	—	—	
—	2200	1960	2520	2520	—	—	—	—	—	
—	—	2080	2680	2680	—	—	—	—	—	
—	—	2200	2840	2840	—	—	—	—	—	
—	—	2320	3000	3000	—	—	—	—	—	
—	—	2440	—	—	—	—	—	—	—	
Standard pitch F	30	30	30	40	40	52.5	60	75	90	105
G, g dimension	20	20	20	20	20	22.5	30	35	45	40
Maximum length	3000	3000	3000	3000	3000	3090	3060	3000	3000	3000

LM Rail Tapped-Hole Type

Tapped-hole type LM rails with tapped holes machined on the bottom surface are available for the Model SRG. This type is effective in situations where you want to mount from the bottom surface of the base or increase dust protection.

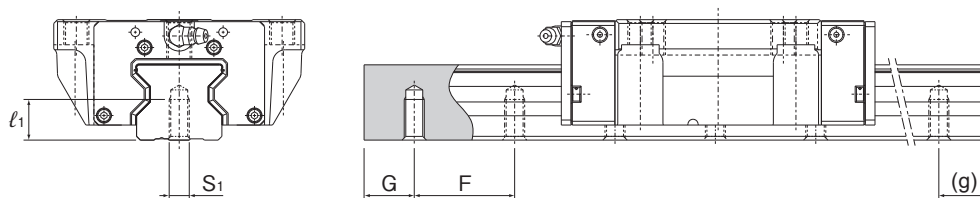

- (1) The Model SRG tapped-hole type LM rail is only produced at precision grade and below.
- (2) For standard tap pitch (F) and G, g dimensions, see "Standard and Maximum Lengths of the LM Rail."

Model Number Coding

SRG30XC2UU+1000LP K

LM rail tapped-hole type symbol

LM Rail Tapped Hole

Unit: mm

Model	S ₁	Effective tap depth l ₁
SRG15X	M4	8
SRG20X	M5	10
SRG25X	M6	12
SRG30X	M8	16
SRG35	M8	16
SRG45	M12	24
SRG55	M14	28
SRG65	M16	32

Shoulder Height of the Mounting Base and the Corner Radius

The mounting base for the LM rail and LM block has a reference surface on the side face to allow easy installation. The height of the datum shoulder varies based on the model. See below for details. The corner of the mounting shoulder must be machined to have a recess, or machined to be smaller than the corner radius r , to prevent interference with the chamfer of the LM rail or the LM block. The corner radius r varies based on the model. See below for details.

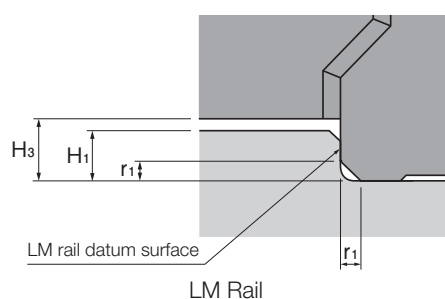
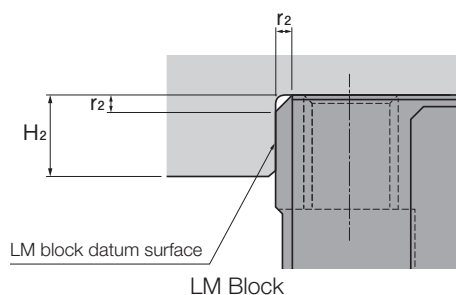

Shoulder Height of the Mounting Base and the Corner Radius Unit: mm

Model	LM rail corner radius r_1 (max)	LM block corner radius r_2 (max)	LM rail shoulder height H_1	LM block shoulder height H_2	H_3
15X	0.5	0.5	2.5	4	4
20X	0.5	0.5	3.5	5	4.6
25X	1	1	3.5	5	4.5
30X	1	1	4	5	5
35	1	1	5	6	6
45	1.5	1.5	6	8	8
55	1.5	1.5	8	10	10
65	1.5	2	9	10	11.5
85	1.5	1.5	12	14	16
100	2	2	12	16	16

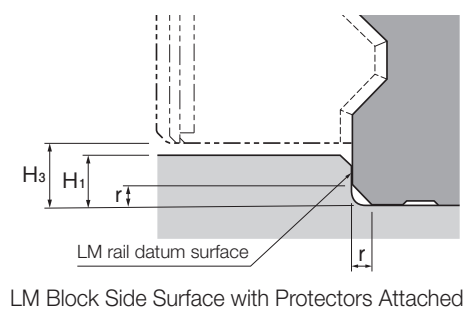

Shoulder Height of the Mounting Base and the Corner Radius with Protectors Attached Unit: mm

Model	Corner radius r (max)	LM rail shoulder height H_1	H_3
30X	1	4	5
35	1	5	6
45	1.5	6	8
55	1.5	8	10
65	1.5	9	11.5

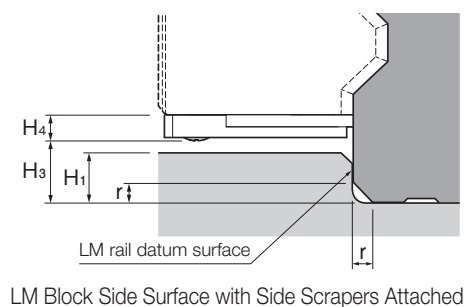

Shoulder Height of the Mounting Base and the Corner Radius with Side Scrapers Attached Unit: mm

Model	Corner radius r (max)	LM rail shoulder height H_1	H_3	Side scraper thickness H_4
35	1	3	4	2
45	1	3.5	5.5	2.5
55	1.5	5	7	3
65	1.5	6	8.5	3

Specification Table

SRG-A/LA, SRG-C/LC

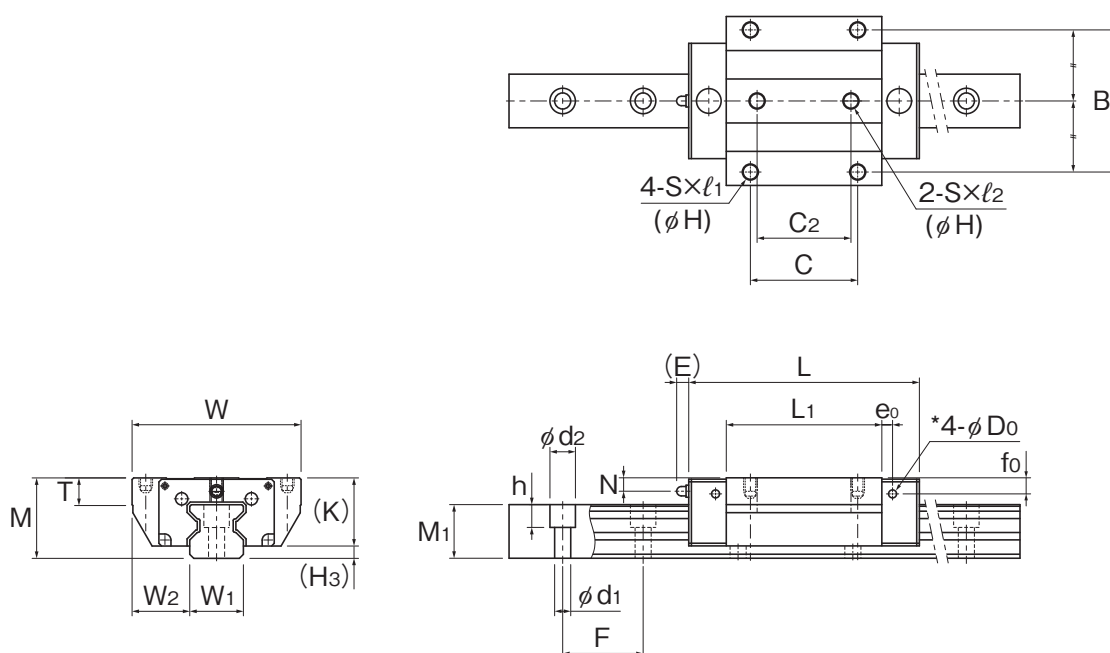

SRG15X, 20X A/LA

Model	External dimensions			LM block dimensions																	
	Height M	Width W	Length L	B	C	C ₂	S	H*	ø ₁	ø ₂	L ₁	T	T ₁ *	K	N	E	e ₀	f ₀	D ₀	Grease nipple	
SRG 15XA	24	47	69.2	38	30	26	M5	(4.3)	8	7.5	45	7	(8)	20	4	4.5	4	6	2.9	PB107	
SRG 20XA SRG 20XLA	30	63	86.2 106.2	53	40	35	M6	(5.4)	10	9	58 78	10	(10)	25.4	5	4.5	4	6	2.9	PB107	
SRG 25XC SRG 25XLC	36	70	95.1 115.1	57	45	40	M8	6.8	—	—	65.5 85.5	9.5	10	31.5	5.5	12	6	7.3	5.2	B-M6F	
SRG 30XC SRG 30XLC	42	90	111 135	72	52	44	M10	8.5	—	—	75 99	12	14	37	6.5	12	6	7.5	5.2	B-M6F	

Model Number Coding

Select an option * Specify each item for the models in the catalog.

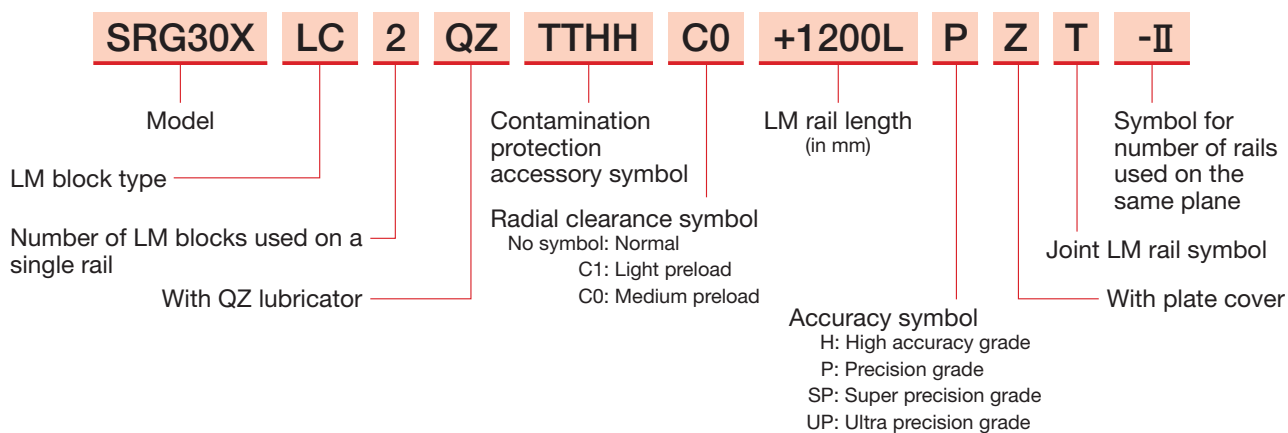

Note) For this model, one guide unit is considered one set. (When using two guides in parallel, two sets will be needed.)
Grease nipples are not installed when there is a QZ Lubricator. Contact THK if you want to use a grease nipple for a model with a QZ.

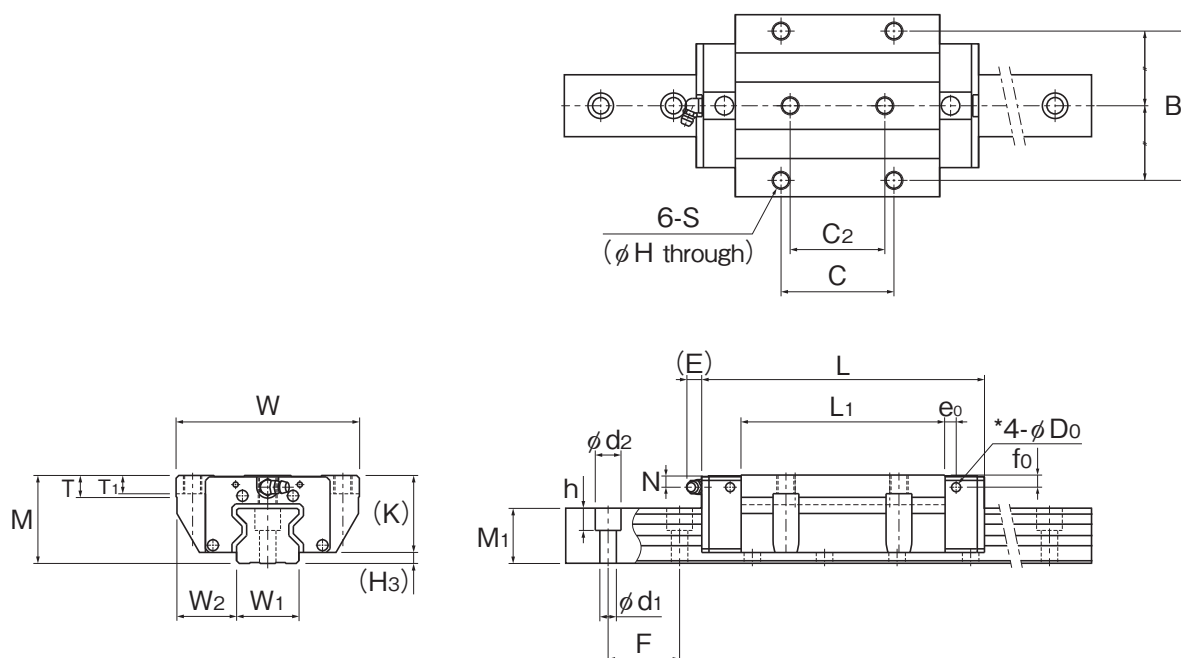

SRG25X, 30X C/LC

Unit: mm

H ₃	LM rail dimensions							Basic load rating*		Static permissible moment* kN·m					Mass	
	W ₁ 0 -0.05	W ₂	M ₁	Pitch	F	d ₁ × d ₂ × h	Length* Max	C kN	C ₀ kN	M _A		M _B		M _C	LM block kg	LM rail kg/m
										1 block	2 blocks	1 block	2 blocks			
4	15	16	15.5	30	4.5 × 7.5 × 5.3	3000	11.3	25.8	0.21	1.24	0.21	1.24	0.24	0.2	1.58	
4.6	20	21.5	20	30	6 × 9.5 × 8.5	3000	21 26.7	46.9 63.8	0.48 0.88	2.74 4.49	0.48 0.88	2.74 4.49	0.58 0.79	0.42 0.57	2.58	
4.5	23	23.5	23	30	7 × 11 × 9	3000	27.9 34.2	57.5 75	0.64 1.07	3.7 5.74	0.64 1.07	3.7 5.74	0.8 1.03	0.7 0.9	3.6	
5	28	31	26	40	9 × 14 × 12	3000	39.3 48.3	82.5 108	1.02 1.76	6.21 9.73	1.02 1.76	6.21 9.73	1.47 1.92	1.2 1.6	4.4	

Note 1) Length* Max represents the standard maximum length of an LM rail.

Static permissible moment* 1 block: Static permissible moment with 1 LM block

2 blocks: Static permissible moment during use with 2 LM blocks in close contact with each other

When using oil lubrication, be sure to let THK know the mounting orientation and the position where the pipe fitting will be attached to the LM block.

Overall block length dimension (L) The overall block lengths (L) in the dimension table are for when the contamination protection accessory symbol is UU or SS. The overall block length (L) will increase if another contamination protection accessory or lubricator is attached.

The removing/mounting jig is not provided as standard. To obtain one, please contact THK.

* The diagram shows the side nipple pilot holes for when a grease nipple is desired for a product with LaCS or a QZ Lubricator.

In all other cases, the side nipple pilot holes will not be through holes.

Contact THK if you desire machining for grease nipple mounting.

Note 2) H*, T₁* If the mounting holes (4 holes) of the LM block are back spot-faced, these models can be mounted on the table from the top and the bottom as with the Model SRG-C.

The values in parentheses are the dimensions when back spot-faced.

Contact THK for details.

Note 3) The basic dynamic load rating for an LM Guide with rollers is based on a nominal life of 100 km.

The following formula can be used to convert to a basic dynamic load rating based on a nominal life of 50 km.

$$C_{50} = C \times 1.23$$

C₅₀: Basic dynamic load rating based on a load rating of 50 km

C: Basic dynamic load rating in the dimension table

Specification Table

SRG-C/LC/SLC

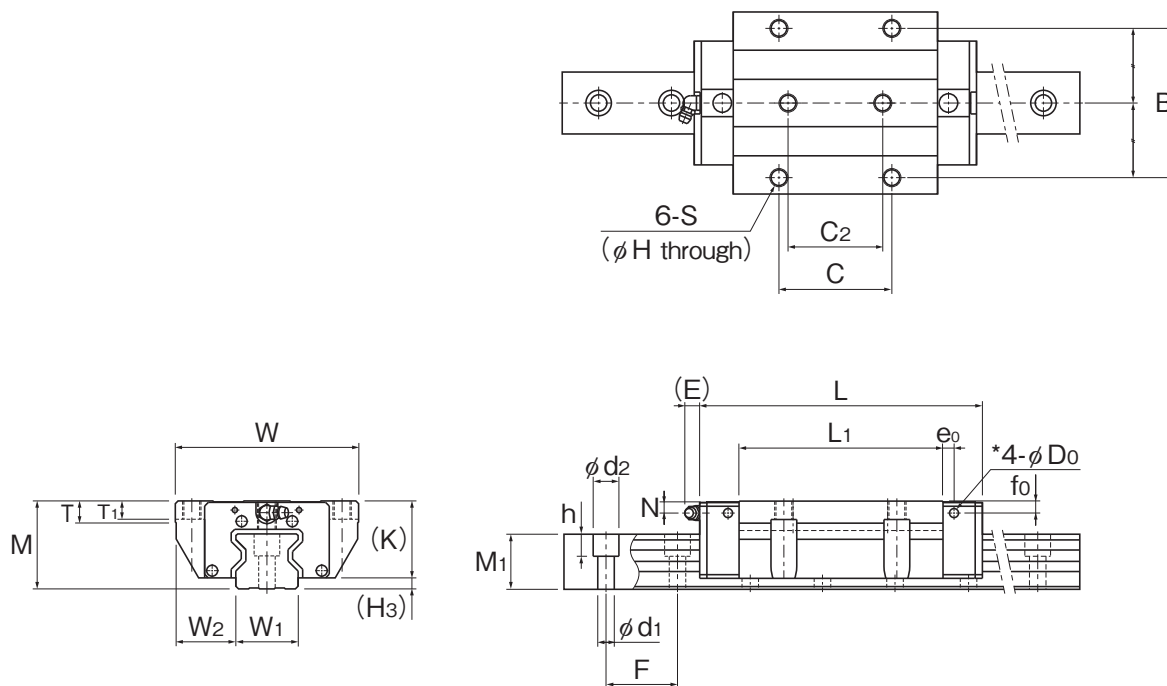

SRG35 to 65C/LC

Model	External dimensions			LM block dimensions																	
	Height M	Width W	Length L	B	C	C ₂	S	H	l ₁	l ₂	L ₁	T	T ₁	K	N	E	e ₀	f ₀	D ₀	Grease nipple	
SRG 35C SRG 35LC SRG 35SLC	48	100	125 155 180.8	82	62 62 100	52 52 —	M10	8.5	—	—	82.2 112.2 138	11.5	10	42	6.5	12	6	6	5.2	B-M6F	
SRG 45C SRG 45LC SRG 45SLC	60	120	155 190 231.5	100	80 80 120	60 60 —	M12	10.5	—	—	107 142 183.5	14.5	15	52	10	16	7	7	5.2	B-PT1/8	
SRG 55C SRG 55LC SRG 55SLC	70	140	185 235 292	116	95 95 150	70 70 —	M14	12.5	—	—	129.2 179.2 236.2	17.5	18	60	12	16	9	8.5	5.2	B-PT1/8	
SRG 65C SRG 65LC SRG 65SLC	90	170	244.9 303 380	142	110 110 200	82 82 —	M16	14.5	—	—	171.7 229.8 306.8	19.5	20	78.5	17	16	9	13.5	5.2	B-PT1/8	
SRG 85LC	110	215	350	185	140	—	M20	17.8	—	—	250.8	30	35	94	22	16	15	22	8.2	B-PT1/8	
SRG 100LC	120	250	395	220	200	—	M20	17.8	—	—	280.2	35	38	104	23	16	15	23	8.2	B-PT1/4	

Model Number Coding

Select an option * Specify each item for the models in the catalog.

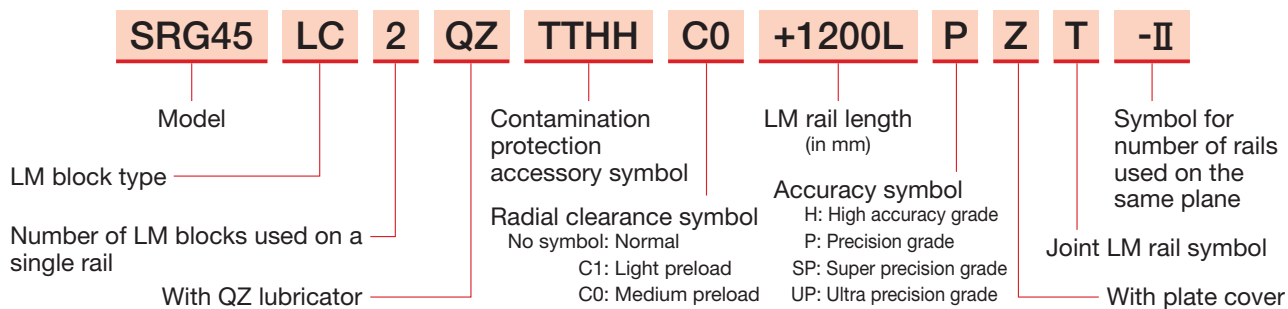

Note) For this model, one guide unit is considered one set. (When using two guides in parallel, two sets will be needed.)

Grease nipples are not installed when there is a QZ Lubricator. Contact THK if you want to use a grease nipple for a model with a QZ.

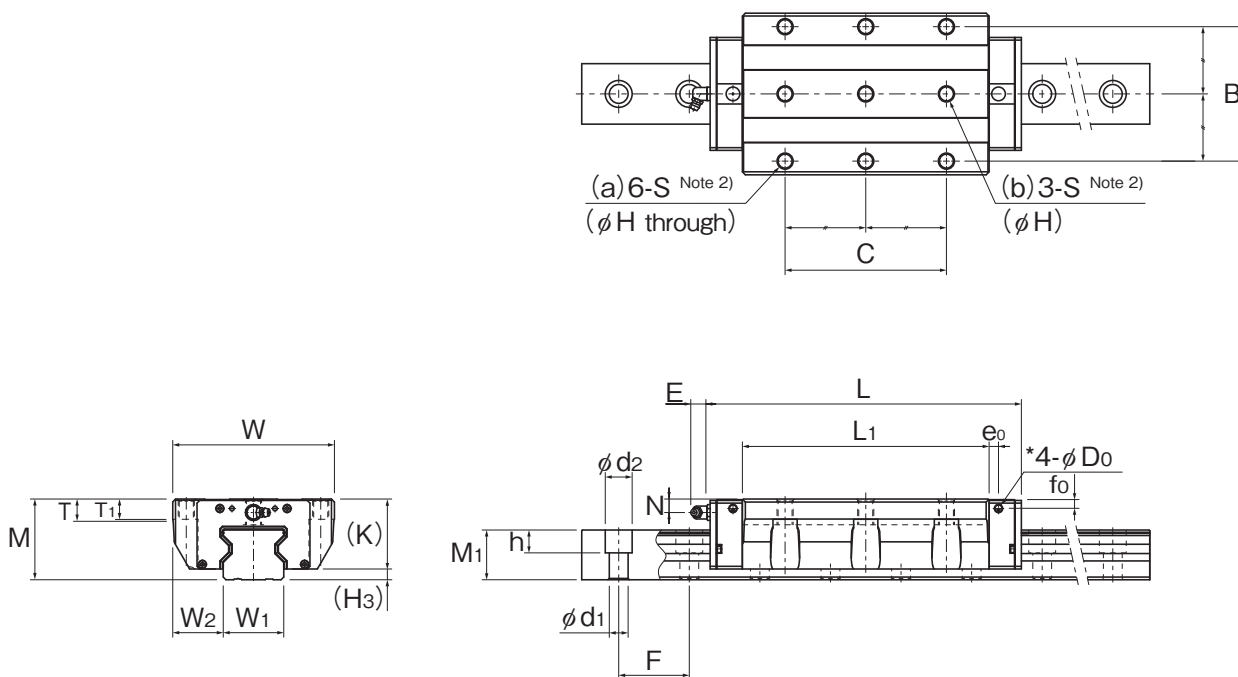

SRG35 to 65SLC, 85LC, 100LC

Unit: mm

H ₃	LM rail dimensions						Basic load rating*		Static permissible moment* kN·m					Mass	
	W ₁ 0 -0.05	W ₂	M ₁	F	d ₁ × d ₂ × h	Length* Max	C kN	C ₀ kN	M _A		M _B		M _C	LM block	LM rail
									1 block	2 blocks	1 block	2 blocks	1 block	kg	kg/m
6	34	33	30	40	9 × 14 × 12	3000	59.1 76 87.9	119 165 199	1.66 3.13 4.53	10.1 17 23.9	1.66 3.13 4.53	10.1 17 23.9	2.39 3.31 4.09	1.9 2.4 3.2	6.9
8	45	37.5	37	52.5	14 × 20 × 17	3090	91.9 115 139	192 256 328	3.49 6.13 9.99	20 32.2 50	3.49 6.13 9.99	20 32.2 50	4.98 6.64 8.91	3.7 4.5 6.3	11.6
10	53	43.5	43	60	16 × 23 × 20	3060	131 167 210	266 366 488	5.82 10.8 19.1	33 57 93.7	5.82 10.8 19.1	33 57 93.7	8.19 11.2 15.6	5.9 7.8 10.7	15.8
11.5	63	53.5	54	75	18 × 26 × 22	3000	219 278 352	441 599 811	12.5 22.7 41.3	72.8 120 202	12.5 22.7 41.3	72.8 120 202	16.8 22.1 30.9	12.5 16.4 22.3	23.7
16	85	65	71	90	24 × 35 × 28	3000	497	990	45.3	239	45.3	239	51.9	26.2	35.7
16	100	75	77	105	26 × 39 × 32	3000	601	1170	60	319	60	319	72.3	37.6	46.8

Note 1) Length* Max represents the standard maximum length of an LM rail.

Static permissible moment*

1 block: Static permissible moment value with 1 LM block

2 blocks: Static permissible moment during use with 2 LM blocks in close contact with each other

When using oil lubrication, be sure to let THK know the mounting orientation and the position where the pipe fitting will be attached to the LM block.

Overall block length dimension (L)

The overall block lengths (L) in the dimension table are for when the contamination protection accessory symbol is UU or SS. The overall block length (L) will increase if another contamination protection accessory or lubricator is attached.

The removing/mounting jig is not provided as standard. To obtain one, please contact THK.

* The diagram shows the side nipple pilot holes for when a grease nipple is desired for a product with LaCS or a QZ Lubricator.

In all other cases, the side nipple pilot holes will not be through holes.

Contact THK if you desire machining for grease nipple mounting.

Note 2) The nine LM block mounting holes in parts (a) and (b) for SRG35 to 65SLC and SRG85LC are all through holes (fully threaded).

The six LM block mounting holes in part (a) for SRG100LC are through holes (fully threaded).

The three LM block mounting holes in part (b) have an effective thread depth of 22 mm.

Note 3) The basic dynamic load rating for an LM Guide with rollers is based on a nominal life of 100 km.

The following formula can be used to convert to a basic dynamic load rating based on a nominal life of 50 km.

$$C_{50} = C \times 1.23$$

C₅₀: Basic dynamic load rating based on a load rating of 50 km
C : Basic dynamic load rating in the dimension table

Specification Table

SRG-V/LV, SRG-R/LR

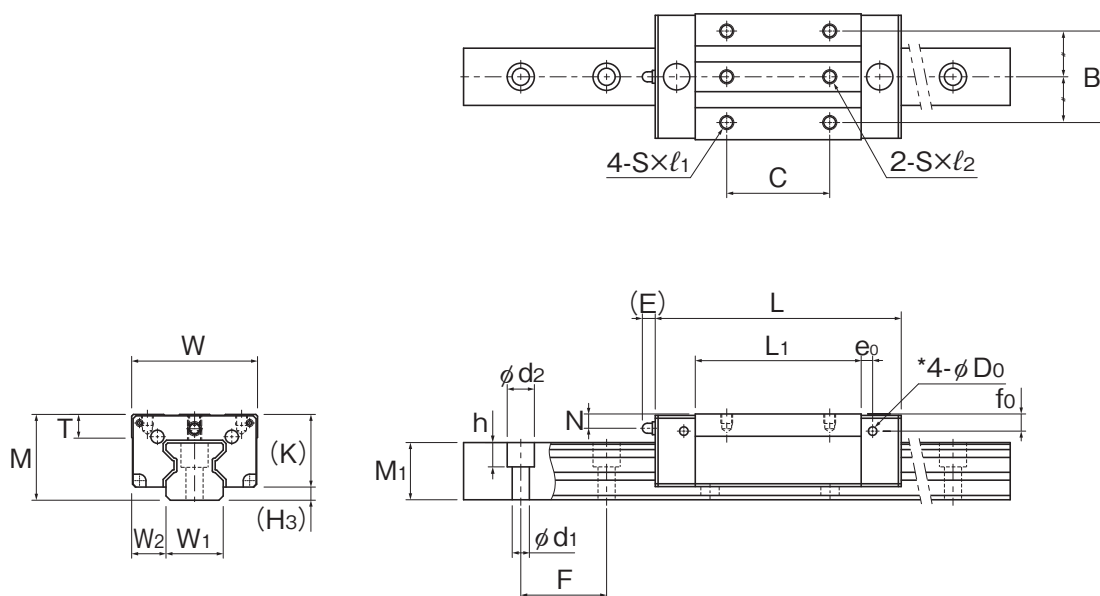

SRG15X, 20X V/LV

Model	External dimensions			LM block dimensions															
	Height M	Width W	Length L	B	C	S	l	l ₁	l ₂	L ₁	T	K	N	E	e ₀	f ₀	D ₀	Grease nipple	
SRG 15XV	24	34	69.2	26	26	M4	—	5	7.5	45	6	20	4	4.5	4	6	2.9	PB107	
SRG 20XV SRG 20XLV	30	44	86.2 106.2	32	36 50	M5	—	7	9	58 78	8	25.4	5	4.5	4	6	2.9	PB107	
SRG 25XR SRG 25XLR	40	48	95.1 115.1	35	35 50	M6	9	—	—	65.5 85.5	9.5	35.5	9.5	12	6	11.3	5.2	B-M6F	
SRG 30XR SRG 30XLR	45	60	111 135	40	40 60	M8	10	—	—	75 99	12	40	9.5	12	6	10.5	5.2	B-M6F	

Model Number Coding

Select an option * Specify each item for the models in the catalog.

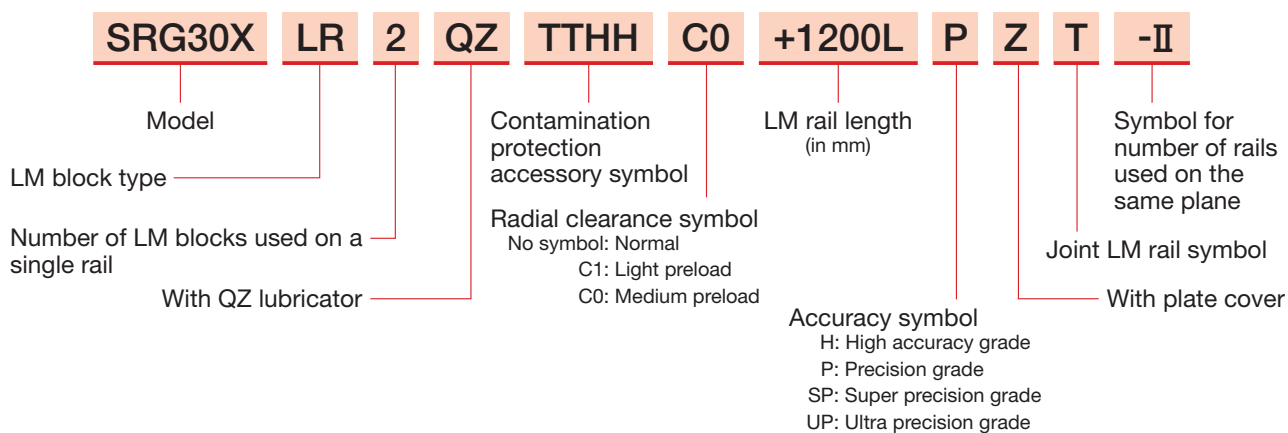

(Note) For this model, one guide unit is considered one set. (When using two guides in parallel, two sets will be needed.)
 Grease nipples are not installed when there is a QZ Lubricator. Contact THK if you want to use a grease nipple for a model with a QZ.

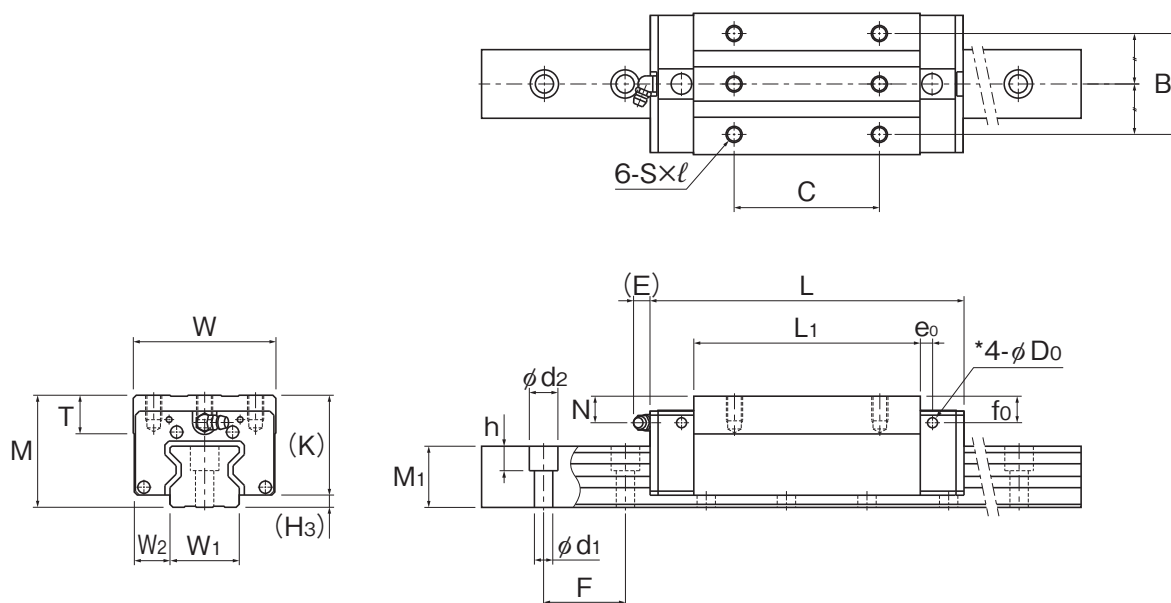

SRG25X, 30X R/LR

Unit: mm

H ₃	LM rail dimensions							Basic load rating*		Static permissible moment* kN·m					Mass	
	W ₁ 0 -0.05	W ₂	M ₁	Pitch F	d ₁ × d ₂ × h	Length* Max	C kN	C ₀ kN	M _A		M _B		M _C	LM block	LM rail	
									1 block	2 blocks	1 block	2 blocks	1 block	kg	kg/m	
4	15	9.5	15.5	30	4.5 × 7.5 × 5.3	3000	11.3	25.8	0.21	1.24	0.21	1.24	0.24	0.15	1.58	
4.6	20	12	20	30	6 × 9.5 × 8.5	3000	21 26.7	46.9 63.8	0.48 0.88	2.74 4.49	0.48 0.88	2.74 4.49	0.58 0.79	0.28 0.38	2.58	
4.5	23	12.5	23	30	7 × 11 × 9	3000	27.9 34.2	57.5 75	0.64 1.07	3.7 5.74	0.64 1.07	3.7 5.74	0.8 1.03	0.6 0.8	3.6	
5	28	16	26	40	9 × 14 × 12	3000	39.3 48.3	82.5 108	1.02 1.76	6.21 9.73	1.02 1.76	6.21 9.73	1.47 1.92	0.9 1.2	4.4	

Note 1) Length* Max represents the standard maximum length of an LM rail.

Static permissible moment* 1 block: Static permissible moment value with 1 LM block

2 blocks: Static permissible moment during use with 2 LM blocks in close contact with each other

When using oil lubrication, be sure to let THK know the mounting orientation and the position where the pipe fitting will be attached to the LM block.

Overall block length dimension (L) The overall block lengths (L) in the dimension table are for when the contamination protection accessory symbol is UU or SS. The overall block length (L) will increase if another contamination protection accessory or lubricator is attached.

The removing/mounting jig is not provided as standard. To obtain one, please contact THK.

* The diagram shows the side nipple pilot holes for when a grease nipple is desired for a product with LaCS or a QZ Lubricator.

In all other cases, the side nipple pilot holes will not be through holes.

Contact THK if you desire machining for grease nipple mounting.

Note 2) The basic dynamic load rating for an LM Guide with rollers is based on a nominal life of 100 km.

The following formula can be used to convert to a basic dynamic load rating based on a nominal life of 50 km.

$$C_{50} = C \times 1.23$$

C₅₀: Basic dynamic load rating based on a load rating of 50 km

C: Basic dynamic load rating in the dimension table

Specification Table

SRG-V/LV/SLV, SRG-R/LR/SLR

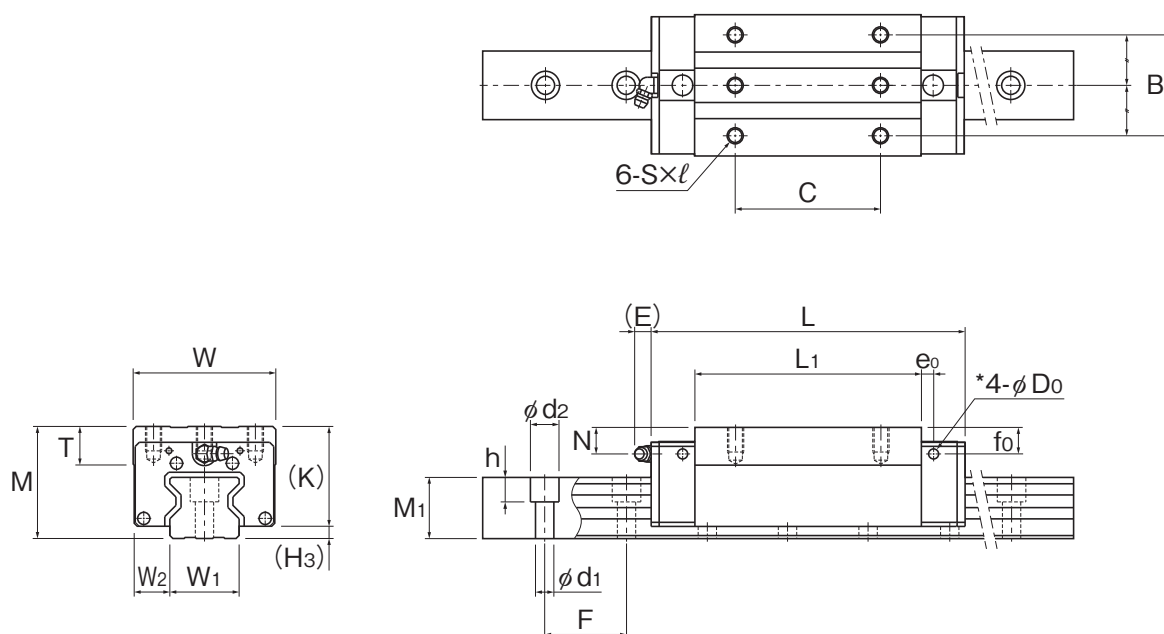

SRG35 to 65R/V/LR/LV

Model	External dimensions			LM block dimensions																
	Height M	Width W	Length L	B	C	S	l	l ₁	l ₂	L ₁	T	K	N	E	e ₀	f ₀	D ₀	Grease nipple		
SRG 35R SRG 35LR SRG 35SLR	55	70	125 155 180.8	50	50 72 100	M8	12	—	—	82.2 112.2 138	18.5	49	13.5	12	6	13	5.2	B-M6F		
SRG 45R SRG 45LR SRG 45SLR	70	86	155 190 231.5	60	60 80 120	M10	20	—	—	107 142 183.5	24.5	62	20	16	7	17	5.2	B-PT1/8		
SRG 55R SRG 55LR SRG 55SLR	80	100	185 235 292	75	75 95 150	M12	18	—	—	129.2 179.2 236.2	27.5	70	22	16	9	18.5	5.2	B-PT1/8		
SRG 65V SRG 65LV SRG 65SLV	90	126	244.9 303 380	76	70 120 200	M16	20	—	—	171.7 229.8 306.8	19.5	78.5	17	16	9	13.5	5.2	B-PT1/8		

Model Number Coding

Select an option * Specify each item for the models in the catalog.

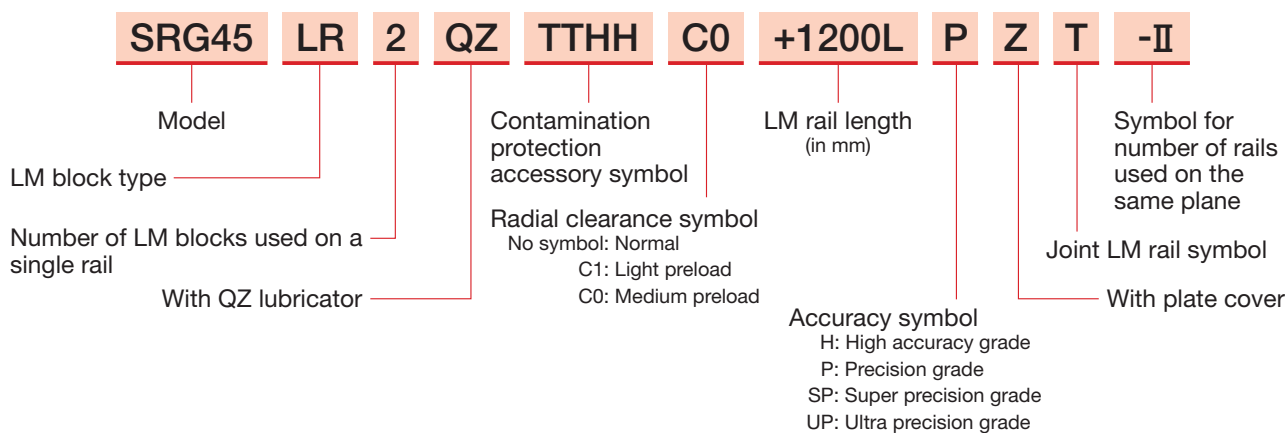

Note) For this model, one guide unit is considered one set. (When using two guides in parallel, two sets will be needed.)
Grease nipples are not installed when there is a QZ Lubricator. Contact THK if you want to use a grease nipple for a model with a QZ.

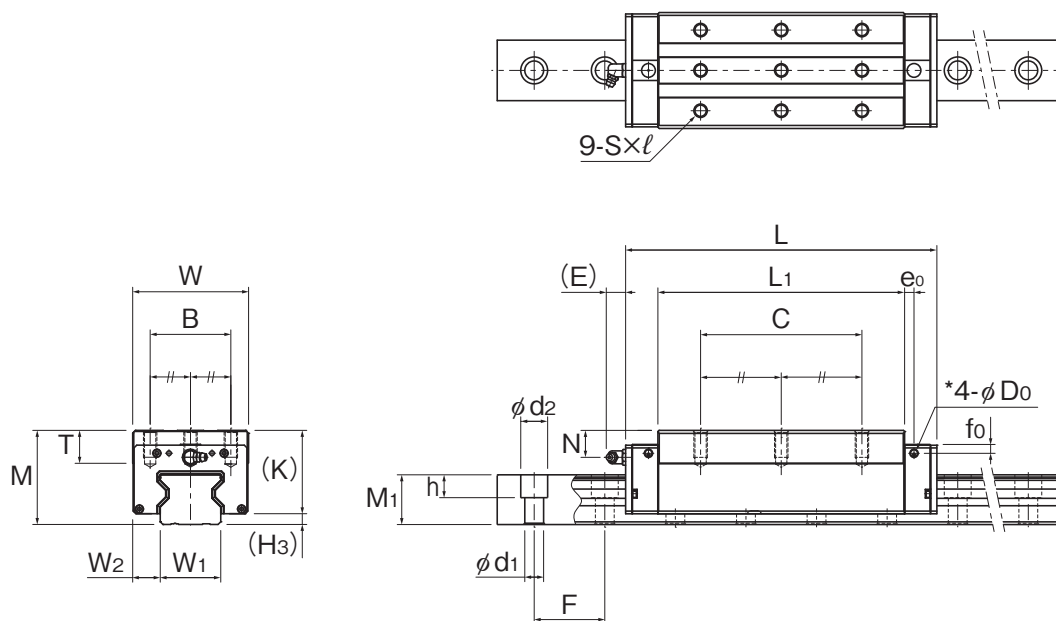

SRG35 to 55SLR, SRG65SLV

Unit: mm

H ₃	LM rail dimensions						Basic load rating*		Static permissible moment* kN-m					Mass	
	W ₁ 0 -0.05	W ₂	M ₁	F	d ₁ × d ₂ × h	Length* Max	C kN	C ₀ kN	M _A		M _B		M _C	LM block	LM rail
									1 block	2 blocks	1 block	2 blocks	1 block	kg	kg/m
6	34	18	30	40	9 × 14 × 12	3000	59.1 76 87.9	119 165 199	1.66 3.13 4.53	10.1 17 23.9	1.66 3.13 4.53	10.1 17 23.9	2.39 3.31 4.09	1.6 2.1 2.6	6.9
8	45	20.5	37	52.5	14 × 20 × 17	3090	91.9 115 139	192 256 328	3.49 6.13 9.99	20 32.2 50	3.49 6.13 9.99	20 32.2 50	4.98 6.64 8.91	3.2 4.1 5.4	11.6
10	53	23.5	43	60	16 × 23 × 20	3060	131 167 210	266 366 488	5.82 10.8 19.1	33 57 93.7	5.82 10.8 19.1	33 57 93.7	8.19 11.2 15.6	5 6.9 9.2	15.8
11.5	63	31.5	54	75	18 × 26 × 22	3000	219 278 352	441 599 811	12.5 22.7 41.3	72.8 120 202	12.5 22.7 41.3	72.8 120 202	16.8 22.1 30.9	9 12.1 16.1	23.7

Note 1) Length* Max represents the standard maximum length of an LM rail.

Static permissible moment*

1 block: Static permissible moment value with 1 LM block

2 blocks: Static permissible moment during use with 2 LM blocks in close contact with each other

When using oil lubrication, be sure to let THK know the mounting orientation and the position where the pipe fitting will be attached to the LM block.

Overall block length dimension (L)

The overall block lengths (L) in the dimension table are for when the contamination protection accessory symbol is UU or SS. The overall block length (L) will increase if another contamination protection accessory or lubricator is attached.

The removing/mounting jig is not provided as standard. To obtain one, please contact THK.

* The diagram shows the side nipple pilot holes for when a grease nipple is desired for a product with LaCS or a QZ Lubricator.

In all other cases, the side nipple pilot holes will not be through holes.

Contact THK if you desire machining for grease nipple mounting.

Note 2) The basic dynamic load rating for an LM Guide with rollers is based on a nominal life of 100 km.

The following formula can be used to convert to a basic dynamic load rating based on a nominal life of 50 km.

$$C_{50} = C \times 1.23$$

C₅₀: Basic dynamic load rating based on a load rating of 50 km
C: Basic dynamic load rating in the dimension table

Feature 4 LM Blocks and LM Rails Available for Individual Sale

SRG-GK

LM blocks and LM rails available for individual sale

Flexible combinations, simple, quick



Lineup

Block type		SRG15X	SRG20X	SRG25X	SRG30X	SRG35	SRG45
Standard type	A	○	○	—	—	—	—
	C	—	—	○	○	○	○
	R	—	—	○	○	○	○
	V	○	○	—	—	—	—
Long type	LA	—	○	—	—	—	—
	LC	—	—	○	○	○	○
	LR	—	—	○	○	○	○
	LV	—	○	—	—	—	—

○: Available, —: Not available

Model Number Coding

Select an option (orange box) Fixed symbol (grey box)

LM rail

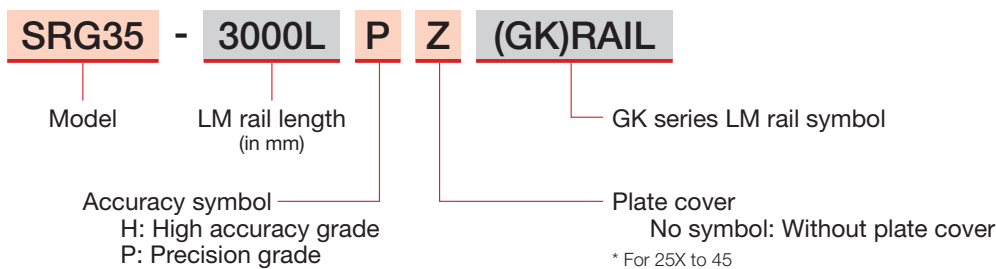

LM block

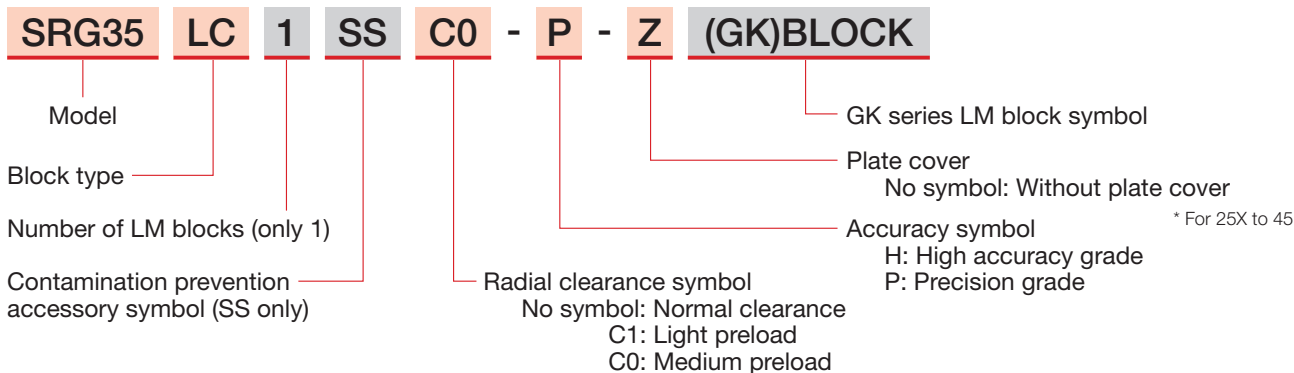

Radial Clearance Specifications

The Model SRG has three types of radial clearance (preload): normal, light preload, and medium preload.

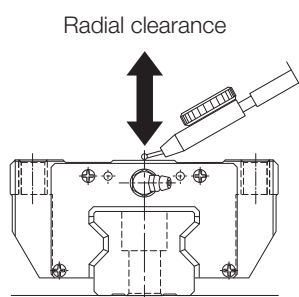

Radial Clearance Specifications Unit: μm

Model	Normal	Light preload	Medium preload
	No symbol	C1	C0
15X	-0.5 to 0	-1 to -0.5	-2 to -1
20X	-0.8 to 0	-2 to 0.8	-3 to -2
25X	-2 to -1	-3 to -2	-4 to -3
30X	-2 to -1	-3 to -2	-4 to -3
35	-2 to -1	-3 to -2	-5 to -3
45	-2 to -1	-3 to -2	-5 to -3

Accuracy Standards

The accuracy of the LM Guide is specified for each model in terms of the dimensional tolerance for height and width, the difference between height and width in a pair, and running parallelism. The SRG-GK has two types of accuracy standards: high accuracy grade and precision grade.

■ Difference in Height M

Indicates the difference between the minimum and maximum values of height M of each LM Guide used on the same plane in combination.

■ Difference in Width W_2

Indicates a difference between the minimum and maximum values of the width W_2 between each of the LM blocks, mounted on one LM rail in combination, and the LM rail.

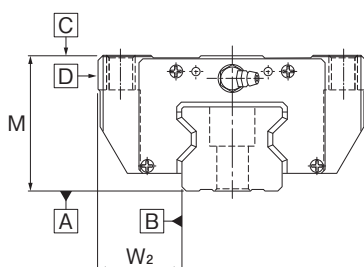

Accuracy Standards Unit: mm

Model	Item		High accuracy grade	Precision grade
			H	P
15X 20X	Dimensional tolerance in height M		± 0.03	$\begin{matrix} 0 \\ -0.03 \end{matrix}$
	Difference in height M	Multiple blocks on a single rail (1 set)	0.01	0.006
	Dimensional tolerance in width W_2		± 0.03	$\begin{matrix} 0 \\ -0.02 \end{matrix}$
	Difference in width W_2		0.01	0.006
	Running parallelism of surface C against surface A		See the table on p. 16 for LM rail length and running parallelism by accuracy standard.	
Running parallelism of surface D against surface B		See the table on p. 16 for LM rail length and running parallelism by accuracy standard.		
25X 30X 35	Dimensional tolerance in height M		± 0.04	$\begin{matrix} 0 \\ -0.04 \end{matrix}$
	Difference in height M	Multiple blocks on a single rail (1 set)	0.015	0.007
	Dimensional tolerance in width W_2		± 0.03	$\begin{matrix} 0 \\ -0.03 \end{matrix}$
	Difference in width W_2		0.015	0.007
	Running parallelism of surface C against surface A		See the table on p. 16 for LM rail length and running parallelism by accuracy standard.	
Running parallelism of surface D against surface B		See the table on p. 16 for LM rail length and running parallelism by accuracy standard.		
45	Dimensional tolerance in height M		± 0.04	$\begin{matrix} 0 \\ -0.05 \end{matrix}$
	Difference in height M	Multiple blocks on a single rail (1 set)	0.015	0.007
	Dimensional tolerance in width W_2		± 0.04	$\begin{matrix} 0 \\ -0.04 \end{matrix}$
	Difference in width W_2		0.015	0.007
	Running parallelism of surface C against surface A		See the table on p. 16 for LM rail length and running parallelism by accuracy standard.	
Running parallelism of surface D against surface B		See the table on p. 16 for LM rail length and running parallelism by accuracy standard.		

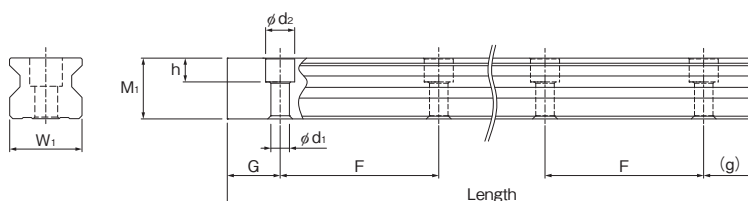

LM Rail Dimensions

Unit: mm

Model	LM rail dimensions						Mass
	$\begin{matrix} W_1 \\ 0 \\ -0.05 \end{matrix}$	W_2	M_1	F	$d_1 \times d_2 \times h$	Length (G, g)	kg/m
SRG15X	15	16	15.5	30	$4.5 \times 7.5 \times 5.3$	3000 (20, 10)	1.58
SRG20X	20	21.5	20	30	$6 \times 9.5 \times 8.5$	3000 (20, 10)	2.58
SRG25X	23	23.5	23	30	$7 \times 11 \times 9$	3000 (20, 10)	3.6
SRG30X	28	31	26	40	$9 \times 14 \times 12$	3000 (20, 20)	4.4
SRG35	34	33	30	40	$9 \times 14 \times 12$	3000 (20, 20)	6.9
SRG45	45	37.5	37	52.5	$14 \times 20 \times 17$	3000 (20, 40)	11.6

Calculating the Static Safety Factor, Nominal Life, and Service Life Time of the SRG and SRG-GK

Static Safety Factor

To calculate a load applied to the LM Guide, you must first obtain the average load required to determine the service life and the maximum load needed to determine the static safety factor. In particular, if the system starts and stops frequently, if a cutting load acts on the system, or if a large moment caused by an overhanging load is applied, it may experience an unexpectedly large load. When selecting a model number, make sure that the desired model is capable of supporting the required maximum load (whether stationary or in motion). The reference values for the static safety factor are shown in the table to the right.

Reference Values for the Static Safety Factor (f_s)

Machine	Load conditions	Lower limit of f_s
General industrial machinery	Without vibrations or impacts	1.0 to 3.5
	With vibrations or impacts	2.0 to 5.0
Machine tools	Without vibrations or impacts	1.0 to 4.0
	With vibrations or impacts	2.5 to 7.0

* The reference values of the static safety factor may vary depending on usage conditions such as environment, lubrication status, mounting surface accuracy, and/or rigidity.

$$f_s = \frac{C_0}{P_{max}}$$

f_s : Static safety factor

C_0 : Basic static load rating (N)

P_{max} : Maximum applied load (N)

Nominal Life and Service Life Time

Calculating the Nominal Life

The nominal life (L_{10}) is obtained from the following formulas using the basic dynamic load rating (C) and the calculated load acting on the LM Guide (P_c). For this calculation, the basic dynamic load is to be based on a nominal life of 50 km in case of an LM Guide with balls, or 100 km in case of an LM Guide with rollers.

LM Guide with balls
(Using a basic dynamic load rating such that the nominal life will be 50 km)

$$L_{10} = \left(\frac{C}{P_c} \right)^3 \times 50$$

L_{10} : Nominal life (km)

C: Basic dynamic load rating (N)

P_c : Calculated load (N)

LM Guide with rollers
(Using a basic dynamic load rating such that the nominal life will be 100 km)

$$L_{10} = \left(\frac{C}{P_c} \right)^{\frac{10}{3}} \times 100$$

*These nominal life formulas may not apply if the length of the stroke is less than or equal to twice the length of the LM block.

When comparing the nominal life (L_{10}), you must take into account whether the basic dynamic load rating was defined based on 50 km or 100 km. Convert the basic dynamic load rating based on ISO 14728-1 as necessary.

ISO-regulated basic dynamic load rating conversion formulas:

- LM Guide with balls (Formula 1)

$$C_{100} = \frac{C_{50}}{1.26}$$

C_{50} : Basic dynamic load based on a nominal life of 50 km

- LM Guide with rollers (Formula 2)

$$C_{100} = \frac{C_{50}}{1.23}$$

C_{100} : Basic dynamic load based on a nominal life of 100 km

Calculating the Modified Nominal Life

During use, an LM Guide may be subjected to vibrations and shocks as well as fluctuating loads, which are difficult to detect. In addition, the surface hardness of the raceways, the operating temperature, and having LM blocks arranged directly behind one another will have a decisive impact on the service life. Taking these factors into account, the modified nominal life (L_{10m}) can be calculated according to the following formulas (3) and (4).

Modified factor α

$$\alpha = \frac{f_H \cdot f_T \cdot f_C}{f_W}$$

α : Modified factor

f_H : Hardness factor

f_T : Temperature factor

f_C : Contact factor

f_W : Load factor

*See the general catalog for details of the hardness factor, temperature factor, contact factor, and load factor.

Modified nominal life L_{10m} :

- LM Guide with balls (Formula 3)

$$L_{10m} = \left(\alpha \times \frac{C}{P_c} \right)^3 \times 50$$

L_{10m} : Modified nominal life (km)

C: Basic dynamic load rating (N)

P_c : Calculated load (N)

- LM Guide with rollers (Formula 4)

$$L_{10m} = \left(\alpha \times \frac{C}{P_c} \right)^{\frac{10}{3}} \times 100$$

Once the nominal life (L_{10}) has been obtained, the service life time can be obtained using the following formula if the stroke length and the number of cycles are constant.

$$L_h = \frac{L_{10} \times 10^6}{2 \times l_s \times n_1 \times 60}$$

L_h : Service life time (h)

l_s : Stroke length (mm)

n_1 : Cycles per minute (min^{-1})

Handling

- (1) Please use at least two people to move any product weighing 20 kg or more, or use a cart or another method of conveyance. Otherwise, it may cause injury or damage the unit.
- (2) Do not disassemble the parts. This may result in loss of functionality.
- (3) Tilting an LM block or LM rail may cause it to fall by its own weight.
- (4) Take care not to drop or strike the LM Guide. Otherwise, it may cause injury or damage the unit. Even if there is no outward indication of damage, a sudden impact could prevent the unit from functioning properly.
- (5) When installing the LM Guide, be sure not to remove the LM block from the LM rail.
- (6) Placing a hand inside the LM rail mounting hole may lead to the hand being caught between the block and rail and cause injury.
- (7) Wear appropriate safety gear, such as protective gloves and safety shoes, when handling the product.

Precautions on Use

- (1) Prevent foreign materials, such as cutting chips or coolant, from entering the product. Failure to do so could damage the product.
- (2) Prevent foreign materials, such as cutting chips, coolant, corrosive solvents, or water from getting in the product by using a bellows or cover when the product is used in an environment where such a thing is likely.
- (3) Do not use this product if the external temperature exceeds 80°C. If used in excess of this temperature, there is a risk that the resin and rubber parts may deform or become damaged (except the heat-resistant type).
- (4) If foreign materials such as cutting chips adhere to the product, replenish the lubricant after cleaning the product.
- (5) Very small strokes can inhibit the formation of an oil film between the raceways and the area of contact for the rollers, resulting in fretting. Therefore, be sure to use a type of grease with high fretting resistance properties if the stroke will be small. We recommend periodically allowing the LM block to stroke a distance roughly equal to its length to help ensure that a film forms between the raceways and rollers.
- (6) Do not forcibly drive a pin, key, or any other positioning device into the product. This could create indentations on the raceway and impair the product's function.
- (7) If the operation requires the LM block to be removed from the LM rail, please use a removing/mounting jig. (The removing/mounting jig is not provided as standard. To obtain one, contact THK.)
- (8) When using a removing/mounting jig, align the ends of the LM rail and the jig and mount the block when the jig and rail are parallel.
- (9) Mounting the block while it is tilted can lead to contamination by foreign materials, damage to internal components, or dropped rollers.
- (10) Inserting and using the LM block on the LM rail while rollers are missing could lead to premature failure of the product.
- (11) If any rollers fall out of the LM block, contact THK. Do not use the product in that condition.
- (12) If the LM Guide breaks due to an accident or another cause, the LM block may become dislodged from the LM rail and fall. For the safe use of these products, take precautions such as adding a mechanism to prevent blocks from falling.
- (13) For bolt length, select a length that will leave a clearance at the bolt tip in relation to the effective tap depth.
- (14) If the mounting material lacks sufficient rigidity or accuracy, the bearing load may be focused in one area, and bearing functionality will dramatically decrease. Therefore, carefully consider the rigidity and accuracy of the housing and base, and the strength of the securing bolts.
- (15) If you will be removing the LM block from the LM rail and then replacing the block, an LM block mounting/removing jig that facilitates such installation is available. Contact THK for details.

Lubrication

- (1) Thoroughly wipe off anti-rust oil and feed lubricant before using the product.
- (2) Do not mix different lubricants. Even grease containing the same type of thickening agent may, if mixed, interact negatively due to disparate additives or other ingredients.
- (3) When using the product in locations exposed to constant vibrations or in special environments such as in clean rooms, vacuums, and low/high temperatures, use a lubricant suitable for its use/environment.
- (4) When lubricating products that do not feature a grease nipple or oil hole, directly coat the raceways with lubricant and perform several warm-up strokes to ensure that the grease permeates the interior.
- (5) Grease viscosity can vary depending on the temperature. Please keep in mind that the LM Guide's sliding resistance may be affected by changes in viscosity.
- (6) After lubrication, the sliding resistance of the LM Guide may increase due to the stirring resistance of the grease. Be sure to perform a warm-up operation and allow the grease to break in sufficiently before operating the machinery.
- (7) Excess grease may spatter after lubrication. Wipe off spattered grease as necessary.
- (8) Grease deteriorates over time, which decreases the lubricity, so perform regular grease inspections and replenish grease based on frequency of use.
- (9) How often grease should be replenished varies depending on the usage conditions and environment. We recommend greasing the system approximately every 100 km traveled (3 to 6 months). The final greasing interval/amount should be set at the actual machine.
- (10) The lubricant may not reach the raceway if the LM Guide is not installed in a horizontal orientation.
- (11) When adopting oil lubrication, the lubricant may not be distributed throughout the LM system depending on the mounting orientation of the LM block. Contact THK for details.

Storage

When storing the LM Guide, pack it as designated by THK and store it indoors in a horizontal position away from high or low temperatures and high humidity.

Please note that if the product has been kept in storage for an extended period, the lubricant inside may have deteriorated. Please ensure that you replenish the lubricant before using.

Disposal

The product should be treated as industrial waste and disposed of appropriately.

Recommended Products

Caged Roller LM Guide

SRN

- Ultra-high rigidity
- Smaller product height, thinner, and lower center of gravity compared to the Model SRG
- Long-term maintenance-free operation

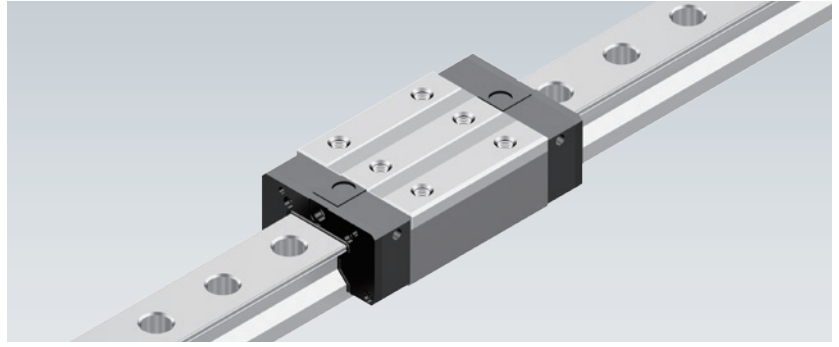

Caged Roller LM Guide SRG

●“LM Guide” and “” are registered trademarks of THK CO., LTD.

- The actual products may differ from the pictures and photographs in this catalog.
- Outward appearances and specifications are subject to change without notice for the purpose of improvement. Please consult with THK before using.
- Although great care has been taken in the production of this catalog, THK will not take any responsibility for damage resulting from typographical errors or omissions.
- For exports of our products and technologies and sales for export, our basic policy is to comply with the Foreign Exchange and Foreign Trade Act and other laws and regulations. Please consult us in advance if you want to export our products by the piece.

All rights reserved

THK CO., LTD.

Headquarters 2-12-10 Shibaura, Minato-ku, Tokyo 108-8506 Japan

International Sales Department Phone: +81-3-5730-3860

www.thk.com