

## Calculating the Applied Load

The LM Guide is capable of receiving loads and moments in all directions that are generated due to the mounting orientation, alignment, gravity center position of a traveling object, thrust position and cutting resistance.

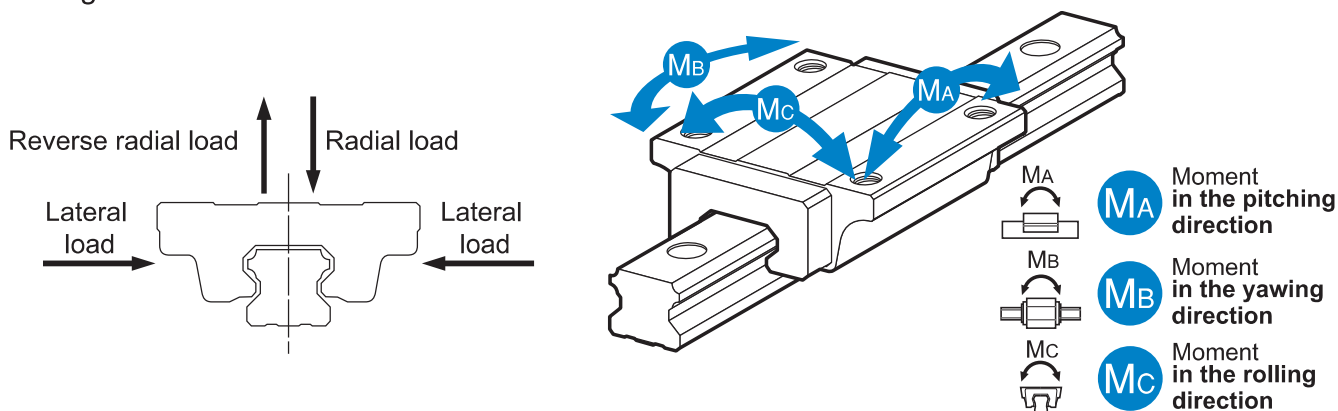

Fig.1 Directions of the Loads Applied on the LM Guide

## Calculating an Applied Load

### [Single-Axis Use]

#### ● Moment Equivalence

When the installation space for the LM Guide is limited, you may have to use only one LM block, or double LM blocks closely contacting with each other. In such a setting, the load distribution is not uniform and, as a result, an excessive load is applied in localized areas (i.e., both ends) as shown in Fig.2. Continued use under such conditions may result in flaking in those areas, consequently shortening the service life. In such a case, calculate the actual load by multiplying the moment value by any one of the equivalent-moment factors specified in Table1 to Table6.

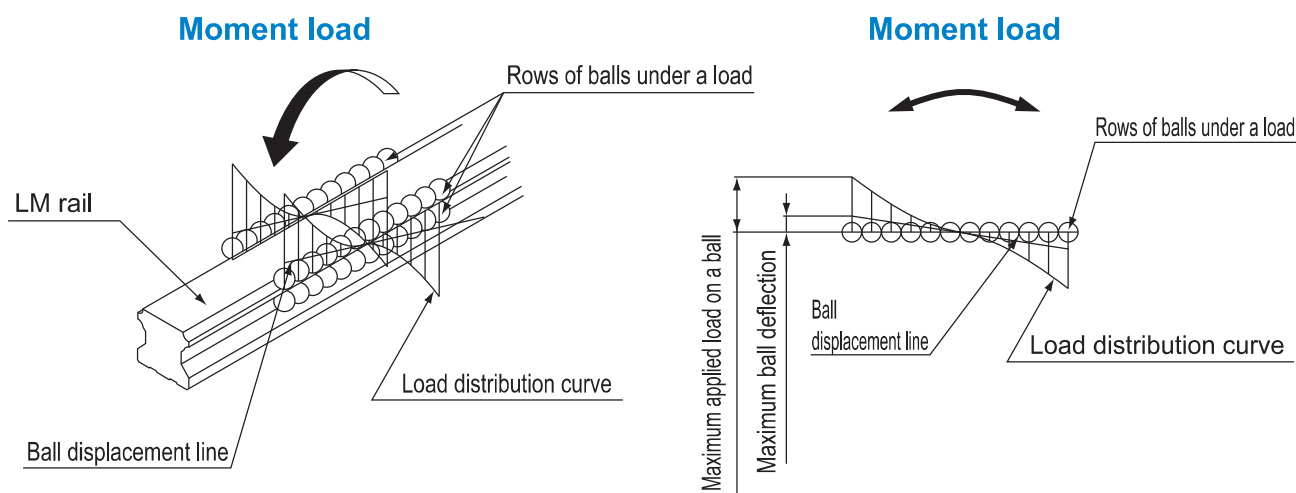

Fig.2 Ball Load when a Moment is Applied

An equivalent-load equation applicable when a moment acts on an LM Guide is shown below.

$$P = K \cdot M$$

P : Equivalent load per LM Guide (N)

K : Equivalent moment factor

M : Applied moment (N·mm)

### ● Equivalent Factor

Since the rated load is equivalent to the permissible moment, the equivalent factor to be multiplied when equalizing the  $M_A$ ,  $M_B$  and  $M_C$  moments to the applied load per block is obtained by dividing the rated loads in the corresponding directions.

With those models other than 4-way equal load types, however, the load ratings in the 4 directions differ from each other. Therefore, the equivalent factor values for the  $M_A$  and  $M_C$  moments also differ depending on whether the direction is radial or reverse radial.

### ■ Equivalent Factors for the $M_A$ Moment

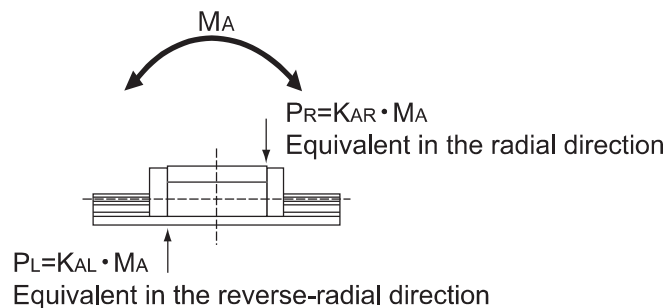

Fig.3 Equivalent Factors for the  $M_A$  Moment

Equivalent factors for the  $M_A$  Moment

Equivalent factor	in the radial direction	$K_{AR} = \frac{C_0}{M_A}$
	in the reverse radial direction	$K_{AL} = \frac{C_{0L}}{M_A}$

$$\frac{C_0}{K_{AR} \cdot M_A} = \frac{C_{0L}}{K_{AL} \cdot M_A} = 1$$

### ■ Equivalent Factors for the $M_B$ Moment

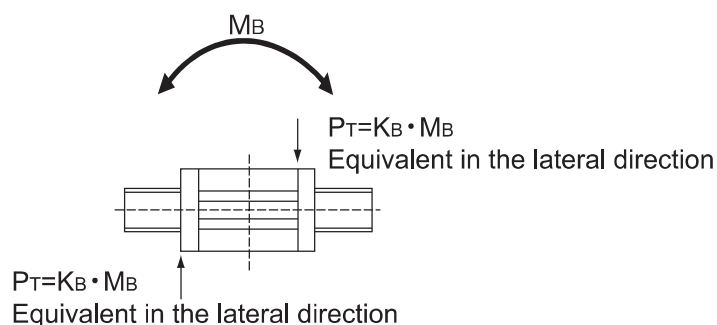

Fig.4 Equivalent Factors for the  $M_B$  Moment

Equivalent factors for the  $M_B$  Moment

Equivalent factor in the lateral directions	$K_B = \frac{C_{0T}}{M_B}$
---	----------------------------

$$\frac{C_{0T}}{K_B \cdot M_B} = 1$$

## ■ Equivalent Factors for the $M_c$ Moment

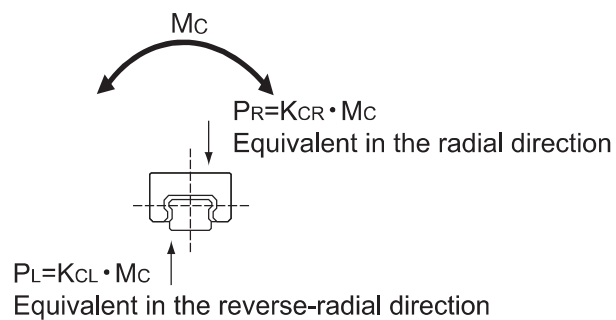

Fig.5 Equivalent Factors for the  $M_c$  Moment

Equivalent factors for the  $M_c$  Moment

Equivalent factor in the radial direction	$K_{CR} = \frac{C_0}{M_c}$
Equivalent factor in the reverse radial direction	$K_{CL} = \frac{C_{0L}}{M_c}$

$$\frac{C_0}{K_{CR} \cdot M_c} = \frac{C_{0L}}{K_{CL} \cdot M_c} = 1$$

$C_0$	: Basic static load rating (radial direction)	(N)
$C_{0L}$	: Basic static load rating (reverse radial direction)	(N)
$C_{0T}$	: Basic static load rating (lateral direction)	(N)
$P_R$	: Calculated load (radial direction)	(N)
$P_L$	: Calculated load (reverse radial direction)	(N)
$P_T$	: Calculated load (lateral direction)	(N)

## Point of Selection

## Calculating the Applied Load

Table1 Equivalent Factors (Models SHS, SSR, SVR, SVS, SHW and SRS)

Model No.		Equivalent factor							
		$K_{AR1}$	$K_{AL1}$	$K_{AR2}$	$K_{AL2}$	$K_{B1}$	$K_{B2}$	$K_{CR}$	$K_{CL}$
SHS	15	$1.38 \times 10^{-1}$		$2.69 \times 10^{-2}$		$1.38 \times 10^{-1}$	$2.69 \times 10^{-2}$	$1.50 \times 10^{-1}$	
	15L	$1.07 \times 10^{-1}$		$2.22 \times 10^{-2}$		$1.07 \times 10^{-1}$	$2.22 \times 10^{-2}$	$1.50 \times 10^{-1}$	
	20	$1.15 \times 10^{-1}$		$2.18 \times 10^{-2}$		$1.15 \times 10^{-1}$	$2.18 \times 10^{-2}$	$1.06 \times 10^{-1}$	
	20L	$8.85 \times 10^{-2}$		$1.79 \times 10^{-2}$		$8.85 \times 10^{-2}$	$1.79 \times 10^{-2}$	$1.06 \times 10^{-1}$	
	25	$9.25 \times 10^{-2}$		$1.90 \times 10^{-2}$		$9.25 \times 10^{-2}$	$1.90 \times 10^{-2}$	$9.29 \times 10^{-2}$	
	25L	$7.62 \times 10^{-2}$		$1.62 \times 10^{-2}$		$7.62 \times 10^{-2}$	$1.62 \times 10^{-2}$	$9.29 \times 10^{-2}$	
	30	$8.47 \times 10^{-2}$		$1.63 \times 10^{-2}$		$8.47 \times 10^{-2}$	$1.63 \times 10^{-2}$	$7.69 \times 10^{-2}$	
	30L	$6.52 \times 10^{-2}$		$1.34 \times 10^{-2}$		$6.52 \times 10^{-2}$	$1.34 \times 10^{-2}$	$7.69 \times 10^{-2}$	
	35	$6.95 \times 10^{-2}$		$1.43 \times 10^{-2}$		$6.95 \times 10^{-2}$	$1.43 \times 10^{-2}$	$6.29 \times 10^{-2}$	
	35L	$5.43 \times 10^{-2}$		$1.16 \times 10^{-2}$		$5.43 \times 10^{-2}$	$1.16 \times 10^{-2}$	$6.29 \times 10^{-2}$	
	45	$6.13 \times 10^{-2}$		$1.24 \times 10^{-2}$		$6.13 \times 10^{-2}$	$1.24 \times 10^{-2}$	$4.69 \times 10^{-2}$	
	45L	$4.79 \times 10^{-2}$		$1.02 \times 10^{-2}$		$4.79 \times 10^{-2}$	$1.02 \times 10^{-2}$	$4.69 \times 10^{-2}$	
	55	$4.97 \times 10^{-2}$		$1.02 \times 10^{-2}$		$4.97 \times 10^{-2}$	$1.02 \times 10^{-2}$	$4.02 \times 10^{-2}$	
	55L	$3.88 \times 10^{-2}$		$8.30 \times 10^{-3}$		$3.88 \times 10^{-2}$	$8.30 \times 10^{-3}$	$4.02 \times 10^{-2}$	
	65	$3.87 \times 10^{-2}$		$7.91 \times 10^{-3}$		$3.87 \times 10^{-2}$	$7.91 \times 10^{-3}$	$3.40 \times 10^{-2}$	
	65L	$3.06 \times 10^{-2}$		$6.51 \times 10^{-3}$		$3.06 \times 10^{-2}$	$6.51 \times 10^{-3}$	$3.40 \times 10^{-2}$	
SSR	15XW(XTB)	$2.08 \times 10^{-1}$	$1.04 \times 10^{-1}$	$3.75 \times 10^{-2}$	$1.87 \times 10^{-2}$	$1.46 \times 10^{-1}$	$2.59 \times 10^{-2}$	$1.71 \times 10^{-1}$	$8.57 \times 10^{-2}$
	15XV(XSB)	$3.19 \times 10^{-1}$	$1.60 \times 10^{-1}$	$5.03 \times 10^{-2}$	$2.51 \times 10^{-2}$	$2.20 \times 10^{-1}$	$3.41 \times 10^{-2}$	$1.71 \times 10^{-1}$	$8.57 \times 10^{-2}$
	20XW(XTB)	$1.69 \times 10^{-1}$	$8.46 \times 10^{-2}$	$3.23 \times 10^{-2}$	$1.62 \times 10^{-2}$	$1.19 \times 10^{-1}$	$2.25 \times 10^{-2}$	$1.29 \times 10^{-1}$	$6.44 \times 10^{-2}$
	20XV(XSB)	$2.75 \times 10^{-1}$	$1.37 \times 10^{-1}$	$4.28 \times 10^{-2}$	$2.14 \times 10^{-2}$	$1.89 \times 10^{-1}$	$2.89 \times 10^{-2}$	$1.29 \times 10^{-1}$	$6.44 \times 10^{-2}$
	25XW(XTB)	$1.41 \times 10^{-1}$	$7.05 \times 10^{-2}$	$2.56 \times 10^{-2}$	$1.28 \times 10^{-2}$	$9.86 \times 10^{-2}$	$1.77 \times 10^{-2}$	$1.10 \times 10^{-1}$	$5.51 \times 10^{-2}$
	25XV(XSB)	$2.15 \times 10^{-1}$	$1.08 \times 10^{-1}$	$3.40 \times 10^{-2}$	$1.70 \times 10^{-2}$	$1.48 \times 10^{-1}$	$2.31 \times 10^{-2}$	$1.10 \times 10^{-1}$	$5.51 \times 10^{-2}$
	30XW(XTB)	$1.18 \times 10^{-1}$	$5.91 \times 10^{-2}$	$2.19 \times 10^{-2}$	$1.10 \times 10^{-2}$	$8.26 \times 10^{-2}$	$1.52 \times 10^{-2}$	$9.22 \times 10^{-2}$	$4.61 \times 10^{-2}$
	30XV(XSB)	$1.85 \times 10^{-1}$	$9.24 \times 10^{-2}$	$4.69 \times 10^{-2}$	$2.34 \times 10^{-2}$	$1.27 \times 10^{-1}$	$3.19 \times 10^{-2}$	$9.16 \times 10^{-2}$	$4.58 \times 10^{-2}$
	35XW(XTB)	$1.01 \times 10^{-1}$	$5.03 \times 10^{-2}$	$1.92 \times 10^{-2}$	$9.60 \times 10^{-3}$	$7.04 \times 10^{-2}$	$1.33 \times 10^{-2}$	$7.64 \times 10^{-2}$	$3.82 \times 10^{-2}$
	35XV(XSB)	$1.58 \times 10^{-1}$	$7.91 \times 10^{-2}$	$4.04 \times 10^{-2}$	$2.02 \times 10^{-2}$	$1.09 \times 10^{-1}$	$2.75 \times 10^{-2}$	$7.59 \times 10^{-2}$	$3.80 \times 10^{-2}$
SVR	25	$1.13 \times 10^{-1}$	$7.28 \times 10^{-2}$	$2.25 \times 10^{-2}$	$1.45 \times 10^{-2}$	$7.14 \times 10^{-2}$	$1.43 \times 10^{-2}$	$9.59 \times 10^{-2}$	$6.17 \times 10^{-2}$
	25L	$9.14 \times 10^{-2}$	$5.88 \times 10^{-2}$	$1.85 \times 10^{-2}$	$1.19 \times 10^{-2}$	$5.80 \times 10^{-2}$	$1.17 \times 10^{-2}$	$9.59 \times 10^{-2}$	$6.17 \times 10^{-2}$
	30	$1.01 \times 10^{-1}$	$6.50 \times 10^{-2}$	$1.89 \times 10^{-2}$	$1.21 \times 10^{-2}$	$6.36 \times 10^{-2}$	$1.19 \times 10^{-2}$	$8.45 \times 10^{-2}$	$5.43 \times 10^{-2}$
	30L	$7.56 \times 10^{-2}$	$4.86 \times 10^{-2}$	$1.57 \times 10^{-2}$	$1.01 \times 10^{-2}$	$4.79 \times 10^{-2}$	$1.00 \times 10^{-2}$	$8.45 \times 10^{-2}$	$5.43 \times 10^{-2}$
	35	$9.19 \times 10^{-2}$	$5.91 \times 10^{-2}$	$1.68 \times 10^{-2}$	$1.08 \times 10^{-2}$	$5.77 \times 10^{-2}$	$1.06 \times 10^{-2}$	$7.08 \times 10^{-2}$	$4.55 \times 10^{-2}$
	35L	$6.80 \times 10^{-2}$	$4.37 \times 10^{-2}$	$1.39 \times 10^{-2}$	$8.97 \times 10^{-3}$	$4.31 \times 10^{-2}$	$8.86 \times 10^{-3}$	$7.08 \times 10^{-2}$	$4.55 \times 10^{-2}$
	45	$6.73 \times 10^{-2}$	$4.33 \times 10^{-2}$	$1.35 \times 10^{-2}$	$8.71 \times 10^{-3}$	$4.25 \times 10^{-2}$	$8.59 \times 10^{-3}$	$5.32 \times 10^{-2}$	$3.42 \times 10^{-2}$
	45L	$5.40 \times 10^{-2}$	$3.47 \times 10^{-2}$	$1.10 \times 10^{-2}$	$7.09 \times 10^{-3}$	$3.41 \times 10^{-2}$	$6.97 \times 10^{-3}$	$5.30 \times 10^{-2}$	$3.41 \times 10^{-2}$
	55	$5.89 \times 10^{-2}$	$3.79 \times 10^{-2}$	$1.14 \times 10^{-2}$	$7.35 \times 10^{-3}$	$3.72 \times 10^{-2}$	$7.24 \times 10^{-3}$	$4.63 \times 10^{-2}$	$2.98 \times 10^{-2}$
	55L	$4.55 \times 10^{-2}$	$2.92 \times 10^{-2}$	$9.45 \times 10^{-3}$	$6.08 \times 10^{-3}$	$2.89 \times 10^{-2}$	$6.02 \times 10^{-3}$	$4.63 \times 10^{-2}$	$2.98 \times 10^{-2}$
	65	$4.85 \times 10^{-2}$	$3.12 \times 10^{-2}$	$1.01 \times 10^{-2}$	$6.48 \times 10^{-3}$	$3.06 \times 10^{-2}$	$6.40 \times 10^{-3}$	$3.91 \times 10^{-2}$	$2.51 \times 10^{-2}$
	65L	$3.58 \times 10^{-2}$	$2.30 \times 10^{-2}$	$7.73 \times 10^{-3}$	$4.97 \times 10^{-3}$	$2.28 \times 10^{-2}$	$4.93 \times 10^{-3}$	$3.91 \times 10^{-2}$	$2.51 \times 10^{-2}$

Model No.		Equivalent factor							
		$K_{AR1}$	$K_{AL1}$	$K_{AR2}$	$K_{AL2}$	$K_{B1}$	$K_{B2}$	$K_{CR}$	$K_{CL}$
SVS	25	$1.09 \times 10^{-1}$	$9.14 \times 10^{-2}$	$2.17 \times 10^{-2}$	$1.82 \times 10^{-2}$	$1.00 \times 10^{-1}$	$2.00 \times 10^{-2}$	$9.95 \times 10^{-2}$	$8.35 \times 10^{-2}$
	25L	$8.82 \times 10^{-2}$	$7.40 \times 10^{-2}$	$1.78 \times 10^{-2}$	$1.50 \times 10^{-2}$	$8.13 \times 10^{-2}$	$1.64 \times 10^{-2}$	$9.95 \times 10^{-2}$	$8.35 \times 10^{-2}$
	30	$9.71 \times 10^{-2}$	$8.15 \times 10^{-2}$	$1.82 \times 10^{-2}$	$1.52 \times 10^{-2}$	$8.95 \times 10^{-2}$	$1.67 \times 10^{-2}$	$8.78 \times 10^{-2}$	$7.37 \times 10^{-2}$
	30L	$7.29 \times 10^{-2}$	$6.11 \times 10^{-2}$	$1.51 \times 10^{-2}$	$1.27 \times 10^{-2}$	$6.72 \times 10^{-2}$	$1.39 \times 10^{-2}$	$8.78 \times 10^{-2}$	$7.37 \times 10^{-2}$
	35	$8.84 \times 10^{-2}$	$7.42 \times 10^{-2}$	$1.61 \times 10^{-2}$	$1.35 \times 10^{-2}$	$8.14 \times 10^{-2}$	$1.48 \times 10^{-2}$	$7.36 \times 10^{-2}$	$6.17 \times 10^{-2}$
	35L	$6.56 \times 10^{-2}$	$5.50 \times 10^{-2}$	$1.34 \times 10^{-2}$	$1.13 \times 10^{-2}$	$6.04 \times 10^{-2}$	$1.24 \times 10^{-2}$	$7.36 \times 10^{-2}$	$6.17 \times 10^{-2}$
	45	$6.48 \times 10^{-2}$	$5.44 \times 10^{-2}$	$1.30 \times 10^{-2}$	$1.09 \times 10^{-2}$	$5.98 \times 10^{-2}$	$1.20 \times 10^{-2}$	$5.45 \times 10^{-2}$	$4.57 \times 10^{-2}$
	45L	$5.22 \times 10^{-2}$	$4.38 \times 10^{-2}$	$1.07 \times 10^{-2}$	$8.94 \times 10^{-3}$	$4.81 \times 10^{-2}$	$9.81 \times 10^{-3}$	$5.44 \times 10^{-2}$	$4.56 \times 10^{-2}$
	55	$5.67 \times 10^{-2}$	$4.76 \times 10^{-2}$	$1.10 \times 10^{-2}$	$9.24 \times 10^{-3}$	$5.23 \times 10^{-2}$	$1.01 \times 10^{-2}$	$4.78 \times 10^{-2}$	$4.01 \times 10^{-2}$
	55L	$4.39 \times 10^{-2}$	$3.68 \times 10^{-2}$	$9.12 \times 10^{-3}$	$7.65 \times 10^{-3}$	$4.05 \times 10^{-2}$	$8.40 \times 10^{-3}$	$4.78 \times 10^{-2}$	$4.01 \times 10^{-2}$
	65	$4.67 \times 10^{-2}$	$3.92 \times 10^{-2}$	$9.72 \times 10^{-3}$	$8.15 \times 10^{-3}$	$4.30 \times 10^{-2}$	$8.95 \times 10^{-3}$	$4.04 \times 10^{-2}$	$3.39 \times 10^{-2}$
	65L	$3.46 \times 10^{-2}$	$2.90 \times 10^{-2}$	$7.46 \times 10^{-3}$	$6.26 \times 10^{-3}$	$3.19 \times 10^{-2}$	$6.88 \times 10^{-3}$	$4.04 \times 10^{-2}$	$3.39 \times 10^{-2}$
SHW	12	$2.48 \times 10^{-1}$		$4.69 \times 10^{-2}$		$2.48 \times 10^{-1}$	$4.69 \times 10^{-2}$	$1.40 \times 10^{-1}$	
	12HR	$1.70 \times 10^{-1}$		$3.52 \times 10^{-2}$		$1.70 \times 10^{-1}$	$3.52 \times 10^{-2}$	$1.40 \times 10^{-1}$	
	14	$1.92 \times 10^{-1}$		$3.80 \times 10^{-2}$		$1.92 \times 10^{-1}$	$3.80 \times 10^{-2}$	$9.93 \times 10^{-2}$	
	17	$1.72 \times 10^{-1}$		$3.41 \times 10^{-2}$		$1.72 \times 10^{-1}$	$3.41 \times 10^{-2}$	$6.21 \times 10^{-2}$	
	21	$1.59 \times 10^{-1}$		$2.95 \times 10^{-2}$		$1.59 \times 10^{-1}$	$2.95 \times 10^{-2}$	$5.57 \times 10^{-2}$	
	27	$1.21 \times 10^{-1}$		$2.39 \times 10^{-2}$		$1.21 \times 10^{-1}$	$2.39 \times 10^{-2}$	$4.99 \times 10^{-2}$	
	35	$8.15 \times 10^{-2}$		$1.64 \times 10^{-2}$		$8.15 \times 10^{-2}$	$1.64 \times 10^{-2}$	$3.02 \times 10^{-2}$	
50	$6.22 \times 10^{-2}$		$1.24 \times 10^{-2}$		$6.22 \times 10^{-2}$	$1.24 \times 10^{-2}$	$2.30 \times 10^{-2}$		
SRS	5M	$6.33 \times 10^{-1}$		$9.20 \times 10^{-2}$		$6.45 \times 10^{-1}$	$9.30 \times 10^{-2}$	$3.85 \times 10^{-1}$	
	5GM	$6.71 \times 10^{-1}$		$9.15 \times 10^{-2}$		$6.66 \times 10^{-1}$	$9.08 \times 10^{-2}$	$3.85 \times 10^{-1}$	
	5N	$5.23 \times 10^{-1}$		$7.87 \times 10^{-2}$		$5.32 \times 10^{-1}$	$7.99 \times 10^{-2}$	$3.86 \times 10^{-1}$	
	5GN	$5.25 \times 10^{-1}$		$7.97 \times 10^{-2}$		$5.33 \times 10^{-1}$	$8.12 \times 10^{-2}$	$3.84 \times 10^{-1}$	
	5WM	$4.48 \times 10^{-1}$		$7.30 \times 10^{-2}$		$4.56 \times 10^{-1}$	$7.40 \times 10^{-2}$	$1.96 \times 10^{-1}$	
	5WGM	$4.58 \times 10^{-1}$		$7.39 \times 10^{-2}$		$4.54 \times 10^{-1}$	$7.34 \times 10^{-2}$	$1.96 \times 10^{-1}$	
	5WN	$3.31 \times 10^{-1}$		$5.93 \times 10^{-2}$		$3.36 \times 10^{-1}$	$6.02 \times 10^{-2}$	$1.96 \times 10^{-1}$	
	5WGN	$3.31 \times 10^{-1}$		$5.97 \times 10^{-2}$		$3.35 \times 10^{-1}$	$6.05 \times 10^{-2}$	$1.96 \times 10^{-1}$	
	7S	$6.03 \times 10^{-1}$		$7.65 \times 10^{-2}$		$6.27 \times 10^{-1}$	$7.91 \times 10^{-2}$	$2.58 \times 10^{-1}$	
	7GS	$5.92 \times 10^{-1}$		$7.89 \times 10^{-2}$		$6.14 \times 10^{-1}$	$8.17 \times 10^{-2}$	$2.58 \times 10^{-1}$	
	7M	$4.19 \times 10^{-1}$		$6.76 \times 10^{-2}$		$4.18 \times 10^{-1}$	$6.94 \times 10^{-2}$	$2.58 \times 10^{-1}$	
	7GM	$4.27 \times 10^{-1}$		$6.04 \times 10^{-2}$		$4.43 \times 10^{-1}$	$6.23 \times 10^{-2}$	$2.34 \times 10^{-1}$	
	7N	$2.97 \times 10^{-1}$		$5.35 \times 10^{-2}$		$3.07 \times 10^{-1}$	$5.50 \times 10^{-2}$	$2.58 \times 10^{-1}$	
	7GN	$3.11 \times 10^{-1}$		$5.35 \times 10^{-2}$		$3.20 \times 10^{-1}$	$5.51 \times 10^{-2}$	$2.58 \times 10^{-1}$	
	7WS	$4.67 \times 10^{-1}$		$6.89 \times 10^{-2}$		$4.84 \times 10^{-1}$	$7.08 \times 10^{-2}$	$1.36 \times 10^{-1}$	
	7WGS	$5.23 \times 10^{-1}$		$6.75 \times 10^{-2}$		$5.43 \times 10^{-1}$	$6.95 \times 10^{-2}$	$1.36 \times 10^{-1}$	
	7WM	$3.01 \times 10^{-1}$		$5.32 \times 10^{-2}$		$3.00 \times 10^{-1}$	$5.46 \times 10^{-2}$	$1.36 \times 10^{-1}$	
	7WGM	$2.83 \times 10^{-1}$		$4.87 \times 10^{-2}$		$2.93 \times 10^{-1}$	$5.02 \times 10^{-2}$	$1.24 \times 10^{-1}$	
	7WN	$2.19 \times 10^{-1}$		$4.16 \times 10^{-2}$		$2.24 \times 10^{-1}$	$4.28 \times 10^{-2}$	$1.36 \times 10^{-1}$	
	7WGN	$2.20 \times 10^{-1}$		$4.17 \times 10^{-2}$		$2.27 \times 10^{-1}$	$4.31 \times 10^{-2}$	$1.36 \times 10^{-1}$	

$K_{AR1}$  : Equivalent factor in the  $M_A$  radial direction when one LM block is used  
 $K_{AL1}$  : Equivalent factor in the  $M_A$  reverse radial direction when one LM block is used  
 $K_{AR2}$  : Equivalent factor in the  $M_A$  radial direction when two LM blocks are used in close contact with each other  
 $K_{AL2}$  : Equivalent factor in the  $M_A$  reverse radial direction when two LM blocks are used in close contact with each other

$K_{B1}$  :  $M_B$  Equivalent factor when one LM block is used  
 $K_{B2}$  :  $M_B$  Equivalent factor when two LM blocks are used in close contact with each other  
 $K_{CR}$  : Equivalent factor in the  $M_C$  radial direction  
 $K_{CL}$  : Equivalent factor in the  $M_C$  reverse radial direction

## Point of Selection

## Calculating the Applied Load

Table2 Equivalent Factors (Models SRS, SCR, EPF and HSR)

Model No.		Equivalent factor							
		$K_{AR1}$	$K_{AL1}$	$K_{AR2}$	$K_{AL2}$	$K_{B1}$	$K_{B2}$	$K_{CR}$	$K_{CL}$
SRS	9XS	$4.86 \times 10^{-1}$		$6.89 \times 10^{-2}$		$5.04 \times 10^{-1}$	$7.11 \times 10^{-2}$		$2.17 \times 10^{-1}$
	9XGS	$5.37 \times 10^{-1}$		$6.77 \times 10^{-2}$		$5.57 \times 10^{-1}$	$7.00 \times 10^{-2}$		$2.17 \times 10^{-1}$
	9XM	$2.95 \times 10^{-1}$		$5.27 \times 10^{-2}$		$3.06 \times 10^{-1}$	$5.43 \times 10^{-2}$		$2.17 \times 10^{-1}$
	9XGM	$3.10 \times 10^{-1}$		$5.28 \times 10^{-2}$		$3.19 \times 10^{-1}$	$5.44 \times 10^{-2}$		$2.17 \times 10^{-1}$
	9XN	$2.13 \times 10^{-1}$		$4.12 \times 10^{-2}$		$2.19 \times 10^{-1}$	$4.23 \times 10^{-2}$		$2.17 \times 10^{-1}$
	9XGN	$2.18 \times 10^{-1}$		$4.14 \times 10^{-2}$		$2.24 \times 10^{-1}$	$4.27 \times 10^{-2}$		$2.17 \times 10^{-1}$
	9WS	$4.10 \times 10^{-1}$		$5.73 \times 10^{-2}$		$4.25 \times 10^{-1}$	$5.63 \times 10^{-2}$		$1.06 \times 10^{-1}$
	9WGS	$4.16 \times 10^{-1}$		$5.80 \times 10^{-2}$		$4.30 \times 10^{-1}$	$5.98 \times 10^{-2}$		$1.06 \times 10^{-1}$
	9WM	$2.37 \times 10^{-1}$		$4.25 \times 10^{-2}$		$2.44 \times 10^{-1}$	$4.37 \times 10^{-2}$		$1.06 \times 10^{-1}$
	9WGM	$2.41 \times 10^{-1}$		$4.80 \times 10^{-2}$		$2.41 \times 10^{-1}$	$4.13 \times 10^{-2}$		$1.06 \times 10^{-1}$
	9WN	$1.74 \times 10^{-1}$		$3.35 \times 10^{-2}$		$1.78 \times 10^{-1}$	$3.44 \times 10^{-2}$		$1.06 \times 10^{-1}$
	9WGN	$1.75 \times 10^{-1}$		$3.38 \times 10^{-2}$		$1.73 \times 10^{-1}$	$3.32 \times 10^{-2}$		$1.06 \times 10^{-1}$
	12S	$4.55 \times 10^{-1}$		$5.60 \times 10^{-2}$		$4.55 \times 10^{-1}$	$5.60 \times 10^{-2}$		$1.52 \times 10^{-1}$
	12GS	$5.04 \times 10^{-1}$		$5.51 \times 10^{-2}$		$5.04 \times 10^{-1}$	$5.51 \times 10^{-2}$		$1.52 \times 10^{-1}$
	12M	$2.94 \times 10^{-1}$		$4.50 \times 10^{-2}$		$2.94 \times 10^{-1}$	$4.50 \times 10^{-2}$		$1.53 \times 10^{-1}$
	12GM	$2.93 \times 10^{-1}$		$4.49 \times 10^{-2}$		$2.93 \times 10^{-1}$	$4.49 \times 10^{-2}$		$1.53 \times 10^{-1}$
	12N	$1.86 \times 10^{-1}$		$3.51 \times 10^{-2}$		$1.86 \times 10^{-1}$	$3.51 \times 10^{-2}$		$1.53 \times 10^{-1}$
	12GN	$1.96 \times 10^{-1}$		$3.50 \times 10^{-2}$		$1.96 \times 10^{-1}$	$3.50 \times 10^{-2}$		$1.53 \times 10^{-1}$
	12WS	$3.22 \times 10^{-1}$		$5.00 \times 10^{-2}$		$3.22 \times 10^{-1}$	$5.00 \times 10^{-2}$		$7.97 \times 10^{-2}$
	12WGS	$3.32 \times 10^{-1}$		$5.07 \times 10^{-2}$		$3.32 \times 10^{-1}$	$5.07 \times 10^{-2}$		$7.97 \times 10^{-2}$
	12WM	$2.00 \times 10^{-1}$		$3.69 \times 10^{-2}$		$2.00 \times 10^{-1}$	$3.69 \times 10^{-2}$		$7.97 \times 10^{-2}$
	12WGM	$2.07 \times 10^{-1}$		$3.64 \times 10^{-2}$		$2.07 \times 10^{-1}$	$3.64 \times 10^{-2}$		$7.96 \times 10^{-2}$
	12WN	$1.44 \times 10^{-1}$		$2.83 \times 10^{-2}$		$1.44 \times 10^{-1}$	$2.83 \times 10^{-2}$		$7.97 \times 10^{-2}$
	12WGN	$1.46 \times 10^{-1}$		$2.85 \times 10^{-2}$		$1.46 \times 10^{-1}$	$2.85 \times 10^{-2}$		$7.95 \times 10^{-2}$
	15S	$3.56 \times 10^{-1}$		$4.38 \times 10^{-2}$		$3.56 \times 10^{-1}$	$4.38 \times 10^{-2}$		$1.41 \times 10^{-1}$
	15GS	$3.37 \times 10^{-1}$		$4.57 \times 10^{-2}$		$3.37 \times 10^{-1}$	$4.57 \times 10^{-2}$		$1.41 \times 10^{-1}$
	15M	$2.17 \times 10^{-1}$		$3.69 \times 10^{-2}$		$2.17 \times 10^{-1}$	$3.69 \times 10^{-2}$		$1.41 \times 10^{-1}$
	15GM	$2.31 \times 10^{-1}$		$3.61 \times 10^{-2}$		$2.31 \times 10^{-1}$	$3.61 \times 10^{-2}$		$1.41 \times 10^{-1}$
	15N	$1.43 \times 10^{-1}$		$2.73 \times 10^{-2}$		$1.43 \times 10^{-1}$	$2.73 \times 10^{-2}$		$1.41 \times 10^{-1}$
	15GN	$1.45 \times 10^{-1}$		$2.75 \times 10^{-2}$		$1.45 \times 10^{-1}$	$2.75 \times 10^{-2}$		$1.41 \times 10^{-1}$
	15WS	$2.34 \times 10^{-1}$		$3.76 \times 10^{-2}$		$2.34 \times 10^{-1}$	$3.76 \times 10^{-2}$		$4.83 \times 10^{-2}$
	15WGS	$2.34 \times 10^{-1}$		$3.81 \times 10^{-2}$		$2.34 \times 10^{-1}$	$3.81 \times 10^{-2}$		$4.84 \times 10^{-2}$
	15WM	$1.67 \times 10^{-1}$		$2.94 \times 10^{-2}$		$1.67 \times 10^{-1}$	$2.94 \times 10^{-2}$		$4.83 \times 10^{-2}$
	15WGM	$1.63 \times 10^{-1}$		$2.93 \times 10^{-2}$		$1.63 \times 10^{-1}$	$2.93 \times 10^{-2}$		$4.83 \times 10^{-2}$
	15WN	$1.13 \times 10^{-1}$		$2.27 \times 10^{-2}$		$1.13 \times 10^{-1}$	$2.27 \times 10^{-2}$		$4.83 \times 10^{-2}$
	15WGN	$1.15 \times 10^{-1}$		$2.28 \times 10^{-2}$		$1.15 \times 10^{-1}$	$2.28 \times 10^{-2}$		$4.83 \times 10^{-2}$
	20M	$1.80 \times 10^{-1}$		$3.30 \times 10^{-2}$		$1.86 \times 10^{-1}$	$3.41 \times 10^{-2}$		$9.34 \times 10^{-2}$
	20GM	$2.10 \times 10^{-1}$		$3.88 \times 10^{-2}$		$2.10 \times 10^{-1}$	$3.87 \times 10^{-2}$		$1.03 \times 10^{-1}$
	25M	$1.14 \times 10^{-1}$		$2.17 \times 10^{-2}$		$1.14 \times 10^{-1}$	$2.17 \times 10^{-2}$		$8.13 \times 10^{-2}$
	25GM	$1.23 \times 10^{-1}$		$2.32 \times 10^{-2}$		$1.23 \times 10^{-1}$	$2.32 \times 10^{-2}$		$8.75 \times 10^{-2}$

Model No.		Equivalent factor							
		$K_{AR1}$	$K_{AL1}$	$K_{AR2}$	$K_{AL2}$	$K_{B1}$	$K_{B2}$	$K_{CR}$	$K_{CL}$
SCR	15S	$1.38 \times 10^{-1}$		$2.69 \times 10^{-2}$		$1.38 \times 10^{-1}$			—
	20S	$1.15 \times 10^{-1}$		$2.18 \times 10^{-2}$		$1.15 \times 10^{-1}$			—
	20	$8.85 \times 10^{-2}$		$1.79 \times 10^{-2}$		$8.85 \times 10^{-2}$			—
	25	$9.25 \times 10^{-2}$		$1.90 \times 10^{-2}$		$9.25 \times 10^{-2}$	$1.90 \times 10^{-2}$		—
	30	$8.47 \times 10^{-2}$		$1.63 \times 10^{-2}$		$8.47 \times 10^{-2}$	$1.63 \times 10^{-2}$		—
	35	$6.95 \times 10^{-2}$		$1.43 \times 10^{-2}$		$6.95 \times 10^{-2}$	$1.43 \times 10^{-2}$		—
	45	$6.13 \times 10^{-2}$		$1.24 \times 10^{-2}$		$6.13 \times 10^{-2}$	$1.24 \times 10^{-2}$		—
	65	$3.87 \times 10^{-2}$		$7.91 \times 10^{-3}$		$3.87 \times 10^{-2}$	$7.91 \times 10^{-3}$		—
EPF	7M	$3.55 \times 10^{-1}$		—		$3.55 \times 10^{-1}$			$2.86 \times 10^{-1}$
	9M	$3.10 \times 10^{-1}$		—		$3.10 \times 10^{-1}$			$2.22 \times 10^{-1}$
	12M	$2.68 \times 10^{-1}$		—		$2.68 \times 10^{-1}$			$1.67 \times 10^{-1}$
	15M	$2.00 \times 10^{-1}$		—		$2.00 \times 10^{-1}$			$1.34 \times 10^{-1}$
HSR	8	$4.39 \times 10^{-1}$		$6.75 \times 10^{-2}$		$4.39 \times 10^{-1}$	$6.75 \times 10^{-2}$		$2.97 \times 10^{-1}$
	10	$3.09 \times 10^{-1}$		$5.33 \times 10^{-2}$		$3.09 \times 10^{-1}$	$5.33 \times 10^{-2}$		$2.35 \times 10^{-1}$
	12	$2.08 \times 10^{-1}$		$3.74 \times 10^{-2}$		$2.08 \times 10^{-1}$	$3.74 \times 10^{-2}$		$1.91 \times 10^{-1}$
	15	$1.66 \times 10^{-1}$		$2.98 \times 10^{-2}$		$1.66 \times 10^{-1}$	$2.98 \times 10^{-2}$		$1.57 \times 10^{-1}$
	15L	$1.18 \times 10^{-1}$		$2.33 \times 10^{-2}$		$1.18 \times 10^{-1}$	$2.33 \times 10^{-2}$		$1.57 \times 10^{-1}$
	20	$1.26 \times 10^{-1}$		$2.28 \times 10^{-2}$		$1.26 \times 10^{-1}$	$2.28 \times 10^{-2}$		$1.17 \times 10^{-1}$
	20L	$9.88 \times 10^{-2}$		$1.92 \times 10^{-2}$		$9.88 \times 10^{-2}$	$1.92 \times 10^{-2}$		$1.17 \times 10^{-1}$
	25	$1.12 \times 10^{-1}$		$2.02 \times 10^{-2}$		$1.12 \times 10^{-1}$	$2.02 \times 10^{-2}$		$9.96 \times 10^{-2}$
	25L	$8.23 \times 10^{-2}$		$1.70 \times 10^{-2}$		$8.23 \times 10^{-2}$	$1.70 \times 10^{-2}$		$9.96 \times 10^{-2}$
	30	$8.97 \times 10^{-2}$		$1.73 \times 10^{-2}$		$8.97 \times 10^{-2}$	$1.73 \times 10^{-2}$		$8.24 \times 10^{-2}$
	30L	$7.05 \times 10^{-2}$		$1.44 \times 10^{-2}$		$7.05 \times 10^{-2}$	$1.44 \times 10^{-2}$		$8.24 \times 10^{-2}$
	35	$7.85 \times 10^{-2}$		$1.56 \times 10^{-2}$		$7.85 \times 10^{-2}$	$1.56 \times 10^{-2}$		$6.69 \times 10^{-2}$
	35L	$6.17 \times 10^{-2}$		$1.29 \times 10^{-2}$		$6.17 \times 10^{-2}$	$1.29 \times 10^{-2}$		$6.69 \times 10^{-2}$
	45	$6.73 \times 10^{-2}$		$1.21 \times 10^{-2}$		$6.73 \times 10^{-2}$	$1.21 \times 10^{-2}$		$5.20 \times 10^{-2}$
	45L	$5.22 \times 10^{-2}$		$1.01 \times 10^{-2}$		$5.22 \times 10^{-2}$	$1.01 \times 10^{-2}$		$5.20 \times 10^{-2}$
	55	$5.61 \times 10^{-2}$		$1.03 \times 10^{-2}$		$5.61 \times 10^{-2}$	$1.03 \times 10^{-2}$		$4.26 \times 10^{-2}$
	55L	$4.35 \times 10^{-2}$		$8.56 \times 10^{-3}$		$4.35 \times 10^{-2}$	$8.56 \times 10^{-3}$		$4.26 \times 10^{-2}$
	65	$4.49 \times 10^{-2}$		$9.13 \times 10^{-3}$		$4.49 \times 10^{-2}$	$9.13 \times 10^{-3}$		$3.68 \times 10^{-2}$
	65L	$3.29 \times 10^{-2}$		$7.08 \times 10^{-3}$		$3.29 \times 10^{-2}$	$7.08 \times 10^{-3}$		$3.68 \times 10^{-2}$
	85	$3.49 \times 10^{-2}$		$6.94 \times 10^{-3}$		$3.49 \times 10^{-2}$	$6.94 \times 10^{-3}$		$2.78 \times 10^{-2}$
	85L	$2.74 \times 10^{-2}$		$5.72 \times 10^{-3}$		$2.74 \times 10^{-2}$	$5.72 \times 10^{-3}$		$2.78 \times 10^{-2}$
	100	$2.61 \times 10^{-2}$		$5.16 \times 10^{-3}$		$2.61 \times 10^{-2}$	$5.16 \times 10^{-3}$		$2.24 \times 10^{-2}$
120	$2.37 \times 10^{-2}$		$4.72 \times 10^{-3}$		$2.37 \times 10^{-2}$	$4.72 \times 10^{-3}$		$1.96 \times 10^{-2}$	
150	$2.17 \times 10^{-2}$		$4.35 \times 10^{-3}$		$2.17 \times 10^{-2}$	$4.35 \times 10^{-3}$		$1.61 \times 10^{-2}$	
15M2A	$1.65 \times 10^{-1}$		$2.89 \times 10^{-2}$		$1.65 \times 10^{-1}$	$2.89 \times 10^{-2}$		$1.86 \times 10^{-1}$	
20M2A	$1.23 \times 10^{-1}$		$2.23 \times 10^{-2}$		$1.23 \times 10^{-1}$	$2.23 \times 10^{-2}$		$1.34 \times 10^{-1}$	
25M2A	$1.10 \times 10^{-1}$		$1.98 \times 10^{-2}$		$1.10 \times 10^{-1}$	$1.98 \times 10^{-2}$		$1.14 \times 10^{-1}$	

$K_{AR1}$  : Equivalent factor in the  $M_A$  radial direction when one LM block is used

$K_{AL1}$  : Equivalent factor in the  $M_A$  reverse radial direction when one LM block is used

$K_{AR2}$  : Equivalent factor in the  $M_A$  radial direction when two LM blocks are used in close contact with each other

$K_{AL2}$  : Equivalent factor in the  $M_A$  reverse radial direction when two LM blocks are used in close contact with each other

$K_{B1}$  :  $M_B$  Equivalent factor when one LM block is used

$K_{B2}$  :  $M_B$  Equivalent factor when two LM blocks are used in close contact with each other

$K_{CR}$  : Equivalent factor in the  $M_C$  radial direction

$K_{CL}$  : Equivalent factor in the  $M_C$  reverse radial direction

## Point of Selection

## Calculating the Applied Load

Table3 Equivalent Factors (Models SR, NR-X and NR)

Model No.		Equivalent factor							
		$K_{AR1}$	$K_{AL1}$	$K_{AR2}$	$K_{AL2}$	$K_{B1}$	$K_{B2}$	$K_{CR}$	$K_{CL}$
SR	15W (TB)	$2.08 \times 10^{-1}$	$1.04 \times 10^{-1}$	$3.72 \times 10^{-2}$	$1.86 \times 10^{-2}$	$1.46 \times 10^{-1}$	$2.57 \times 10^{-2}$	$1.69 \times 10^{-1}$	$8.43 \times 10^{-2}$
	15V (SB)	$3.40 \times 10^{-1}$	$1.70 \times 10^{-1}$	$5.00 \times 10^{-2}$	$2.50 \times 10^{-2}$	$2.34 \times 10^{-1}$	$3.37 \times 10^{-2}$	$1.69 \times 10^{-1}$	$8.43 \times 10^{-2}$
	20W (TB)	$1.71 \times 10^{-1}$	$8.56 \times 10^{-2}$	$3.23 \times 10^{-2}$	$1.61 \times 10^{-2}$	$1.20 \times 10^{-1}$	$2.24 \times 10^{-2}$	$1.28 \times 10^{-1}$	$6.40 \times 10^{-2}$
	20V (SB)	$2.69 \times 10^{-1}$	$1.34 \times 10^{-1}$	$4.34 \times 10^{-2}$	$2.17 \times 10^{-2}$	$1.86 \times 10^{-1}$	$2.95 \times 10^{-2}$	$1.28 \times 10^{-1}$	$6.39 \times 10^{-2}$
	25W (TB)	$1.37 \times 10^{-1}$	$6.85 \times 10^{-2}$	$2.57 \times 10^{-2}$	$1.29 \times 10^{-2}$	$9.61 \times 10^{-2}$	$1.78 \times 10^{-2}$	$1.09 \times 10^{-1}$	$5.47 \times 10^{-2}$
	25V (SB)	$2.15 \times 10^{-1}$	$1.08 \times 10^{-1}$	$3.47 \times 10^{-2}$	$1.73 \times 10^{-2}$	$1.49 \times 10^{-1}$	$2.36 \times 10^{-2}$	$1.10 \times 10^{-1}$	$5.48 \times 10^{-2}$
	30W (TB)	$1.14 \times 10^{-1}$	$5.71 \times 10^{-2}$	$2.21 \times 10^{-2}$	$1.10 \times 10^{-2}$	$8.01 \times 10^{-2}$	$1.54 \times 10^{-2}$	$9.16 \times 10^{-2}$	$4.58 \times 10^{-2}$
	30V (SB)	$1.98 \times 10^{-1}$	$9.92 \times 10^{-2}$	$2.98 \times 10^{-2}$	$1.49 \times 10^{-2}$	$1.37 \times 10^{-1}$	$2.01 \times 10^{-2}$	$9.16 \times 10^{-2}$	$4.58 \times 10^{-2}$
	35W (TB)	$1.04 \times 10^{-1}$	$5.21 \times 10^{-2}$	$1.91 \times 10^{-2}$	$9.57 \times 10^{-3}$	$7.30 \times 10^{-2}$	$1.32 \times 10^{-2}$	$7.59 \times 10^{-2}$	$3.80 \times 10^{-2}$
	35V (SB)	$1.70 \times 10^{-1}$	$8.50 \times 10^{-2}$	$2.61 \times 10^{-2}$	$1.31 \times 10^{-2}$	$1.17 \times 10^{-1}$	$1.77 \times 10^{-2}$	$7.59 \times 10^{-2}$	$3.80 \times 10^{-2}$
	45W (TB)	$9.11 \times 10^{-2}$	$4.56 \times 10^{-2}$	$1.69 \times 10^{-2}$	$8.44 \times 10^{-3}$	$6.38 \times 10^{-2}$	$1.17 \times 10^{-2}$	$5.67 \times 10^{-2}$	$2.83 \times 10^{-2}$
	55W (TB)	$6.85 \times 10^{-2}$	$3.42 \times 10^{-2}$	$1.37 \times 10^{-2}$	$6.86 \times 10^{-3}$	$4.80 \times 10^{-2}$	$9.57 \times 10^{-3}$	$5.38 \times 10^{-2}$	$2.69 \times 10^{-2}$
NR-X	25	$1.19 \times 10^{-1}$	$7.64 \times 10^{-2}$	$2.24 \times 10^{-2}$	$1.43 \times 10^{-2}$	$7.47 \times 10^{-2}$	$1.41 \times 10^{-2}$	$9.69 \times 10^{-2}$	$6.20 \times 10^{-2}$
	25L	$9.18 \times 10^{-2}$	$5.87 \times 10^{-2}$	$1.85 \times 10^{-2}$	$1.18 \times 10^{-2}$	$5.78 \times 10^{-2}$	$1.17 \times 10^{-2}$	$9.69 \times 10^{-2}$	$6.21 \times 10^{-2}$
	30	$9.95 \times 10^{-2}$	$6.37 \times 10^{-2}$	$1.90 \times 10^{-2}$	$1.21 \times 10^{-2}$	$6.23 \times 10^{-2}$	$1.19 \times 10^{-2}$	$8.55 \times 10^{-2}$	$5.47 \times 10^{-2}$
	30L	$7.65 \times 10^{-2}$	$4.89 \times 10^{-2}$	$1.57 \times 10^{-2}$	$1.00 \times 10^{-2}$	$4.82 \times 10^{-2}$	$9.91 \times 10^{-3}$	$8.55 \times 10^{-2}$	$5.47 \times 10^{-2}$
	35	$9.08 \times 10^{-2}$	$5.81 \times 10^{-2}$	$1.69 \times 10^{-2}$	$1.08 \times 10^{-2}$	$5.67 \times 10^{-2}$	$1.06 \times 10^{-2}$	$7.17 \times 10^{-2}$	$4.59 \times 10^{-2}$
	35L	$6.88 \times 10^{-2}$	$4.40 \times 10^{-2}$	$1.40 \times 10^{-2}$	$8.96 \times 10^{-3}$	$4.32 \times 10^{-2}$	$8.81 \times 10^{-3}$	$7.17 \times 10^{-2}$	$4.59 \times 10^{-2}$
	45	$7.02 \times 10^{-2}$	$4.50 \times 10^{-2}$	$1.35 \times 10^{-2}$	$8.64 \times 10^{-3}$	$4.37 \times 10^{-2}$	$8.39 \times 10^{-3}$	$5.31 \times 10^{-2}$	$3.40 \times 10^{-2}$
	45L	$5.25 \times 10^{-2}$	$3.36 \times 10^{-2}$	$1.11 \times 10^{-2}$	$7.11 \times 10^{-3}$	$3.31 \times 10^{-2}$	$7.05 \times 10^{-3}$	$5.32 \times 10^{-2}$	$3.41 \times 10^{-2}$
	55	$5.92 \times 10^{-2}$	$3.79 \times 10^{-2}$	$1.15 \times 10^{-2}$	$7.36 \times 10^{-3}$	$3.72 \times 10^{-2}$	$7.21 \times 10^{-3}$	$4.66 \times 10^{-2}$	$2.98 \times 10^{-2}$
	55L	$4.66 \times 10^{-2}$	$2.98 \times 10^{-2}$	$9.43 \times 10^{-3}$	$6.02 \times 10^{-3}$	$2.92 \times 10^{-2}$	$5.93 \times 10^{-3}$	$4.65 \times 10^{-2}$	$2.98 \times 10^{-2}$
	65	$5.12 \times 10^{-2}$	$3.28 \times 10^{-2}$	$1.00 \times 10^{-2}$	$6.40 \times 10^{-3}$	$3.21 \times 10^{-2}$	$6.31 \times 10^{-3}$	$3.93 \times 10^{-2}$	$2.52 \times 10^{-2}$
	65L	$3.66 \times 10^{-2}$	$2.34 \times 10^{-2}$	$7.73 \times 10^{-3}$	$4.93 \times 10^{-3}$	$2.31 \times 10^{-2}$	$4.89 \times 10^{-3}$	$3.93 \times 10^{-2}$	$2.52 \times 10^{-2}$
NR	75	$4.21 \times 10^{-2}$	$2.99 \times 10^{-2}$	$8.31 \times 10^{-3}$	$5.90 \times 10^{-3}$	$3.08 \times 10^{-2}$	$6.13 \times 10^{-3}$	$3.16 \times 10^{-2}$	$2.24 \times 10^{-2}$
	75L	$3.14 \times 10^{-2}$	$2.23 \times 10^{-2}$	$6.74 \times 10^{-3}$	$4.78 \times 10^{-3}$	$2.33 \times 10^{-2}$	$5.04 \times 10^{-3}$	$3.16 \times 10^{-2}$	$2.24 \times 10^{-2}$
	85	$3.70 \times 10^{-2}$	$2.62 \times 10^{-2}$	$7.31 \times 10^{-3}$	$5.19 \times 10^{-3}$	$2.71 \times 10^{-2}$	$5.40 \times 10^{-3}$	$2.80 \times 10^{-2}$	$1.99 \times 10^{-2}$
	85L	$2.80 \times 10^{-2}$	$1.99 \times 10^{-2}$	$6.07 \times 10^{-3}$	$4.31 \times 10^{-3}$	$2.08 \times 10^{-2}$	$4.55 \times 10^{-3}$	$2.80 \times 10^{-2}$	$1.99 \times 10^{-2}$
	100	$3.05 \times 10^{-2}$	$2.17 \times 10^{-2}$	$6.20 \times 10^{-3}$	$4.41 \times 10^{-3}$	$2.26 \times 10^{-2}$	$4.63 \times 10^{-3}$	$2.38 \times 10^{-2}$	$1.69 \times 10^{-2}$
	100L	$2.74 \times 10^{-2}$	$1.95 \times 10^{-2}$	$5.46 \times 10^{-3}$	$3.87 \times 10^{-3}$	$2.00 \times 10^{-2}$	$4.00 \times 10^{-3}$	$2.38 \times 10^{-2}$	$1.69 \times 10^{-2}$

$K_{AR1}$  : Equivalent factor in the  $M_A$  radial direction when one LM block is used  
 $K_{AL1}$  : Equivalent factor in the  $M_A$  reverse radial direction when one LM block is used  
 $K_{AR2}$  : Equivalent factor in the  $M_A$  radial direction when two LM blocks are used in close contact with each other  
 $K_{AL2}$  : Equivalent factor in the  $M_A$  reverse radial direction when two LM blocks are used in close contact with each other

$K_{B1}$  :  $M_B$  Equivalent factor when one LM block is used  
 $K_{B2}$  :  $M_B$  Equivalent factor when two LM blocks are used in close contact with each other  
 $K_{CR}$  : Equivalent factor in the  $M_C$  radial direction  
 $K_{CL}$  : Equivalent factor in the  $M_C$  reverse radial direction

Table4 Equivalent Factors (Models NRS-X, NRS, HRW, and RSX)

Model No.		Equivalent factor									
		$K_{AR1}$	$K_{AL1}$	$K_{AR2}$	$K_{AL2}$	$K_{B1}$	$K_{B2}$	$K_{CR}$	$K_{CL}$		
NRS-X	25	$1.15 \times 10^{-3}$	$9.66 \times 10^{-2}$	$2.16 \times 10^{-2}$	$1.81 \times 10^{-2}$	$1.06 \times 10^{-1}$	$1.98 \times 10^{-2}$	$9.51 \times 10^{-2}$	$7.99 \times 10^{-2}$		
	25L	$8.85 \times 10^{-2}$	$7.44 \times 10^{-2}$	$1.79 \times 10^{-2}$	$1.50 \times 10^{-2}$	$8.14 \times 10^{-2}$	$1.64 \times 10^{-2}$	$9.51 \times 10^{-2}$	$7.99 \times 10^{-2}$		
	30	$9.58 \times 10^{-2}$	$8.05 \times 10^{-2}$	$1.83 \times 10^{-2}$	$1.53 \times 10^{-2}$	$8.81 \times 10^{-2}$	$1.68 \times 10^{-2}$	$8.40 \times 10^{-2}$	$7.05 \times 10^{-2}$		
	30L	$7.38 \times 10^{-2}$	$6.20 \times 10^{-2}$	$1.51 \times 10^{-2}$	$1.27 \times 10^{-2}$	$6.79 \times 10^{-2}$	$1.39 \times 10^{-2}$	$8.40 \times 10^{-2}$	$7.05 \times 10^{-2}$		
	35	$8.73 \times 10^{-2}$	$7.33 \times 10^{-2}$	$1.62 \times 10^{-2}$	$1.36 \times 10^{-2}$	$8.03 \times 10^{-2}$	$1.49 \times 10^{-2}$	$7.04 \times 10^{-2}$	$5.91 \times 10^{-2}$		
	35L	$6.63 \times 10^{-2}$	$5.57 \times 10^{-2}$	$1.35 \times 10^{-2}$	$1.13 \times 10^{-2}$	$6.10 \times 10^{-2}$	$1.24 \times 10^{-2}$	$7.04 \times 10^{-2}$	$5.91 \times 10^{-2}$		
	45	$6.78 \times 10^{-2}$	$5.69 \times 10^{-2}$	$1.30 \times 10^{-2}$	$1.09 \times 10^{-2}$	$6.23 \times 10^{-2}$	$1.19 \times 10^{-2}$	$5.22 \times 10^{-2}$	$4.39 \times 10^{-2}$		
	45L	$5.07 \times 10^{-2}$	$4.26 \times 10^{-2}$	$1.07 \times 10^{-2}$	$8.99 \times 10^{-3}$	$4.66 \times 10^{-2}$	$9.86 \times 10^{-3}$	$5.22 \times 10^{-2}$	$4.39 \times 10^{-2}$		
	55	$5.71 \times 10^{-2}$	$4.79 \times 10^{-2}$	$1.10 \times 10^{-2}$	$9.24 \times 10^{-3}$	$5.25 \times 10^{-2}$	$1.01 \times 10^{-2}$	$4.58 \times 10^{-2}$	$3.84 \times 10^{-2}$		
	55L	$4.50 \times 10^{-2}$	$3.78 \times 10^{-2}$	$9.14 \times 10^{-3}$	$7.65 \times 10^{-3}$	$4.14 \times 10^{-2}$	$8.39 \times 10^{-3}$	$4.57 \times 10^{-2}$	$3.84 \times 10^{-2}$		
	65	$4.93 \times 10^{-2}$	$4.14 \times 10^{-2}$	$9.70 \times 10^{-3}$	$8.15 \times 10^{-3}$	$4.53 \times 10^{-2}$	$8.88 \times 10^{-3}$	$3.86 \times 10^{-2}$	$3.25 \times 10^{-2}$		
	65L	$3.54 \times 10^{-2}$	$2.97 \times 10^{-2}$	$7.47 \times 10^{-3}$	$6.30 \times 10^{-3}$	$3.25 \times 10^{-2}$	$6.86 \times 10^{-3}$	$3.86 \times 10^{-2}$	$3.25 \times 10^{-2}$		
NRS	75	$4.05 \times 10^{-2}$		$8.01 \times 10^{-3}$		$4.05 \times 10^{-2}$		$8.01 \times 10^{-3}$		$3.20 \times 10^{-2}$	
	75L	$3.03 \times 10^{-2}$		$6.50 \times 10^{-3}$		$3.03 \times 10^{-2}$		$6.50 \times 10^{-3}$		$3.20 \times 10^{-2}$	
	85	$3.56 \times 10^{-2}$		$7.05 \times 10^{-3}$		$3.56 \times 10^{-2}$		$7.05 \times 10^{-3}$		$2.83 \times 10^{-2}$	
	85L	$2.70 \times 10^{-2}$		$5.87 \times 10^{-3}$		$2.70 \times 10^{-2}$		$5.87 \times 10^{-3}$		$2.83 \times 10^{-2}$	
	100	$2.93 \times 10^{-2}$		$5.97 \times 10^{-3}$		$2.93 \times 10^{-2}$		$5.97 \times 10^{-3}$		$2.41 \times 10^{-2}$	
	100L	$2.65 \times 10^{-2}$		$5.27 \times 10^{-3}$		$2.65 \times 10^{-2}$		$5.27 \times 10^{-3}$		$2.41 \times 10^{-2}$	
HRW	12	$2.72 \times 10^{-1}$	$1.93 \times 10^{-1}$	$5.16 \times 10^{-2}$	$3.65 \times 10^{-2}$	$5.47 \times 10^{-1}$	$1.04 \times 10^{-1}$	$1.40 \times 10^{-1}$	$9.92 \times 10^{-2}$		
	14	$2.28 \times 10^{-1}$	$1.61 \times 10^{-1}$	$4.16 \times 10^{-2}$	$2.94 \times 10^{-2}$	$4.54 \times 10^{-1}$	$8.28 \times 10^{-2}$	$1.01 \times 10^{-1}$	$7.18 \times 10^{-2}$		
	17	$1.96 \times 10^{-1}$		$3.34 \times 10^{-2}$		$1.96 \times 10^{-1}$		$3.34 \times 10^{-2}$		$6.30 \times 10^{-2}$	
	21	$1.65 \times 10^{-1}$		$2.90 \times 10^{-2}$		$1.65 \times 10^{-1}$		$2.90 \times 10^{-2}$		$5.89 \times 10^{-2}$	
	27	$1.30 \times 10^{-1}$		$2.34 \times 10^{-2}$		$1.30 \times 10^{-1}$		$2.34 \times 10^{-2}$		$5.11 \times 10^{-2}$	
	35	$8.69 \times 10^{-2}$		$1.60 \times 10^{-2}$		$8.69 \times 10^{-2}$		$1.60 \times 10^{-2}$		$3.06 \times 10^{-2}$	
	50	$6.52 \times 10^{-2}$		$1.22 \times 10^{-2}$		$6.52 \times 10^{-2}$		$1.22 \times 10^{-2}$		$2.35 \times 10^{-2}$	
	60	$5.80 \times 10^{-2}$		$1.08 \times 10^{-2}$		$5.80 \times 10^{-2}$		$1.08 \times 10^{-2}$		$1.77 \times 10^{-2}$	

## Point of Selection

## Calculating the Applied Load

Model No.		Equivalent factor							
		$K_{AR1}$	$K_{AL1}$	$K_{AR2}$	$K_{AL2}$	$K_{B1}$	$K_{B2}$	$K_{CR}$	$K_{CL}$
RSX	5M	$6.68 \times 10^{-1}$		$9.11 \times 10^{-2}$		$6.80 \times 10^{-1}$	$9.24 \times 10^{-2}$		$3.86 \times 10^{-1}$
	5NM	$5.25 \times 10^{-1}$		$8.01 \times 10^{-2}$		$5.36 \times 10^{-1}$	$8.12 \times 10^{-2}$		$3.86 \times 10^{-1}$
	5WM	$4.58 \times 10^{-1}$		$7.39 \times 10^{-2}$		$4.65 \times 10^{-1}$	$7.51 \times 10^{-2}$		$1.96 \times 10^{-1}$
	5WNM	$3.31 \times 10^{-1}$		$5.98 \times 10^{-2}$		$3.36 \times 10^{-1}$	$6.06 \times 10^{-2}$		$1.96 \times 10^{-1}$
	7SM	$5.90 \times 10^{-1}$		$7.87 \times 10^{-2}$		$6.12 \times 10^{-1}$	$8.15 \times 10^{-2}$		$2.59 \times 10^{-1}$
	7M	$4.72 \times 10^{-1}$		$6.68 \times 10^{-2}$		$4.87 \times 10^{-1}$	$6.88 \times 10^{-2}$		$2.59 \times 10^{-1}$
	7NM	$3.10 \times 10^{-1}$		$5.18 \times 10^{-2}$		$3.20 \times 10^{-1}$	$5.33 \times 10^{-2}$		$2.59 \times 10^{-1}$
	7WSM	$5.23 \times 10^{-1}$		$6.75 \times 10^{-2}$		$5.43 \times 10^{-1}$	$6.95 \times 10^{-2}$		$1.36 \times 10^{-1}$
	7WM	$3.10 \times 10^{-1}$		$5.34 \times 10^{-2}$		$3.20 \times 10^{-1}$	$5.50 \times 10^{-2}$		$1.36 \times 10^{-1}$
	7WNM	$2.21 \times 10^{-1}$		$4.18 \times 10^{-2}$		$2.27 \times 10^{-1}$	$4.32 \times 10^{-2}$		$1.36 \times 10^{-1}$
	9SM	$5.37 \times 10^{-1}$		$6.77 \times 10^{-2}$		$5.57 \times 10^{-1}$	$7.00 \times 10^{-2}$		$2.17 \times 10^{-1}$
	9M	$3.10 \times 10^{-1}$		$5.28 \times 10^{-2}$		$3.19 \times 10^{-1}$	$5.44 \times 10^{-2}$		$2.17 \times 10^{-1}$
	9NM	$2.17 \times 10^{-1}$		$4.13 \times 10^{-2}$		$2.24 \times 10^{-1}$	$4.27 \times 10^{-2}$		$2.17 \times 10^{-1}$
	9WSM	$4.16 \times 10^{-1}$		$5.80 \times 10^{-2}$		$4.30 \times 10^{-1}$	$5.98 \times 10^{-2}$		$1.06 \times 10^{-1}$
	9WM	$2.31 \times 10^{-1}$		$4.31 \times 10^{-2}$		$2.38 \times 10^{-1}$	$4.43 \times 10^{-2}$		$1.06 \times 10^{-1}$
	9WNM	$1.75 \times 10^{-1}$		$3.38 \times 10^{-2}$		$1.81 \times 10^{-1}$	$3.48 \times 10^{-2}$		$1.06 \times 10^{-1}$
	12SM	$5.04 \times 10^{-1}$		$5.52 \times 10^{-2}$		$5.04 \times 10^{-1}$	$5.52 \times 10^{-2}$		$1.52 \times 10^{-1}$
	12M	$2.96 \times 10^{-1}$		$4.55 \times 10^{-2}$		$2.96 \times 10^{-1}$	$4.55 \times 10^{-2}$		$1.52 \times 10^{-1}$
	12NM	$1.96 \times 10^{-1}$		$3.50 \times 10^{-2}$		$1.96 \times 10^{-1}$	$3.50 \times 10^{-2}$		$1.52 \times 10^{-1}$
	12WSM	$3.32 \times 10^{-1}$		$5.07 \times 10^{-2}$		$3.32 \times 10^{-1}$	$5.07 \times 10^{-2}$		$7.95 \times 10^{-2}$
	12WM	$2.10 \times 10^{-1}$		$3.69 \times 10^{-2}$		$2.10 \times 10^{-1}$	$3.69 \times 10^{-2}$		$7.95 \times 10^{-2}$
	12WNM	$1.46 \times 10^{-1}$		$2.85 \times 10^{-2}$		$1.46 \times 10^{-1}$	$2.85 \times 10^{-2}$		$7.95 \times 10^{-2}$
	15SM	$3.36 \times 10^{-1}$		$4.58 \times 10^{-2}$		$3.36 \times 10^{-1}$	$4.58 \times 10^{-2}$		$1.41 \times 10^{-1}$
	15M	$2.34 \times 10^{-1}$		$3.65 \times 10^{-2}$		$2.34 \times 10^{-1}$	$3.65 \times 10^{-2}$		$1.41 \times 10^{-1}$
	15NM	$1.45 \times 10^{-1}$		$2.75 \times 10^{-2}$		$1.45 \times 10^{-1}$	$2.75 \times 10^{-2}$		$1.41 \times 10^{-1}$
	15WSM	$2.34 \times 10^{-1}$		$3.81 \times 10^{-2}$		$2.34 \times 10^{-1}$	$3.81 \times 10^{-2}$		$4.82 \times 10^{-2}$
	15WM	$1.66 \times 10^{-1}$		$2.97 \times 10^{-2}$		$1.66 \times 10^{-1}$	$2.97 \times 10^{-2}$		$4.82 \times 10^{-2}$
	15WNM	$1.15 \times 10^{-1}$		$2.28 \times 10^{-2}$		$1.15 \times 10^{-1}$	$2.28 \times 10^{-2}$		$4.82 \times 10^{-2}$
	9M1	$3.10 \times 10^{-1}$		$5.28 \times 10^{-2}$		$3.19 \times 10^{-1}$	$5.44 \times 10^{-2}$		$2.17 \times 10^{-1}$
	9M1N	$2.17 \times 10^{-1}$		$4.13 \times 10^{-2}$		$2.24 \times 10^{-1}$	$4.27 \times 10^{-2}$		$2.17 \times 10^{-1}$
	9M1W	$2.31 \times 10^{-1}$		$4.31 \times 10^{-2}$		$2.38 \times 10^{-1}$	$4.43 \times 10^{-2}$		$1.06 \times 10^{-1}$
	9M1WN	$1.75 \times 10^{-1}$		$3.38 \times 10^{-2}$		$1.81 \times 10^{-1}$	$3.48 \times 10^{-2}$		$1.06 \times 10^{-1}$
	12M1	$2.96 \times 10^{-1}$		$4.55 \times 10^{-2}$		$2.96 \times 10^{-1}$	$4.55 \times 10^{-2}$		$1.52 \times 10^{-1}$
	12M1N	$1.96 \times 10^{-1}$		$3.50 \times 10^{-2}$		$1.96 \times 10^{-1}$	$3.50 \times 10^{-2}$		$1.52 \times 10^{-1}$
12M1W	$2.10 \times 10^{-1}$		$3.69 \times 10^{-2}$		$2.10 \times 10^{-1}$	$3.69 \times 10^{-2}$		$7.95 \times 10^{-2}$	
12M1WN	$1.46 \times 10^{-1}$		$2.85 \times 10^{-2}$		$1.46 \times 10^{-1}$	$2.85 \times 10^{-2}$		$7.95 \times 10^{-2}$	
15M1	$2.34 \times 10^{-1}$		$3.65 \times 10^{-2}$		$2.34 \times 10^{-1}$	$3.65 \times 10^{-2}$		$1.41 \times 10^{-1}$	
15M1N	$1.45 \times 10^{-1}$		$2.75 \times 10^{-2}$		$1.45 \times 10^{-1}$	$2.75 \times 10^{-2}$		$1.41 \times 10^{-1}$	
15M1W	$1.66 \times 10^{-1}$		$2.97 \times 10^{-2}$		$1.66 \times 10^{-1}$	$2.97 \times 10^{-2}$		$4.82 \times 10^{-2}$	
15M1WN	$1.15 \times 10^{-1}$		$2.28 \times 10^{-2}$		$1.15 \times 10^{-1}$	$2.28 \times 10^{-2}$		$4.82 \times 10^{-2}$	

$K_{AR1}$  : Equivalent factor in the  $M_A$  radial direction when one LM block is used

$K_{AL1}$  : Equivalent factor in the  $M_A$  reverse radial direction when one LM block is used

$K_{AR2}$  : Equivalent factor in the  $M_A$  radial direction when two LM blocks are used in close contact with each other

$K_{AL2}$  : Equivalent factor in the  $M_A$  reverse radial direction when two LM blocks are used in close contact with each other

$K_{B1}$  :  $M_B$  Equivalent factor when one LM block is used

$K_{B2}$  :  $M_B$  Equivalent factor when two LM blocks are used in close contact with each other

$K_{CR}$  : Equivalent factor in the  $M_C$  radial direction

$K_{CL}$  : Equivalent factor in the  $M_C$  reverse radial direction

Table5 Equivalent Factors (Models RSR and HR)

Model No.		Equivalent factor							
		$K_{AR1}$	$K_{AL1}$	$K_{AR2}$	$K_{AL2}$	$K_{B1}$	$K_{B2}$	$K_{CR}$	$K_{CL}$
RSR	2N	$6.81 \times 10^{-1}$		$1.28 \times 10^{-1}$		$6.81 \times 10^{-1}$	$1.28 \times 10^{-1}$	$8.69 \times 10^{-1}$	
	2WN	$5.10 \times 10^{-1}$		$9.32 \times 10^{-2}$		$5.10 \times 10^{-1}$	$9.32 \times 10^{-2}$	$4.54 \times 10^{-1}$	
	3M	$9.20 \times 10^{-1}$		$1.27 \times 10^{-1}$		$9.20 \times 10^{-1}$	$1.27 \times 10^{-1}$	$6.06 \times 10^{-1}$	
	3N	$6.06 \times 10^{-1}$		$1.01 \times 10^{-1}$		$6.06 \times 10^{-1}$	$1.01 \times 10^{-1}$	$6.06 \times 10^{-1}$	
	3W	$7.03 \times 10^{-1}$		$1.06 \times 10^{-1}$		$7.03 \times 10^{-1}$	$1.06 \times 10^{-1}$	$3.17 \times 10^{-1}$	
	3WN	$4.76 \times 10^{-1}$		$8.27 \times 10^{-2}$		$4.76 \times 10^{-1}$	$8.27 \times 10^{-2}$	$3.17 \times 10^{-1}$	
	9M1K	$3.06 \times 10^{-1}$		$5.19 \times 10^{-2}$		$3.06 \times 10^{-1}$	$5.19 \times 10^{-2}$	$2.15 \times 10^{-1}$	
	9M1N	$2.15 \times 10^{-1}$		$4.08 \times 10^{-2}$		$2.15 \times 10^{-1}$	$4.08 \times 10^{-2}$	$2.15 \times 10^{-1}$	
	9M1WV	$2.44 \times 10^{-1}$		$4.22 \times 10^{-2}$		$2.44 \times 10^{-1}$	$4.22 \times 10^{-2}$	$1.09 \times 10^{-1}$	
	9M1WN	$1.73 \times 10^{-1}$		$3.33 \times 10^{-2}$		$1.73 \times 10^{-1}$	$3.33 \times 10^{-2}$	$1.09 \times 10^{-1}$	
	12M1V	$3.52 \times 10^{-1}$	$2.46 \times 10^{-1}$	$5.37 \times 10^{-2}$	$3.76 \times 10^{-2}$	$2.81 \times 10^{-1}$	$4.21 \times 10^{-2}$	$2.09 \times 10^{-1}$	$1.46 \times 10^{-1}$
	12M1N	$2.30 \times 10^{-1}$	$1.61 \times 10^{-1}$	$4.08 \times 10^{-2}$	$2.85 \times 10^{-2}$	$1.85 \times 10^{-1}$	$3.25 \times 10^{-2}$	$2.09 \times 10^{-1}$	$1.46 \times 10^{-1}$
	12M1WV	$2.47 \times 10^{-1}$	$1.73 \times 10^{-1}$	$4.38 \times 10^{-2}$	$3.07 \times 10^{-2}$	$1.99 \times 10^{-1}$	$3.49 \times 10^{-2}$	$1.02 \times 10^{-1}$	$7.15 \times 10^{-2}$
	12M1WN	$1.71 \times 10^{-1}$	$1.20 \times 10^{-1}$	$3.36 \times 10^{-2}$	$2.35 \times 10^{-2}$	$1.38 \times 10^{-1}$	$2.70 \times 10^{-2}$	$1.02 \times 10^{-1}$	$7.15 \times 10^{-2}$
	14WV	$2.10 \times 10^{-1}$	$1.47 \times 10^{-1}$	$3.89 \times 10^{-2}$	$2.73 \times 10^{-2}$	$1.69 \times 10^{-1}$	$3.10 \times 10^{-2}$	$8.22 \times 10^{-2}$	$5.75 \times 10^{-2}$
	15M1V	$2.77 \times 10^{-1}$	$1.94 \times 10^{-1}$	$4.38 \times 10^{-2}$	$3.07 \times 10^{-2}$	$2.21 \times 10^{-1}$	$3.45 \times 10^{-2}$	$1.69 \times 10^{-1}$	$1.18 \times 10^{-1}$
	15M1N	$1.70 \times 10^{-1}$	$1.19 \times 10^{-1}$	$3.24 \times 10^{-2}$	$2.27 \times 10^{-2}$	$1.37 \times 10^{-1}$	$2.59 \times 10^{-2}$	$1.69 \times 10^{-1}$	$1.18 \times 10^{-1}$
	15M1WV	$1.95 \times 10^{-1}$	$1.36 \times 10^{-1}$	$3.52 \times 10^{-2}$	$2.46 \times 10^{-2}$	$1.56 \times 10^{-1}$	$2.80 \times 10^{-2}$	$5.83 \times 10^{-2}$	$4.08 \times 10^{-2}$
	15M1WN	$1.34 \times 10^{-1}$	$9.41 \times 10^{-2}$	$2.68 \times 10^{-2}$	$1.88 \times 10^{-2}$	$1.09 \times 10^{-1}$	$2.16 \times 10^{-2}$	$5.82 \times 10^{-2}$	$4.08 \times 10^{-2}$
	20M1V	$1.68 \times 10^{-1}$	$1.18 \times 10^{-1}$	$2.92 \times 10^{-2}$	$2.04 \times 10^{-2}$	$1.35 \times 10^{-1}$	$2.32 \times 10^{-2}$	$1.30 \times 10^{-1}$	$9.13 \times 10^{-2}$
20M1N	$1.20 \times 10^{-1}$	$8.39 \times 10^{-2}$	$2.30 \times 10^{-2}$	$1.61 \times 10^{-2}$	$9.68 \times 10^{-2}$	$1.84 \times 10^{-2}$	$1.30 \times 10^{-1}$	$9.13 \times 10^{-2}$	
HR	918	$2.65 \times 10^{-1}$		$3.58 \times 10^{-2}$		$2.65 \times 10^{-1}$	$3.58 \times 10^{-2}$	—	—
	1123	$2.08 \times 10^{-1}$		$3.17 \times 10^{-2}$		$2.08 \times 10^{-1}$	$3.17 \times 10^{-2}$	—	—
	1530	$1.56 \times 10^{-1}$		$2.39 \times 10^{-2}$		$1.56 \times 10^{-1}$	$2.39 \times 10^{-2}$	—	—
	2042	$1.11 \times 10^{-1}$		$1.80 \times 10^{-2}$		$1.11 \times 10^{-1}$	$1.80 \times 10^{-2}$	—	—
	2042T	$8.64 \times 10^{-2}$		$1.53 \times 10^{-2}$		$8.64 \times 10^{-2}$	$1.53 \times 10^{-2}$	—	—
	2555	$7.79 \times 10^{-2}$		$1.38 \times 10^{-2}$		$7.79 \times 10^{-2}$	$1.38 \times 10^{-2}$	—	—
	2555T	$6.13 \times 10^{-2}$		$1.17 \times 10^{-2}$		$6.13 \times 10^{-2}$	$1.17 \times 10^{-2}$	—	—
	3065	$6.92 \times 10^{-2}$		$1.15 \times 10^{-2}$		$6.92 \times 10^{-2}$	$1.15 \times 10^{-2}$	—	—
	3065T	$5.45 \times 10^{-2}$		$9.92 \times 10^{-3}$		$5.45 \times 10^{-2}$	$9.92 \times 10^{-3}$	—	—
	3575	$6.23 \times 10^{-2}$		$1.08 \times 10^{-2}$		$6.23 \times 10^{-2}$	$1.08 \times 10^{-2}$	—	—
	3575T	$4.90 \times 10^{-2}$		$9.42 \times 10^{-3}$		$4.90 \times 10^{-2}$	$9.42 \times 10^{-3}$	—	—
	4085	$5.19 \times 10^{-2}$		$9.53 \times 10^{-3}$		$5.19 \times 10^{-2}$	$9.53 \times 10^{-3}$	—	—
	4085T	$4.09 \times 10^{-2}$		$7.97 \times 10^{-3}$		$4.09 \times 10^{-2}$	$7.97 \times 10^{-3}$	—	—
	50105	$4.15 \times 10^{-2}$		$7.40 \times 10^{-3}$		$4.15 \times 10^{-2}$	$7.40 \times 10^{-3}$	—	—
	50105T	$3.27 \times 10^{-2}$		$6.26 \times 10^{-3}$		$3.27 \times 10^{-2}$	$6.26 \times 10^{-3}$	—	—
60125	$2.88 \times 10^{-2}$		$5.18 \times 10^{-3}$		$2.88 \times 10^{-2}$	$5.18 \times 10^{-3}$	—	—	

$K_{AR1}$  : Equivalent factor in the  $M_A$  radial direction when one LM block is used

$K_{AL1}$  : Equivalent factor in the  $M_A$  reverse radial direction when one LM block is used

$K_{AR2}$  : Equivalent factor in the  $M_A$  radial direction when two LM blocks are used in close contact with each other

$K_{AL2}$  : Equivalent factor in the  $M_A$  reverse radial direction when two LM blocks are used in close contact with each other

$K_{B1}$  :  $M_B$  Equivalent factor when one LM block is used

$K_{B2}$  :  $M_B$  Equivalent factor when two LM blocks are used in close contact with each other

$K_{CR}$  : Equivalent factor in the  $M_C$  radial direction

$K_{CL}$  : Equivalent factor in the  $M_C$  reverse radial direction

## Point of Selection

## Calculating the Applied Load

Table6 Equivalent Factors (Models GSR, CSR, MX, JR, NSR, SRG, SRN, and SRW)

Model No.		Equivalent factor							
		$K_{AR1}$	$K_{AL1}$	$K_{AR2}$	$K_{AL2}$	$K_{B1}$	$K_{B2}$	$K_{CR}$	$K_{CL}$
GSR	15T	$1.61 \times 10^{-1}$	$1.44 \times 10^{-1}$	$2.88 \times 10^{-2}$	$2.59 \times 10^{-2}$	$1.68 \times 10^{-1}$	$3.01 \times 10^{-2}$	—	—
	15V	$2.21 \times 10^{-1}$	$1.99 \times 10^{-1}$	$3.54 \times 10^{-2}$	$3.18 \times 10^{-2}$	$2.30 \times 10^{-1}$	$3.68 \times 10^{-2}$	—	—
	20T	$1.28 \times 10^{-1}$	$1.16 \times 10^{-1}$	$2.34 \times 10^{-2}$	$2.10 \times 10^{-2}$	$1.34 \times 10^{-1}$	$2.44 \times 10^{-2}$	—	—
	20V	$1.77 \times 10^{-1}$	$1.59 \times 10^{-1}$	$2.87 \times 10^{-2}$	$2.58 \times 10^{-2}$	$1.84 \times 10^{-1}$	$2.99 \times 10^{-2}$	—	—
	25T	$1.07 \times 10^{-1}$	$9.63 \times 10^{-2}$	$1.97 \times 10^{-2}$	$1.77 \times 10^{-2}$	$1.12 \times 10^{-1}$	$2.06 \times 10^{-2}$	—	—
	25V	$1.47 \times 10^{-1}$	$1.33 \times 10^{-1}$	$2.42 \times 10^{-2}$	$2.18 \times 10^{-2}$	$1.53 \times 10^{-1}$	$2.52 \times 10^{-2}$	—	—
	30T	$9.17 \times 10^{-2}$	$8.26 \times 10^{-2}$	$1.68 \times 10^{-2}$	$1.51 \times 10^{-2}$	$9.59 \times 10^{-2}$	$1.76 \times 10^{-2}$	—	—
	35T	$8.03 \times 10^{-2}$	$7.22 \times 10^{-2}$	$1.48 \times 10^{-2}$	$1.33 \times 10^{-2}$	$8.39 \times 10^{-2}$	$1.55 \times 10^{-2}$	—	—
CSR	15	$1.66 \times 10^{-1}$	—	—	—	$1.66 \times 10^{-1}$	—	—	—
	20S	$1.26 \times 10^{-1}$	—	—	—	$1.26 \times 10^{-1}$	—	—	—
	20	$9.88 \times 10^{-2}$	—	—	—	$9.88 \times 10^{-2}$	—	—	—
	25S	$1.12 \times 10^{-1}$	—	—	—	$1.12 \times 10^{-1}$	—	—	—
	25	$8.23 \times 10^{-2}$	—	—	—	$8.23 \times 10^{-2}$	—	—	—
	30S	$8.97 \times 10^{-2}$	—	—	—	$8.97 \times 10^{-2}$	—	—	—
	30	$7.05 \times 10^{-2}$	—	—	—	$7.05 \times 10^{-2}$	—	—	—
	35	$6.17 \times 10^{-2}$	—	—	—	$6.17 \times 10^{-2}$	—	—	—
MX	5	$4.27 \times 10^{-1}$	—	$7.01 \times 10^{-2}$	—	$4.27 \times 10^{-1}$	$7.01 \times 10^{-2}$	—	—
	7W	$2.18 \times 10^{-1}$	—	$4.13 \times 10^{-2}$	—	$2.18 \times 10^{-1}$	$4.13 \times 10^{-2}$	—	—
JR	25	$1.12 \times 10^{-1}$	—	$2.02 \times 10^{-2}$	—	$1.12 \times 10^{-1}$	$2.02 \times 10^{-2}$	$9.96 \times 10^{-2}$	—
	35	$7.85 \times 10^{-2}$	—	$1.56 \times 10^{-2}$	—	$7.85 \times 10^{-2}$	$1.56 \times 10^{-2}$	$6.69 \times 10^{-2}$	—
	45	$6.73 \times 10^{-2}$	—	$1.21 \times 10^{-2}$	—	$6.73 \times 10^{-2}$	$1.21 \times 10^{-2}$	$5.20 \times 10^{-2}$	—
	55	$5.61 \times 10^{-2}$	—	$1.03 \times 10^{-2}$	—	$5.61 \times 10^{-2}$	$1.03 \times 10^{-2}$	$4.26 \times 10^{-2}$	—
NSR	20TBC	$2.29 \times 10^{-1}$	—	$2.68 \times 10^{-2}$	—	$2.29 \times 10^{-1}$	$2.68 \times 10^{-2}$	—	—
	25TBC	$2.01 \times 10^{-1}$	—	$2.27 \times 10^{-2}$	—	$2.01 \times 10^{-1}$	$2.27 \times 10^{-2}$	—	—
	30TBC	$1.85 \times 10^{-1}$	—	$1.93 \times 10^{-2}$	—	$1.85 \times 10^{-1}$	$1.93 \times 10^{-2}$	—	—
	40TBC	$1.39 \times 10^{-1}$	—	$1.60 \times 10^{-2}$	—	$1.39 \times 10^{-1}$	$1.60 \times 10^{-2}$	—	—
	50TBC	$1.24 \times 10^{-1}$	—	$1.42 \times 10^{-2}$	—	$1.24 \times 10^{-1}$	$1.42 \times 10^{-2}$	—	—
	70TBC	$9.99 \times 10^{-2}$	—	$1.15 \times 10^{-2}$	—	$9.99 \times 10^{-2}$	$1.15 \times 10^{-2}$	—	—

Model No.		Equivalent factor							
		$K_{AR1}$	$K_{AL1}$	$K_{AR2}$	$K_{AL2}$	$K_{B1}$	$K_{B2}$	$K_{CR}$	$K_{CL}$
SRG	15X	$1.23 \times 10^{-1}$		$2.07 \times 10^{-2}$		$1.23 \times 10^{-1}$	$2.07 \times 10^{-2}$	$1.04 \times 10^{-1}$	
	20X	$9.60 \times 10^{-2}$		$1.71 \times 10^{-2}$		$9.60 \times 10^{-2}$	$1.71 \times 10^{-2}$	$8.00 \times 10^{-2}$	
	20XL	$7.21 \times 10^{-2}$		$1.42 \times 10^{-2}$		$7.21 \times 10^{-2}$	$1.42 \times 10^{-2}$	$8.00 \times 10^{-2}$	
	25X	$8.96 \times 10^{-2}$		$1.55 \times 10^{-2}$		$8.96 \times 10^{-2}$	$1.55 \times 10^{-2}$	$7.23 \times 10^{-2}$	
	25XL	$6.99 \times 10^{-2}$		$1.31 \times 10^{-2}$		$6.99 \times 10^{-2}$	$1.31 \times 10^{-2}$	$7.23 \times 10^{-2}$	
	30X	$8.06 \times 10^{-2}$		$1.33 \times 10^{-2}$		$8.06 \times 10^{-2}$	$1.33 \times 10^{-2}$	$5.61 \times 10^{-2}$	
	30XL	$6.12 \times 10^{-2}$		$1.11 \times 10^{-2}$		$6.12 \times 10^{-2}$	$1.11 \times 10^{-2}$	$5.61 \times 10^{-2}$	
	35	$7.14 \times 10^{-2}$		$1.18 \times 10^{-2}$		$7.14 \times 10^{-2}$	$1.18 \times 10^{-2}$	$4.98 \times 10^{-2}$	
	35L	$5.26 \times 10^{-2}$		$9.67 \times 10^{-3}$		$5.26 \times 10^{-2}$	$9.67 \times 10^{-3}$	$4.98 \times 10^{-2}$	
	35SL	$4.40 \times 10^{-2}$		$8.34 \times 10^{-3}$		$4.40 \times 10^{-2}$	$8.34 \times 10^{-3}$	$4.98 \times 10^{-2}$	
	45	$5.49 \times 10^{-2}$		$9.58 \times 10^{-3}$		$5.49 \times 10^{-2}$	$9.58 \times 10^{-3}$	$3.85 \times 10^{-2}$	
	45L	$4.18 \times 10^{-2}$		$7.93 \times 10^{-3}$		$4.18 \times 10^{-2}$	$7.93 \times 10^{-3}$	$3.85 \times 10^{-2}$	
	45SL	$3.28 \times 10^{-2}$		$6.56 \times 10^{-3}$		$3.28 \times 10^{-2}$	$6.56 \times 10^{-3}$	$3.85 \times 10^{-2}$	
	55	$4.56 \times 10^{-2}$		$8.04 \times 10^{-3}$		$4.56 \times 10^{-2}$	$8.04 \times 10^{-3}$	$3.25 \times 10^{-2}$	
	55L	$3.37 \times 10^{-2}$		$6.42 \times 10^{-3}$		$3.37 \times 10^{-2}$	$6.42 \times 10^{-3}$	$3.25 \times 10^{-2}$	
	55SL	$2.56 \times 10^{-2}$		$5.22 \times 10^{-3}$		$2.56 \times 10^{-2}$	$5.22 \times 10^{-3}$	$3.25 \times 10^{-2}$	
	65	$3.54 \times 10^{-2}$		$6.06 \times 10^{-3}$		$3.54 \times 10^{-2}$	$6.06 \times 10^{-3}$	$2.70 \times 10^{-2}$	
	65L	$2.63 \times 10^{-2}$		$4.97 \times 10^{-3}$		$2.63 \times 10^{-2}$	$4.97 \times 10^{-3}$	$2.70 \times 10^{-2}$	
	65SL	$1.97 \times 10^{-2}$		$4.01 \times 10^{-3}$		$1.97 \times 10^{-2}$	$4.01 \times 10^{-3}$	$2.70 \times 10^{-2}$	
	85LC	$2.19 \times 10^{-2}$		$4.15 \times 10^{-3}$		$2.19 \times 10^{-2}$	$4.15 \times 10^{-3}$	$1.91 \times 10^{-2}$	
100LC	$1.95 \times 10^{-2}$		$3.67 \times 10^{-3}$		$1.95 \times 10^{-2}$	$3.67 \times 10^{-3}$	$1.62 \times 10^{-2}$		
SRN	35	$7.14 \times 10^{-2}$		$1.18 \times 10^{-2}$		$7.14 \times 10^{-2}$	$1.18 \times 10^{-2}$	$4.98 \times 10^{-2}$	
	35L	$5.26 \times 10^{-2}$		$9.67 \times 10^{-3}$		$5.26 \times 10^{-2}$	$9.67 \times 10^{-3}$	$4.98 \times 10^{-2}$	
	35SL	$4.40 \times 10^{-2}$		$8.34 \times 10^{-3}$		$4.40 \times 10^{-2}$	$8.34 \times 10^{-3}$	$4.98 \times 10^{-2}$	
	45	$5.49 \times 10^{-2}$		$9.58 \times 10^{-3}$		$5.49 \times 10^{-2}$	$9.58 \times 10^{-3}$	$3.85 \times 10^{-2}$	
	45L	$4.18 \times 10^{-2}$		$7.93 \times 10^{-3}$		$4.18 \times 10^{-2}$	$7.93 \times 10^{-3}$	$3.85 \times 10^{-2}$	
	45SL	$3.28 \times 10^{-2}$		$6.56 \times 10^{-3}$		$3.28 \times 10^{-2}$	$6.56 \times 10^{-3}$	$3.85 \times 10^{-2}$	
	55	$4.56 \times 10^{-2}$		$8.04 \times 10^{-3}$		$4.56 \times 10^{-2}$	$8.04 \times 10^{-3}$	$3.25 \times 10^{-2}$	
	55L	$3.37 \times 10^{-2}$		$6.42 \times 10^{-3}$		$3.37 \times 10^{-2}$	$6.42 \times 10^{-3}$	$3.25 \times 10^{-2}$	
	55SL	$2.56 \times 10^{-2}$		$5.22 \times 10^{-3}$		$2.56 \times 10^{-2}$	$5.22 \times 10^{-3}$	$3.25 \times 10^{-2}$	
	65	$3.54 \times 10^{-2}$		$6.06 \times 10^{-3}$		$3.54 \times 10^{-2}$	$6.06 \times 10^{-3}$	$2.70 \times 10^{-2}$	
	65L	$2.63 \times 10^{-2}$		$4.97 \times 10^{-3}$		$2.63 \times 10^{-2}$	$4.97 \times 10^{-3}$	$2.70 \times 10^{-2}$	
65SL	$1.97 \times 10^{-2}$		$4.01 \times 10^{-3}$		$1.97 \times 10^{-2}$	$4.01 \times 10^{-3}$	$2.70 \times 10^{-2}$		
SRW	70	$4.18 \times 10^{-2}$		$7.93 \times 10^{-3}$		$4.18 \times 10^{-2}$	$7.93 \times 10^{-3}$	$2.52 \times 10^{-2}$	
	85	$3.37 \times 10^{-2}$		$6.42 \times 10^{-3}$		$3.37 \times 10^{-2}$	$6.42 \times 10^{-3}$	$2.09 \times 10^{-2}$	
	100	$2.63 \times 10^{-2}$		$4.97 \times 10^{-3}$		$2.63 \times 10^{-2}$	$4.97 \times 10^{-3}$	$1.77 \times 10^{-2}$	
	130	$2.19 \times 10^{-2}$		$4.15 \times 10^{-3}$		$2.19 \times 10^{-2}$	$4.15 \times 10^{-3}$	$1.33 \times 10^{-2}$	
	150	$1.95 \times 10^{-2}$		$3.67 \times 10^{-3}$		$1.95 \times 10^{-2}$	$3.67 \times 10^{-3}$	$1.15 \times 10^{-2}$	

$K_{AR1}$  : Equivalent factor in the  $M_A$  radial direction when one LM block is used

$K_{AL1}$  : Equivalent factor in the  $M_A$  reverse radial direction when one LM block is used

$K_{AR2}$  : Equivalent factor in the  $M_A$  radial direction when two

LM blocks are used in close contact with each other

$K_{AL2}$  : Equivalent factor in the  $M_A$  reverse radial direction when two LM blocks are used in close contact with each other

$K_{B1}$  :  $M_B$  Equivalent factor when one LM block is used

$K_{B2}$  :  $M_B$  Equivalent factor when two LM blocks are used in close contact with each other

$K_{CR}$  : Equivalent factor in the  $M_C$  radial direction

$K_{CL}$  : Equivalent factor in the  $M_C$  reverse radial direction

## [Double-axis Use]

## ● Setting Conditions

Set the conditions needed to calculate the LM system's applied load and service life in hours.

The conditions consist of the following items.

- (1) Mass:  $m$  (kg)
- (2) Direction of the working load
- (3) Position of the working point (e.g., center of gravity):  $l_2, l_3, h_1$ (mm)
- (4) Thrust position:  $l_4, h_2$ (mm)
- (5) LM system arrangement:  $l_0, l_1$ (mm)  
(No. of units and axes)

- (6) Velocity diagram

Speed:  $V$  (mm/s)

Time constant:  $t_n$  (s)

Acceleration:  $\alpha_n$ (mm/s<sup>2</sup>)

$$(\alpha_n = \frac{V}{t_n} )$$

- (7) Duty cycle

Number of reciprocations per minute:  $N_1$ (min<sup>-1</sup>)

- (8) Stroke length:  $l_s$ (mm)

- (9) Average speed:  $V_m$ (m/s)

- (10) Required service life in hours:  $L_h$ (h)

Gravitational acceleration  $g=9.8$  (m/s<sup>2</sup>)

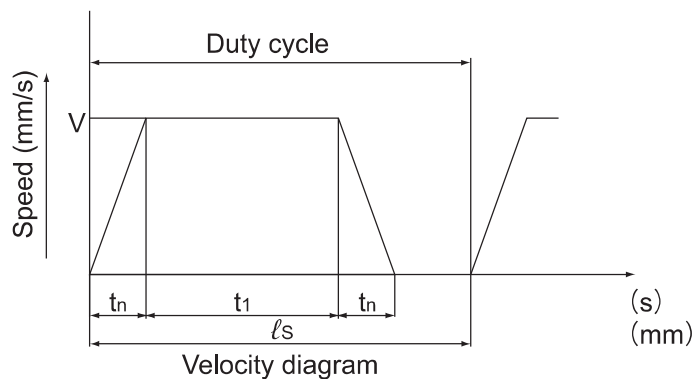
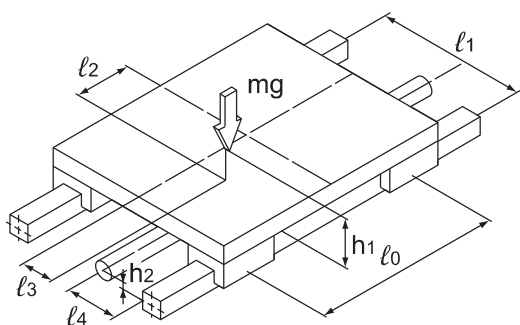

Fig.6 Condition

### ● Applied Load Equation

The load applied to the LM Guide varies with the external force, such as the position of the gravity center of an object, thrust position, inertia generated from acceleration/deceleration during start or stop, and cutting force.

In selecting an LM Guide, it is necessary to obtain the value of the applied load while taking into account these conditions.

Calculate the load applied to the LM Guide in each of the examples 1 to 10 shown below.

$m$	: Mass	(kg)
$l_n$	: Distance	(mm)
$F_n$	: External force	(N)
$P_n$	: Applied load (radial/reverse radial direction)	(N)
$P_{nT}$	: Applied load (lateral directions)	(N)
$g$	: Gravitational acceleration	(m/s <sup>2</sup> )
	( $g = 9.8\text{m/s}^2$ )	
$V$	: Speed	(m/s)
$t_n$	: Time constant	(s)
$\alpha_n$	: Acceleration	(m/s <sup>2</sup> )

$$(\alpha_n = \frac{V}{t_n})$$

### [Example]

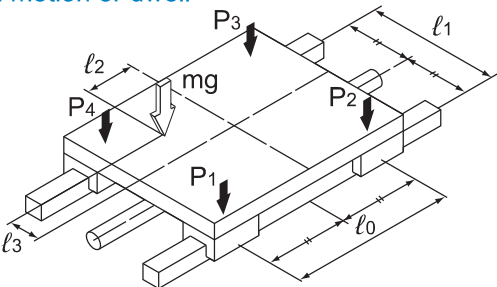
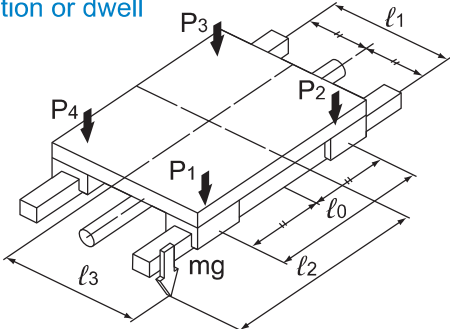
	Condition	Applied Load Equation
1	Horizontal mount (with the block traveling) Uniform motion or dwell 	$P_1 = \frac{mg}{4} + \frac{mg \cdot l_2}{2 \cdot l_0} - \frac{mg \cdot l_3}{2 \cdot l_1}$ $P_2 = \frac{mg}{4} - \frac{mg \cdot l_2}{2 \cdot l_0} - \frac{mg \cdot l_3}{2 \cdot l_1}$ $P_3 = \frac{mg}{4} - \frac{mg \cdot l_2}{2 \cdot l_0} + \frac{mg \cdot l_3}{2 \cdot l_1}$ $P_4 = \frac{mg}{4} + \frac{mg \cdot l_2}{2 \cdot l_0} + \frac{mg \cdot l_3}{2 \cdot l_1}$
2	Horizontal mount, overhung (with the block traveling) Uniform motion or dwell 	$P_1 = \frac{mg}{4} + \frac{mg \cdot l_2}{2 \cdot l_0} + \frac{mg \cdot l_3}{2 \cdot l_1}$ $P_2 = \frac{mg}{4} - \frac{mg \cdot l_2}{2 \cdot l_0} + \frac{mg \cdot l_3}{2 \cdot l_1}$ $P_3 = \frac{mg}{4} - \frac{mg \cdot l_2}{2 \cdot l_0} - \frac{mg \cdot l_3}{2 \cdot l_1}$ $P_4 = \frac{mg}{4} + \frac{mg \cdot l_2}{2 \cdot l_0} - \frac{mg \cdot l_3}{2 \cdot l_1}$

Note) Load is positive in the direction of the arrow.

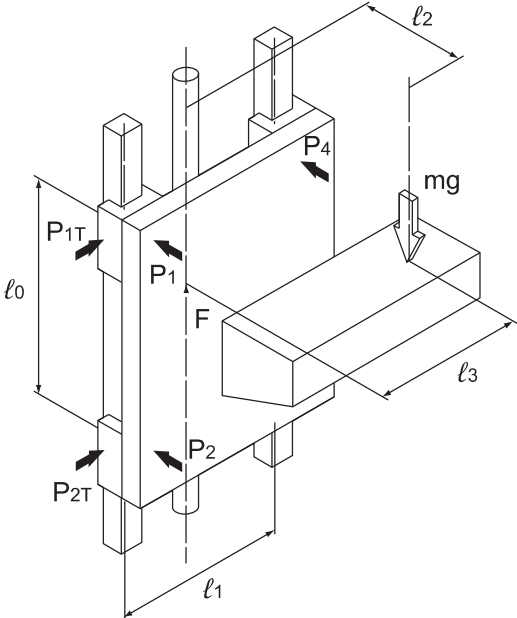
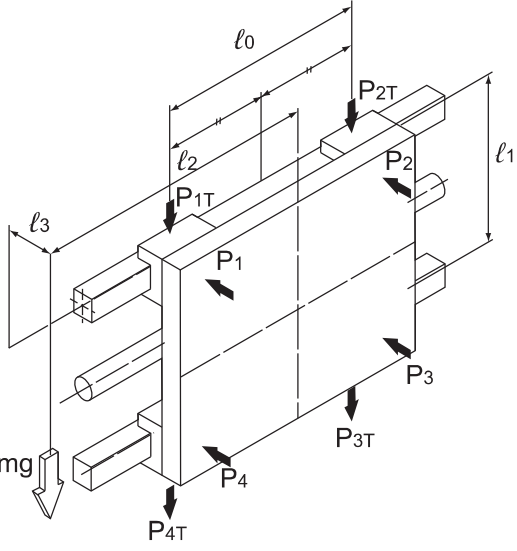
	Condition	Applied Load Equation
3	<p><b>Vertical mount</b> <b>Uniform motion or dwell</b></p>  <p>E.g.: Vertical axis of industrial robot, automatic coating machine, lifter</p>	$P_1 = P_4 = - \frac{mg \cdot l_2}{2 \cdot l_0}$ $P_2 = P_3 = \frac{mg \cdot l_2}{2 \cdot l_0}$ $P_{1T} = P_{4T} = \frac{mg \cdot l_3}{2 \cdot l_0}$ $P_{2T} = P_{3T} = - \frac{mg \cdot l_3}{2 \cdot l_0}$
4	<p><b>Wall mount</b> <b>Uniform motion or dwell</b></p>  <p>E.g.: Travel axis of cross-rail loader</p>	$P_1 = P_2 = - \frac{mg \cdot l_3}{2 \cdot l_1}$ $P_3 = P_4 = \frac{mg \cdot l_3}{2 \cdot l_1}$ $P_{1T} = P_{4T} = \frac{mg}{4} + \frac{mg \cdot l_2}{2 \cdot l_0}$ $P_{2T} = P_{3T} = \frac{mg}{4} - \frac{mg \cdot l_2}{2 \cdot l_0}$

Note) Load is positive in the direction of the arrow.

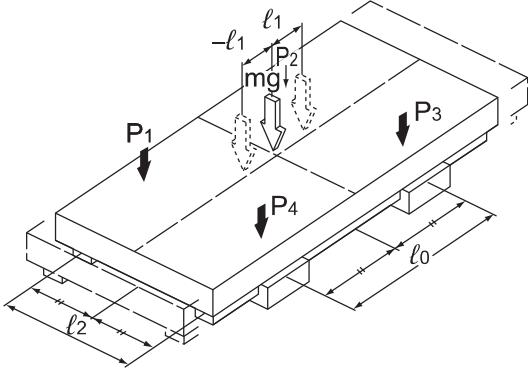
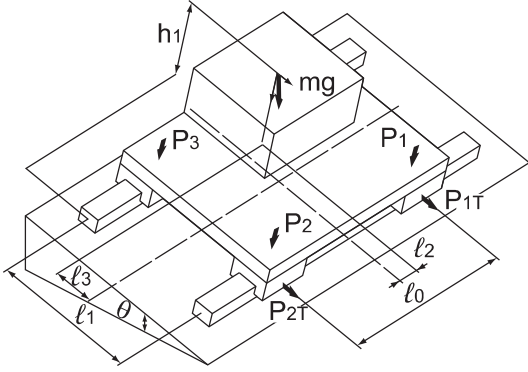
	Condition	Applied Load Equation
5	<p><b>With the LM rails movable</b> <b>Horizontal mount</b></p>  <p>E.g.: XY table sliding fork</p>	$P_1 \text{ to } P_4 (\text{max}) = \frac{mg}{4} + \frac{mg \cdot l_1}{2 \cdot l_0}$ $P_1 \text{ to } P_4 (\text{min}) = \frac{mg}{4} - \frac{mg \cdot l_1}{2 \cdot l_0}$
6	<p><b>Laterally tilt mount</b></p>  <p>E.g.: NC lathe Carriage</p>	$P_1 = + \frac{mg \cdot \cos \theta}{4} + \frac{mg \cdot \cos \theta \cdot l_2}{2 \cdot l_0}$ $- \frac{mg \cdot \cos \theta \cdot l_3}{2 \cdot l_1} + \frac{mg \cdot \sin \theta \cdot h_1}{2 \cdot l_1}$ $P_{1T} = \frac{mg \cdot \sin \theta}{4} + \frac{mg \cdot \sin \theta \cdot l_2}{2 \cdot l_0}$ $P_2 = + \frac{mg \cdot \cos \theta}{4} - \frac{mg \cdot \cos \theta \cdot l_2}{2 \cdot l_0}$ $- \frac{mg \cdot \cos \theta \cdot l_3}{2 \cdot l_1} + \frac{mg \cdot \sin \theta \cdot h_1}{2 \cdot l_1}$ $P_{2T} = \frac{mg \cdot \sin \theta}{4} - \frac{mg \cdot \sin \theta \cdot l_2}{2 \cdot l_0}$ $P_3 = + \frac{mg \cdot \cos \theta}{4} - \frac{mg \cdot \cos \theta \cdot l_2}{2 \cdot l_0}$ $+ \frac{mg \cdot \cos \theta \cdot l_3}{2 \cdot l_1} - \frac{mg \cdot \sin \theta \cdot h_1}{2 \cdot l_1}$ $P_{3T} = \frac{mg \cdot \sin \theta}{4} - \frac{mg \cdot \sin \theta \cdot l_2}{2 \cdot l_0}$ $P_4 = + \frac{mg \cdot \cos \theta}{4} + \frac{mg \cdot \cos \theta \cdot l_2}{2 \cdot l_0}$ $+ \frac{mg \cdot \cos \theta \cdot l_3}{2 \cdot l_1} - \frac{mg \cdot \sin \theta \cdot h_1}{2 \cdot l_1}$ $P_{4T} = \frac{mg \cdot \sin \theta}{4} + \frac{mg \cdot \sin \theta \cdot l_2}{2 \cdot l_0}$

Note) Load is positive in the direction of the arrow.

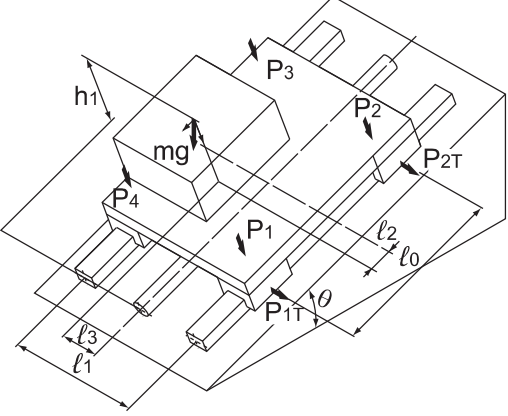
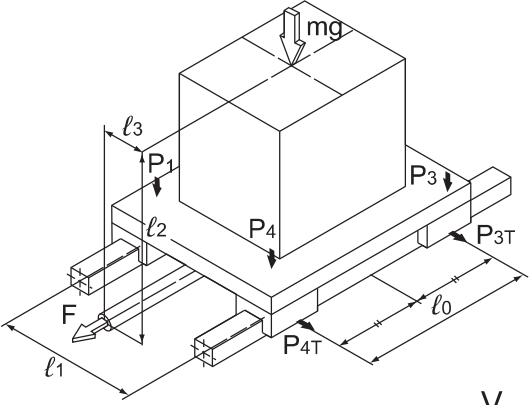
	Condition	Applied Load Equation
7	<p><b>Longitudinally tilt mount</b></p>  <p>E.g.: NC lathe Tool rest</p>	$P_1 = + \frac{mg \cdot \cos\theta}{4} + \frac{mg \cdot \cos\theta \cdot l_2}{2 \cdot l_0}$ $- \frac{mg \cdot \cos\theta \cdot l_3}{2 \cdot l_1} + \frac{mg \cdot \sin\theta \cdot h_1}{2 \cdot l_0}$ $P_{1T} = + \frac{mg \cdot \sin\theta \cdot l_3}{2 \cdot l_0}$ $P_2 = + \frac{mg \cdot \cos\theta}{4} - \frac{mg \cdot \cos\theta \cdot l_2}{2 \cdot l_0}$ $- \frac{mg \cdot \cos\theta \cdot l_3}{2 \cdot l_1} - \frac{mg \cdot \sin\theta \cdot h_1}{2 \cdot l_0}$ $P_{2T} = - \frac{mg \cdot \sin\theta \cdot l_3}{2 \cdot l_0}$ $P_3 = + \frac{mg \cdot \cos\theta}{4} - \frac{mg \cdot \cos\theta \cdot l_2}{2 \cdot l_0}$ $+ \frac{mg \cdot \cos\theta \cdot l_3}{2 \cdot l_1} - \frac{mg \cdot \sin\theta \cdot h_1}{2 \cdot l_0}$ $P_{3T} = - \frac{mg \cdot \sin\theta \cdot l_3}{2 \cdot l_0}$ $P_4 = + \frac{mg \cdot \cos\theta}{4} + \frac{mg \cdot \cos\theta \cdot l_2}{2 \cdot l_0}$ $+ \frac{mg \cdot \cos\theta \cdot l_3}{2 \cdot l_1} + \frac{mg \cdot \sin\theta \cdot h_1}{2 \cdot l_0}$ $P_{4T} = + \frac{mg \cdot \sin\theta \cdot l_3}{2 \cdot l_0}$
8	<p><b>Horizontal mount with inertia</b></p>  <p>Velocity diagram</p> <p>E.g.: Conveyance truck</p> $\alpha_n = \frac{V}{t_n}$	<p>During acceleration</p> $P_1 = P_4 = \frac{mg}{4} - \frac{m \cdot \alpha_1 \cdot l_2}{2 \cdot l_0}$ $P_2 = P_3 = \frac{mg}{4} + \frac{m \cdot \alpha_1 \cdot l_2}{2 \cdot l_0}$ $P_{1T} = P_{4T} = \frac{m \cdot \alpha_1 \cdot l_3}{2 \cdot l_0}$ $P_{2T} = P_{3T} = - \frac{m \cdot \alpha_1 \cdot l_3}{2 \cdot l_0}$ <p>During uniform motion</p> $P_1 \text{ to } P_4 = \frac{mg}{4}$ <p>During deceleration</p> $P_1 = P_4 = \frac{mg}{4} + \frac{m \cdot \alpha_3 \cdot l_2}{2 \cdot l_0}$ $P_2 = P_3 = \frac{mg}{4} - \frac{m \cdot \alpha_3 \cdot l_2}{2 \cdot l_0}$ $P_{1T} = P_{4T} = - \frac{m \cdot \alpha_3 \cdot l_3}{2 \cdot l_0}$ $P_{2T} = P_{3T} = \frac{m \cdot \alpha_3 \cdot l_3}{2 \cdot l_0}$

Note) Load is positive in the direction of the arrow.

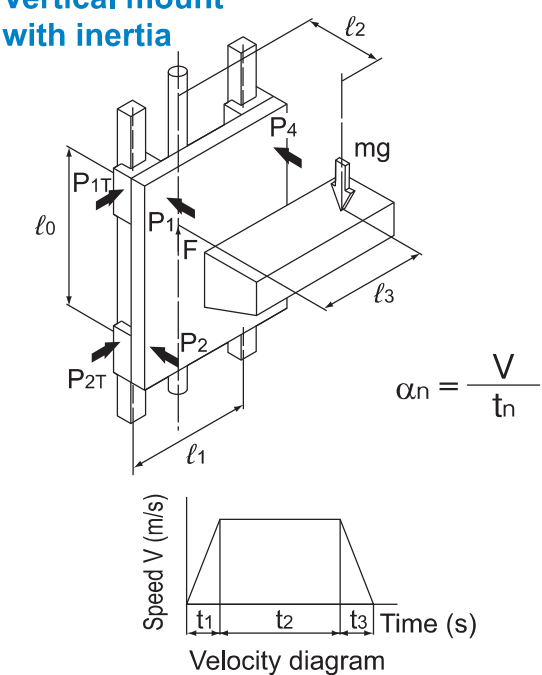
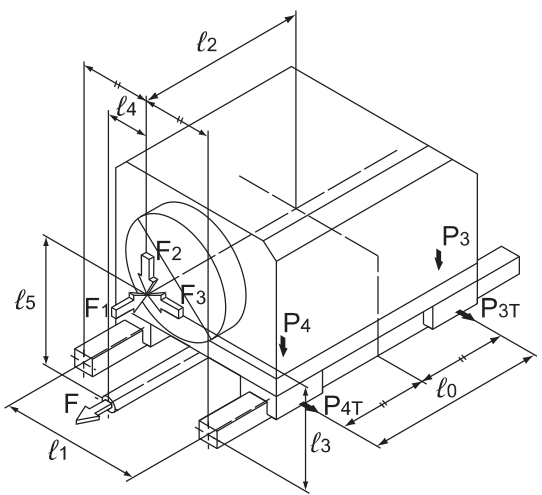
	Condition	Applied Load Equation
9	<p><b>Vertical mount with inertia</b></p>  <p style="text-align: center;"><math>\alpha_n = \frac{V}{t_n}</math></p> <p style="text-align: center;">Velocity diagram</p> <p style="text-align: center;">E.g.: Conveyance lift</p>	<p>During acceleration</p> $P_1 = P_4 = - \frac{m(g + \alpha_1)l_2}{2 \cdot l_0}$ $P_2 = P_3 = \frac{m(g + \alpha_1)l_2}{2 \cdot l_0}$ $P_{1T} = P_{4T} = \frac{m(g + \alpha_1)l_3}{2 \cdot l_0}$ $P_{2T} = P_{3T} = - \frac{m(g + \alpha_1)l_3}{2 \cdot l_0}$ <p>During uniform motion</p> $P_1 = P_4 = - \frac{mg \cdot l_2}{2 \cdot l_0}$ $P_2 = P_3 = \frac{mg \cdot l_2}{2 \cdot l_0}$ $P_{1T} = P_{4T} = \frac{mg \cdot l_3}{2 \cdot l_0}$ $P_{2T} = P_{3T} = - \frac{mg \cdot l_3}{2 \cdot l_0}$ <p>During deceleration</p> $P_1 = P_4 = - \frac{m(g - \alpha_3)l_2}{2 \cdot l_0}$ $P_2 = P_3 = \frac{m(g - \alpha_3)l_2}{2 \cdot l_0}$ $P_{1T} = P_{4T} = \frac{m(g - \alpha_3)l_3}{2 \cdot l_0}$ $P_{2T} = P_{3T} = - \frac{m(g - \alpha_3)l_3}{2 \cdot l_0}$
10	<p><b>Horizontal mount with external force</b></p>  <p style="text-align: center;">E.g.: Drill unit, Milling machine, Lathe, Machining center and other cutting machine</p>	<p>Under force F<sub>1</sub></p> $P_1 = P_4 = - \frac{F_1 \cdot l_5}{2 \cdot l_0}$ $P_2 = P_3 = \frac{F_1 \cdot l_5}{2 \cdot l_0}$ $P_{1T} = P_{4T} = \frac{F_1 \cdot l_4}{2 \cdot l_0}$ $P_{2T} = P_{3T} = - \frac{F_1 \cdot l_4}{2 \cdot l_0}$ <p>Under force F<sub>2</sub></p> $P_1 = P_4 = \frac{F_2}{4} + \frac{F_2 \cdot l_2}{2 \cdot l_0}$ $P_2 = P_3 = \frac{F_2}{4} - \frac{F_2 \cdot l_2}{2 \cdot l_0}$ <p>Under force F<sub>3</sub></p> $P_1 = P_2 = \frac{F_3 \cdot l_3}{2 \cdot l_1}$ $P_3 = P_4 = - \frac{F_3 \cdot l_3}{2 \cdot l_1}$ $P_{1T} = P_{4T} = - \frac{F_3}{4} - \frac{F_3 \cdot l_2}{2 \cdot l_0}$ $P_{2T} = P_{3T} = - \frac{F_3}{4} + \frac{F_3 \cdot l_2}{2 \cdot l_0}$

Note) Load is positive in the direction of the arrow.

# Calculating the Equivalent Load

## Rated Load of an LM Guide in Each Direction

The LM Guide is categorized into roughly two types: the 4-way equal load type, which has the same rated load in the radial, reverse radial and lateral directions, and the radial type, which has a large rated load in the radial direction. With the radial type LM Guide, the rated load in the radial direction is different from that in the reverse radial and lateral directions. The basic load rating in the radial direction is indicated in the specification table. The values in the reverse-radial and lateral directions are obtained from Table 7 on **A1-60**.

### [Rated Loads in All Directions]



Type	Load Distribution Curve
<p><b>4-way Equal Load Type</b></p> 	
<p><b>Radial Type</b></p> 	

Table7 Rated Loads in All Directions

Classification	Model No.		Reverse radial direction 		Lateral directions 	
	Type	Size	Dynamic load rating $C_L$	Static load rating $C_{0L}$	Dynamic load rating $C_T$	Static load rating $C_{0T}$
4-way Equal Load	SHS		C	$C_0$	C	$C_0$
	SHW		C	$C_0$	C	$C_0$
	SRS	12,15,25	C	$C_0$	C	$C_0$
	SCR		C	$C_0$	C	$C_0$
	EPF		C	$C_0$	C	$C_0$
	HSR		C	$C_0$	C	$C_0$
	NRS	75,85,100	C	$C_0$	C	$C_0$
	HRW	17,21,27,35,50,60	C	$C_0$	C	$C_0$
	RSX	12,15	C	$C_0$	C	$C_0$
	RSR	2,3	C	$C_0$	C	$C_0$
	CSR		C	$C_0$	C	$C_0$
	MX		C	$C_0$	C	$C_0$
	JR		C	$C_0$	C	$C_0$
	HCR		C	$C_0$	C	$C_0$
	HMG		C	$C_0$	C	$C_0$
	HSR-M1		C	$C_0$	C	$C_0$
	RSX-M1	12,15	C	$C_0$	C	$C_0$
	RSR-M1	9	C	$C_0$	C	$C_0$
	HSR-M2		C	$C_0$	C	$C_0$
	HSR-M1VV		C	$C_0$	C	$C_0$
	SRG		C	$C_0$	C	$C_0$
	SRN	35,45,55,65	C	$C_0$	C	$C_0$
SRW		C	$C_0$	C	$C_0$	
Radial	SSR		0.50C	0.50 $C_0$	0.53C	0.43 $C_0$
	SVR		0.64C	0.64 $C_0$	0.47C	0.38 $C_0$
	SR	15,20,25,30,35,45,55,70	0.62C	0.50 $C_0$	0.56C	0.43 $C_0$
	SR	85,100,120,150	0.78C	0.71 $C_0$	0.48C	0.35 $C_0$
	NR-X		0.64C	0.64 $C_0$	0.47C	0.38 $C_0$
	NR	75,85,100	0.78C	0.71 $C_0$	0.48C	0.45 $C_0$
	HRW	12,14	0.78C	0.71 $C_0$	0.48C	0.35 $C_0$
	NSR		0.62C	0.50 $C_0$	0.56C	0.43 $C_0$
	SR-M1		0.62C	0.50 $C_0$	0.56C	0.43 $C_0$
Other	SVS		0.84C	0.84 $C_0$	0.92C	0.85 $C_0$
	NRS-X		0.84C	0.84 $C_0$	0.92C	0.85 $C_0$
	SRS	5,7,9,20	C	$C_0$	1.19C	1.19 $C_0$
	RSX	5,7,9	C	$C_0$	1.19C	1.19 $C_0$
	RSR	14	0.78C	0.70 $C_0$	0.78C	0.71 $C_0$
	HR		C	$C_0$	C	$C_0$
	GSR		0.93C	0.90 $C_0$	(T) 0.84C* (C) 0.93C*	(T) 0.78 $C_0$ * (C) 0.90 $C_0$ *
	GSR-R		0.93C	0.90 $C_0$	(T) 0.84C* (C) 0.93C*	(T) 0.78 $C_0$ * (C) 0.90 $C_0$ *
	RSX-M1	9	C	$C_0$	1.19C	1.19 $C_0$
	RSR-M1	12,15,20	0.78C	0.70 $C_0$	0.78C	0.71 $C_0$

\*(T): Tensile lateral direction; (C): Compressive lateral direction  
 Note) C and  $C_0$  in the table each represent the basic load rating indicated in the specification table of the respective model.  $F_0$  represents the permissible load. For types with no size indication in the table, the same factor is applied to all sizes. Models HR, GSR and GSR-R cannot be used in single-axis applications.

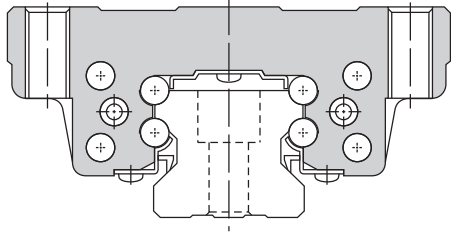
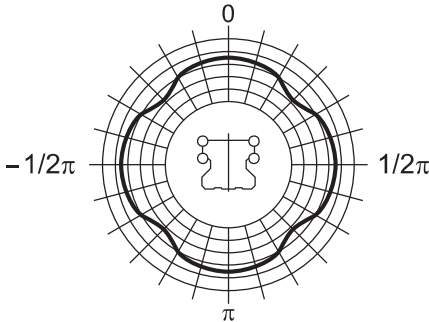
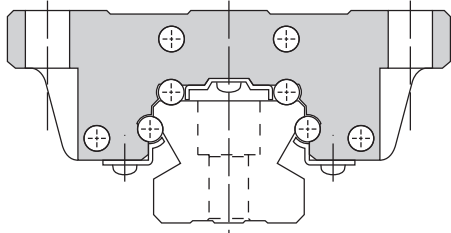
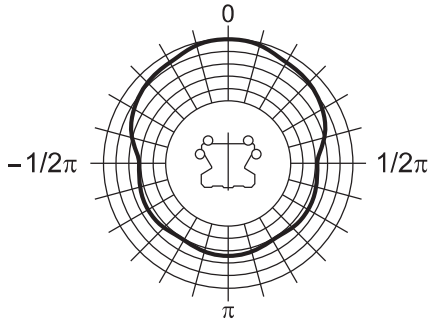

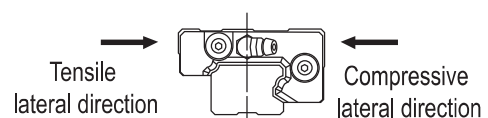
## Point of Selection

### Calculating the Equivalent Load

#### [Equivalent Load $P_E$ ]

The LM Guide can bear loads and moments in all directions, including a radial load (PR), reverse radial load (PL) and lateral loads (PT), simultaneously.

When two or more loads (e.g., radial load and lateral load) are simultaneously applied to the LM Guide, the service life and the static safety factor are calculated using equivalent load values obtained by converting all the loads into radial load or reverse radial load.

#### [Equivalent Load Equation]

When the LM block of the LM Guide receives loads simultaneously in the radial and lateral directions, or the reverse radial and lateral directions, the equivalent load is obtained from the equation below.

$$P_E = X \cdot P_{R(L)} + Y \cdot P_T$$

$P_E$	: Equivalent load	(N)
	·Radial direction	
	·Reverse radial direction	
$P_L$	: Reverse radial load	(N)
$P_T$	: Lateral load	(N)
X, Y	: Equivalent factor	(see Table8)

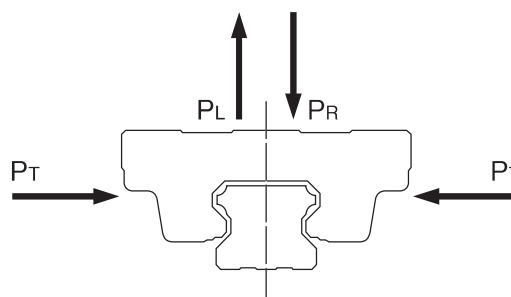

Fig.7 Equivalent of Load of the LM Guide

Table8 Equivalent Factor in Each Direction

Classification	Model No.		If radial and lateral loads are applied simultaneously		If reverse-radial and lateral loads are applied simultaneously	
			Equivalent in radial direction		Equivalent in reverse radial direction	
	Type	Size	X	Y	X	Y
4-way Equal Load	SHS		1.000	1.000	1.000	1.000
	SHW		1.000	1.000	1.000	1.000
	SRS	12,15,25	1.000	1.000	1.000	1.000
	SCR		1.000	1.000	1.000	1.000
	EPF		1.000	1.000	1.000	1.000
	HSR		1.000	1.000	1.000	1.000
	NRS	75,85,100	1.000	1.000	1.000	1.000
	HRW	17,21,27,35,50,60	1.000	1.000	1.000	1.000
	RSX	12,15	1.000	1.000	1.000	1.000
	RSR	2,3	1.000	1.000	1.000	1.000
	CSR		1.000	1.000	1.000	1.000
	MX		1.000	1.000	1.000	1.000
	JR		1.000	1.000	1.000	1.000
	HCR		1.000	1.000	1.000	1.000
	HMG		1.000	1.000	1.000	1.000
	HSR-M1		1.000	1.000	1.000	1.000
	RSX-M1	12,15	1.000	1.000	1.000	1.000
	RSR-M1	9	1.000	1.000	1.000	1.000
	HSR-M2		1.000	1.000	1.000	1.000
	HSR-M1VV		1.000	1.000	1.000	1.000
SRG		1.000	1.000	1.000	1.000	
SRN		1.000	1.000	1.000	1.000	
SRW		1.000	1.000	1.000	1.000	
Radial	SSR		—	—	1.000	1.155
	SVR		—	—	1.000	1.678
	SR	15,20,25,30,35,45,55,70	—	—	1.000	1.155
	SR	85,100,120,150	—	—	1.000	2.000
	NR-X		—	—	1.000	1.678
	NR	75,85,100	—	—	1.000	2.000
	HRW	12,14	—	—	1.000	2.000
	NSR		—	—	1.000	1.155
	SR-M1		—	—	1.000	1.155
Other	SVS		1.000	0.935	1.000	1.020
	NRS-X		1.000	0.935	1.000	1.020
	SRS	5,7,9,20	1.000	0.839	1.000	0.839
	RSX	5,7,9	1.000	0.839	1.000	0.839
	RSR	14	1.000	0.830	1.000	0.990
	HR		1.000	0.500	1.000	0.500
	GSR		1.000	1.280	1.000	1.000
	GSR-R		1.000	1.280	1.000	1.280
	RSX-M1	9	1.000	0.839	1.000	0.839
	RSR-M1	12,15,20	1.000	0.830	1.000	0.990

Note) If the radial type LM Guide receives radial and lateral loads simultaneously, study the safety static factor and the rated load in the radial-load and lateral-load directions.

For types with no size indication in the table, the same factor is applied to all sizes.

Models HR, GSR and GSR-R cannot be used in single-axis applications.

## Calculating the Static Safety Factor

To calculate a load applied to the LM Guide, the average load required for calculating the service life and the maximum load needed for calculating the static safety factor must be obtained first. In a system subject to frequent starts and stops, placed under cutting forces or under a large moment caused by an overhang load, an excessively large load may apply to the LM Guide. When selecting a model number, make sure that the desired model is capable of receiving the required maximum load (whether stationary or in motion). Table9 shows reference values for the static safety factor.

Table9 Reference Values for the Static Safety Factor ( $f_s$ )

Machine using the LM Guide	Load conditions	Lower limit of $f_s$
General industrial machinery	Without vibration or impact	1.0 to 3.5
	With vibration or impact	2.0 to 5.0
Machine tool	Without vibration or impact	1.0 to 4.0
	With vibration or impact	2.5 to 7.0

When the radial load is large	$\frac{f_H \cdot f_T \cdot f_C \cdot C_0}{P_R} \geq f_s$
When the reverse radial load is large	$\frac{f_H \cdot f_T \cdot f_C \cdot C_{0L}}{P_L} \geq f_s$
When the lateral loads are large	$\frac{f_H \cdot f_T \cdot f_C \cdot C_{0T}}{P_T} \geq f_s$

- $f_s$  : Static safety factor
- $C_0$  : Basic static load rating  
(radial direction) (N)
- $C_{0L}$  : Basic static load rating  
(reverse-radial direction) (N)
- $C_{0T}$  : Basic static load rating  
(lateral direction) (N)
- $P_R$  : Calculated load (radial direction) (N)
- $P_L$  : Calculated load  
(reverse-radial direction) (N)
- $P_T$  : Calculated load (lateral direction) (N)
- $f_H$  : Hardness factor (see Fig.8 on **A1-68**)
- $f_T$  : Temperature factor (see Fig.9 on **A1-68**)
- $f_C$  : Contact factor (see Table10 on **A1-68**)

## Calculating the Average Load

In cases where the load applied to each LM block fluctuates under different conditions, such as an industrial robot holding a work with its arm as it advances and receding with its arm empty, and a machine tool handling various workpieces, it is necessary to calculate the service life of the LM Block while taking into account such fluctuating loading conditions.

The average load ( $P_m$ ) is the load under which the service life of the LM Guide is equivalent to that under varying loads applied to the LM blocks.

$$P_m = \sqrt[i]{\frac{1}{L} \cdot \sum_{n=1}^n (P_n^i \cdot L_n)}$$

$P_m$  : Average Load (N)

$P_n$  : Varying load (N)

$L$  : Total travel distance (mm)

$L_n$  : Distance traveled under load  $P_n$  (mm)

$i$  : Constant determined by rolling element

Note) The above equation or the equation (1) below applies when the rolling elements are balls.

(1) When the load fluctuates stepwise

LM Guide Using Balls ( $i=3$ )

$$P_m = \sqrt[3]{\frac{1}{L} (P_1^3 \cdot L_1 + P_2^3 \cdot L_2 \cdots + P_n^3 \cdot L_n)} \cdots \cdots (1)$$

$P_m$  : Average load (N)

$P_n$  : Varying load (N)

$L$  : Total travel distance (mm)

$L_n$  : Distance traveled under  $P_n$  (mm)

LM Guide Using Rollers ( $i = \frac{10}{3}$ )

$$P_m = \sqrt[\frac{10}{3}]{\frac{1}{L} (P_1^{\frac{10}{3}} \cdot L_1 + P_2^{\frac{10}{3}} \cdot L_2 \cdots + P_n^{\frac{10}{3}} \cdot L_n)} \cdots \cdots (2)$$

$P_m$  : Average Load (N)

$P_n$  : Varying load (N)

$L$  : Total travel distance (mm)

$L_n$  : Distance traveled under  $P_n$  (mm)

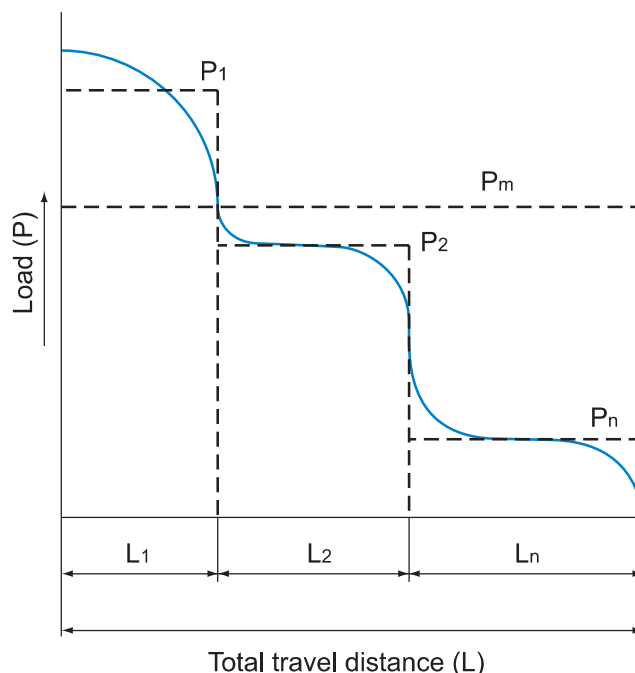

(2) When the load fluctuates monotonically

$$P_m \doteq \frac{1}{3} (P_{\min} + 2 \cdot P_{\max}) \dots\dots\dots(3)$$

$P_{\min}$  : Minimum load (N)

$P_{\max}$  : Maximum load (N)

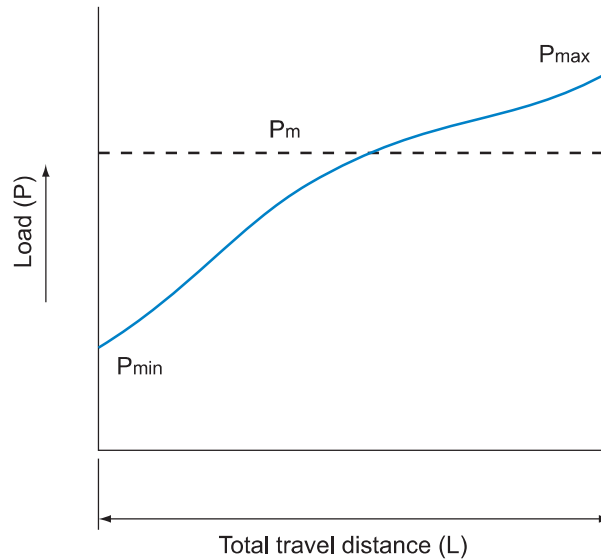

(3) When the load fluctuates sinusoidally

(a)  $P_m \doteq 0.65P_{\max} \dots\dots\dots(4)$

(b)  $P_m \doteq 0.75P_{\max} \dots\dots\dots(5)$

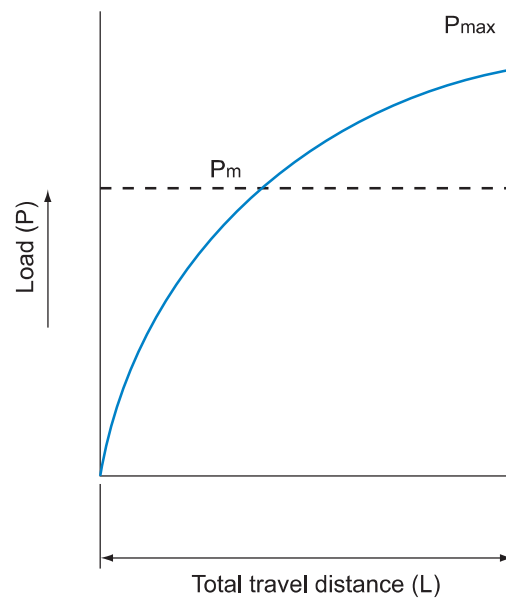
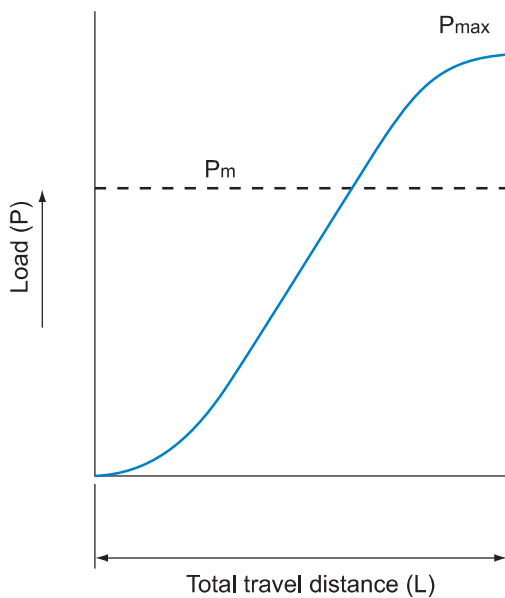

## Calculating the Nominal Life

The service life of an LM Guide is subject to variations even under the same operational conditions. Therefore, it is necessary to use the nominal life defined below as a reference value for obtaining the service life of the LM Guide. The nominal life means the total travel distance that 90% of a group of units of the same LM Guide model can achieve without flaking (scale-like pieces on the metal surface) after individually running under the same conditions.

---

### Calculating the Nominal Life

---

The nominal life ( $L_{10}$ ) of an LM Guide is obtained from the following formulas using the basic dynamic load rating ( $C$ ), which is based on a reference distance of 50 km for an LM Guide with balls and 100 km for an LM Guide with rollers, and the calculated load acting on the LM Guide ( $P_c$ ).

- LM Guide with balls (Using a basic dynamic load rating based on a nominal life of 50 km)

$$L_{10} = \left( \frac{C}{P_c} \right)^3 \times 50 \dots\dots\dots(1)$$

$L_{10}$	: Nominal life	(km)
$C$	: Basic dynamic load rating	(N)
$P_c$	: Calculated load	(N)

- LM Guide with rollers (Using a basic dynamic load rating based on a nominal life of 100 km)

$$L_{10} = \left( \frac{C}{P_c} \right)^{\frac{10}{3}} \times 100 \dots\dots\dots(2)$$

\* These nominal life formulas may not apply if the length of the stroke is less than or equal to twice the length of the LM block.

When comparing the nominal life ( $L_{10}$ ), you must take into account whether the basic dynamic load rating was defined based on 50 km or 100 km. Convert the basic dynamic load rating based on ISO 14728-1 as necessary.

ISO-regulated basic dynamic load rating conversion formulas:

- LM Guide with balls

$$C_{100} = \frac{C_{50}}{1.26}$$

$C_{50}$  : Basic dynamic load rating based on a nominal life of 50 km

$C_{100}$  : Basic dynamic load rating based on a nominal life of 100 km

- LM Guide with rollers

$$C_{100} = \frac{C_{50}}{1.23}$$

## Calculating the Modified Nominal Life

During use, an LM Guide may be subjected to vibrations and shocks as well as fluctuating loads, which are difficult to detect. In addition, the surface hardness of the raceways, the operating temperature, and having LM blocks arranged directly behind one another will have a decisive impact on the service life. Taking these factors into account, the modified nominal life ( $L_{10m}$ ) can be calculated according to the following formulas (3) and (4).

- Modified factor  $\alpha$

$$\alpha = \frac{f_H \cdot f_T \cdot f_C}{f_W}$$

$\alpha$	: Modified factor	
$f_H$	: Hardness factor	(see Fig.8 on <b>A1-68</b> )
$f_T$	: Temperature factor	(see Fig.9 on <b>A1-68</b> )
$f_C$	: Contact factor	(see Table10 on <b>A1-68</b> )
$f_W$	: Load factor	(see Table11 on <b>A1-69</b> )

- Modified nominal life  $L_{10m}$

- LM Guide with balls

$$L_{10m} = \left( \alpha \times \frac{C}{P_C} \right)^3 \times 50 \dots\dots\dots (3)$$

$L_{10m}$	: Modified nominal life	(km)
$C$	: Basic dynamic load rating	(N)
$P_C$	: Calculated load	(N)

- LM Guide with rollers

$$L_{10m} = \left( \alpha \times \frac{C}{P_C} \right)^{\frac{10}{3}} \times 100 \dots\dots\dots (4)$$

Once the nominal life ( $L_{10}$ ) has been obtained, the service life time can be obtained using the following equation if the stroke length and the number of reciprocations are constant.

$$L_h = \frac{L_{10} \times 10^6}{2 \times l_s \times n_1 \times 60}$$

$L_h$	: Service life time	(h)
$l_s$	: Stroke length	(mm)
$n_1$	: Number of reciprocations per minute	(min <sup>-1</sup> )

**[f<sub>H</sub>: Hardness Factor]**

To ensure the achievement of the optimum load capacity of the LM Guide, the raceway hardness must be between 58 and 64 HRC.

If the hardness is lower than this range, the basic dynamic load rating and the basic static load rating decrease. Therefore, it is necessary to multiply each rating by the respective hardness factor ( $f_H$ ).

Since the LM Guide has sufficient hardness, the  $f_H$  value for the LM Guide is normally 1.0 unless otherwise specified.

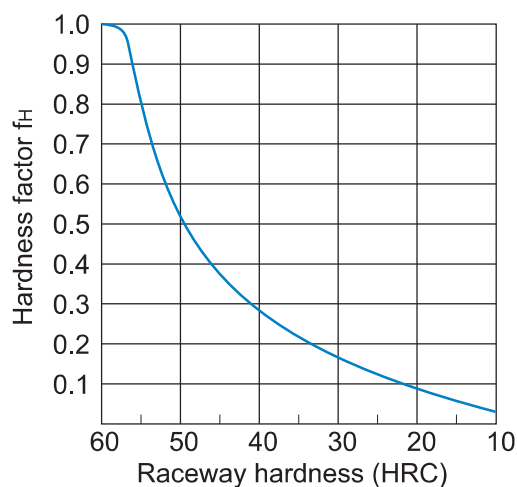
Fig.8 Hardness Factor ( $f_H$ )**[f<sub>T</sub>: Temperature Factor]**

If the temperature of the environment surrounding the operating LM Guide exceeds 100°C, take into account the adverse effect of the high temperature and multiply the basic load ratings by the temperature factor indicated in Fig.9.

In addition, the selected LM Guide must also be of a high temperature type.

Note) LM guides not designed to withstand high temperatures should be used at 80°C or less. Please contact THK if application requirements exceed 80°C.

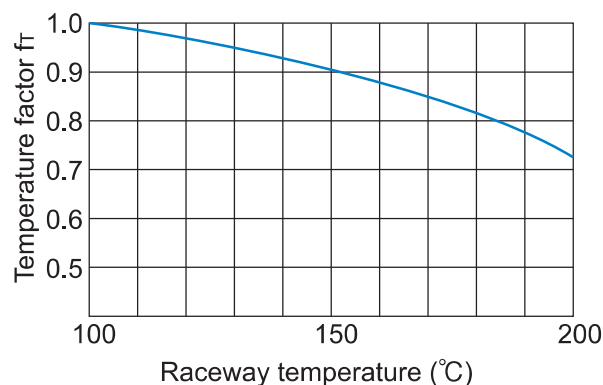
Fig.9 Temperature Factor ( $f_T$ )**[f<sub>c</sub>: Contact Factor]**

When multiple LM blocks are used in close contact with each other, it is difficult to achieve uniform load distribution due to moment loads and mounting-surface accuracy. When using multiple blocks in close contact with each other, multiply the basic load rating ( $C$  or  $C_0$ ) by the corresponding contact factor indicated in Table10.

Note) If uneven load distribution is expected in a large machine, take into account the respective contact factor indicated in Table10.

Table10 Contact Factor ( $f_c$ )

Number of blocks used in close contact	Contact factor $f_c$
2	0.81
3	0.72
4	0.66
5	0.61
6 or more	0.6
Normal use	1

## Point of Selection

### Calculating the Nominal Life

#### [ $f_w$ : Load Factor]

In general, reciprocating machines tend to involve vibrations or impact during operation. It is extremely difficult to accurately determine vibrations generated during high-speed operation and impact during frequent start and stop. Therefore, where the effects of speed and vibration are estimated to be significant, divide the basic dynamic load rating (C) by a load factor selected from Table11, which contains empirically obtained data.

Table11 Load Factor ( $f_w$ )

Vibrations/ impact	Speed (V)	$f_w$
Faint	Very low $V \leq 0.25\text{m/s}$	1 to 1.2
Weak	low $0.25 < V \leq 1\text{m/s}$	1.2 to 1.5
Medium	Medium $1 < V \leq 2\text{m/s}$	1.5 to 2
Strong	High $V > 2\text{m/s}$	2 to 3.5