

Cold applied low profile power connection

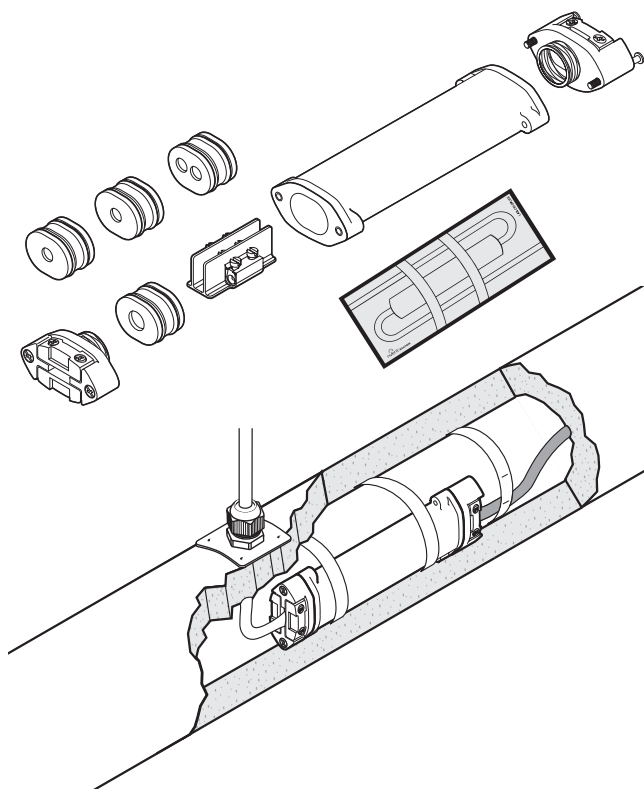

The nVent RAYCHEM CS-150-UNI-PI is a universal low profile heating cable connector for the direct connection of single conductor Polymer Insulated (PI) series heating cables. It can be used in different configurations: for the connection of a cold lead to a heating cable (Variant C), as an under insulation connecting system for the connection of a three core power cable to a heating cable loop (Variant L), as well as for splicing two heating cables (Variant S).

The connector is certified for use in hazardous areas and doesn't require a hot work permit. The electrical connection is realized by means of screw terminals, so no special crimp tools are required. If used as a connection kit, an additional gland needs to be ordered separately.

APPLICATION

"Cold" applied connection/splice for a single conductor polymer insulated (PI) series heating cables with an external diameter between 3.2 and 6.4 mm. In hazardous area use only with ATEX approved heating cable.

The CS-150-UNI-PI can be used in different configurations:

- Connection of a heating cable to a cold lead cable 1 x 2.5 mm² or 1 x 4 mm² (Variant C)
- Connection of a heating cable to a power cable 3 x 2.5 mm² (Variant L)
- Splice of two heating cables (Variant S)

KIT CONTENTS

- 1 x temperature resistant and impact proof body.
- 1 x screw terminal block
- 4 x rubber seals (to be used according to application)
- 2 x strain relieve clamps with screws
- 1 x identification label
- 1 x tube of lubricant
- 1 x installation instruction

APPROVALS

PTB 09 ATEX 1067U

II 2 G Ex eb IIC Gb

II 2 D Ex tb IIIC Db

IP66

IECEX PTB 09.0042U

Ex eb IIC Gb

Ex tb IIIC Db

IP66

TC RU C-BE.ИМ43.В.01854

ООО «ТехИмпорт»

Ambient temp range: -55°C...+180°C

Ex e II Gb U

Ex tb IIIC Db U

Made in USA



Ex e IIC Gb

Ex tD A21 IP66

Particular measures to maintain the T-classification of polymer insulated heating cables are to be taken in accordance with the appropriate EC - Type examination certificate (also refer to installation instructions).

Type examination certification applies for the use of ATEX certified polymer insulated (PI) series heating cables.

DIMENSIONS (IN MM)

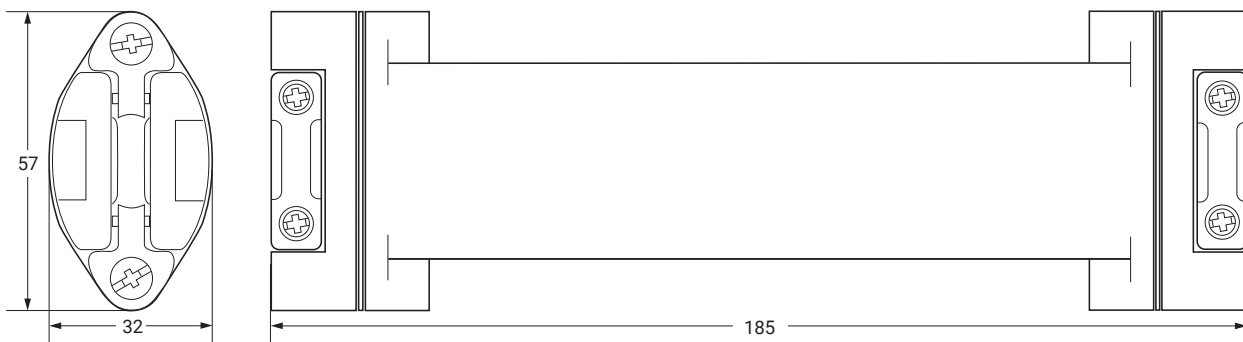

HEATING CABLE TYPES

Heating cable capability	XPI-F, XPI and XPI-S polymer insulated (PI) series resistance cable, for other types contact nVent.
--------------------------	---

MATERIALS OF CONSTRUCTION

Housing, connection	Glass fibre reinforced temperature resistant engineering plastic
Support ring, spacer, screws and spring	Stainless steel
Cable seals	Silicon rubber

MAXIMUM OPERATING TEMPERATURE (*)

Power on: 180°C (may be limited by the temperature resistance of the supply cable)

Power off: 200°C (using variant L, dependent on the type of supply cable e.g. 200°C for silicon cables, unless the power cable connection is bent sufficiently far away from the heated surface).

MINIMUM INSTALLATION TEMPERATURE

-50°C

MAX. OPERATING VOLTAGE

Variant C and S = 750 Vac

Variant L = 420 Vac

MAX. ALLOWED WATTAGE

The max. allowed cable output is limited depending on the application. Refer to the installation instruction for details.

MAX. ALLOWED WATTAGE

The max. allowed cable output is limited depending on the application. Refer to the installation instruction for details.

MAX. PERMITTED NOMINAL CURRENT (*)

Variant S: 32 A

Variant C with 1 x 2.5 mm² supply cable: 25 A

Variant C with 1 x 4 mm² supply cable: 32 A

Variant L with 3 x 2.5 mm² supply cable up to 150°C: 25 A

Variant L with 3 x 2.5 mm² supply cable 151°C to 180°C: 20 A

SUPPLY CABLE DIMENSIONS

-> Multi-stranded copper conductors 3 x 2.5 mm², Ø 7.8 -12.5 mm²

-> Single conductor cold lead, max. 1 x 4 mm², Ø 3.2 - 6.4 mm

SUPPLY CABLE REQUIREMENTS

The maximum permissible voltage drop is to be taken into consideration when selecting the cross-section of the power cable. The maximum working temperature of the CS-150-UNI-PI can be reduced through the maximum permitted continuous use temperature of the supply cable, unless the supply cable is laid (at a sufficient distance from the heated surface) so that the maximum permitted continuous use temperature will not be exceeded. A suitable power cable is the silicon insulated cable type C-150-PC.

ACCESSORIES

Cable gland	GL-55-M25 hazardous area approved gland for, 8-15mm, up to -55°C
Glands for PI heaters	C20-PI-PA-KIT Hazardous area approved gland, PA, up to -40°C
	C20-PI-M0-KIT Hazardous area approved gland, Ni plated brass, up to -55°C (to be used with boxes with integral earth plate or with earth lug)

ORDERING DETAILS

Order reference CS-150-UNI-PI

Part number (Weight) A45371-000 (0.4 kg)

(*) For the full range of technical design details of the CS-150-UNI-PI refer to the installation instructions (INSTALL-064)