



HENNLICH

MERES

RADAROVÝ HLADINOMĚR ECLIPSE® 706

DESCRIPTION

The Eclipse® Model 706 High Performance Transmitter is a loop-powered, 24 VDC level transmitter that is based upon the proven and accepted technology of Guided Wave Radar (GWR). Encompassing a number of significant engineering accomplishments, this leading edge level transmitter is designed to provide measurement performance well beyond that of many of the more traditional technologies.

Utilizing “diode switching” technology, along with the most comprehensive probe offering on the market, this single transmitter can be used in a wide variety of applications ranging from very light hydrocarbons to water-based media.

The innovative angled, dual compartment enclosure is now a common sight in the industry. This enclosure, first brought to the industry by Magnetrol® in 1998, is angled to maximize ease of wiring, configuration, and viewing of the versatile graphic LCD display.

One universal Model 706 transmitter can be used and interchanged with all probe types, and offers enhanced reliability as it is certified for use in critical SIL 2 hardware safety loops.

The ECLIPSE Model 706 supports both the FDT/DTM and Enhanced DD (EDDL) standards, which allow viewing of valuable configuration and diagnostic information such as the echo curve in tools such as PACTware™, AMS Device Manager, and various HART® Field Communicators.

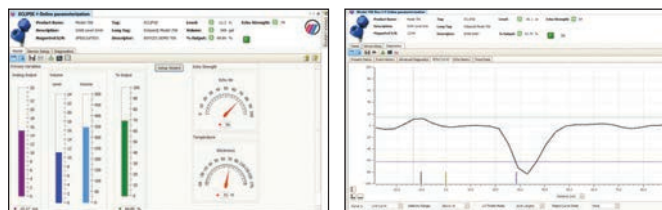

Eclipse® Model 706 DTM

Measures Level, Interface, Volume and Flow



APPLICATIONS

MEDIA: Liquids, solids, or slurries; hydrocarbons to water-based media (Dielectric Constant $\epsilon_r = 1.2-100$)

VESSELS: Most process or storage vessels up to rated probe temperature and pressure.

CONDITIONS: All level measurement and control applications including process conditions exhibiting visible vapors, foam, surface agitation, bubbling or boiling, high fill/empty rates, low level and varying dielectric media or specific gravity.

FEATURES

- Multivariable, two-wire, 24 VDC loop-powered transmitter for level, interface, volume, or flow.
- Unique adaptor allows operation with Model 705 probes
- Diode switching technology offers best-in-class signal strength and signal-to-noise ratio (SNR) resulting in enhanced capability in difficult low dielectric applications.
- Level measurement not affected by changing media characteristics.
- No need to move levels for calibration.
- Overflow Capable probes allow for “true level” measurement all the way up to the process seal, without the need for special algorithms.
- 4-button keypad and graphic LCD display allow for convenient viewing of configuration parameters and echo curve.
- Proactive diagnostics advise not only what is wrong, but also offer troubleshooting tips.
- Nine common tank shapes for volumetric output.
- 30-point custom strapping table for uncommonly-shaped tanks.
- Two standard flumes and four standard weirs of various sizes for flow measurement.
- Generic flow equation for non-standard channels.
- 360° rotatable housing can be separated from probe without depressurizing the vessel.
- Probe designs up to +450 °C/431 bar (+850 °F/ 6250 psi).
- Saturated steam applications up to 207 bar (3000 psi), +425 °C (+800 °F) when installed in side-mounted chamber.
- Cryogenic applications down to -196 °C (-320 °F).
- Transmitter can be remote-mounted up to 3,6 m (12 feet) away from the probe.
- SIL certification allows use in SIL 2/3 Loops.
- No moving parts.
- FOUNDATION Fieldbus™, PROFIBUS PA and Modbus digital outputs.
- Lloyd's Register steam drum approval

TECHNOLOGY

PRINCIPLE OF OPERATION

ECLIPSE Guided Wave Radar is based upon the technology of TDR (Time Domain Reflectometry). TDR utilizes pulses of electromagnetic energy transmitted down a wave guide (probe). When a pulse reaches a surface that has a higher dielectric constant than the air ($\epsilon_r = 1$) in which it is traveling, a portion of the pulse is reflected. The transit time of the pulse is then measured via high speed timing circuitry that provides an accurate measure of the liquid (or solids) level. The amplitude of the reflection depends on the dielectric constant of the product. The higher the dielectric constant, the larger is the reflection.

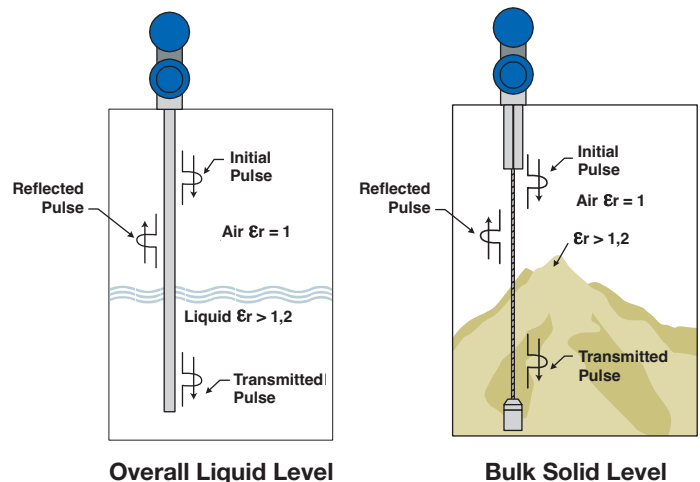

INTERFACE MEASUREMENT

The ECLIPSE Model 706 is capable of measuring both an upper liquid level and an interface liquid level. As only a portion of the pulse is reflected from a low dielectric upper surface, some of the transmitted energy continues down the GWR probe through the upper liquid. The remaining initial pulse is again reflected when it reaches the higher dielectric lower liquid. It is required that the upper liquid has a dielectric constant less than 10, and the lower liquid has a dielectric constant greater than 15. A typical interface application would be oil over water, with the upper layer of oil being non-conductive ($\epsilon_r \approx 2.0$), and the lower layer of water being very conductive ($\epsilon_r \approx 80$). The thickness of the upper layer could be as small as 50 mm (2") while the maximum upper layer is limited to the length of the GWR probe.

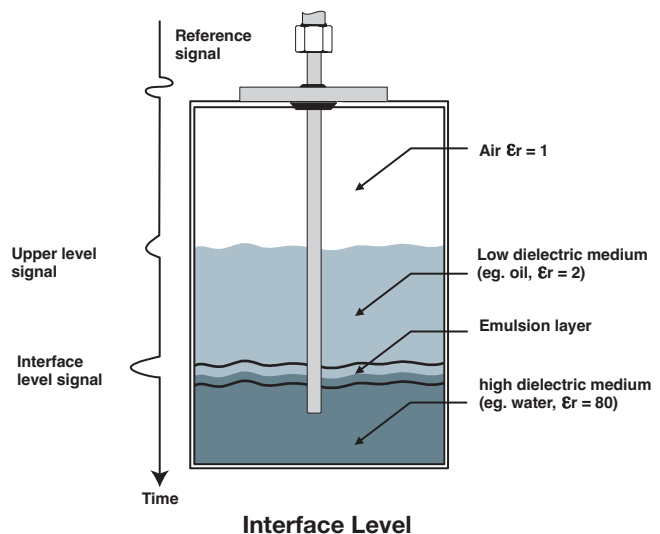

SPECIAL APPLICATIONS

EMULSION LAYERS

As emulsion layers, also called “rag layers” can decrease the strength of the reflected signal in an interface application, GWR transmitters are typically recommended for applications that have clean, distinct layers.

However, the ECLIPSE Model 706, with its powerful internal measurement algorithms, will tend to detect the top of an emulsion layer. Contact the factory for application assistance regarding emulsion layers in your specific application.

SATURATED STEAM APPLICATIONS (Boilers, Feedwater Heaters, etc.)

As the temperature of a saturated steam application increases, the dielectric constant of the steam vapor space also increases. This increase in vapor space dielectric causes a delay in the GWR signal propagation as it travels down the probe, causing the liquid level to appear lower than actual.

The ECLIPSE Model 706 transmitter and Model 7yS Coaxial Steam probe provide a unique solution to this application. The effects of the changing steam conditions can be compensated for by utilizing a mechanical steam target placed inside and near the top of the Model 7yS coaxial probe.

NOTE: The measurement error associated with this propagation delay does depend on temperature and is a function of the square root of the vapor space dielectric constant. For example, with no compensation, a +230 °C (+450 °F) application would show a level error of about 5.5 %, while a +315 °C (+600 °F) application would show an error approaching 20 %!

Knowing exactly where the target is located at room temperature, and then continuously monitoring its apparent location, the vapor space dielectric can be back-calculated. Knowing the vapor space dielectric, accurate compensation of the actual liquid level reading is accomplished.

This is a patented technique with two US Patents (US 6642801 and US 6867729) issued for both the mechanical target concept and the associated software algorithm.

Contact the factory for additional information relating to saturated steam applications.

In addition to vapor compensation, the standard Model 7yS Steam probe contains:

Only one bottom metal spacer

This eliminates the need for any spacers along the length of the probe, removing chemical compatibility concerns.

A unique (patent-pending) condensation tube design

This feature is very important in those high temperature applications where condensation can form in and around the probe, causing propagation delay issues.

An adjustable steam target location

This allows optimization of the vapor compensation based on the details of a specific application.

OVERFILL CAPABILITY

Although agencies like WHG or VLAREM certify **Overfill proof** protection, defined as the tested, reliable operation when the transmitter is used as overfill alarm, it is assumed in their analysis that the installation is designed in such a way that the vessel or side mounted cage cannot physically overfill.

However, there are practical applications where a GWR probe can be completely flooded with level all the way up to the process connection (face of the flange). Although the affected areas are application dependent, typical GWR probes have a transition zone (or possibly dead zone) at the top of the probe where interacting signals can either affect the linearity of the measurement or, more dramatically, result in a complete loss of signal.

While some manufacturers of GWR transmitters may use special algorithms to “infer” level measurement when this undesirable signal interaction occurs and the actual level signal is lost, the ECLIPSE Model 706 offers a unique solution by utilizing a concept called **Overfill Safe Operation**.

An **Overfill safe probe** is defined by the fact that it has a predictable and uniform characteristic impedance all the way down the entire length of the waveguide (probe). These probes allow the ECLIPSE Model 706 to measure accurate levels up to the process flange without any non-measurable zone at the top of the GWR probe.

Overfill safe GWR probes are unique to ECLIPSE GWR, and coaxial probes can be installed at any location on the vessel. Overfill safe probes are offered in a variety of Coaxial and Caged designs.

PROBE OVERVIEW

TWO STYLES OF GWR PROBES

With one basic ECLIPSE Model 706 transmitter that operates with all probes, choosing the proper Guided Wave Radar (GWR) probe is the most important decision in the application process. The probe configuration establishes fundamental performance characteristics.

All ECLIPSE Model 706 probes can be described by three basic configurations:

- Coaxial
- Single element (rigid rod or flexible cable)

Each of these probe configurations has specific strengths and weaknesses. Although there can be overlap, and different probes can certainly be used in similar applications, it is important to understand their basic differences so that one can choose the probe type that will offer optimal performance.

The descriptions below are facts relating to the physics of GWR technology and are not specific to the ECLIPSE Model 706.

COAXIAL PROBES

The coaxial probe is the most efficient of all GWR probe configurations and should be the first consideration in all applications. Analogous to the efficiency of coaxial cable, a coaxial probe allows almost unimpeded movement of the high frequency pulses throughout its length.

The electromagnetic field that develops between the inner rod and outer tube is completely contained and uniform down the entire length of the probe. See Figure 1. This means that the coaxial probe is immune to any proximity affects from other objects in the vessel, and therefore, in essence, it can be used anywhere that it can mechanically fit.

The efficiency and overall sensitivity of a coaxial configuration yields robust signal strength, even in extremely low dielectric ($\epsilon_r \geq 1.4$) applications. The sensitivity of this “closed” design, however, also makes it more susceptible to measurement error in applications that can have coating and buildup.

All ECLIPSE Model 706 coaxial probes are Overfill Safe as standard, by design.

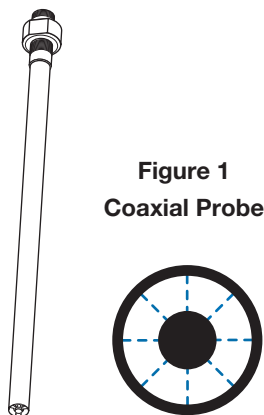

Figure 1
Coaxial Probe

BASIC-FOR CLEAN LIQUIDS

The basic 22,5 mm (0.875") diameter coaxial GWR probe is only recommended for use in clean applications or special applications such as saturated steam. Teflon®, PEEK, or alumina spacers centering the inner rod within the outer tube are located at 60 cm (24") intervals, resulting in a perfect characteristic impedance along the entire length of the probe.

This probe is recommended in applications with viscosities up to 500 cP (mPa.s) maximum.

ENLARGED-FOR DIFFICULT LIQUIDS

The standard Enlarged 45 mm (1.75") or 49 mm (1.93") diameter coaxial GWR probes can be generally used for most applications. They can be installed directly into the tank as well as into bypass cages, stillwells or bridges.

The robust construction reduces the number of spacers required, allowing the probe to be used in applications where higher risk of buildup exists. To further reduce the possibility of media buildup, the use of a single bottom spacer is recommended up to probe lengths of 2.54 m (100"). The overall sensitivity and performance of an enlarged coaxial GWR probe is identical to a standard coaxial GWR probe, but it offers the very important advantage that it can be used in applications with viscosities up to 2,000 cP (mPa.s).

OPTIONAL FLUSHING CONNECTION

The maintenance of coaxial GWR probes in applications suffering from buildup or crystallization can be significantly improved by using an optional flushing connection. This flushing connection is a metal extension with a port welded above the process connection. The port allows the user to purge the inside of the coaxial GWR probe during routine maintenance.

Note: The best approach to eliminate the effects of condensation or crystallization is to install adequate insulation or heat tracing (steam or electrical). A flushing connection is no substitute for proper maintenance, but will help to reduce the frequency of the intervention.



CAGED-FOR DIRTY LIQUIDS

Unique to MAGNETROL, the Caged GWR probe is a single rod probe which uses an existing or new cage, bridle, or stillwell as the second conductor to re-create the same signal propagation of a coaxial GWR probe. Caged GWR probes are designed for 2" (DN50), 3" (DN80) or 4" (DN100) diameter metal chambers, and utilize a specially designed impedance matching section that results in the same overall characteristic impedance of a coaxial style GWR probe.

Caged GWR probes offer the same sensitivity and performance as coaxial GWR probes, but the single conductor design allows it to be used in applications with viscosities up to 10,000 cP (mPa.s).

MODEL 705/706 ADAPTOR

Designated by the 9th digit = A or B of the Model Number (see page 22), the Model 706 GWR transmitter with HART® digital output is available with an adapter that will enable operation with legacy Model 705 probes.

Installed in between the Model 706 transmitter and an existing, installed Model 705 probe, this unique accessory allows one to easily obtain all of the performance advantages, proactive diagnostics, and user-friendly configuration of the latest generation Model 706.



SINGLE ROD PROBES

Single element GWR probes operate quite differently from the coaxial design. With only one conductor to work with, the pulses of energy develop between the single rod probe and the mounting nut or flange. In other words, the pulse propagates down and around the rod as it references its ground at the top of the tank.

The energy and efficiency of the pulse are directly related to how much metallic surface exists around it at the top of the vessel. This metallic surface at the top of the probe is called the “launch plate.” The larger the launch plate, the more efficient the signal propagation down the probe.

Figure 2 shows the single element design and how the electromagnetic pulse effectively expands into a teardrop shape as it propagates away from the top of the tank (the inherent ground reference). This single element configuration (rod or cable) is the less efficient of the three probe types, but can still operate with a minimum dielectric detection of approximately $\epsilon_r > 1.7$ in an open, non-metallic vessel.

However, this dielectric constant performance improves considerably ($\epsilon_r > 1.4$) when the single rod probe is installed in a metal cage/bridle, or mounted 50–150 mm (2–6") away from a metal tank wall. Because the design is “open,” it exhibits two strong tendencies:

- It is the most forgiving of coating and buildup. (The PFA-insulated probe is the best choice for severe buildup and coating).
- It is most affected by proximity issues.

It is important to note that a parallel metal wall INCREASES the performance of a single rod probe while a singular, metal object protruding out near the probe may be improperly detected as a liquid level.

These tendencies are application/installation dependent. Therefore, by properly matching the single rod probe to a cage/chamber, the ECLIPSE Model 706 broad offering of caged probes combines the performance/sensitivity advantages of a coaxial probe and the viscosity immunity of a single rod probe. The Caged Probes are Overfill Safe by design, can be used in interface and other difficult, low dielectric applications, and are unique to MAGNETROL and the ECLIPSE Model 706.

Contact the factory for additional support and questions.

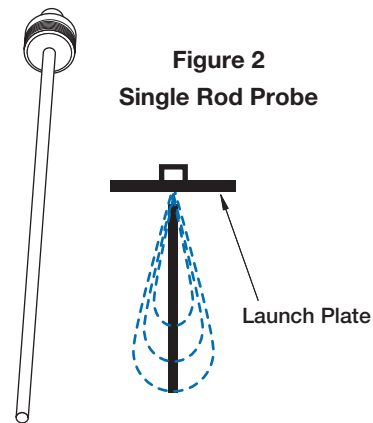

PROBE SELECTION GUIDE

COAXIAL/CAGED GWR PROBE

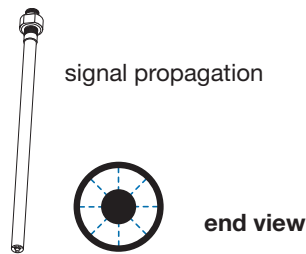

SINGLE ROD/CABLE PROBE

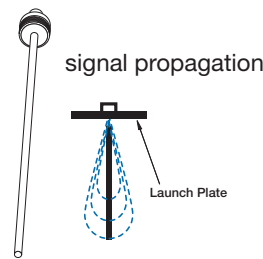

GWR Probe ^①	Description	Application	Installation	Dielectric Range ^{②③}	Temperature Range ^④	Max. Pressure	Vacuum ^⑤	Overfill Safe	Viscosity cP (mPa.s)
Coaxial GWR Probes—Liquids									
7yT	Standard Temperature	Level/Interface	Tank/Chamber	ϵ_r 1.4–100	-40 to +200 °C (-40 to +400 °F)	70 bar (1000 psi)	Yes	Yes	500/2000
7yP	High Pressure	Level/Interface	Tank/Chamber	ϵ_r 1.4–100	-196 to +200 °C (-320 to +400 °F)	431 bar (6250 psi)	Full	Yes	500/2000
7yD	High Temp./ High Press.	Level/Interface	Tank/Chamber	ϵ_r 1.4–100	-196 to +450 °C (-320 to +850 °F)	431 bar (6250 psi)	Full	Yes	500/2000
7yS	Steam Probe	Saturated Steam	Tank/Chamber	ϵ_r 10–100	-40 to +425 °C ^⑥ (-40 to +800 °F)	207 bar (3000 psi)	Full	No ^⑦	500
Caged GWR Probes—Liquids									
7yG	Standard Temperature	Level/Interface	Chamber	ϵ_r 1.4–100	-40 to +200 °C (-40 to +400 °F)	70 bar (1000 psi)	Yes	Yes	10000
7yL	High Pressure	Level/Interface	Chamber	ϵ_r 1.4–100	-196 to +200 °C (-320 to +400 °F)	431 bar (6250 psi)	Full	Yes	10000
7yJ	High Temp./ High Press.	Level/Interface	Chamber	ϵ_r 1.4–100	-196 to +450 °C (-320 to +850 °F)	431 bar (6250 psi)	Full	Yes	10000
Single Rod Rigid GWR Probes—Liquids									
7yF	Standard Temperature	Level/Interface	Tank	ϵ_r 1.7–100	-40 to +200 °C (-40 to +400 °F)	70 bar (1000 psi)	Yes	No ^⑧	10000
7yM	High Pressure	Level/Interface	Tank	ϵ_r 1.7–100	-196 to +200 °C (-320 to +400 °F)	431 bar (6250 psi)	Full	No ^⑧	10000
7yN	High Temp./ High Press.	Level/Interface	Tank	ϵ_r 1.7–100	-196 to +450 °C (-320 to +850 °F)	431 bar (6250 psi)	Full	No ^⑧	10000
Single Cable Flexible GWR Probes—Liquids									
7y1	Standard Temperature	Level/Interface	Tank	ϵ_r 1.7–100	-40 to +200 °C (-40 to +400 °F)	70 bar (1000 psi)	Yes	No ^⑧	10000
7y3	High Pressure	Level/Interface	Tank	ϵ_r 1.7–100	-196 to +200 °C (-320 to +400 °F)	431 bar (6250 psi)	Full	No ^⑧	10000
7y6	High Temp./ High Press.	Level/Interface	Chamber	ϵ_r 1.4–100	-196 to +450 °C (-320 to +850 °F)	431 bar (6250 psi)	Full	No ^⑧	10000
Single Cable Flexible GWR Probes—Solids									
7y2	Bulk Solids Probe	Level	Tank	ϵ_r 1.7–100	-40 to +65 °C (-40 to +150 °F)	Atmos.	No	No ^⑧	10000

① 2nd digit A=English, C=Metric.

② Minimum ϵ_r 1.2 with end of probe analysis enabled.

③ Single rod probes mounted directly into the vessel must be within 75–150 mm (3–6") of metal tank wall to obtain minimum dielectric of 1.4, otherwise ϵ_r min = 1.7.

④ Depends on the probe spacer material. Refer to Model Selection for spacer options.

⑤ ECLIPSE probes containing o-rings can be used for vacuum (negative pressure) service, but only those probes with glass seals are hermetically sealed to 10^{-9} cc/sec @ 1 atmosphere helium.

⑥ When installed in side-mounted chamber.

⑦ Consult factory for overfill applications.

⑧ Overfill capability can be achieved with software.

TRANSMITTER SPECIFICATIONS

FUNCTIONAL/PHYSICAL

System Design	
Measurement Principle	Guided Wave Radar based on Time Domain Reflectometry (TDR)
Input	
Measured Variable	Level, as determined by GWR time of flight
Span	15 cm to 30 m (6" to 100'); Model 7yS Probe 610 cm (20') max.
Output	
Type	4 to 20 mA with HART: 3.8 mA to 20.5 mA useable (per NAMUR NE43) FOUNDATION Fieldbus™: H1 (ITK Ver. 6.2.0) PROFIBUS PA Modbus
Resolution	Analog: .003 mA Digital Display: 1 mm
Loop Resistance	591 ohms @ 24 VDC and 22 mA
Diagnostic Alarm	Selectable: 3.6 mA, 22 mA (meets requirements of NAMUR NE 43), or HOLD last output
Diagnostic Indication	Meets requirements of NAMUR NE107
Damping	Adjustable 0–10 seconds
User Interface	
Keypad	4-button menu-driven data entry
Display	Graphic liquid crystal display
Digital Communication/Systems	HART Version 7—with Field Communicator, AMS, or FDT DTM (PACTware™), EDDL FOUNDATION Fieldbus™, PROFIBUS PA or Modbus
Menu Languages	Transmitter LCD: English, French, German, Spanish, Russian, Polish HART DD: English, French, German, Spanish, Russian, Chinese, Portuguese, Polish FOUNDATION Fieldbus™, PROFIBUS PA and Modbus Host System: English
Power (at transmitter terminals)	HART: General Purpose (Weather proof)/Intrinsically Safe/Explosion-proof: 16 to 36 VDC 11 VDC minimum under certain conditions (refer to I&O Manual BE57-606) FOUNDATION Fieldbus™ and PROFIBUS PA: 9 to 32 VDC FISCO ia / FNICO ic, Explosion Proof, General Purpose and Weatherproof Modbus: 8 to 30 VDC Explosion Proof, General Purpose, and Weatherproof
Housing	
Material	IP67/die-cast aluminum A413 (<0.6 % copper); optional 316 stainless steel
Net/Gross Weight	Aluminum: 2,0 kg (4.5 lbs.) 316 Stainless Steel: 4,50 kg (10.0 lbs.)
Overall Dimensions	H 212 mm (8.34") x W 102 mm (4.03") x D 192 mm (7.56")
Cable Entry	1/2" NPT or M20 x 1.5
SIL 2/3 Capable (Certified)	Safe Failure Fraction = 93 % (HART only) Functional Safety to SIL 2/3 in accordance with IEC 61508

TRANSMITTER SPECIFICATIONS CONTINUED

FUNCTIONAL/PHYSICAL

Environment	
Operating Temperature	-40 to +80 °C (-40 to +175 °F); LCD viewable -20 to +70 °C (-5 to +160 °F)
Storage Temperature	-45 to +85 °C (-50 to +185 °F)
Humidity	0 to 99 %, non-condensing
Electromagnetic Compatibility	Meets CE requirement (EN 61326) and NAMUR NE 21 ①
Surge Protection	Meets CE EN 61326 (1000V)
Shock/Vibration	ANSI/ISA-S71.03 Class SA1 (Shock); ANSI/ISA-S71.03 Class VC2 (Vibration)
Performance	
Reference Conditions ②	Reflection from liquid, with dielectric constant in center of selected range, with a 1,8 m (72") coaxial probe at +20 °C (+70 °F), in Auto Threshold Mode
Linearity ③	<0.1 % of probe length or 2,5 mm (0.1"), whichever is greater
Accuracy ④	±0.1 % of probe length or ±2,5 mm (0.1"), whichever is greater
Interface Operation:	±25 mm (1") for an interface thickness greater than 50 mm (2")
Resolution	±0.1 mm or 1"
Repeatability	<2,5 mm (0.1")
Hysteresis	<2,5 mm (0.1")
Response Time	Approximately 1 second
Initialization Time	Less than 10 seconds
Ambient Temperature Effect	Approx. ±0.02 % of probe length/°C (for probes greater than 2,5 m (8'))
Process Dielectric	<7,5 mm (0.3") within selected range
FOUNDATION Fieldbus™	
ITK Version	6.2.0
H1 Device Class	Link Master (LAS)—selectable ON/OFF
H1 Profile Class	31PS, 32L
Function Blocks	(8) AI, (3) Transducer, (1) Resource, (1) Arithmetic, (1) Input Selector, (1) Signal Characterizer, (2) PID, (1) Integrator
Quiescent Current	15 mA
Execution Time	15 ms (40 ms PID Block)
Device Revision	02
DD Version	0x01
PROFIBUS PA	
Device Revision	0x101A
Digital Communication Protocol	Version 3.02 MBP (31.25 kbits/sec)
Function Blocks	(1) × Physical Block, (8) × AI Blocks, (3) × Transducer Block
Quiescent Current	15 mA
Execution Time	15 ms
Modbus	
Power Consumption	<0.5W
Signal Wiring	Two-wire half duplex RS-485 Modbus
Ground (common mode) Voltage	±7V
Bus Termination	Per EIA-485

① Single rod probes must be used in metallic vessel or stillwell to maintain CE noise immunity.

② Specifications will degrade in Fixed Threshold mode.

③ Linearity in top 46 cm (18") of Single Rod probes in tanks will be application dependent.

④ Accuracy may degrade when using manual or automatic compensation.

COAXIAL PROBE MATRIX

	7yT	7yP
Description	Standard Temperature	High Pressure
Application	Level/Interface	Level/Interface
Installation	Tank/Chamber	Tank/Chamber
Overfill Safe	Yes	Yes
Materials—Probe	316/316L (1.4401/1.4404) Hastelloy® C (2.4819) Monel® (2.4360)	316/316L (1.4401/1.4404) Hastelloy® C (2.4819) Monel® (2.4360)
Process Seal	Teflon® TFE with Viton® o-rings ^①	Hermetic Glass Ceramic, Inconel ^⑦
Spacers	Teflon® TFE	Teflon® TFE
Probe Outside Diameter		
Enlarged	316 SS: 45 mm (1.75") Hastelloy: 49 mm (1.90") Monel: 49 mm (1.90")	316 SS: 45 mm (1.75") Hastelloy: 49 mm (1.90") Monel: 49 mm (1.90")
Basic	22,5 mm (0.87")	22,5 mm (0.87")
Process Connection		
Threaded	Enlarged 2" NPT (3/4" NPT or 1" BSP)	Enlarged 2" NPT (3/4" NPT or 1" BSP)
Flanged	Various ASME, EN1092, and proprietary flanges	Various ASME, EN1092, and proprietary flanges
Available Probe Length		
Standard	30 to 610 cm (12 to 240")	30 to 610 cm (12 to 240")
Enlarged	9 m (30') max segmented	9 m (30') max segmented
Transition Zones ^②		
Top	0 mm (0")	0 mm (0")
Bottom	$\epsilon_r = 1.4$: 150 mm (6") ^⑤ , $\epsilon_r = 80$: 50 mm (2")	$\epsilon_r = 1.4$: 150 mm (6") ^⑤ , $\epsilon_r = 80$: 50 mm (2")
Process Temperature	-40 to +200 °C (-40° to +400 °F)	-196 to +200 °C (-320° to +400 °F)
Max. Process Pressure ^③	70 bar @ +20 °C (1000 psi @ +70 °F)	431 bar @ +20 °C (6250 psi @ +70 °F)
Dielectric Range	1.4 to 100 ^⑥	1.4 to 100 ^⑥
Vacuum Service ^④	Negative Pressure, but no hermetic seal	Full Vacuum
Viscosity		
Enlarged	2000cP (mPa.s)	2000cP (mPa.s)
Basic	500cP (mPa.s)	500cP (mPa.s)
Media Coating	Filming	Filming

^① Other o-ring materials available upon request.

^② Transition zones (areas with reduced accuracy) are dielectric dependent. It is recommended to set the 0-100 % measuring range outside of the transition zones.

^③ Refer to chart on page 16.

^④ ECLIPSE probes containing o-rings can be used for vacuum (negative pressure) service, but only those probes with glass seal are hermetically sealed to <10⁻⁸ cc/sec @ 1 atmosphere helium.

^⑤ Can be reduced to 75 mm (3") when lower accuracy is acceptable.

^⑥ 1.2 minimum dielectric when end of probe analysis is enabled.

^⑦ Probes of Hastelloy C contain an Inconel 625 to Hastelloy C seal weld.

COAXIAL PROBE MATRIX CONTINUED

	7yD	7yS
Description	High Temp./High Pressure	Steam Probe
Application	Level/Interface	Saturated Steam
Installation	Tank/Chamber	Tank/Chamber
Overfill Safe	Yes	No ⑥
Materials—Probe	316/316L (1.4401/1.4404) Hastelloy® C (2.4819) Monel® (2.4360)	316/316L (1.4401/1.4404) Hastelloy® C (2.4819)
Process Seal	Hermetic Glass Ceramic, Inconel ⑨	Hermetic Glass Ceramic, PEEK HT, Inconel ⑨
Spacers	PEEK HT/Ceramic	PEEK HT/Ceramic
Probe Outside Diameter		
Enlarged	316 SS: 45 mm (1.75") Hastelloy: 49 mm (1.92") Monel: 49 mm (1.92")	N/A
Basic	22,5 mm (0.87")	22,5 mm (0.87")
High-Temp Model 7YS	N/A	31,8 mm (1.25")
Process Connection		
Threaded	2" NPT or 2" BSP	3/4" NPT or 1" BSP ⑦
Flanged	Various ASME, EN1092, and proprietary flanges	Various ASME, EN1092, and proprietary flanges
Available Probe Length		
Standard	30 to 610 cm (12 to 240")	60 to 610 cm (24 to 240")
Medium	N/A	60 to 244 cm (24 to 96")
Enlarged	9 m (30') max segmented	60 to 305 cm (24 to 120")
Transition Zones ①		
Top	0 mm (0")	200 mm (8")
Bottom	$\epsilon_r = 1.4$: 150 mm (6") ④, $\epsilon_r = 80$: 50 mm (2")	$\epsilon_r = 80$: 50 mm (2")
Process Temperature	-196 to 450 °C (-320 to +850 °F)	-50 to +425 °C (-58 to +800 °F) ⑧
Max. Process Pressure ②	431 bar @ +20°C (6250 psi @ +70 °F)	207 bar @ +20 °C (3000 psi @ +70 °F) 155 bar @ +345 °C (2250 psi @ +650 °F)
Dielectric Range	1.4 to 100 ⑤	10 to 100
Vacuum Service ③	Full Vacuum	Full Vacuum
Viscosity		
Enlarged	2000cP (mPa.s)	N/A
Basic	500cP (mPa.s)	500cP (mPa.s)
Media Coating	Filming	Filming

① Transition zones (areas with reduced accuracy) are dielectric dependent. It is recommended to set the 0-100 % measuring range outside of the transition zones.

② Refer to chart on page 16.

③ ECLIPSE probes containing o-rings can be used for vacuum (negative pressure) service, but only those probes with glass seal are hermetically sealed to $<10^{-9}$ cc/sec @ 1 atmosphere helium.

④ Can be reduced to 75 mm (3") when lower accuracy is acceptable.

⑤ 1.2 minimum dielectric when end of probe analysis is enabled.

⑥ Consult factory for overfill applications.

⑦ Not available with higher-temperature versions of the 7yS probe.

⑧ When installed in side-mounted chamber.

⑨ Probes of Hastelloy C contain an Inconel 625 to Hastelloy C seal weld.

CAGED PROBE MATRIX

	7yG	7yL	7yJ
Description	Standard Temperature	High Pressure	High Temp./High Pressure
Application	Level/Interface	Level/Interface	Level/Interface
Installation	Chamber	Chamber	Chamber
Overfill Safe ⑦	Yes	Yes	Yes
Materials—Probe	316/316L (1.4401/1.4404) Hastelloy® C (2.4819) Monel® (2.4360)	316/316L (1.4401/1.4404) Hastelloy® C (2.4819) Monel® (2.4360)	316/316L (1.4401/1.4404) Hastelloy® C (2.4819) Monel® (2.4360)
Process Seal	Teflon® TFE with Viton® o-rings①	Hermetic Glass Ceramic, Inconel®	Hermetic Glass Ceramic, Inconel®
Spacers	PEEK	PEEK	PEEK HT/Celazole
Probe Outside Diameter			
2" Chamber	13 mm (.5") to 19 mm (.75")	13 mm (.5") to 19 mm (.75")	13 mm (.5") to 19 mm (.75")
3" Chamber	19 mm (.75") to 29 mm (1.13")	19 mm (.75") to 29 mm (1.13")	19 mm (.75") to 29 mm (1.13")
4" Chamber	27 mm (1.05") to 38 mm (1.50")	27 mm (1.05") to 38 mm (1.50")	27 mm (1.05") to 38 mm (1.50")
Process Connection			
Flanged	Various ASME, EN1092, and proprietary flanges	Various ASME, EN1092, and proprietary flanges	Various ASME, EN1092, and proprietary flanges
Available Probe Length	30 to 610 cm (12 to 240")	30 to 610 cm (12 to 240")	30 to 610 cm (12 to 240")
Transition Zones ②			
Top	0 mm (0")	0 mm (0")	0 mm (0")
Bottom	$\epsilon_r = 1.4$: 150 mm (6") ⑤, $\epsilon_r = 80$: 50 mm (2")	$\epsilon_r = 1.4$: 150 mm (6") ⑤, $\epsilon_r = 80$: 50 mm (2")	$\epsilon_r = 1.4$: 150 mm (6") ⑤, $\epsilon_r = 80$: 50 mm (2")
Process Temperature	-40 to +200 °C (-40 to +400 °F)	-196 to +200 °C (-320 to +400 °F)	-196 to +450 °C (-320 to +850 °F)
Max. Process Pressure ③	70 bar @ +20 °C (1000 psi @ +70 °F)	431 bar @ +20 °C (6250 psi @ +70 °F)	431 bar @ +20 °C (6250 psi @ +70 °F)
Dielectric Range ⑦	1.4 to 100 ⑥	1.4 to 100 ⑥	1.4 to 100 ⑥
Vacuum Service ④	Negative Pressure, but no hermetic seal	Full Vacuum	Full Vacuum
Viscosity	10,000cP (mPa.s)	10,000cP (mPa.s)	10,000cP (mPa.s)
Media Coating	Maximum Error 10 % of coated length (% Error is dependent on dielectric and thickness)	Maximum Error 10 % of coated length (% Error is dependent on dielectric and thickness)	Maximum Error 10 % of coated length (% Error is dependent on dielectric and thickness)

① Other o-ring materials available upon request.

② Transition zones (areas with reduced accuracy) are dielectric dependent. It is recommended to set the 0-100 % measuring range outside of the transition zones.

③ Refer to chart on page 16.

④ ECLIPSE probes containing o-rings can be used for vacuum (negative pressure) service, but only those probes with glass seal are hermetically sealed to 10^{-9} cc/sec @ 1 atmosphere helium.

⑤ Can be reduced to 75 mm (3") when lower accuracy is acceptable.

⑥ 1.2 minimum dielectric when end of probe analysis is enabled.

⑦ When installed in the proper chamber/cage/stilling well.

⑧ Probes of Hastelloy C contain an Inconel 625 to Hastelloy C seal weld.

SINGLE ROD RIGID PROBE MATRIX

	7yF	7yM	7yN
Description	Standard Temperature	High Pressure	High Temp./High Pressure
Application	Level/Interface	Level/Interface	Level/Interface
Installation	Tank	Tank	Tank
Overfill Safe ⑦	No	No	No
Materials—Probe	316/316L (1.4401/1.4404) Hastelloy® C (2.4819) Monel® (2.4360) PFA Insulated 316/316L rod	316/316L (1.4401/1.4404) Hastelloy® C (2.4819) Monel® (2.4360)	316/316L (1.4401/1.4404) Hastelloy® C (2.4819) Monel® (2.4360)
Process Seal	Teflon® TFE with Viton® o-rings①	Hermetic Glass Ceramic, Inconel®	Hermetic Glass Ceramic, Inconel®
Spacers	None	None	PEEK HT/Celazole
Probe Outside Diameter	Bare: 10 mm (0.38") rod Coated: 16 mm (0.625") rod	Bare: 10 mm (0.38") rod	Bare: 13 mm (0.50") rod
Process Connection			
Threaded Flanged	1" or 2" (NPT or BSP) Various ASME, EN1092, and proprietary flanges	1" or 2" (NPT or BSP) Various ASME, EN1092, and proprietary flanges	2" (NPT or BSP) Various ASME, EN1092, and proprietary flanges
Available Probe Length	60 to 732 cm (24" to 288") 610 cm (240") maximum for PFA coated probes	60 to 732 cm (24" to 288")	60 to 732 cm (24" to 288")
Transition Zones ②			
Top Bottom	Application Dependent $\epsilon_r = 1.4$: 150 mm (6") ⑤, $\epsilon_r = 80$: 50 mm (2")	Application Dependent $\epsilon_r = 1.4$: 150 mm (6") ⑤, $\epsilon_r = 80$: 50 mm (2")	Application Dependent $\epsilon_r = 1.4$: 150 mm (6") ⑤, $\epsilon_r = 80$: 50 mm (2")
Process Temperature	-40 to +200 °C (-40 to +400 °F)	-196 to +200 °C (-320 to +400 °F)	-196 to +450 °C (-320 to +850 °F)
Max. Process Pressure ③	70 bar @ +20 °C (1000 psi @ +70 °F)	431 bar @ +20 °C (6250 psi @ +70 °F)	431 bar @ +20 °C (6250 psi @ +70 °F)
Dielectric Range	1.7 to 100 ⑥	1.7 to 100 ⑥	1.7 to 100 ⑥
Vacuum Service ④	Negative Pressure, but no hermetic seal	Full Vacuum	Full Vacuum
Viscosity	10,000cP (mPa.s)	10,000cP (mPa.s)	10,000cP (mPa.s)
Media Coating	Maximum Error 10 % of coated length (% Error is dependent on dielectric and thickness)	Maximum Error 10 % of coated length (% Error is dependent on dielectric and thickness)	Maximum Error 10 % of coated length (% Error is dependent on dielectric and thickness)

① Other o-ring materials available upon request.

② Transition zones (areas with reduced accuracy) are dielectric dependent. It is recommended to set the 0-100 % measuring range outside of the transition zones.

③ Refer to chart on page 16.

④ ECLIPSE probes containing o-rings can be used for vacuum (negative pressure) service, but only those probes with glass seal are hermetically sealed to $<10^{-8}$ cc/sec @ 1 atmosphere helium.

⑤ Can be reduced to 75 mm (3") when lower accuracy is acceptable.

⑥ 1.2 minimum dielectric when end of probe analysis is enabled.

⑦ Overfill capability can be achieved with software.

⑧ Probes of Hastelloy C contain an Inconel 625 to Hastelloy C seal weld.

FLEXIBLE PROBES FOR LIQUIDS MATRIX

	7y1	7y3	7y6
Description	Single Flexible Standard Temperature	Single Flexible High Pressure	Single Flexible HTHP
Application	Level/Interface	Level/Interface	Level/Interface
Installation	Tank	Tank	Chamber
Overfill Safe ⑦	No	No	No
Materials—Cable	316 (1.4401) (optional PFA coating)	316 (1.4401)	316 (1.4401)
Process Seal	Teflon® TFE with Viton® o-rings①	Hermetic Glass Ceramic, Inconel ⑥	Hermetic Glass Ceramic, Inconel ⑥
Probe Outside Diameter	5 mm (0.19")	5 mm (0.19")	5 mm (0.19")
Process Connection			
Threaded	2" NPT or 2" BSP	2" NPT or 2" BSP	2" NPT or 2" BSP
Flanged	Various ASME, EN1092, and proprietary flanges	Various ASME, EN1092, and proprietary flanges	Various ASME, EN, and proprietary flanges
Available Probe Length	1 to 30 m (3 to 100')	1 to 30 m (3 to 100')	1 to 30 m (3 to 100')
Transition Zones ②			
Top	45 cm (18")	45 cm (18")	45 cm (18")
Bottom	30 cm (12")	30 cm (12")	30 cm (12")
Process Temperature	-40 to +200 °C (-40 to +400 °F)	-196 to +200 °C (-320 to +400 °F)	-196 to +450 °C (-320 to +850 °F)
Max. Process Pressure ③	70 bar @ +20°C (1000 psi @ +70 °F)	431 bar @ +20 °C (6250 psi @ +70 °F)	431 bar @ +20 °C (6250 psi @ +70 °F)
Dielectric Range ⑤	1.7 to 100	1.7 to 100	1.7 to 100
Vacuum Service ④	Negative Pressure, but no hermetic seal	Full Vacuum	Full Vacuum
Viscosity	10,000 (mPa.s)	10,000 (mPa.s)	10,000 (mPa.s)
Media Coating	Maximum Error 10 % of coated length (% Error is dependent on dielectric and thickness)	Maximum Error 10 % of coated length (% Error is dependent on dielectric and thickness)	Maximum Error 10 % of coated length (% Error is dependent on dielectric and thickness)

① Other o-ring materials available upon request.

② Transition zones (areas with reduced accuracy) are dielectric dependent. It is recommended to set the 0-100 % measuring range outside of the transition zones.

③ Refer to chart on page 16.

④ ECLIPSE probes containing o-rings can be used for vacuum (negative pressure) service, but only those probes with glass seal are hermetically sealed to 10^{-8} cc/sec @ 1 atmosphere helium.

⑤ 1.2 minimum dielectric when end of probe analysis is enabled.

⑥ Probes of Hastelloy C contain an Inconel 625 to Hastelloy C seal weld.

⑦ Overfill capability can be achieved with software.

FLEXIBLE PROBES FOR SOLIDS MATRIX

	7y2
Description	Single Flexible Standard Temp.
Application	Level
Installation	Tank
Overfill Safe	No
Pull Down Force	1360 Kg (3000 lbs.)
Materials—Cable	316 (1.4401)
Probe Outside Diameter	5 mm (0.19")
Process Connection	2" NPT or 2" BSP Various ASME, EN1092, and proprietary flanges
Threaded Flanged	
Available Probe Length	1 to 30 m (3 to 100')
Transition Zones ①	45 cm (18") 30 cm (12")
Top Bottom	
Dielectric Range ②	1.7 to 100
Vacuum Service ③	Negative Pressure, but no hermetic seal
Viscosity	10,000 (mPa.s)
Media Coating	Max. Error 10 % of coated length (% Error is dependent on dielectric & thickness)

① Transition zones (areas with reduced accuracy) are dielectric dependent. It is recommended to set the 0-100 % measuring range outside of the transition zones.

② 1.2 minimum dielectric when end of probe analysis is enabled.

③ ECLIPSE probes containing o-rings can be used for vacuum (negative pressure) service, but only those probes with glass seal are hermetically sealed (helium leak <10⁻⁶cc/sec @ 1 atmos.).

TEMPERATURE / PRESSURE

**7yL, 7yM and 7yP (high pressure probes)
Temperature/Pressure Ratings**

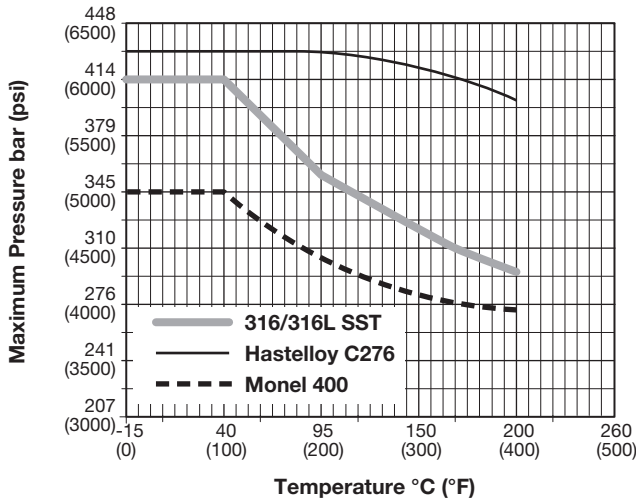

**7yD, 7yJ, 7yN, 7y3 and 7y6 (high temp./high pressure probes)
Temperature/Pressure Ratings**

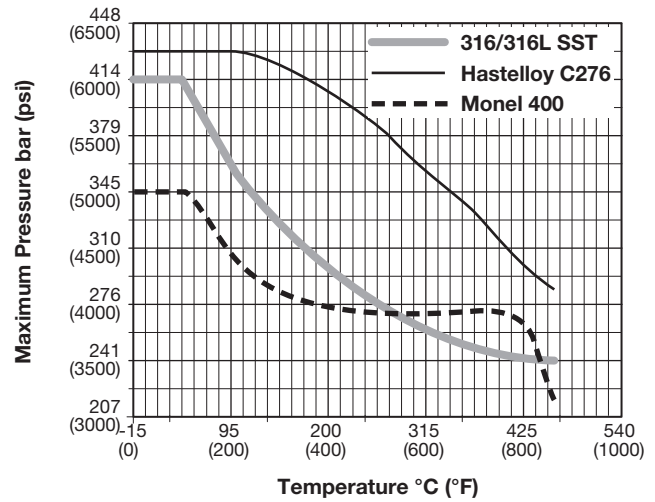

**7yF, 7yG, 7yT, 7y1
Temperature/Pressure Ratings**

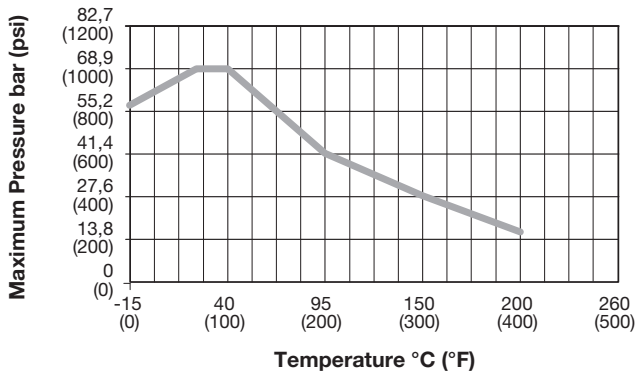

High Pressure Probes				Low Pressure	High Pressure Probes				Low Pressure
Temp. °C (°F)	SST	Hastelloy	Monel	All Materials	Temp. °C (°F)	SST	Hastelloy	Monel	All Materials
-40 (-40)	6000	6250	5000	750	315 (+600)	3760	5040	3940	—
20 (+70)	6000	6250	5000	1000	345 (+650)	3680	4905	3940	—
40 (+100)	6000	6250	5000	1000	370 (+700)	3620	4730	3920	—
95 (+200)	5160	6250	4380	650	400 (+750)	3560	4430	3880	—
150 (+300)	4660	6070	4080	400	425 (+800)	3520	4230	3820	—
200 (+400)	4280	5820	3940	270	450 (+850)	3480	4060	3145	—
260 (+500)	3980	5540	3940	—					

- 7yS steam probes are rated to 3000 psi (207 bar) up to +425 °C (+800 °F) when installed in side-mounted chamber.
- 7y3, 7y6 flexible probes: Pressure is limited by the chamber.
- 7y2 bulk solids probes: 50 psi (3.45 bar) to +65 °C (+150 °F).
- High pressure probes with threaded fittings are rated as follows: 7yD, 7yN, 7yP and 7y3 probes with threaded fittings have 3600 psi (248 bar) rating. 7yM probes with threaded fittings have 2016 psi (139 bar) rating.
- Maximum pressure for 1" NPT or 1" BSP:
316 SST probe: 139 bar (2016 psi) • Hast. C276 probe: 145 bar (2100 psi) • Monel probe: 116 bar (1680 psi)
- Maximum pressure for 2" NPT or 2" BSP:
316 SST probe: 414 bar (6000 psi) • Hast. C276 probe: 431 bar (6250 psi) • Monel probe: 345 bar (5000 psi)

O-RING (SEAL) SELECTION CHART

O-RING/SEAL SPECIFICATIONS

Code	"O"-Ring/Seal Material	Max. Process Temperature	Min. Process Temperature	Max. Process Pressure	Not Recommended For Applications	Recommended for Applications
0	Viton® GFLT	200 °C @ 16 bar (400 °F @ 230 psi)	-40 °C (-40 °F)	70 bar @ 20 °C (1000 psi @ 70 °F)	Ketones (MEK, acetone), skydrol fluids, amines, anhydrous ammonia, low molecular weight esters and ethers, hot hydrofluoric or chlorosulfuric acids, sour HCs	General purpose, ethylene
1	EPDM	120 °C @ 14 bar (250 °F @ 200 psi)	-50 °C (-60 °F)	70 bar @ 20 °C (1000 psi @ 70 °F)	Petroleum oils, di-ester base lubricant, steam	Acetone, MEK, skydrol fluids
2	Kalrez® 4079	200 °C @ 16 bar (400 °F @ 232 psi)	-40 °C (-40 °F)	70 bar @ 20 °C (1000 psi @ 70 °F)	Hot water/steam, hot aliphatic amines, ethylene oxide, propylene oxide	Inorganic and organic acids (including hydro fluids and nitric), aldehydes, ethylene, organic oils, glycols, silicone oils, vinegar, sour HCs
3	HSN (Highly Saturated Nitrile)	135 °C @ 22 bar (275 °F @ 320 psi)	-20 °C (-4 °F)	70 bar @ 20 °C (1000 psi @ 70 °F)	Halogenated HCs, nitro HCs, phosphate ester hydraulic fluids, ketones (MEK, acetone), strong acids, ozone, automotive brake fluid, steam	NACE applications
4	Buna-N	135 °C @ 22 bar (275 °F @ 320 psi)	-20 °C (-4 °F)	70 bar @ 20 °C (1000 psi @ 70 °F)	Halogenated HCs, nitro HCs, phosphate ester hydraulic fluids, ketones (MEK, acetone), strong acids, ozone, automotive brake fluid	General purpose sealing, petroleum oils and fluids, cold water, silicone greases and oils, di-ester base lubricants, ethylene glycol base fluids
5	Neoprene®	120 °C @ 20 bar (250 °F @ 290 psi)	-55 °C (-65 °F)	70 bar @ 20 °C (1000 psi @ 70 °F)	Phosphate ester fluids, ketones (MEK, acetone)	Refrigerants, high aniline point petroleum oils, silicate ester lubricants
6	Chemraz® 505	200 °C @ 14 bar (400 °F @ 200 psi)	-20 °F (-30 °C)	70 bar @ 20 °C (1000 psi @ 70 °F)	Acetaldehyde, ammonia + lithium metal solution, butyraldehyde, di-water, freon, ethylene oxide, liquors, isobutyraldehyde	Inorganic and organic acids, alkalines, ketones, esters, aldehydes, fuels
7	Polyurethane	95 °C @ 29 bar (200 °F @ 420 psi)	-55 °C (-65 °F)	70 bar @ 20 °C (1000 psi @ 70 °F)	Acids, Ketones, chlorinated HCs	Hydraulic systems, petroleum oils, HC fuel, oxygen, ozone
8	Simriz SZ485 (formerly Aegis PF128) ①	200 °C @ 16 bar (400 °F @ 232 psi)	-20 °C (-4 °F)	70 bar @ 20 °C (1000 psi @ 70 °F)	Black liquor, freon 43, freon 75, galden, KEL-F liquid, molten potassium, molten sodium	Inorganic and organic acids (including hydro fluids and nitric), aldehydes, ethylene, organic oils, glycols, silicone oils, vinegar, sour HCs, steam, amines, ethylene oxide, propylene oxide, NACE applications
A	Kalrez® 6375	200 °C @ 16 bar (400 °F @ 232 psi)	-40 °C (-40 °F)	70 bar @ 20 °C (1000 psi @ 70 °F)	Hot water/steam, hot aliphatic amines	Inorganic and organic acids (including hydro fluids and nitric), aldehydes, ethylene, organic oils, glycols, silicone oils, vinegar, sour HCs, ethylene oxide, propylene oxide
B	Kalrez® 6375	200 °C @ 16 bar (400 °F @ 232 psi)	-40 °C (-40 °F)	70 bar @ 20 °C (1000 psi @ 70 °F)	Hot water/steam, hot aliphatic amines, ethylene oxide, propylene oxide	Hydrofluoric acid
D or N	Glass Ceramic Alloy	450 °C @ 248 bar (850 °F @ 3600 psi)	-195 °C (-320 °F)	431 bar @ 20 °C (6250 psi @ 70 °F)	Hot alkaline solutions HF acid, media with ph>12, direct exposure to saturated steam	General high temperature/high pressure applications, hydrocarbons, full vacuum (hermetic), ammonia, chlorine

① Maximum +150 °C (+300 °F) for use on steam.

REPLACEMENT OF DISPLACER TRANSMITTERS

ECLIPSE has proven to be the ideal replacement for existing torque tube transmitters. In numerous applications worldwide, customers have found the performance of ECLIPSE Guided Wave Radar transmitters to be superior to that of antiquated torque tube transmitters.

There are several benefits to using the ECLIPSE Model 706 as a replacement for torque tube transmitters:

• Cost:

The cost of a new Model 706 transmitter cost is comparable to rebuilding an aging torque tube.

• Installation:

No field calibration is necessary. The Model 706 transmitter can be configured in minutes with no level movement. (Complete factory pre-configuration is available, which can further decrease the installation effort).

• Performance:

The ECLIPSE Model 706 is unaffected by changes in specific gravity and has no moving parts that can wear and lose tolerance.

• Ease of replacement:

Proprietary and standard ASME flanges are offered on all ECLIPSE Model 706 probes so existing chamber/cages can be used.

In order to match the proper ECLIPSE transmitter with the proper external cage, consider the following:

• Type of application:

Use the proper GWR probe for the application, see pages 7 and 10 through 16.

• Overfill proof:

For optimum performance, use an Overfill-safe probe in all chamber applications.

Note: “Overfill” occurs when the level rises above the maximum range of operation. *Some GWR probes may provide erroneous output in this zone unless an optimal, impedance-matched design is used.*

• Minimum Cage Size:

- Coaxial or Caged Coaxial probes: 2" minimum
- Enlarged Coaxial probes: 3" minimum

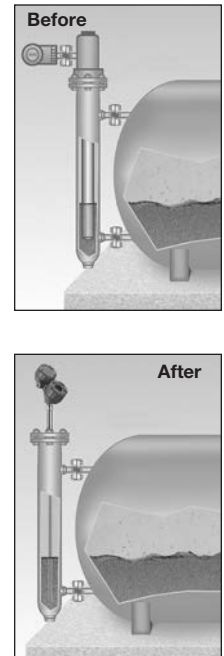
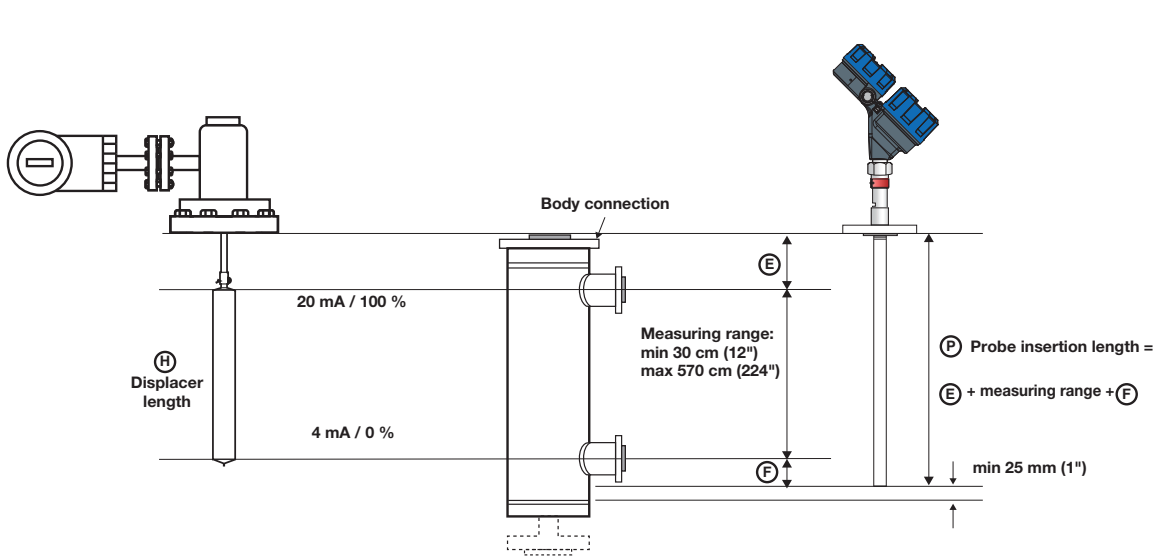

Recommended probe length for replacing displacer transmitters

The table below helps to define the GWR probe length for the most common displacer transmitters. Refer to the proprietary flange selection guide.

Manufacturer	Type	Process Connection	Displacer Length mm (inches)	Probe Length ① mm (inches)
MAGNETROL	EZ & PN Modulevel®	ASME/EN flange	≥ 356 (14)	Displacer + 178 (7)
Masoneilan®	Series 1200	Proprietary flange	≥ 356 (14)	Displacer + 203 (8)
		ASME/EN flange	≥ 406 (16)	Displacer + 203 (8)
Fisher® series 2300 & 2500	249B, 259B, 249C cages	Proprietary flange	≥ 356 (14)	Displacer + 254 (10)
	other cages	ASME flange	≥ 356 (14)	consult factory
Eckardt®	Series 134, 144	ASME/EN flange	≥ 356 (14)	consult factory
Tokyo Keiso®	FST-3000	ASME/EN flange	H = 300 (11.8)	Displacer + 229 (9)
		ASME/EN flange	≥ H = 500 (19.7)	Displacer + 229 (9)

① Round down resulting calculation to the nearest inch.

PROPRIETARY FLANGES

mm (inches)

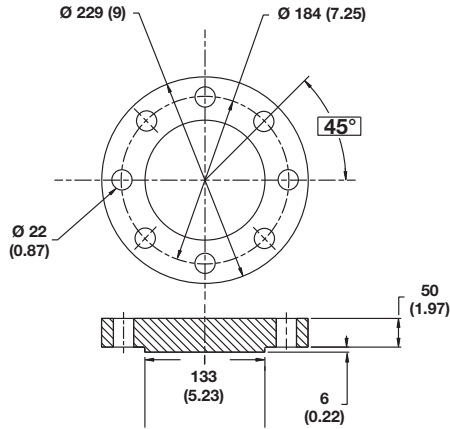

Fisher 249B/259B (600 lbs.), carbon steel

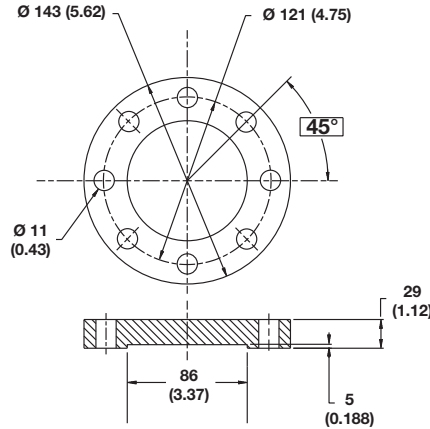

Fisher 249C (600 lbs.), 316 stainless steel

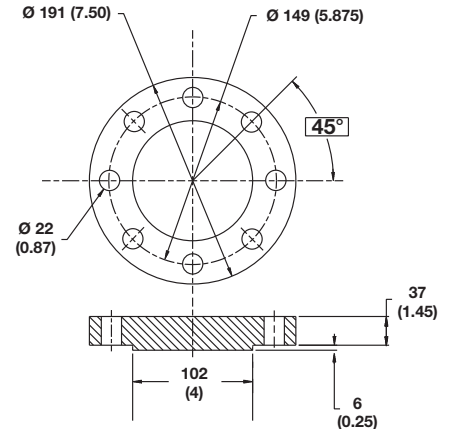

Masoneilan (600 lbs.), carbon steel

MAGNETROL CHAMBERS

A brief description of the MAGNETROL chamber offering follows. For more details, refer to MAGNETROL Sales Bulletin BE57-140.

MAGNETROL has a long tradition in offering cost-effective chambers. The MAGNETROL external chamber is a self-contained cage designed for use with our top mounting level transmitters or switches. Quality construction and a wide selection of configurations make this cage an ideal means of utilizing the power of Guided Wave Radar without mounting directly into the process vessel.



MAGNETROL chambers are available with a wide variety of options, and can be manufactured to comply with various regulations such as:

- Commercial Design
- ASME B31.1 Design Code
- ASME B31.3 Design Code
- NACE Design Code
- PED

Some Model 706 probes can be installed into chambers as small as 2". When a new chamber is required, it can be ordered together with a factory pre-configured Model 706 for a true "plug and play" installation.

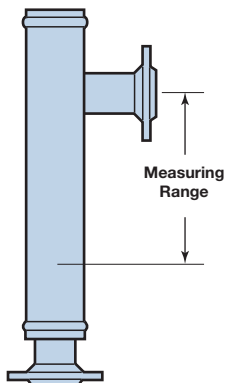

Sealed Chamber

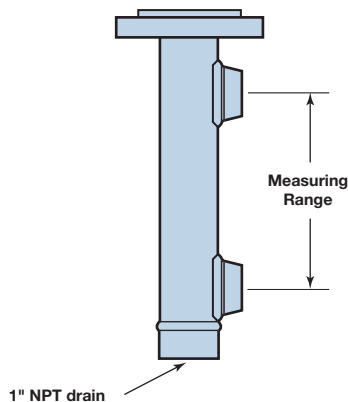

Slip-on head flange

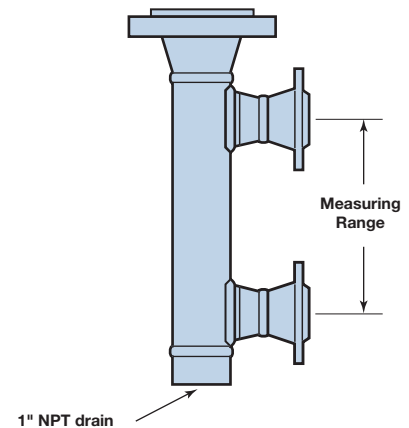

Weld neck head flange

AGENCY APPROVALS



These units are in compliance with the EMC-directive 2014/30/EU.
The PED-directive 2014/68/EU and the ATEX directive 2014/34/EU.

<p>Explosion Proof (with intrinsically Safe Probe)</p> <p>US/Canada: Class I, Div 1, Group B, C and D, T4 Class I, Zone 1 AEx db/ia [ia IIC Ga] IIB + H2 T4 Gb/Ga Class I, Zone 1 Ex db/ia [ia IIC Ga] IIB + H2 T4 Gb/Ga Ta = -40 °C to +70 °C Type 4X, IP67</p> <p>Flame Proof</p> <p>ATEX – FM14ATEX0041X: II 2/1 G Ex db/ia [ia IIC Ga] IIB + H2 T6 to T1 Gb/Ga Ta = -40 °C to +70 °C IP67</p> <p>IEC- IECEX FMG 14.0018X: Ex db/ia [ia IIC Ga] IIB + H2 T6 to T1 Gb/Ga Ta = -40 °C to +70 °C IP67</p>	<p>Non- Incendive</p> <p>US/Canada: US Class I, II, III, Division 2, Group A, B, C, D, E, F, G, T4 Canada: Class I, Division 2, Group A, B, C, D Class I, Zone 2 AEx nA [ia Ga] IIC T4 Gc Class I, Zone 2 Ex nA [ia Ga] IIC T4 Gc Ta = -40 °C to +70 °C Type 4X, IP67</p> <p>ATEX II 3 (1) G Ex nA [ia Ga] IIC T4 Gc II 3 G Ex ic IIC T4 Gc Ta = -15 °C to +70 °C IP67</p> <p>IEC – IECEX FMG 14.00018X: Ex nA [ia Ga] IIC T4 Ga/Gc Ta = -15 °C to +70 °C IP67</p>
<p>Intrinsically Safe</p> <p>US/Canada: Class I, II, III, Div 1, Group A, B, C, D, E, F, G, T4 Class I, Zone 0 AEx ia IIC T4 Ga Class I, Zone 0 Ex ia IIC T4 Ga Ta = -40 °C to +70 °C Type 4X, IP67</p> <p>ATEX – FM14ATEX0041X: II 1 G Ex ia IIC T4 Ga II 3 G ic IIC T4 Gc Ta = -40 °C to +70 °C IP67</p> <p>IEC – IECEX FMG 14.0018X: Ex ia IIC T4 Ga Ex ic IIC T4 Gc Ta = -40 °C to +70 °C IP67</p>	<p>Dust Ignition Proof</p> <p>US/Canada: Class II, III, Division 1, Group E, F and G, T4 Ta = -40 °C to +70 °C Type 4X, IP67</p> <p>ATEX – FM14ATEX0041X: II 1/2 D Ex ia/tb [ia Da] IIIC T85 °C to T450 °C Da/Db Ta = -15 °C to +70 °C IP67</p> <p>IEC – IECEX FMG 14.0018X: Ex ia tb [ia Da] IIIC T85 °C to T450 °C Db Ex ia IIIC T85 °C to T450 °C Da Ta = -15 °C to +70 °C IP67</p>

The following approval standards are applicable:

FM3600:2018, FM3610:2010, FM3611:2018, FM3615:2018, FM3616:2011, FM3810:2018, UL60079-0:2019, UL 60079-1:2015, ANSI/ISA 60079-11:2014, ANSI/ISA 60079-15:2012, ANSI/ISA 60079-26:2014, ANSI/NEMA 250:2003, ANSI/IEC 60529:2004, ANSI/UL 61010:2015, CSA-C22.2 No. 0.4:2009, CSA-C22.2 No. 0.5:2008, CSA-C22.2 No. 25:2009, CSA-C22.2 No. 30:2007, CSA-C22.2 No. 94:2001, CSA-C22.2 No. 157:2012, CSA-C22.2 No. 213:2012, CSA-C22.2 No. 1010.1:2009 CAN/CSA 60079-0:2019, CAN/CSA 60079-1:2016 CAN/CSA 60079-11:2011 CAN/CSA 60079-15:2012 C22.2 No. 60529:R2010, ANSI/ISA 12.27.01, EN/IEC60079-0:2018, EN60079-1:2014, EN60079-11:2012, EN60079-15:2010, EN60079-26:2015, EN60079-31:2014, EN60529+A1:1991-2000, IEC60079-0:2017, IEC60079-1:2014, IEC60079-11:2011, IEC60079-15:2010, IEC60079-26:2006, IEC60079-31:2008, ANSI/ISA 12.27.01:2011, ANSI/UL 61010:2015

Lloyd's Register LR Type Approval - Marine, offshore and industrial applications for use in environmental categories ENV 1, 2, and 5 as defined in the Type Approval Test Specification No. 1 (2015).

Lloyd's Register Steamdrum Approval – EN 12953-9 and EN 12952-11

AGENCY APPROVALS

Special Conditions of Use

1. The enclosure contains aluminum and is considered to present a potential risk of ignition by impact or friction. Care must be taken during installation and use to prevent impact or friction.
2. The risk of electrostatic discharge shall be minimized at installation, following the directions given in the instructions.
3. Contact the original manufacturer for information on the dimensions of the flameproof joints.
4. For installation with ambient temperature of +70 °C, refer to the manufacturer's instructions for guidance on proper selection of conductors.
5. **WARNING** — Explosion Hazard: Do not disconnect equipment when flammable or combustible atmosphere is present.
6. For IEC and ATEX: To maintain the T1 to T6 temperature codes, care shall be taken to ensure the enclosure temperature does not exceed +75 °C.
7. For U.S. and Canada: To maintain the T4 temperature code, care shall be taken to ensure the enclosure temperature does not exceed +70 °C.
8. Temperature codes for the ratings Ex db/ia [ia IIC] IIB+H2 and Ex ia/tb [ia] IIIC are defined by the following table:

Process Temperature (PT)	Temperature Code-TCG (GAS)	Temperature Code-TCD (Dust)
Up to 75 °C	T6	TCD= PT+10K=85 °C
From 75 °C to 90 °C	T5	TCD= PT+10K=100 °C
From 90 °C to 120 °C	T4	TCD= PT+15K=135 °C
From 125 °C to 185 °C	T3	TCD= PT+15K=200 °C
From 185 °C to 285 °C	T2	TCD= PT+15K=300 °C
From 285 °C to 435 °C	T1	TCD= PT+15K=450 °C

9. Flameproof joints are not intended to be repaired.
10. To maintain FM approval, the Model 706 transmitter with adapter shall only be used on Model 705 assemblies approved by FM Global. (Includes FM, CSA, ATEX and IEC).
11. Provisions shall be made to provide transient over-voltage protection to a level not to exceed 119 V DC.

Agency Specifications – Explosion Proof Installation

Factory Sealed: This product has been approved by **Factory Mutual Research (FM)** and **Canadian Standards Association (CSA)** as a **Factory Sealed device**.

NOTE: Factory Sealed: No Explosion Proof conduit fitting (EY seal) is required within 18" of the transmitter. However, an Explosion Proof conduit fitting (EY seal) is required between the hazardous and safe areas.

QUICK RESPONSE CELL (QRC)

Several models are available for extra quick shipment, within max. 15 days after factory receipt of purchase order, through the Quick Response Cell (QRC). To take advantage of QRC, simply match the green model number codes.

QRC delivery is limited to a maximum of 10 units per order. Contact your local representative for lead times on larger volume orders, as well as other products and options.

EXPEDITE SHIP PLAN (ESP)

Several models are available for quick shipment, within max. 4 weeks after factory receipt of purchase order, through the Expedite Ship Plan (ESP). To take advantage of ESP, simply match the blue (or combination of green and blue) model number codes.

ESP delivery is limited to a maximum of 10 units per order. Contact your local representative for lead times on larger volume orders, as well as other products and options.

MODEL NUMBER

TRANSMITTER

1 2 3 | BASIC MODEL NUMBER

7 0 6	ECLIPSE 4th Generation Guided Wave Radar (GWR) Level Transmitter
-------	--

4 | POWER

5	24 VDC, Two-Wire
---	------------------

5 | SIGNAL OUTPUT

1	4–20 mA with HART
2	FOUNDATION Fieldbus™ Communication
3	PROFIBUS PA Communication
4	Modbus Communication (8th Digit = 0 or 3 only)

6 | SAFETY OPTIONS

0	None – FOUNDATION Fieldbus™, PROFIBUS PA and Modbus only (5th digit = 2, 3 or 4)
2	SIL 2/3 Certified - HART only (5th digit = 1)

7 | ACCESSORIES/MOUNTING

0	No Digital Display or Keypad - Integral
A	Digital Display and Keypad - Integral
B	Digital Display and Keypad - 1 m (3') remote
C	Digital Display and Keypad - 3,6 m (12') remote

8 | CLASSIFICATION

0	General Purpose, Weatherproof (IP 67)
1	Intrinsically Safe (FM & CSA CL 1 Div 1, Grps A, B, C, D) (5th digit = 1, 2 or 3)
3	Explosion-proof (FM & CSA CL 1 Div 1, Grps B, C, D)
A	Intrinsically Safe (ATEX/IEC Ex ia IIC T4) (5th digit = 1, 2 or 3)
B	Flame-proof (ATEX/IEC Ex d ia IIB + H2 T6) (5th digit = 1, 2 or 3)
C	Non-sparking (ATEX Ex n IIC T6) / Non-incendive (FM & CSA, CL 1 Div 2) (5th digit = 1, 2 or 3) ①
D	Dust Ex (ATEX II) (5th digit = 1, 2 or 3)

① Consult factory for proper part numbers.

9 | HOUSING

1	Die-cast Aluminum, Dual-compartment, 45-degree
2	Investment Cast, 316 SS, Dual-compartment, 45-degree
A	Die-cast Aluminium, Dual-compartment, 45-degree with 705/706 adapter ②
B	Investment Cast, 316 SS, Dual-compartment, 45-degree with 705/706 adapter ②

② Not available with 5th digit = 3.

10 | CONDUIT CONNECTION

0	1/2" NPT
1	M20 x 1.5
2	1/2" NPT with sunshade
3	M20 x 1.5 with sunshade



DIMENSIONS

mm (inches)

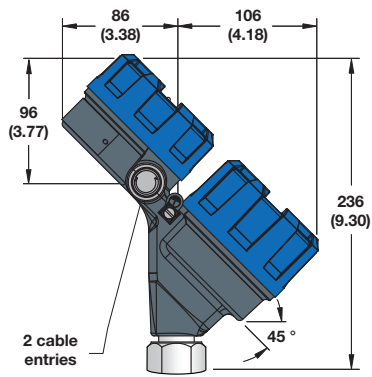

Integral Electronics

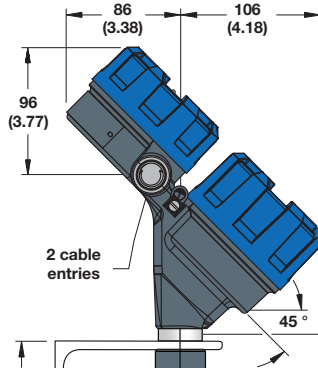

Eclipse® Remote Configurations

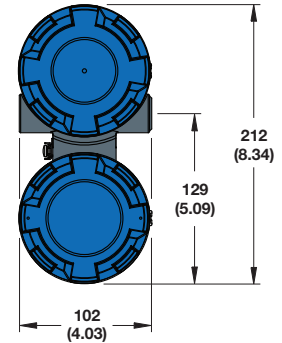

Eclipse® Housing (45° View)

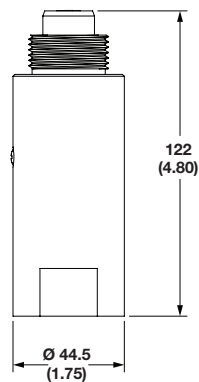
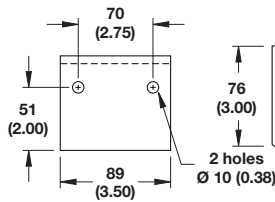

705/706 Adapter

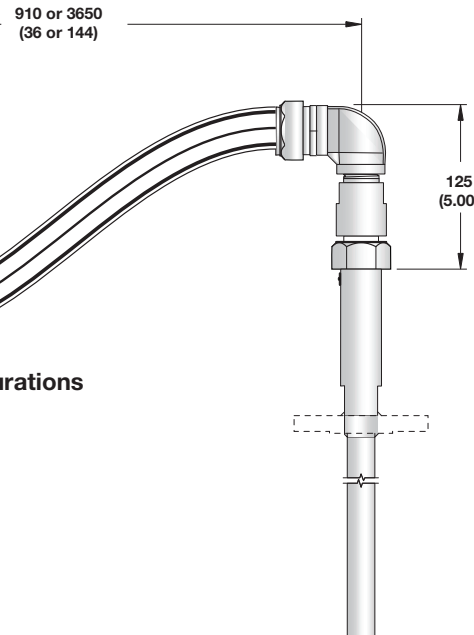

ELECTRICAL WIRING

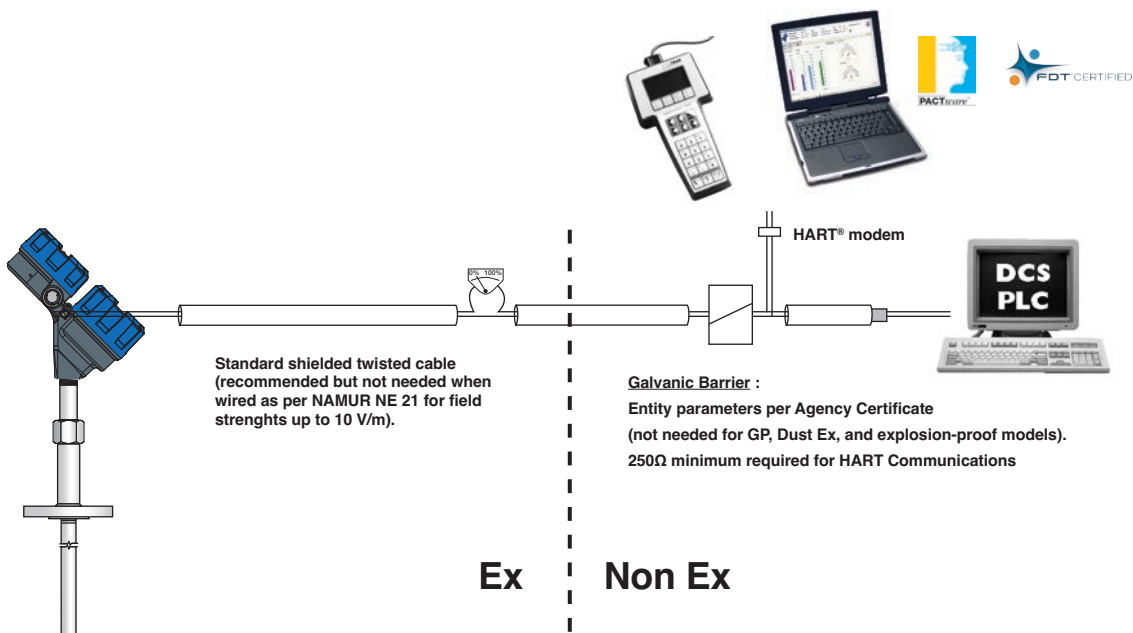

MODEL NUMBER

ENLARGED COAXIAL PROBE

1 | TECHNOLOGY

7	ECLIPSE GWR Probes - Model 706
---	--------------------------------

2 | MEASUREMENT SYSTEM

A	English (inches)
C	Metric (centimeters)

3 | CONFIGURATION/STYLE (RIGID)

D	Enlarged Coaxial, High Temp/High Pressure: Overfill w/Glass Seal (+450 °C/+850 °F) — Available only with 10th digit N or D
P	Enlarged Coaxial, High Pressure: Overfill w/Glass Seal (+200 °C/+400 °F) — Available only with 10th digit N or D
T	Enlarged Coaxial, Overfill Standard O-Ring Seal (+200 °C/+400 °F) — Not available with 10th digit N or D

4 5 | PROCESS CONNECTION – SIZE/TYPE (consult factory for other process connections)

Threaded

4 1	2" NPT Thread ①	4 2	2" BSP (G 2") Thread ①
-----	-----------------	-----	------------------------

ASME Flanges

4 3	2" 150# ASME RF ①	5M	3" 1500# ASME RTJ
4 4	2" 300# ANSI RF ①	5N	3" 2500# ASME RTJ
4 5	2" 600# ASME RF ①	6 3	4" 150# ASME RF
4 K	2" 600# ASME RTJ ①	6 4	4" 300# ASME RF
5 3	3" 150# ASME RF	6 5	4" 600# ASME RF
5 4	3" 300# ASME RF	6 6	4" 900# ASME RF
5 5	3" 600# ASME RF	6 7	4" 1500# ASME RF
56	3" 900# ASME RF	6 8	4" 2500# ASME RF
57	3" 1500# ASME RF	6K	4" 600# ASME RTJ
58	3" 2500# ASME RF	6L	4" 900# ASME RTJ
5K	3" 600# ASME RTJ	6M	4" 1500# ASME RTJ
5L	3" 900# ASME RTJ	6N	4" 2500# ASME RTJ

EN Flanges

D A	DN 50, PN 16	EN 1092-1 TYPE A ①	E H	DN 80, PN 320	EN 1092-1 TYPE B2
D B	DN 50, PN 25/40	EN 1092-1 TYPE A ①	E J	DN 80, PN 400	EN 1092-1 TYPE B2
D D	DN 50, PN 63	EN 1092-1 TYPE B2 ①	F A	DN 100, PN 16	EN 1092-1 TYPE A
D E	DN 50, PN 100	EN 1092-1 TYPE B2 ①	F B	DN 100, PN 25/40	EN 1092-1 TYPE A
E A	DN 80, PN 16	EN 1092-1 TYPE A	F D	DN 100, PN 63	EN 1092-1 TYPE B2
E B	DN 80, PN 25/40	EN 1092-1 TYPE A	F E	DN 100, PN 100	EN 1092-1 TYPE B2
E D	DN 80, PN 63	EN 1092-1 TYPE B2	F F	DN 100, PN 160	EN 1092-1 TYPE B2
E E	DN 80, PN 100	EN 1092-1 TYPE B2	F G	DN 100, PN 250	EN 1092-1 TYPE B2
E F	DN 80, PN 160	EN 1092-1 TYPE B2	F H	DN 100, PN 320	EN 1092-1 TYPE B2
E G	DN 80, PN 250	EN 1092-1 TYPE B2	F J	DN 100, PN 400	EN 1092-1 TYPE B2

Torque Tube Mating Flanges ②

T T	600# Fisher (249B/259B) in carbon steel — as per dimensions on page 19
T U	600# Fisher (249C) in stainless steel — as per dimensions on page 19
U T	600# Masoneilan flange in carbon steel — as per dimensions on page 19
U U	600# Masoneilan flange in stainless steel — as per dimensions on page 19

① Confirm mounting conditions/nozzle diameter to ensure sufficient clearance.

② Always check dimensions if ASME/EN flanges are not used.

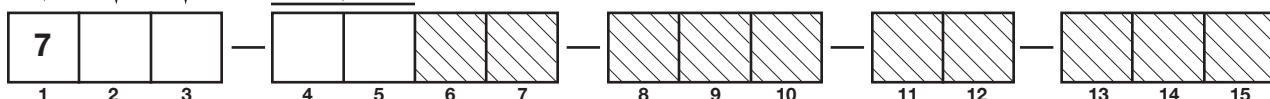

MODEL NUMBER CONTINUED

ENLARGED COAXIAL PROBE

6 | CONSTRUCTION CODES

0	Industrial
K	ASME B31.1
L	ASME B31.3
M	ASME B31.3 & NACE MR0175/MR0103 — NOT available with carbon steel flange
N	NACE MR0175/MR0103 — NOT available with carbon steel flange

7 | FLANGE OPTIONS — Offset flanges are available only with small coaxial probes

0	None
---	------

8 | MATERIAL OF CONSTRUCTION - FLANGE/NUT/ROD/INSULATION

A	316 SS/316L SS (Probe O.D. 45 mm (1.75"))
B	Hastelloy C (Probe O.D. 49 mm (1.93"))
C	Monel (Probe O.D. 49 mm (1.93"))
R	316 SS/316L SS with Carbon Steel Flange (Probe O.D. 45 mm (1.75"))
S	Hastelloy C with Carbon Steel Flange (Probe O.D. 49 mm (1.93"))
T	Monel with Carbon Steel Flange (Probe O.D. 49mm (1.93"))

9 | SPACER MATERIAL

1	TFE (+200 °C/+400 °F) — Available only with 3rd digit P or T — $\epsilon_r \geq 1.4$
2	PEEK HT — Available only with 3rd digit D (+345 °C/+650 °F) — $\epsilon_r \geq 1.4$
3	Ceramic (High Temp. >+425 °C/+800 °F) — Available only with 3rd digit D — $\epsilon_r \geq 2.0$
4	Duratron® CU60 PBI (+425 °C/+800 °F) — Available only with 3rd digit D — $\epsilon_r \geq 1.4$
5	None - with metal shorting rod — $\epsilon_r \geq 1.4$ — Future

10 | O-RING MATERIALS/SEAL OPTIONS

0	Viton® GFLT — Available only with 3rd digit T
2	Kalrez® 4079 — Available only with 3rd digit T
8	Aegis PF 128 (NACE) — Available only with 3rd digit T
A	Kalrez 6375 — Available only with 3rd digit T
B	HF Acid Probe — Available only with 3rd digit T and 8th digit C
D	None/Glass Ceramic Alloy (dual-seal design with annunciator fitting) — Available only with 3rd digit D or P
N	None/Glass Ceramic Alloy — Available only with 3rd digit D, P or S

11 | PROBE SIZE/ELEMENT TYPE/FLUSHING CONNECTION

0	Standard Enlarged Coaxial Probe
1	Standard Enlarged Coaxial Probe with Flushing Port

12 | SPECIAL OPTIONS ①

0	Single Length Probe (Non-Segmented)
1	1-piece Segmented Probe OD=64mm (2.5")
2	2-piece Segmented Probe OD=64mm (2.5")
3	3-piece Segmented Probe OD=64mm (2.5")
4	4-piece Segmented Probe OD=64mm (2.5")
5	5-piece Segmented Probe OD=64mm (2.5")
6	6-piece Segmented Probe OD=64mm (2.5")

① See page 34.

13 14 15 | INSERTION LENGTH ①

X X X	cm (030 – 999) inches (012 – 396)
-------	--------------------------------------

Unit of measure determined by 2nd digit of model number.

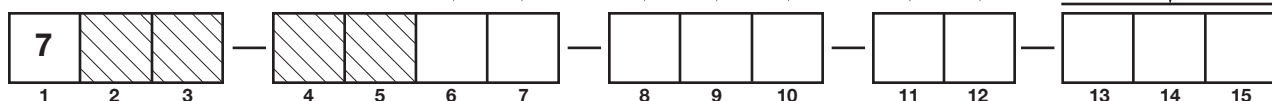

MODEL NUMBER

SMALL COAXIAL PROBE

1 | TECHNOLOGY

7	ECLIPSE GWR Probes - Model 706
---	--------------------------------

2 | MEASUREMENT SYSTEM

A	English (inches)
C	Metric (centimeters)

3 | CONFIGURATION/STYLE (RIGID)

D	Small Coaxial, High Temp/High Pressure: Overfill w/Glass Seal (+450 °C/+850 °F) — Available only with 10th digit N or D
P	Small Coaxial, High Pressure: Overfill w/Glass Seal (+200 °C/+400 °F) — Available only with 10th digit N or D
S	Coaxial, Saturated Steam (up to +425 °C/+800 °F) — Available only with 10th digit N, 9th digit 2, 3 or 5
T	Small Coaxial, Overfill Standard O-Ring Seal (+200 °C/+400 °F) — Not available with 10th digit N or D

4 5 | PROCESS CONNECTION – SIZE/TYPE (consult factory for other process connections)

Threaded

1 1	3/4" NPT Thread – Not available with 3rd Digit D	2 2	1" BSP (G 1") Thread – Not available with 3rd Digit D
4 1	2" NPT Thread – Not available with 3rd Digit S	4 2	2" BSP (G 2") Thread – Not available with 3rd Digit S

ASME Flanges

2 3	1" 150# ASME RF ① ③	3 8	1 1/2" 2500# ASME RF ③	5 3	3" 150# ASME RF	6 3	4" 150# ASME RF
2 4	1" 300# ASME RF ① ③	3 N	1 1/2" 2500# ASME RTJ ③	5 4	3" 300# ASME RF	6 4	4" 300# ASME RF
2 5	1" 600# ASME RF ① ③	4 3	2" 150# ASME RF	5 5	3" 600# ASME RF	6 5	4" 600# ASME RF
2 K	1" 600# ASME RTJ ① ③	4 4	2" 300# ASME RF	5 6	3" 900# ASME RF	6 6	4" 900# ASME RF
3 3	1 1/2" 150# ASME RF ③	4 5	2" 600# ASME RF	5 7	3" 1500# ASME RF	6 7	4" 1500# ASME RF
3 4	1 1/2" 300# ASME RF ③	4 7	2" 900/1500# ASME RF	5 8	3" 2500# ASME RF	6 8	4" 2500# ASME RF
3 5	1 1/2" 600# ASME RF ③	4 8	2" 2500# ASME RF	5 K	3" 600# ASME RTJ	6 K	4" 600# ASME RTJ
3 K	1 1/2" 600# ASME RTJ ③	4 K	2" 600# ASME RTJ	5 L	3" 900# ASME RTJ	6 L	4" 900# ASME RTJ
3 7	1 1/2" 900/1500# ASME RF ③	4 M	2" 900/1500# ASME RTJ	5 M	3" 1500# ASME RTJ	6 M	4" 1500# ASME RTJ
3 M	1 1/2" 900/1500# ASME E RTJ ③	4 N	2" 2500# ASME RTJ	5 N	3" 2500# ASME RTJ	6 N	4" 2500# ASME RTJ

EN Flanges

B B	DN 25, PN 16/25/40 EN 1092-1 TYPE A ① ③	E A	DN 80, PN 16 EN 1092-1 TYPE A
B C	DN 25, PN 63/100 EN 1092-1 TYPE B2 ① ③	E B	DN 80, PN 25/40 EN 1092-1 TYPE A
C B	DN 40, PN 16/25/40 EN 1092-1 TYPE A ③	E D	DN 80, PN 63 EN 1092-1 TYPE B2
C C	DN 40, PN 63/100 EN 1092-1 TYPE B2 ③	E E	DN 80, PN 100 EN 1092-1 TYPE B2
C F	DN 40, PN 160 EN 1092-1 TYPE B2 ③	E F	DN 80, PN 160 EN 1092-1 TYPE B2
C G	DN 40, PN 250 EN 1092-1 TYPE B2 ③	E G	DN 80, PN 250 EN 1092-1 TYPE B2
C H	DN 40, PN 320 EN 1092-1 TYPE B2 ③	E H	DN 80, PN 320 EN 1092-1 TYPE B2
C J	DN 40, PN 400 EN 1092-1 TYPE B2 ③	E J	DN 80, PN 400 EN 1092-1 TYPE B2
D A	DN 50, PN 16 EN 1092-1 TYPE A	F A	DN 100, PN 16 EN 1092-1 TYPE A
D B	DN 50, PN 25/40 EN 1092-1 TYPE A	F B	DN 100, PN 25/40 EN 1092-1 TYPE A
D D	DN 50, PN 63 EN 1092-1 TYPE B2	F D	DN 100, PN 63 EN 1092-1 TYPE B2
D E	DN 50, PN 100 EN 1092-1 TYPE B2	F E	DN 100, PN 100 EN 1092-1 TYPE B2
D F	DN 50, PN 160 EN 1092-1 TYPE B2	F F	DN 100, PN 160 EN 1092-1 TYPE B2
D G	DN 50, PN 250 EN 1092-1 TYPE B2	F G	DN 100, PN 250 EN 1092-1 TYPE B2
D H	DN 50, PN 320 EN 1092-1 TYPE B2	F H	DN 100, PN 320 EN 1092-1 TYPE B2
D J	DN 50, PN 400 EN 1092-1 TYPE B2	F J	DN 100, PN 400 EN 1092-1 TYPE B2

Torque Tube Mating Flanges ②

T T	600# Fisher (249B/259B) in carbon steel — as per dimensions on page 19
T U	600# Fisher (249C) in stainless steel — as per dimensions on page 19
U T	600# Masoneilan flange in carbon steel — as per dimensions on page 19
U U	600# Masoneilan flange in stainless steel — as per dimensions on page 19

- ① Confirm mounting conditions/nozzle diameter to ensure sufficient clearance.
- ② Always check dimensions if ASME/EN flanges are not used.
- ③ Not available with 3rd digit D or P.

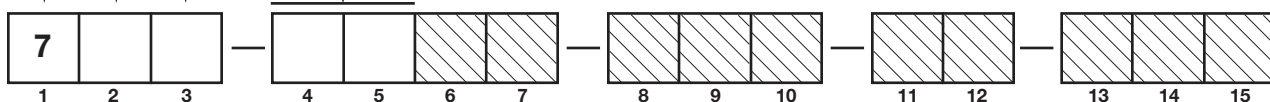

MODEL NUMBER CONTINUED

SMALL COAXIAL PROBE

6 | CONSTRUCTION CODES

0	Industrial
K	ASME B31.1 — NOT available with 4th digits T or U
L	ASME B31.3
M	ASME B31.3 & NACE MR0175/MR0103 — NOT available with carbon steel flange
N	NACE MR0175/MR0103 — NOT available with carbon steel flange

7 | FLANGE OPTIONS — Offset flanges are only available with small coaxial probes

0	None
1	Offset (For use with AURORA) — Available only with 3rd digit P, S or T and 4th digit 6
2	Offset with 1/2" NPT Vent (For use with AURORA) — Available only with 3rd digit P, S or T and 4th digit 6
3	Offset with 3/4" NPT Vent (For use with AURORA) — Available only with 3rd digit P, S or T and 4th digit 6

8 | MATERIAL OF CONSTRUCTION - FLANGE/NUT/ROD/INSULATION

A	316 SS/316L SS
B	Hastelloy C
C	Monel — Not available with 3rd Digit S
R	316 SS/316L SS with Carbon Steel Flange
S	Hastelloy C with Carbon Steel Flange
T	Monel with Carbon Steel Flange — Not available with 3rd Digit S

9 | SPACER MATERIAL

1	TFE (+200 °C/+400 °F) — Available only with 3rd digit P or T — $\epsilon_r \geq 1.4$
2	PEEK HT — Available only with 3rd digit D — $\epsilon_r \geq 1.4$ (+345 °C/+650 °F) or S (+300 °C/+575 °F)
3	Ceramic (+425 °C/+800 °F) — Available only with 3rd digit D with $\epsilon_r \geq 2.0$ or with 3rd digit S ①
5	None - Single bottom metal spacer — Available only with 3rd digit S and 11th digit A or B ①

① Not available with 5th digit 1 or 2.

10 | O-RING MATERIALS/SEAL OPTIONS

0	Viton® GFLT — Available only with 3rd digit T
2	Kalrez® 4079 — Available only with 3rd digit T
8	Aegis PF 128 (NACE) — Available only with 3rd digit T
A	Kalrez 6375 — Available only with 3rd digit T
B	HF Acid Probe — Available only with 3rd digit T and 8th digit C
D	None/Glass Ceramic Alloy (dual-seal design with annunciator fitting) - Available only with 3rd digit D or P
N	None/Glass Ceramic Alloy — Available only with 3rd digit D, P or S

11 | PROBE SIZE/ELEMENT TYPE/FLUSHING CONNECTION

2	Small Coaxial (0.875 inches/22 mm)
A	Medium Coaxial (1.25 inches/32 mm) — Available only with 3rd digit S ②
B	Large Coaxial (1.62 inches/42 mm) — Available only with 3rd digit S ③

② 244 cm (96 inches) maximum length.

③ 305 cm (120 inches) maximum length.

12 | SPECIAL OPTIONS

0	Single Length Probe (Non-Segmented)
---	-------------------------------------

13 14 15 | INSERTION LENGTH

X X X	cm (030 – 610) inches (012 – 240)
-------	--------------------------------------

Unit of measure determined by 2nd digit of model number.

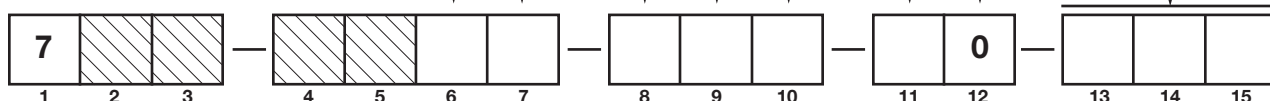

MODEL NUMBER

CAGED PROBE

1 | TECHNOLOGY

7	ECLIPSE GWR Probes - Model 706
---	--------------------------------

2 | MEASUREMENT SYSTEM

A	English (inches)
C	Metric (centimeters)

3 | CONFIGURATION/STYLE (RIGID)

G	Overfill Caged Rigid Probe for use in chambers +200 °C (+400 °F)
J	Overfill Caged High Temp/High Pressure Probe with Glass Seal for use in chambers +450 °C (+850 °F)
L	Overfill Caged High Pressure Probe with Glass Seal for use in chambers +200 °C (+400 °F)

4 5 | PROCESS CONNECTION – SIZE/TYPE (consult factory for other process connections) ①

ASME Flanges

4 3	2"	150# ASME RF	5 4	3"	300# ASME RF	6 3	4"	150# ASME RF
4 4	2"	300# ASME RF	5 5	3"	600# ASME RF	6 4	4"	300# ASME RF
4 5	2"	600# ASME RF	5 6	3"	900# ASME RF	6 5	4"	600# ASME RF
4 7	2"	900/1500# ASME RF	5 7	3"	1500# ASME RF	6 6	4"	900# ASME RF
4 8	2"	2500# ASME RF	5 8	3"	2500# ASME RF	6 7	4"	1500# ASME RF
4 K	2"	600# ASME RTJ	5 K	3"	600# ASME RTJ	6 8	4"	2500# ASME RF
4 M	2"	900/1500# ASME RTJ	5 L	3"	900# ASME RTJ	6 K	4"	600# ASME RTJ
4 N	2"	2500# ASME RTJ	5 M	3"	1500# ASME RTJ	6 L	4"	900# ASME RTJ
5 3	3"	150# ASME RF	5 N	3"	2500# ASME RTJ	6 M	4"	1500# ASME RTJ
						6 N	4"	2500# ASME RTJ

EN Flanges

D A	DN 50, PN 16	EN 1092-1 TYPE A	E F	DN 80, PN 160	EN 1092-1 TYPE B2
D B	DN 50, PN 25/40	EN 1092-1 TYPE A	E G	DN 80, PN 250	EN 1092-1 TYPE B2
D D	DN 50, PN 63	EN 1092-1 TYPE B2	E H	DN 80, PN 320	EN 1092-1 TYPE B2
D E	DN 50, PN 100	EN 1092-1 TYPE B2	E J	DN 80, PN 400	EN 1092-1 TYPE B2
D F	DN 50, PN 160	EN 1092-1 TYPE B2	F A	DN 100, PN 16	EN 1092-1 TYPE A
D G	DN 50, PN 250	EN 1092-1 TYPE B2	F B	DN 100, PN 25/40	EN 1092-1 TYPE A
D H	DN 50, PN 320	EN 1092-1 TYPE B2	F D	DN 100, PN 63	EN 1092-1 TYPE B2
D J	DN 50, PN 400	EN 1092-1 TYPE B2	F E	DN 100, PN 100	EN 1092-1 TYPE B2
E A	DN 80, PN 16	EN 1092-1 TYPE A	F F	DN 100, PN 160	EN 1092-1 TYPE B2
E B	DN 80, PN 25/40	EN 1092-1 TYPE A	F G	DN 100, PN 250	EN 1092-1 TYPE B2
E D	DN 80, PN 63	EN 1092-1 TYPE B2	F H	DN 100, PN 320	EN 1092-1 TYPE B2
E E	DN 80, PN 100	EN 1092-1 TYPE B2	F J	DN 100, PN 400	EN 1092-1 TYPE B2

Torque Tube Mating Flanges ②

T T	600# Fisher (249B/259B) in carbon steel — as per dimensions on page 19
T U	600# Fisher (249C) in stainless steel — as per dimensions on page 19
U T	600# Masoneilan flange in carbon steel — as per dimensions on page 19
U U	600# Masoneilan flange in stainless steel — as per dimensions on page 19

- ① Confirm mounting conditions/nozzle diameter to ensure sufficient clearance.
- ② Always check dimensions if ASME/EN flanges are not used.

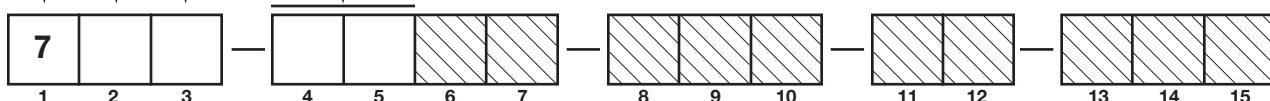

MODEL NUMBER CONTINUED

CAGED PROBE

6 | CONSTRUCTION CODES

0	Industrial
K	ASME B31.1
L	ASME B31.3
M	ASME B31.3 & NACE MR0175/MR0103 — NOT available with carbon steel flange
N	NACE MR0175/MR0103 — NOT available with carbon steel flange

7 | FLANGE OPTIONS

0	None
1	Offset (For use with AURORA) — Available only with 3rd digit G and J and 4th digit 6
2	Offset with 1/2" NPT Vent (For use with AURORA) — Available only with 3rd digit G and J and 4th digit 6
3	Offset with 3/4" NPT Vent (For use with AURORA) — Available only with 3rd digit G and J and 4th digit 6

8 | MATERIAL OF CONSTRUCTION - MFG/NUT/ROD/INSULATION

A	316 SS/316L SS
B	Hastelloy C
C	Monel
R	316 SS/316L SS with Carbon Steel Flange
S	Hastelloy C with Carbon Steel Flange
T	Monel with Carbon Steel Flange

9 | SPACER MATERIAL

2	PEEK HT (+345 °C/+650 °F)
3	Ceramic (High Temp.>+425 °C/+800 °F) — Available only with 3rd digit J
4	Duratron® CU60 PBI (+425 °C/+800 °F) — Available only with 3rd digit J

10 | O-RING MATERIALS/SEAL OPTIONS

0	Viton® GFLT — Not available with 3rd digit J or L
2	Kalrez 4079 — Not available with 3rd digit J or L
8	Aegis PF 128 (NACE) — Not available with 3rd digit J or L
A	Kalrez 6375 — Not available with 3rd digit J or L
B	HF Acid Probe — Available only with 3rd digit G and 8th digit C
D	None/Glass Ceramic Alloy (Dual Seal Design with annunciator fitting) — Not available with 3rd digit G
N	None/Glass Ceramic Alloy — Not available with 3rd digit G

11 | PROBE SIZE/ELEMENT TYPE/FLUSHING CONNECTION

0	None
---	------

12 | SPECIAL OPTIONS ①

1	Single Length Removable Probe
2	2-piece Segmented Probe
3	3-piece Segmented Probe
4	4-piece Segmented Probe

① See page 34

13 14 15 | INSERTION LENGTH ①

X X X	cm (030 – 732) inches (012 – 288)
-------	--------------------------------------

Unit of measure determined by 2nd digit of model number.

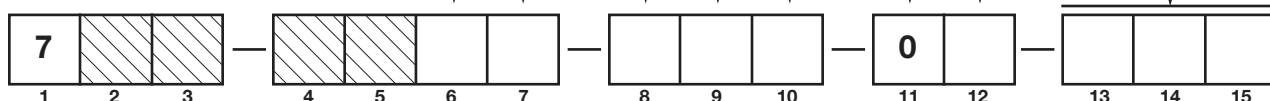

MODEL NUMBER

SINGLE ROD RIGID PROBE

1 | TECHNOLOGY

7	ECLIPSE GWR Probes - Model 706
---	--------------------------------

2 | MEASUREMENT SYSTEM

A	English (inches)
C	Metric (centimeters)

3 | CONFIGURATION/STYLE (RIGID)

F	Single Rod, Standard (+400 °F/200 °C) for in-tank applications — NOT available with 10th digit N or D
M	Single Rod, High Pressure Probe with glass seal (+200 °C/+400 °F), for in-tank applications. — Available only with 10th Digit N or D
N	Single Rod, High Temp/High Pressure with glass seal (+450 °C/+850 °F), for in-tank applications. — Available only with 10th Digit N or D

4 5 | PROCESS CONNECTION – SIZE/TYPE (consult factory for other process connections) ①

Threaded

1 1	3/4" NPT Thread ②
2 1	1" NPT Thread ②
4 1	2" NPT Thread

2 2	1" BSP (G 1") Thread ②
4 2	2" BSP (G 2") Thread

ASME Flanges

3 3	1 1/2" 150# ASME RF ①③
3 4	1 1/2" 300# ASME RF ①③
3 5	1 1/2" 600# ASME RF ①③
3 7	1 1/2" 900/1500# ASME RF④
3 K	1 1/2" 600# ASME RTJ ④
3 M	1 1/2" 900/1500# ASME RTJ ④
4 3	2" 150# ASME RF ①
4 4	2" 300# ASME RF ①
4 5	2" 600# ASME RF ①
4 7	2" 900/1500# ASME RF ④
4 8	2" 2500# ASME RF ④
4 K	2" 600# ASME RTJ ④
4 M	2" 900/1500# ASME RTJ ④

4 N	2" 2500# ASME RTJ ④
5 3	3" 150# ASME RF
5 4	3" 300# ASME RF
5 5	3" 600# ASME RF
5 6	3" 900# ASME RF ④
5 7	3" 1500# ASME RF ④
5 8	3" 2500# ASME RF ④
5 K	3" 600# ASME RTJ ④
5 L	3" 900# ASME RTJ ④
5 M	3" 1500# ASME RTJ ④

5 N	3" 2500# ASME RTJ ④
6 3	4" 150# ASME RF
6 4	4" 300# ASME RF
6 5	4" 600# ASME RF
6 6	4" 900# ASME RF ④
6 7	4" 1500# ASME RF ④
6 8	4" 2500# ASME RF ④
6 K	4" 600# ASME RTJ ④
6 L	4" 900# ASME RTJ ④
6 M	4" 1500# ASME RTJ ④
6 N	4" 2500# ASME RTJ ④

EN Flanges

C B	DN 40, PN 16/25/40 EN 1092-1 TYPE A ①③
C C	DN 40, PN 63/100 EN 1092-1 TYPE B2 ①③
C F	DN 40, PN 160 EN 1092-1 TYPE B2 ①③④
C G	DN 40, PN 250 EN 1092-1 TYPE B2 ①③④
D A	DN 50, PN 16 EN 1092-1 TYPE A ①
D B	DN 50, PN 25/40 EN 1092-1 TYPE A ①
D D	DN 50, PN 63 EN 1092-1 TYPE B2 ①
D E	DN 50, PN 100 EN 1092-1 TYPE B2 ①
D F	DN 50, PN 160 EN 1092-1 TYPE B2 ④
D G	DN 50, PN 250 EN 1092-1 TYPE B2 ④
D H	DN 50, PN 320 EN 1092-1 TYPE B2 ④
D J	DN 50, PN 400 EN 1092-1 TYPE B2 ④
E A	DN 80, PN 16 EN 1092-1 TYPE A ①
E B	DN 80, PN 25/40 EN 1092-1 TYPE A

E D	DN 80, PN 63 EN 1092-1 TYPE B2
E E	DN 80, PN 100 EN 1092-1 TYPE B2
E F	DN 80, PN 160 EN 1092-1 TYPE B2 ④
E G	DN 80, PN 250 EN 1092-1 TYPE B2 ④
E H	DN 80, PN 320 EN 1092-1 TYPE B2 ④
E J	DN 80, PN 400 EN 1092-1 TYPE B2 ④
F A	DN 100, PN 16 EN 1092-1 TYPE A
F B	DN 100, PN 25/40 EN 1092-1 TYPE A
F D	DN 100, PN 63 EN 1092-1 TYPE B2
F E	DN 100, PN 100 EN 1092-1 TYPE B2
F F	DN 100, PN 160 EN 1092-1 TYPE B2 ④
F G	DN 100, PN 250 EN 1092-1 TYPE B2 ④
F H	DN 100, PN 320 EN 1092-1 TYPE B2 ④
F J	DN 100, PN 400 EN 1092-1 TYPE B2 ④

- ① Confirm mounting conditions/nozzle diameter to ensure sufficient clearance.
- ② Not available with 3rd Digit N or 8th Digit P.
- ③ Not available with 3rd digit M or N.
- ④ Not available with 3rd digit F.

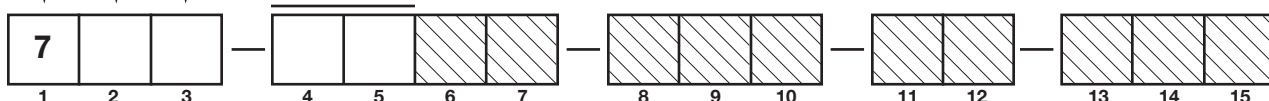

MODEL NUMBER CONTINUED

SINGLE ROD RIGID PROBE

6 | CONSTRUCTION CODES

0	Industrial
K	ASME B31.1
L	ASME B31.3
M	ASME B31.3 & NACE MR0175/MR0103 — NOT available with carbon steel flange
N	NACE MR0175/MR0103 — NOT available with carbon steel flange

7 | FLANGE OPTIONS

0	None
---	------

8 | MATERIAL OF CONSTRUCTION - MFG/NUT/ROD/INSULATION

A	316 SS/316L SS
B	Hastelloy C
C	Monel
F	Faced Flange, PFA coated wetted surfaces — Available only with Digit 3rd digit F
P	PFA coated rod — Available only with Digit 3rd digit F
R	316 SS/316L SS with Carbon Steel Flange
S	Hastelloy C with Carbon Steel Flange
T	Monel with Carbon Steel Flange

9 | SPACER MATERIAL

0	None – Not available with 3rd Digit N
2	PEEK HT (+345 °C/+650 °F) — Available only with 3rd digit N
3	Ceramic (High Temp.>+425 °C/+800 °F) — Available only with 3rd digit N
4	Duratron® CU60 PBI (+425 °C/+800 °F) — Available only with 3rd digit N

10 | O-RING MATERIALS/SEAL OPTIONS

0	Viton® GFLT — Not available with 3rd digit M or N
2	Kalrez 4079 — Not available with 3rd digit M or N
8	Aegis PF 128 (NACE) — Not available with 3rd digit M or N
A	Kalrez 6375 — Not available with 3rd digit M or N
D	None/Glass Ceramic Alloy Dual Seal with annunciator fitting — Not available with 3rd digit F
N	None/Glass Ceramic Alloy Dual Seal — Not available with 3rd digit F

11 | PROBE SIZE/ELEMENT TYPE/FLUSHING CONNECTION

0	Standard Single Rod
---	---------------------

12 | SPECIAL OPTIONS

0	Non-Removable Rod — Available only with PFA Coated Probes(8th digit F or P)
1	Removable Rod — Not available with PFA Coated Probes(8th Digit F or P)
2	Two-piece segmented probe
3	Three-piece segmented probe
4	Four-piece segmented probe
5	Five-piece segmented probe
6	Six-piece segmented probe

13 14 15 | INSERTION LENGTH

X X X	cm (030 – 732) inches (012 – 288) maximum 610 cm (240 inches) when 8th digit = F or P
-------	--

Unit of measure determined by 2nd digit of model number.

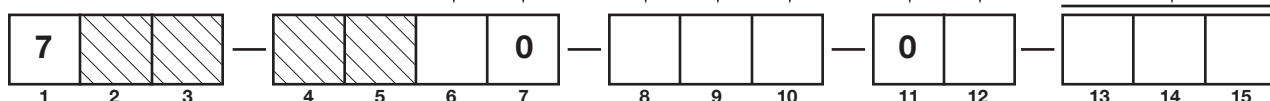

MODEL NUMBER

SINGLE FLEXIBLE PROBE

1 | TECHNOLOGY

7	ECLIPSE GWR Probes - Model 706
---	--------------------------------

2 | MEASUREMENT SYSTEM

A	English (inches)
C	Metric (centimeters)

3 | SPECIALTY FLEXIBLE PROBES

1	Single Cable Flexible standard for in-tank applications (+200 °C/+400 °F)
2	Single Cable Flexible Light Duty Bulk Solids
3	Single Cable Flexible HP for in-tank applications (+200 °C/+400 °F)
6	Single Cable Flexible HTHP for chamber applications (+450 °C/+850 °F)

4 5 | PROCESS CONNECTION – SIZE/TYPE (consult factory for other process connections)

Threaded

4 1	2" NPT Thread (not available with the 7y6)	4 2	2" BSP (G 2") Thread (not available with the 7y6)
-----	--	-----	---

ASME Flanges

4 3	2" 150# ASME RF ①	5 3	3" 150# ASME RF	6 3	4" 150# ASME RF
4 4	2" 300# ASME RF ①	5 4	3" 300# ASME RF	6 4	4" 300# ASME RF
4 5	2" 600# ASME RF ①	5 5	3" 600# ASME RF	6 5	4" 600# ASME RF
4 7	2" 900/1500# ASME RF	5 6	3" 900# ASME RF	6 6	4" 900# ASME RF ②
4 8	2" 2500# ASME RF	5 7	3" 1500# ASME RF	6 7	4" 1500# ASME RF ②
4 K	2" 600# ASME RTJ	5 8	3" 2500# ASME RF	6 8	4" 2500# ASME RF ②
4 M	2" 900/1500# ASME RTJ	5 K	3" 600# ASME RTJ	6 K	4" 600# ASME RTJ ②
4 N	2" 2500# ASME RTJ	5 L	3" 900# ASME RTJ	6 L	4" 900# ASME RTJ ②
		5 M	3" 1500# ASME RTJ	6 M	4" 1500# ASME RTJ ②
		5 N	3" 2500# ASME RTJ	6 N	4" 2500# ASME RTJ ②

EN Flanges

D A	DN 50, PN 16	EN 1092-1 TYPE A ①	E F	DN 80, PN 160	EN 1092-1 TYPE B2 ②
D B	DN 50, PN 25/40	EN 1092-1 TYPE A ①	E G	DN 80, PN 250	EN 1092-1 TYPE B2 ②
D D	DN 50, PN 63	EN 1092-1 TYPE B2 ①	E H	DN 80, PN 320	EN 1092-1 TYPE B2 ②
D E	DN 50, PN 100	EN 1092-1 TYPE B2 ①	E J	DN 80, PN 400	EN 1092-1 TYPE B2 ②
D F	DN 50, PN 160	EN 1092-1 TYPE B2 ②	F A	DN 100, PN 16	EN 1092-1 TYPE A
D G	DN 50, PN 250	EN 1092-1 TYPE B2 ②	F B	DN 100, PN 25/40	EN 1092-1 TYPE A
D H	DN 50, PN 320	EN 1092-1 TYPE B2 ②	F D	DN 100, PN 63	EN 1092-1 TYPE B2
D J	DN 50, PN 400	EN 1092-1 TYPE B2 ②	F E	DN 100, PN 100	EN 1092-1 TYPE B2
E A	DN 80, PN 16	EN 1092-1 TYPE A ①	F F	DN 100, PN 160	EN 1092-1 TYPE B2 ②
E B	DN 80, PN 25/40	EN 1092-1 TYPE A	F G	DN 100, PN 250	EN 1092-1 TYPE B2 ②
E D	DN 80, PN 63	EN 1092-1 TYPE B2	F H	DN 100, PN 320	EN 1092-1 TYPE B2 ②
E E	DN 80, PN 100	EN 1092-1 TYPE B2	F J	DN 100, PN 400	EN 1092-1 TYPE B2 ②

① Confirm mounting conditions/nozzle diameter to ensure sufficient clearance.

② Available only with 3rd Digit 3 or 6.

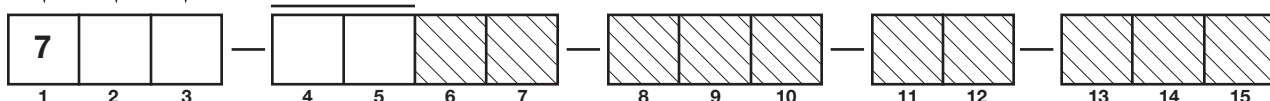

MODEL NUMBER CONTINUED

SINGLE FLEXIBLE PROBE

6 | CONSTRUCTION CODES

0	Industrial
---	------------

7 | FLANGE OPTIONS

0	None
---	------

8 | MATERIAL OF CONSTRUCTION - MFG/NUT/ROD/INSULATION

A	316 SS/316L SS
F	Faced Flange, PFA Coated Wetted Surfaces — Available only with 3rd digit 1
P	PFA Coated 316/316L SS Cable — Available only with 3rd digit 1
R	316 SS/316L SS with Carbon Steel Flange

9 | SPACER/WEIGHT OPTIONS

0	No Spacer — Not available with 3rd digit 3
1	PTFE Spacer — Available only with 3rd digit 3
4	Duratron® CU60 PBI Spacer — Available only with 3rd digit 6
5	Metal Weight — Available only with 3rd digit 3

10 | O-RING MATERIALS/SEAL OPTIONS

0	Viton® GFLT
2	Kalrez 4079
8	Aegis PF 128 (NACE)
A	Kalrez 6375
D	Glass Ceramic Alloy Dual Seal with annunciator fitting — Available only with 3rd digit 3 or 6
N	None/Glass Ceramic Alloy Dual Seal — Available only with 3rd digit 3 or 6

11 | PROBE SIZE/ELEMENT TYPE/FLUSHING CONNECTION

3	Flexible Cable Probe
---	----------------------

12 | SPECIAL OPTIONS

0	Non-removable Probe Cable — Available only with 3rd digit 2 or 8th digit F
1	Removable Single-piece Probe Cable — Available only with 3rd digit 1, 3, 6 and 8th digit NOT F

13 14 15 | INSERTION LENGTH

X X X	meters (001 – 030) feet (003 – 100)
-------	--

unit of measure determined by 2nd digit of model number

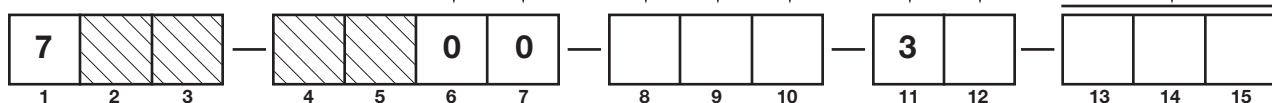

SEGMENTED PROBE OPTIONS

12th DIGIT OF MODEL NUMBER

Probe Model	Single Length	One Segment	Two Segments	Three Segments	Four Segments	Five Segments	Six Segments
Coaxial Models 7yD, 7yP and 7yT (Enlarged versions only) (3", DN 80 Process Connections and larger)	30 – 610 cm (12 – 240")	60 – 182 cm (24 – 72")	120 – 365 cm (48 – 144")	180 – 548 cm (72 – 216")	240 – 731 cm (96 – 288")	305 – 914 cm (120 – 360")	365 – 999 cm (144 – 396")
Caged Models 7yG, 7yL and 7yJ	Not Available	30 – 305 cm (12 – 120")	60 – 610 cm (24 – 240")	90 – 732 cm (36 – 288")	120 – 732 cm (48 – 288")	Not Available	Not Available

NOTE: Segments will be evenly divided over the length of the probe.

COAXIAL PROBE DIMENSIONS

mm (INCHES)

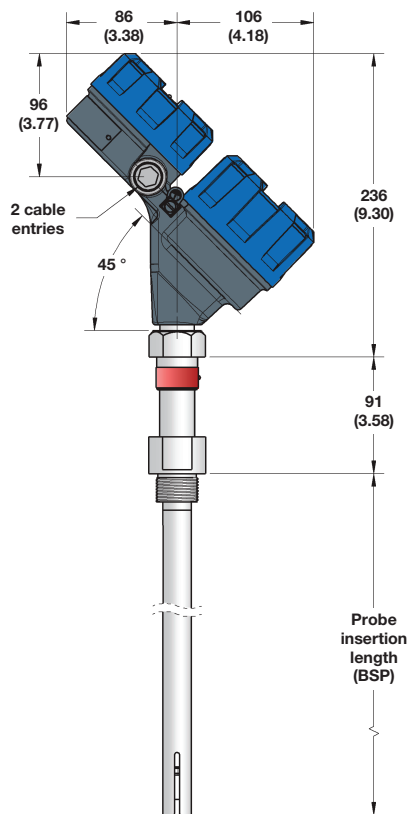

Model 7yT
with BSP threaded connection

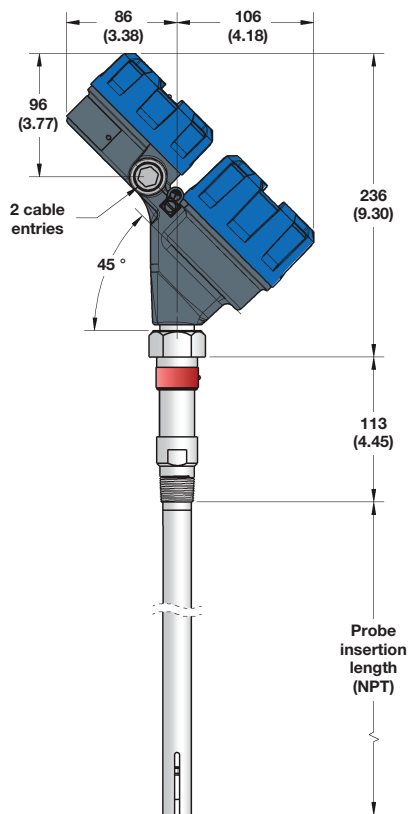

Model 7yT
with NPT threaded connection

COAXIAL PROBE DIMENSIONS

mm (INCHES)

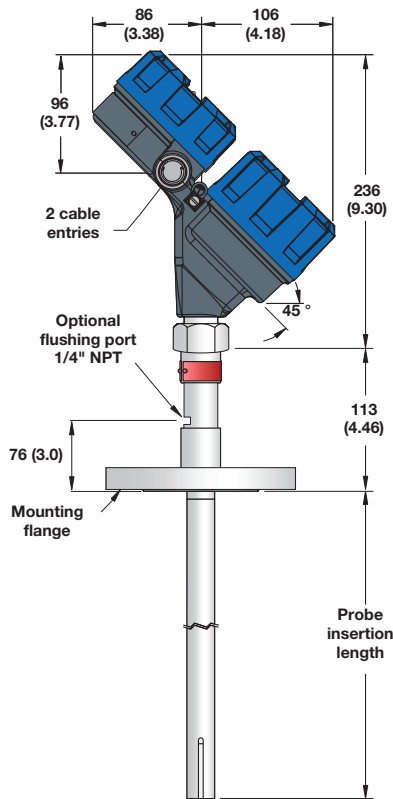

Model 7yT
with flanged connection

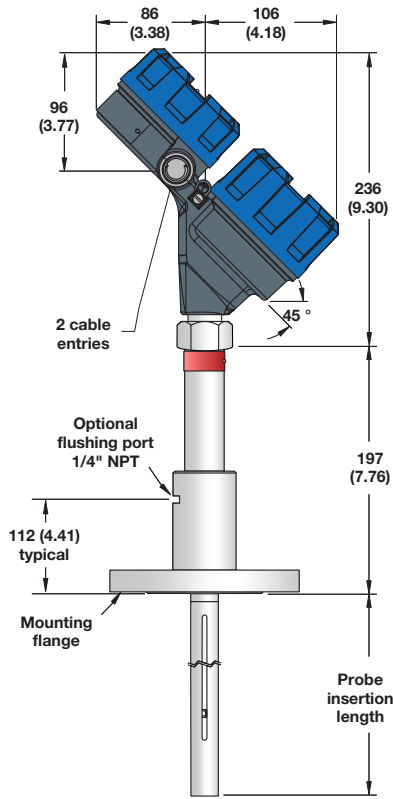

Model 7yP
with flanged connection

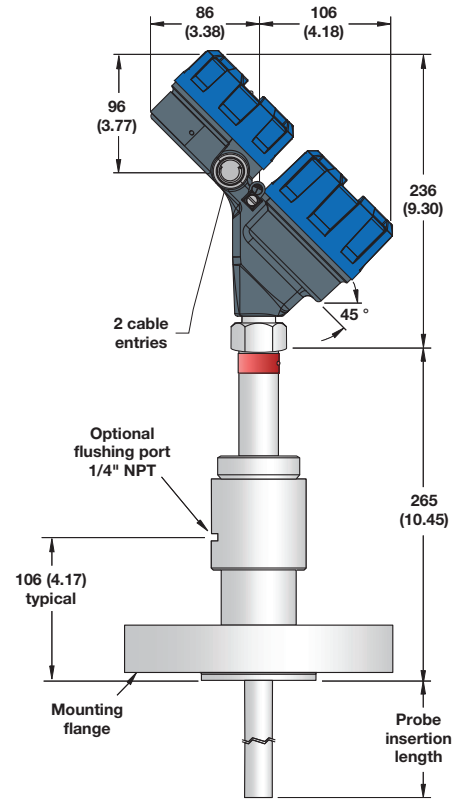

Model 7yD
with flanged connection

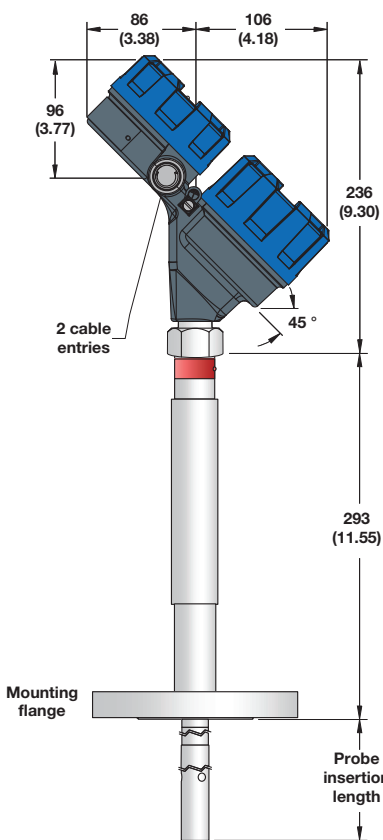

Model 7yS
with flanged connection

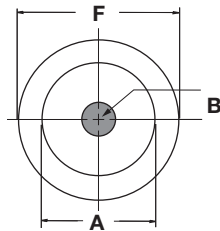

Model 7yS
Coaxial GWR Probe,
End View

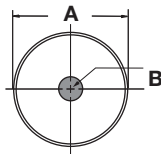

Coaxial GWR Probe,
End View

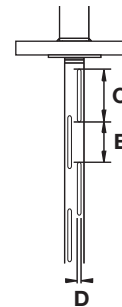

Coaxial Probe Slots

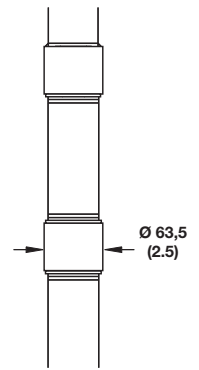

Segmented Enlarged
Coaxial Probe

mm (inches)

Dim.	Small Diameter	Medium Diameter	Large Diameter	Enlarged (standard)
A	22,5 (0.88)	31,75 (1.25)	41,1 (1.62)	45 (1.75) - SST 49 (1.92) - HC and Monel
B	8 (0.31)	10 (0.38) maximum	13 (0.50) maximum	16 (0.63) maximum
C	100 (4.08)	153 (6.05)	153 (6.05)	153 (6.05)
D	4 (0.15)	8 (0.30)	8 (0.30)	8 (0.30)
E	96 (3.78)	138 (5.45)	138 (5.45)	138 (5.45)
F	31,75 (1.25)	—	—	—

CAGED PROBE DIMENSIONS

mm (INCHES)

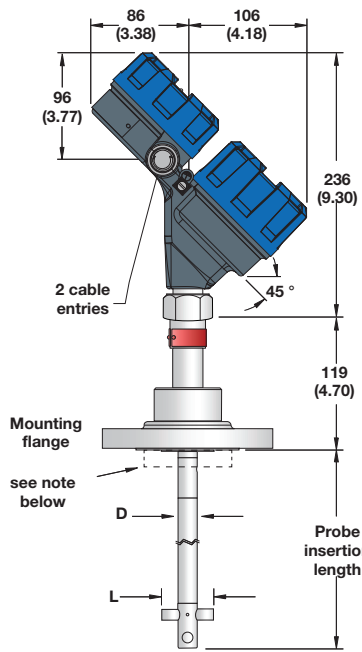

Model 7yG
with flanged connection

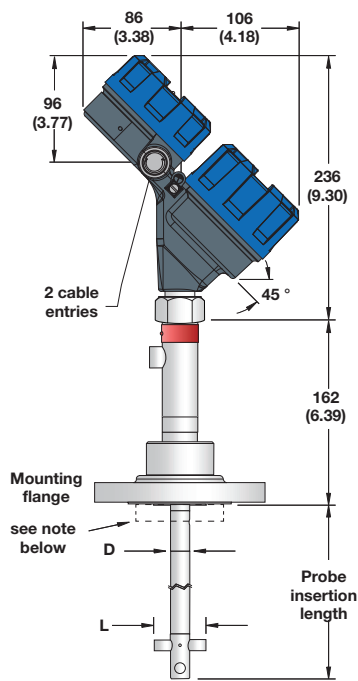

Model 7yL
with flanged connection

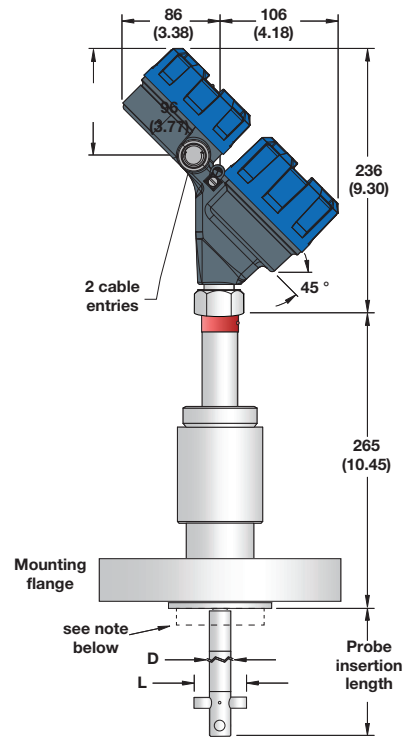

Model 7yJ
with flanged connection

Cage Size	Probe Rod Diameter (D)	Spacer Length (L)
2"	13 to 19 mm (0.5 to 0.75")	46 mm (1.82")
3"	19 to 29 mm (0.75 to 1.13")	67 mm (2.64")
4"	27 to 38 mm (1.05 to 1.50")	91 mm (3.60")

NOTE: Caged Probes (7yG, 7yL, 7yJ) with 2", 3" or 4" (DN50, DN80 or DN100) nozzle are equipped with a fix outer matching ring welded to flange face. Default value is for nozzle sizes SCH 80 or equal. For small inside diameter please specify per below table.

Nozzle Size	ØL2		
	SCH 80 (or smaller)	SCH 160	SCH XXS
2"	47.1 mm	N.A.	N.A.
3"	71 mm	63.5 mm	55.5 mm
4"	94.5 mm	84 mm	76.2 mm
DEFAULT			

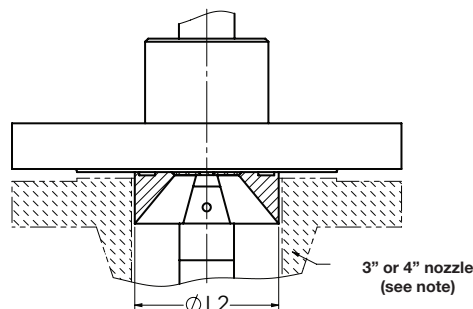
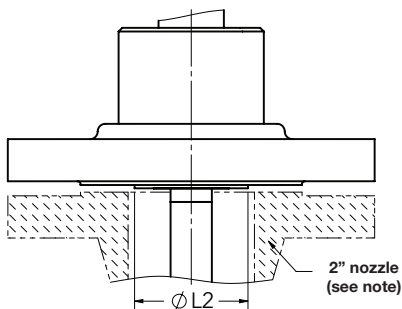

SINGLE ROD RIGID PROBE DIMENSIONS

mm (INCHES)

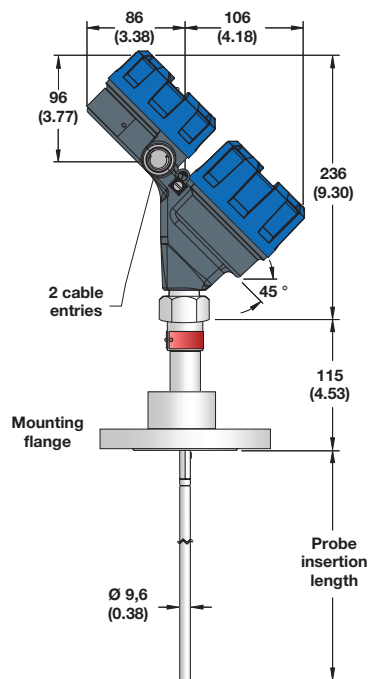

Model 7yF
with flanged connection

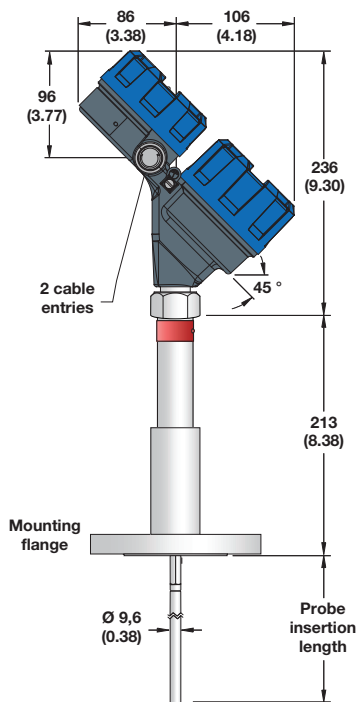

Model 7yM
with flanged connection

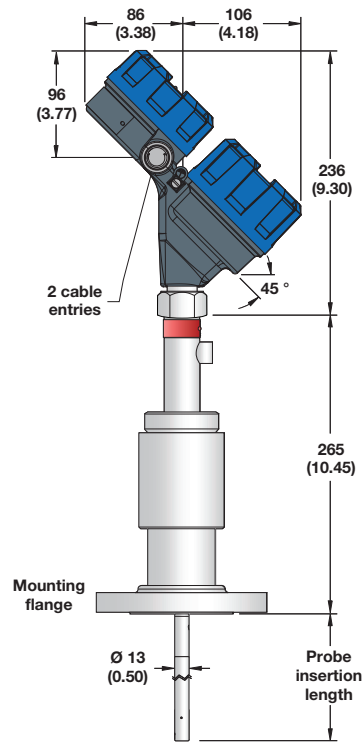

Model 7yN
with flanged connection

SINGLE FLEXIBLE PROBE DIMENSIONS

mm (INCHES)

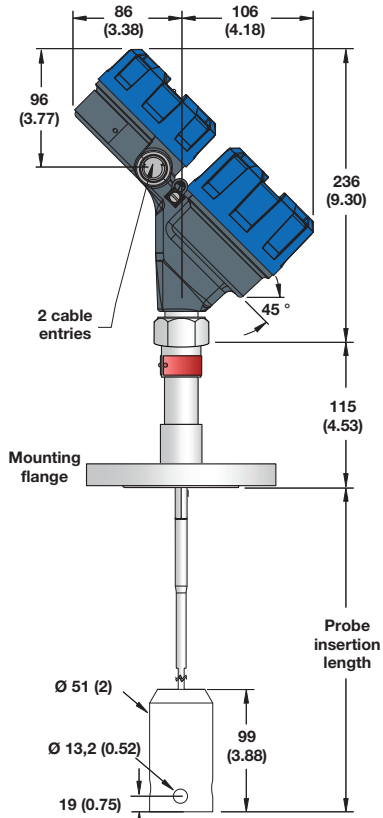

**Model 7y1
with flanged connection**

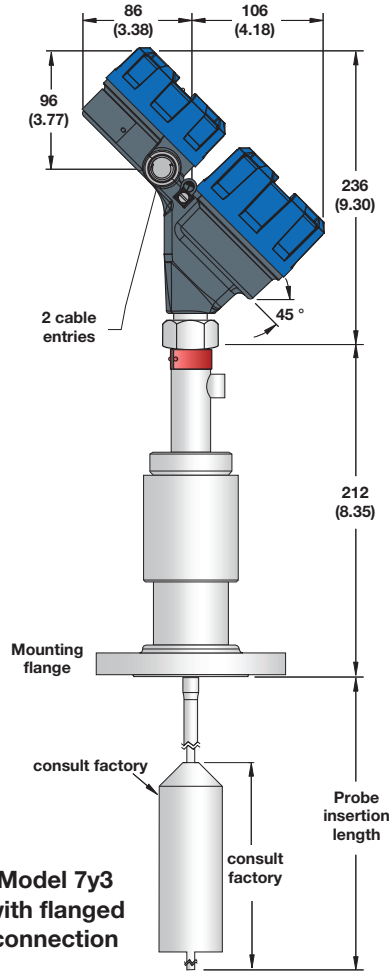

**Model 7y3
with flanged connection**

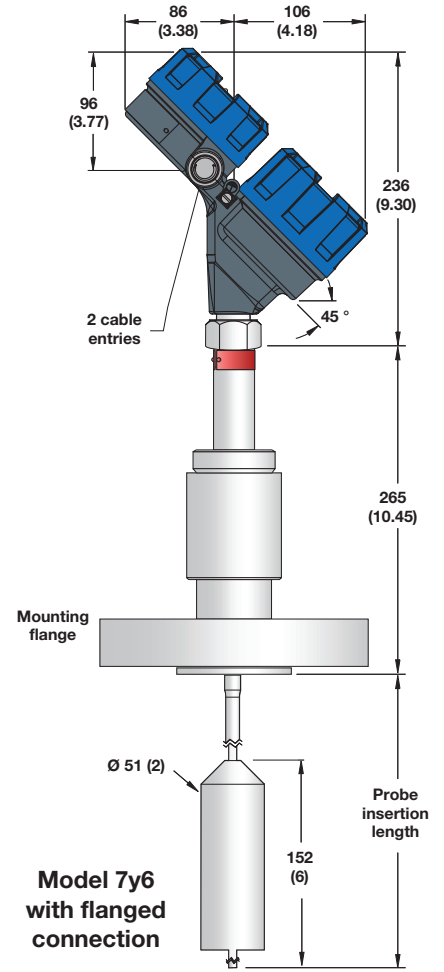

**Model 7y6
with flanged connection**

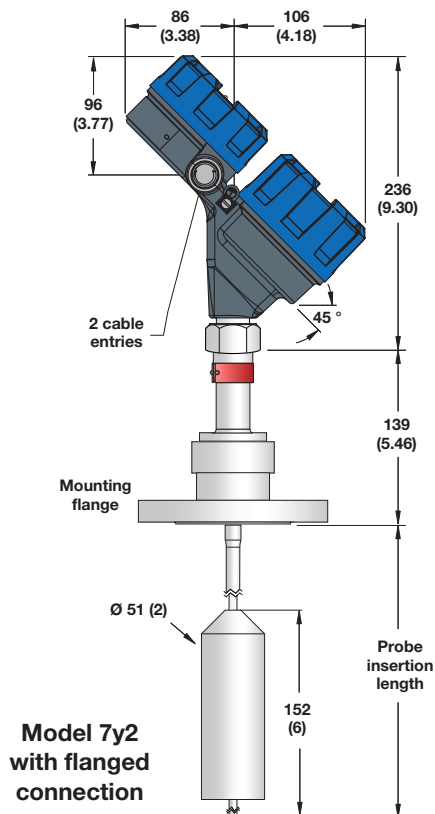

**Model 7y2
with flanged connection**

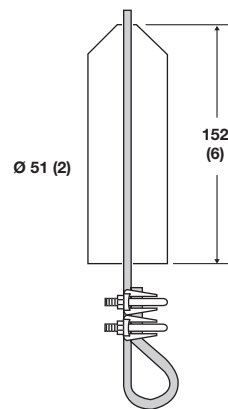

**7y2: SST weight
2,25 kg (5 lbs.)**

"IN TANK" STANDARD SINGLE ROD PROBE MOUNTING CONSIDERATIONS

For Rigid Models 7yF, M, N and Flexible Models 7y1, 2 and 6

1. Turbulence

The bottom of rigid probes should be stabilized if turbulence will cause a deflection of more than 75 mm (3") at the end of a 3 m (10') length. The probe should not make contact with metal.

2. Nozzle

Single rod performance in nozzles can be improved by ensuring the following:

- Nozzle must be 50 mm (2") or larger diameter.
- Nozzle should be as short as possible.
- Nozzle inside diameter (A) should be \geq to nozzle height (B).
 - If this is not the case, adjustments to BLOCKING DISTANCE and/or SENSITIVITY parameters may be required.

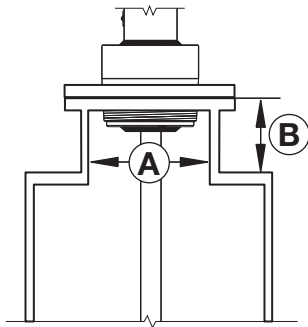

Correct Installation

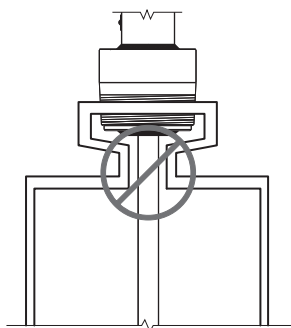

Pipe reducers should not be used

3. Metallic (conductive) obstructions in tank.

Although it depends on the transmitter configuration, objects in the proximity of the probe can cause erroneous readings. Please refer to the table below for guidelines, but please contact the factory with any questions as the distances shown can be reduced with the use of PACTware™.

Distance to probe	Acceptable objects
< 150 mm (6")	Continuous, smooth, parallel, conductive surface (e.g. metal tank wall); probe should not touch tank wall
> 150 mm (6")	< 1"/DN25 diameter pipe and beams, ladder rungs
> 300 mm (12")	< 3"/DN80 diameter pipe and beams, concrete walls
> 450 mm (18")	All remaining objects

Note: A metal stillwell/cage of max. 6"/DN150 size or a metal tank wall parallel to the probe within 150 mm (6") will allow the unit to operate accurately in media with dielectrics down to ϵ_r 1.4.

4. Non-metallic vessels

A metal flange is highly recommended for optimum performance in plastic vessels.

NOTE: Single rod probes must be used in metallic vessels or stillwell to maintain CE noise immunity.

Shutdown /Overfill protection

Special consideration is necessary in any shutdown/overfill protection application where single rod GWR probes are used. To ensure proper measurement, use Overfill Capable single rod probes, such as the Model 7yG, L, or J Caged probes in the appropriate cage/chamber/stillwell.

Mounting Considerations for Single Flexible probes measuring Bulk Solids

The Model 7y2 Bulk Solid probe is designed for a 1360 kg (3000 lb.) pull-down force for use in applications such as sand, plastic pellets, and grains.

- To reduce excessive stresses on the top of the vessel, do not secure the metal probe weight to the bottom of the vessel.
- Mount the probe at least 300 mm (12") from the wall. The ideal location is 1/4 to 1/2 the diameter to average the angle of repose.

The Orion Instruments® Aurora® is the patented combination of the ECLIPSE Guided Wave Radar transmitter and a Magnetic Level Indicator (MLI). The integration of these two independent technologies provides excellent redundancy. A custom float positioned within the AURORA chamber travels up and down following level changes. The float contains an internal group of magnets that are “coupled” with magnets in the flags of the visual indicator mounted on the outside of the chamber. As the float moves, the flags rotate to expose the color of their opposite side. The position where the flag’s color changes corresponds to a point on the measuring scale indicating true level. In addition to this external visual indicator operated by the AURORA internal float, the ECLIPSE

Model 706 transmitter reflects electromagnetic radar pulses directly off the liquid surface providing a real-time continuous level output.

Refer to the Magnetrol® Sales Bulletin BE 57-138 for details and additional options on AURORA chambers.

Regardless of whether a standard chamber or AURORA chamber is being used it is important to remember:

- Ensure that the Model 706 probe extends at least 100 mm (4") past the lower process connection of the chamber
- Utilize Overfill-capable probes for optimal GWR performance.

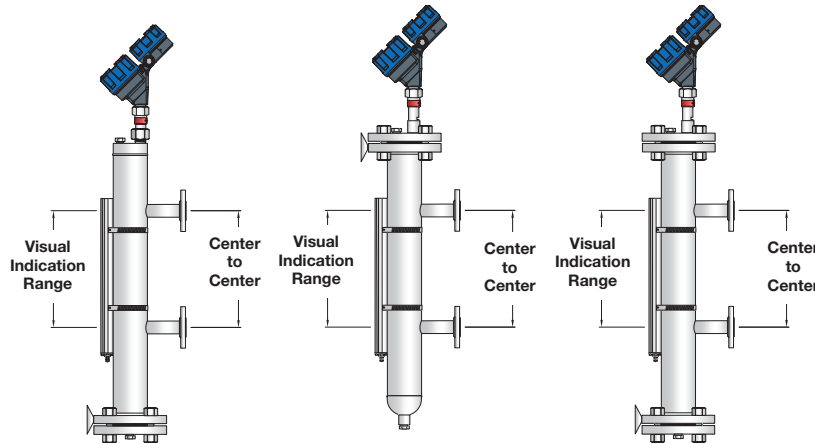

QUALITY ASSURANCE - ISO 9001

THE QUALITY ASSURANCE SYSTEM IN PLACE AT MAGNETROL GUARANTEES THE HIGHEST LEVEL OF QUALITY DURING THE DESIGN, THE CONSTRUCTION AND THE SERVICE OF CONTROLS. OUR QUALITY ASSURANCE SYSTEM IS APPROVED AND CERTIFIED TO ISO 9001 AND OUR TOTAL COMPANY IS COMMITTED TO PROVIDING FULL CUSTOMER SATISFACTION BOTH IN QUALITY PRODUCTS AND QUALITY SERVICE.

PRODUCT WARRANTY

ALL MAGNETROL ELECTRONIC AND ULTRASONIC LEVEL CONTROLS ARE WARRANTED FREE OF DEFECTS IN MATERIALS AND WORKMANSHIP FOR 18 MONTHS FROM THE DATE OF ORIGINAL FACTORY SHIPMENT. IF RETURNED WITHIN THE WARRANTY PERIOD; AND, UPON FACTORY INSPECTION OF THE CONTROL, THE CAUSE OF THE CLAIM IS DETERMINED TO BE COVERED UNDER THE WARRANTY; THEN, MAGNETROL INTERNATIONAL WILL REPAIR OR REPLACE THE CONTROL AT NO COST TO THE PURCHASER (OR OWNER) OTHER THAN TRANSPORTATION. MAGNETROL SHALL NOT BE LIABLE FOR MISAPPLICATION, LABOR CLAIMS, DIRECT OR CONSEQUENTIAL DAMAGE OR EXPENSE ARISING FROM THE INSTALLATION OR USE OF THE EQUIPMENT. THERE ARE NO OTHER WARRANTIES EXPRESSED OR IMPLIED, EXCEPT, SPECIAL WRITTEN WARRANTIES COVERING SOME MAGNETROL PRODUCTS.

BULLETIN: BE 57-106.10
EFFECTIVE: AUGUST 2021
SUPERSEDES: November 2019

UNDER RESERVE OF MODIFICATIONS



MAGNETROL®

AMETEK®
SENSORS, TEST & CALIBRATION