

GENERAL CHARACTERISTICS

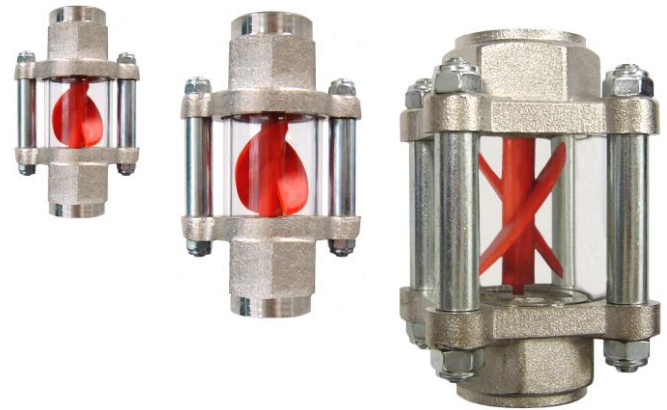

The indicators of flow of FD series allow a visual inspection of the passage of liquids in hydraulic systems. The propeller is coloured for better visualization with opaque liquids. The indicator is equipped with a viewer pipe in natural glass.



- Rugged construction.
- Bidirectional operation.
- Viewer pipe made in high resistance glass.
- Easy to install.

TECHNICAL DATA

Tab.1

Ø	DN Code	Q max. l/min	Q min. to start the rotor H ₂ O	I/min 40 cSt	I/min 41-150 cSt	ΔP max Bar	P max Bar	T max °C	Weight Kg	Dimensions mm			
										A	B	C	SW
1/4"	008	6	0,8	3	4	0,25	30	90	0,2	66	22	37	17
3/8"	010	10	1,4	3,5	4,5	0,25	30	90	0,4	94	31	58	27
1/2"	015	15	1,4	3,5	4,5	0,25	30	90	0,4	94	31	58	27
3/4"	020	30	2,5	4	5,5	0,25	30	90	1	105	47	67	42
1"	025	50	2,5	4	5,5	0,25	30	90	1	105	47	67	42

See Tab.3

Thread Ø UNI 228/1

MATERIALS

Tab.2

Description	Code BFG
Body	Nickel plated brass
Rotor	Red PA66
Axes of rotation	PA66
Viewer pipe	Pyrex glass
Gasket	NBR

DIMENSIONS

Tab.3

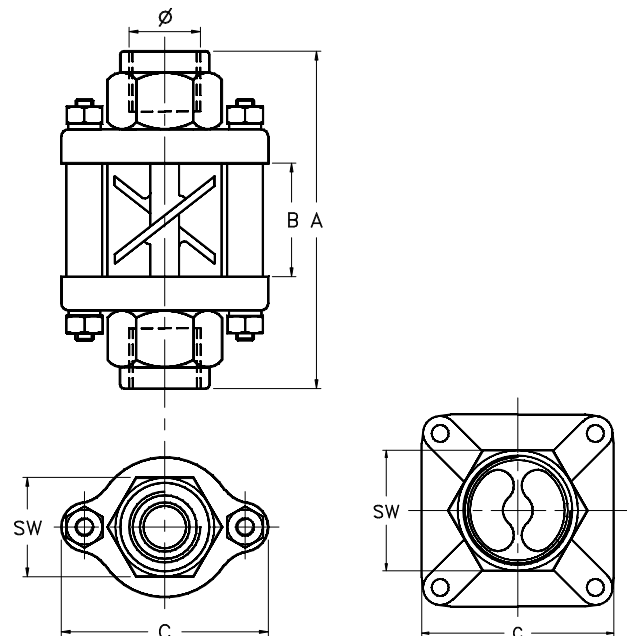

INSTALLATION

The mounting can take place in any position, with the only precaution to avoid the connection with rigid pipes if not in perfect alignment with the instrument.

NOMENCLATURE

FD	025	BFG
•		
	•	
		•

Name - Type

Tab.1 Process connection dimensions

Tab.2 Material