

Flow Indicator WR1-...GM / K

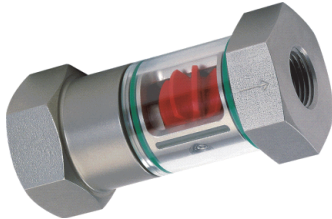

- Internal wiper provides ability to clean the glass without removing the device.
- Sliding bearing made from PEEK for liquids, or grease-free ball bearing for air and gases
- Rotor visible from 360°

Characteristics

Mechanical flow indicator, for fluid media, with rotor for quantitative flow display. The rotor turns in proportion to the flow. Robust construction in brass or stainless steel.

Technical data

Nominal width	DN 8..40	
Process connection	female thread G 1/4..G 1 1/2	
Display range	0.7..700 l/min	for details see table "Ranges"
Q_{max.}	to 700 l/min	
Pressure resistance	PN 16 bar	
Medium temperature	0..+100 °C	
Ambient temperature	0..+70 °C	
Materials medium-contact	<i>Brass construction:</i> CW614N nickelled, borosilicate glass, NBR	<i>Stainless steel construction:</i> 1.4305, borosilicate glass, FKM
	DN 8..25: POM red DN 32..40: Nylon white for fluids: PEEK for gases: Steel 100 CR 6 chrome coated	
Medium	water, gases (oils have a tendency to a higher running-up value)	
Weight	see table "Dimensions and weights"	
Installation location	as desired, except for inwards flow from above	

Ranges

Fluids

G	Start-up quantity for rotor, l/min			Q _{max.} recommended	Types
	H ₂ O	40 mm ² /s	41..150 mm ² /s		
G 1/4	0.7	1.5	2.7	4	WR1-008G.W
G 3/8	0.8		2.8	8	WR1-010G.W
G 1/2	1.4	1.8	3.2	12	WR1-015G.W
G 3/4		2.7	5.9	25	WR1-020G.W
G 1	1.7	3.0	7.0	40	WR1-025G.W
G 1 1/4	8.0	5.9	7.9	80	WR1-032G.W
G 1 1/2		7.3		100	WR1-040G.W

Special ranges are available.

Air / gases

G	Running-up amount for rotor l/min 1 bar abs 20 °C	Q _{max.} recommended	Types
G 1/4	18	60	WR1-008G.G
G 3/8	20	150	WR1-010G.G
G 1/2	25	250	WR1-015G.G
G 3/4	25	250	WR1-020G.G
G 1	35	350	WR1-025G.G
G 1 1/4	60	600	WR1-032G.G
G 1 1/2	70	700	WR1-040G.G

Special ranges are available.

Dimensions and weights

G	Types	L	SW	X	Weight kg
G 1/4	WR1-008G.	71	36	9	0.35
G 3/8	WR1-010G.				
G 1/2	WR1-015G.	86	46	13	0.65
G 3/4	WR1-020G.				
G 1	WR1-025G.	104	65	19	1.60
G 1 1/4	WR1-032G.	120			
G 1 1/2	WR1-040G.	130			

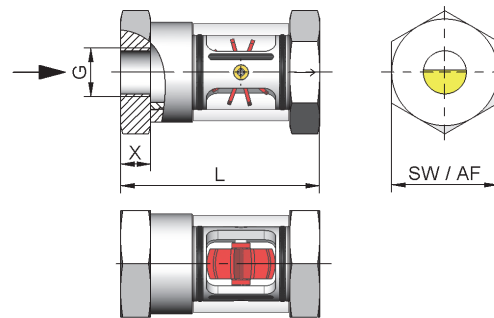

Ordering code

WR1 - 1. 2. 3. 4. **G**

1. Nominal width	
008	DN 8 - G 1/4
010	DN 10 - G 3/8
015	DN 15 - G 1/2
020	DN 20 - G 3/4
025	DN 25 - G 1
032	DN 32 - G 1 1/4
040	DN 40 - G 1 1/2
2. Process connection	
G	female thread
3. Connection material	
M	brass
K	stainless steel
4. For medium	
W	liquids
G	air and gaseous media

Options

- smaller start-up quantities / special diaphragm
- Wiper seal made from EPDM