



ADVANCED FLUID MANAGEMENT SOLUTIONS

An overview of the RAASM world



RAASM



**HENNLICH
ŽIJEME TECHNIKOU**

o.z. HENNLICH CEMA-TECH,
Dolní 183/30, 591 01 Žďár nad Sázavou

Telefon: +420 566 630 524
E-mail: cema-tech@hennlich.cz

www.hennlich.cz/cema-tech



founded in 1975



*the human side
of Quality*



**HENNLICH
ŽIJEME TECHNIKOU**

o.z. HENNLICH CEMA-TECH,
Dolní 183/30, 591 01 Žďár nad Sázavou

Telefon: +420 566 630 524
E-mail: cema-tech@hennlich.cz

www.hennlich.cz/cema-tech

STUDY, RESEARCH AND DESIGN

The real strength of a firm starts with the ability of its study and research departments to always find the most suitable solutions to address market demands.

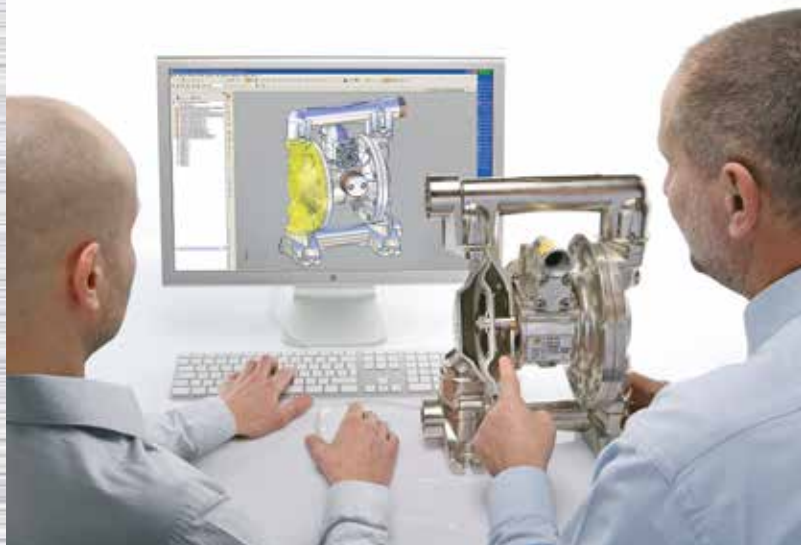

TESTING AND INSPECTIONS

A sophisticated test room enables careful testing of the quality of new products before they are put on the market.

ASSEMBLY LINES

Dedicated equipment specially designed to facilitate assembly operations, at the same time allowing an effective and automatic control of quality.



STORAGE OF COMPONENTS

Our vertical stores enable quick and careful preparation of the components and spare parts intended for assembly and sale.



TECHNOLOGY
INNOVATION
QUALITY
SAFETY
RELIABILITY



TECHNICAL ASSISTANCE

The aim is to always respond fully to the questions of our customers and meet all their needs.



HENNLICH
ŽIJEME TECHNIKOU

o.z. HENNLICH CEMA-TECH,
Dolní 183/30, 591 01 Žďár nad Sázavou

Telefon: +420 566 630 524
E-mail: cema-tech@hennlich.cz

www.hennlich.cz/cema-tech

BRAKE BLEEDERS, TYRE INFLATORS, WASH AND DEPLETED OIL COLLECTION

BRAKE BLEEDERS



With 2 or 3 chambers 5 l



Automatic filling 13 l



With inflation gun 13 - 24 l

PORTABLE INFLATORS



With brush or by dipping 65 l

WASHING TANKS AND NON-TOXIC SPRAYERS



AISI 304 st. steel 24 l



Painted steel 16 - 24 l

PIT OR FLOOR DRAINERS



Adjustable trolley 65 - 110 - 150 l



With or without exchange pump 50 - 95 - 150 l



DEPLETED OIL DRAINERS



Central or side sump 65 - 90 - 115 l



With or without prechamber 65 - 90 - 115 l



With pantograph 65 - 115 l



Wall mounted pneumatic kit

OIL AND GREASE DISPENSING

HAND-OPERATED PUMPS - PNEUMATIC DISPENSERS GREASERS 13 kg



Double-acting manual pump 16 - 24 l

Air-operated 8-10 bar 16 - 24 l

With lever or pedal 400 bar 13 kg

High pressure 350 bar transfer 20 bar

AIR-OPERATED OIL AND GREASE PUMPS

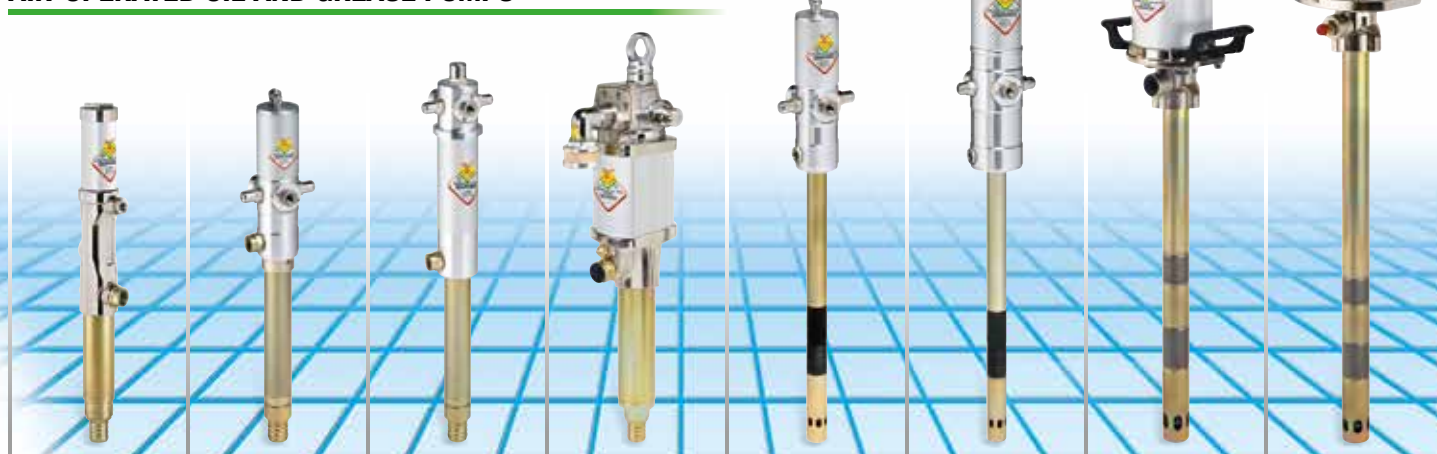

Series 500
R 1:1-35 l/min
Viton® seals

Series 600
R 3:1-14 l/min
NBR seals

Series 650
R 5:1-18 l/min
NBR seals

Series 900
R 5:1-45 l/min
PU seals

Series 600
R 50:1-1500 g/min
PU seals

Series 700
R 65:1-1900 g/min
PU seals

Series 900
R 45:1-4400 g/min
PU seals

Series 1500
R 70:1-7000 g/min
PU seals

OIL AND GREASE DISPENSING KITS



Movable platforms for oil dispensing with pump R 3:1 - 5:1 litre-counter gun and hose reel



Oil dispensing kits for 20 - 220 l drums with pump R 3:1 - 5:1 and litre-counter gun



Movable greasing kits for drums 20 - 200 kg R 50:1 - 1500 g/min



Wall-mounted dispensing kits with pump R 3:1 - 5:1 and hose reel

DISPENSER GUNS, LITRE COUNTERS, PULSERS, SERVICE COLUMNS, FLUID CONTROL SYSTEM

DISPENSER GUNS



S. 1/2" for oil.
Delivery 40 l/min



S. 1/2" for oil.
Delivery 65 l/min



S. 3/4" for oil.
Delivery 70 - 85 l/min



S. 1/2" for antifreeze
and windshield washing
liquid. Delivery 40 l/min



DIGITAL LITRE COUNTERS AND PULSER FOR OIL, DIESEL FUEL, ANTIFREEZE AND WINDSHIELD FLUID



Series 1/2"
Delivery 35-40 l/min

Series 3/4"
Delivery 70-90 l/min

Series 1"
Delivery 100-120 l/min

FLUID CONTROL SYSTEM

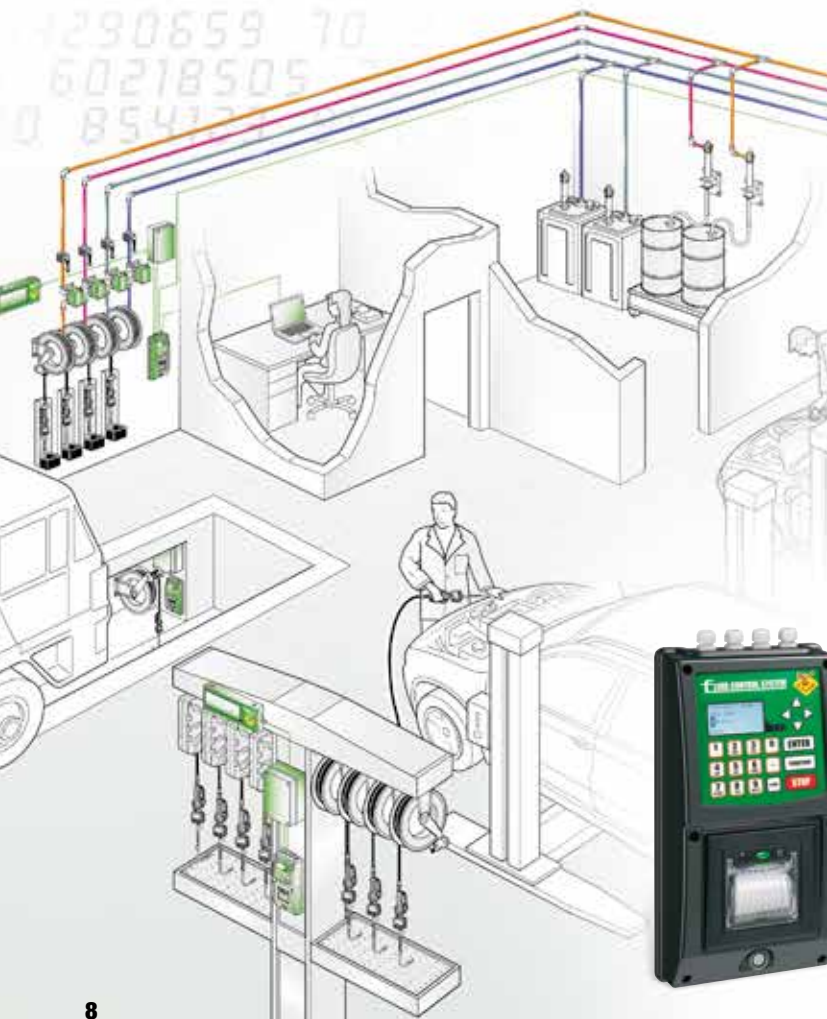

Operator control
unit (OCU)

Service
columns

INDUSTRIAL AND DIAPHRAGM PUMPS, RAM HOISTS

DIAPHRAGM PUMPS IN ALUMINIUM R 1:1



In accordance with directive ATEX



Series 120-AB
1/2" - 70 l/min



Series 1000-AB
1" - 170 l/min



Series 1140-AB
1.1/4" - 200 l/min



Series 1120-AB
1.1/2" - 480 l/min



Series 2000-AB
2" - 560-610 l/min

AVAILABLE DIAPHRAGMS

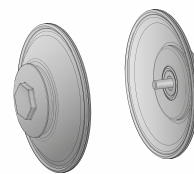

- > NBR HIGH NITRIL
- > HYTREL®
- > EPDM
- > SANTOPRENE™
- > PTFE + HYTREL®

POLYPROPYLENE DIAPHRAGM PUMPS - MOTOR IN ALUMINIUM R 1:1



Series 120-PB
1/2" - 60 l/min



Series 120-PB
1/2" - 60 l/min
double inlet



Series 1000-PB
1" - 170 l/min



Series 1000-PB
1" - 170 l/min
double inlet



In accordance with directive ATEX

POLYPROPYLENE DIAPHRAGM PUMPS - MOTOR IN POLYPROP. R 1:1



Series 120-PPB
1/2" - 60 l/min



Series 120-PPB
1/2" - 60 l/min
double inlet



Series 1000-PPB
1" - 170 l/min



Series 1000-PPB
1" - 170 l/min
double inlet

INDUSTRIAL AIR-OPERATED PUMPS OIL, GREASE AND INDUSTRIAL FLUIDS



In accordance with directive ATEX



Oil and industrial fluids
S. 900 R. 2:1 ÷ 11:1
30 ÷ 95 l/min
Grease R. 45:1 ÷ 70:1
3 ÷ 4,4 kg/min



Oil and industrial fluids
S. 1200 R. 3:1 ÷ 18:1
23 ÷ 100 l/min
Grease R. 40:1 ÷ 75:1
4,4 ÷ 10 kg/min



Industrial fluids
S. 1800 R. 5:1 ÷ 8:1
65 ÷ 90 l/min



Oil and industrial fluids
S. 1500 R. 4:1 ÷ 6:1
80 ÷ 110 l/min
Grease R. 70:1
7 kg/min



Ram hoists

HOSE REELS FOR FLUID AND CABLE REELS

WHEN CHOOSING A HOSE REEL IT IS IMPORTANT TO CONSIDER:

- type of fluid to be dispensed
- delivery in l/min to be dispensed
- length and width of the hose to be used
- pressure of the fluid

Air-Water 20/400 bar
Oil and allied products 150 bar
Grease 400 bar
Diesel fuel 10 bar
AdBlue® 10 bar
Oil-Water 200 bar
Oil-Paints 200 bar
Welding 20 bar
LPG-methane 20 bar

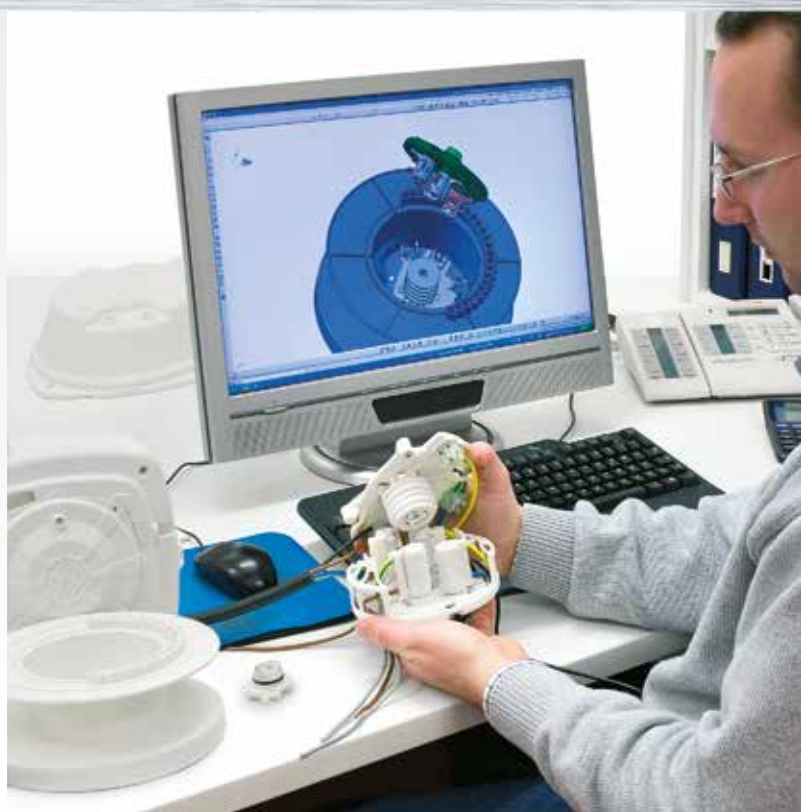

You can choose some hose reels versions with different colours besides the standard one	RAL 7035 	RAL 1004 	RAL 3020 	RAL 5002 	RAL 9005
	POLYURETHANE 	BLACK SYNTHETIC RUBBER 	HYGIENIC HOSE 	RUBBER SBR/EPDM ISO 3821 	RUBBER NBS/PVC ISO 3821
RANGE OF HOSES					

CABLE REELS

Advantages

- Electric collector designed for better performances also with high currents.
- Thermal protector against overheating of the rewinded cable mounted in all the models.
- IP44 protection degree provided for all the electrical parts.
- Spring tested for more than 10 working years with the possibility to easily adjust the rewinding force.
- Cable guide with rollers equipped with 4 rollers in each model designed to save the work life of the cable.
- Different options for different needs: rewinding clutch, bayonet bracket and protection cap.



FIXED AND ADJUSTABLE INDUSTRIAL SERIES IN PAINTED STEEL AND AISI 304 - AISI 316 STAINLESS STEEL

Supplied with hose in black synthetic rubber or hygienic blue rubber



 In accordance with directive ATEX

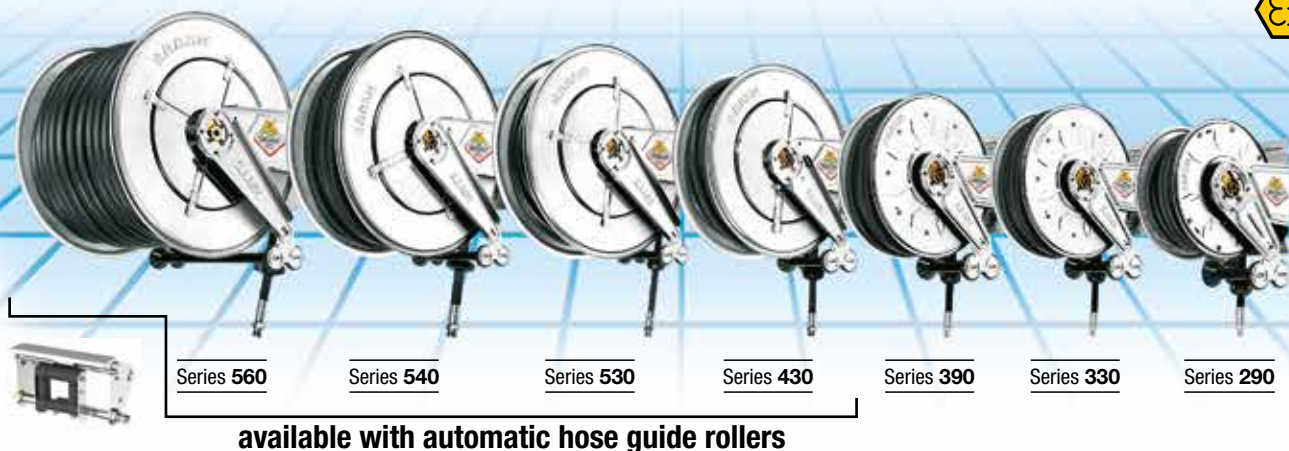

STANDARD SERIES WITH ENCLOSURE IN TECHNOPOLYMER, PAINTED STEEL OR AISI 304 STAINLESS STEEL

Supplied with polyurethane hose



STANDARD SERIES IN PAINTED STEEL

Supplied with polyurethane hose



HOSE CHARACTERISTICS

- ✓ Polyurethane hose (blue) with protection spring on fittings.
- ✓ Brass swivel joint pipe outbound.
- ✓ Brass fittings.
- ✓ Length in entrance 1,5 m.

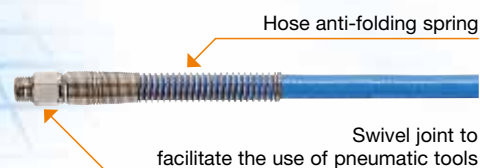

INDUSTRIAL SERIES WITH DRUM IN SHOCKPROOF ABS, OPEN OR ENCLOSED VERSION

With supporting structure in painted steel or AISI 304 stainless steel

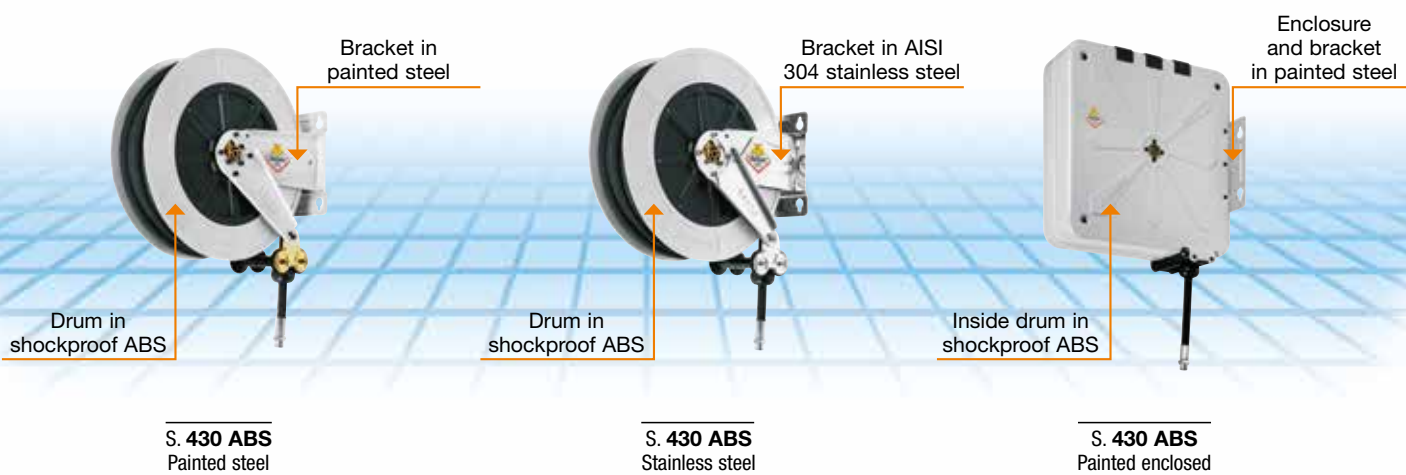

INDUSTRIAL SERIES FOR SPECIFIC APPLICATIONS



In accordance with directive ATEX

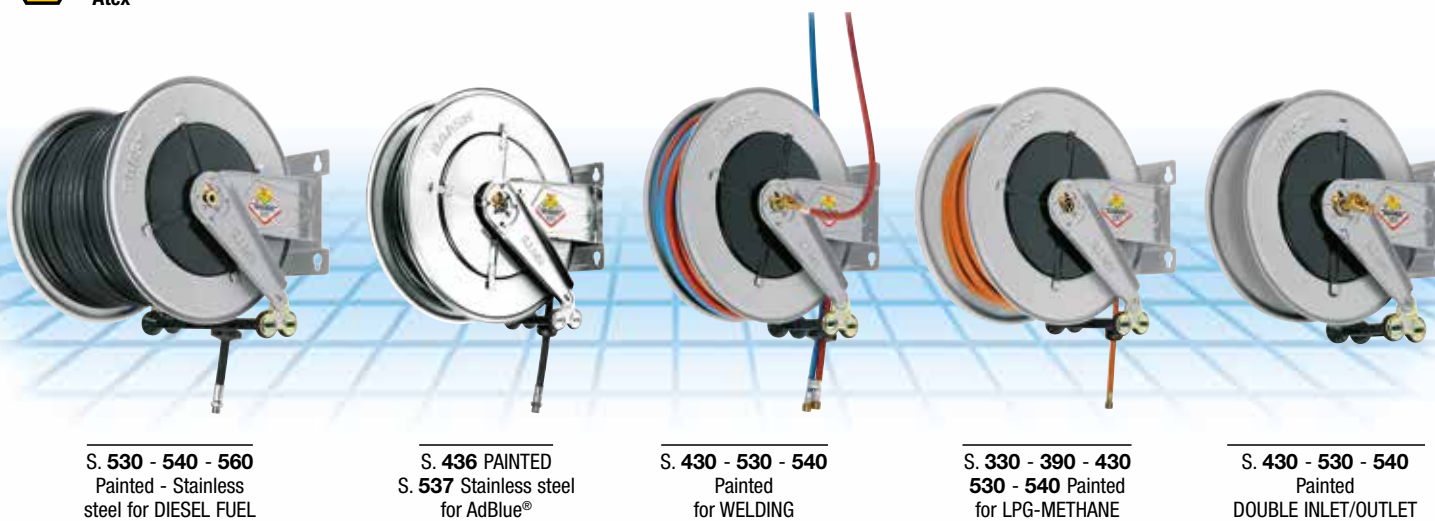

MANUAL SERIES WITH SECURITY SYSTEM

In painted steel or stainless steel AISI 304 - 316



In accordance with directive ATEX



SECURITY SYSTEM

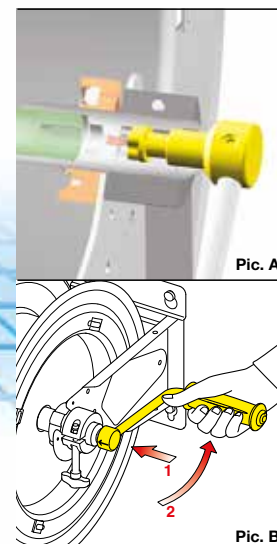

The hose reel is designed with a **new security system** that allows the handle to stay in place, avoiding the rotation during the manual hose unreeling (Picture A - B).

SERIES 500 HOSE REELS IN PAINTED STEEL

With security system



Width 240 - 320 - 460 - 600 mm

TROLLEY MOUNTED HOSE REELS

In painted steel or stainless steel AISI 304 - 316



Manual s. 530 - 540 - 560

SERIES 600 MOTORIZED HOSE REELS IN PAINTED STEEL

Available with hydraulic or pneumatic motor with 1" or 1.1/2" passage



Series 617 - 637 Hydraulic
width 220 - 400 mm



Series 618 - 638 Pneumatic
width 220 - 400 mm

SERIES 700 MANUAL AND MOTORIZED HOSE REELS IN PAINTED STEEL

Available with various motorizations with 2" passage



Manual

Electric 230V

MANUAL	ELECTRIC 24V
HYDRAULIC	PNEUMATIC

CABLE REELS SERIES 280 - ENCLOSED HOSE REELS SERIES 280 Air-Water



S. 280
400 V Three phase
without socket

S. 280
230 V Single phase with socket
and Schuko plug

S. 280
Air-Water
20 bar / 40 °C

REWINDING CLUTCH



"SPEED CONTROL"

PROTECTION CAP

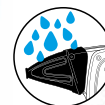

BAYONET BRACKET



SWIVELLING HOOK



PROTECTED SWITCH



CABLE REELS SERIES 280 - 290 with lamp



S. 280
Without transformer
fluorescent portable lamp and led

S. 290
With transformer 230 V
led portable lamp

S. F230 - F12 - F24
Fluorescent lamp
S. L1224
Led lamp

GROUNDING CABLE REEL - Enclosed cable reel SERIES 280 - Cable reel SERIES 350



Ex In accordance
with directive
Atex

EXAMPLE OF OPERATION

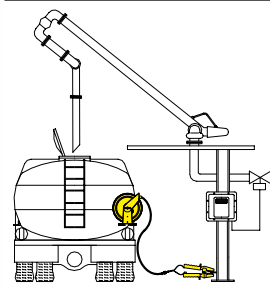
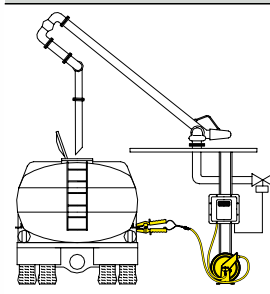

EARTHING PLIERS 100A



EARTHING PLIERS 50A



ANTI-DEFLAGRATION EARTHING PLIERS 10A



RAASM products
are present worldwide through a network of
qualified dealers.



www.raasm.com



**HENNLICH
ŽIJEME TECHNIKOU**

o.z. HENNLICH CEMA-TECH,
Dolní 183/30, 591 01 Žďár nad Sázavou

Telefon: +420 566 630 524
E-mail: cema-tech@hennlich.cz

www.hennlich.cz/cema-tech

IDEAL FOR THE FOLLOWING **SECTORS**

- **AUTOMOTIVE**
- **MECHANICAL INDUSTRY**
- **CHEMICAL INDUSTRY**
- **TANNING INDUSTRY**
- **WOOD INDUSTRY**
- **MARBLE INDUSTRY**
- **MANUFACTURING INDUSTRY**
- **MINING SECTOR**
- **AGRICULTURE**
- **BUILDING**
- **ROAD WORKS**
- **BOATING**
- **AVIATION**
- **CIVILIAN AND MILITARY AIRPORTS**
- **RAILWAY SECTOR**



Authorized dealer



Company with an ISO 9001:2015 certified quality management system

RAASM S.p.A.
36022 S. ZENO DI CASSOLA (VI) - Via Marangoni, 33 - ITALY

Export department
Tel. +39 0424 571130 - Fax +39 0424 571135

Technical department
Tel. +39 0424 571150 - Fax +39 0424 571155
info@raasm.com - www.raasm.com



All rights reserved to Raasm S.p.A.



**HENNLICH
ŽIJEME TECHNIKOU**

o.z. **HENNLICH CEMA-TECH**,
Dolní 183/30, 591 01 Žďár nad Sázavou

Telefon: +420 566 630 524
E-mail: cema-tech@hennlich.cz

www.hennlich.cz/cema-tech