

JX2

Ø 6 ÷ 25 mm - Slide Table Actuator

- Slide table actuator with integrated cross rollers and pneumatic cylinder
- Suitable for precision assembly by means of tolerance centering holes
- High positioning repeatability of the piece
- Version with stroke adjustment screw on both sides
- Version with hydraulic shock absorbers on both sides

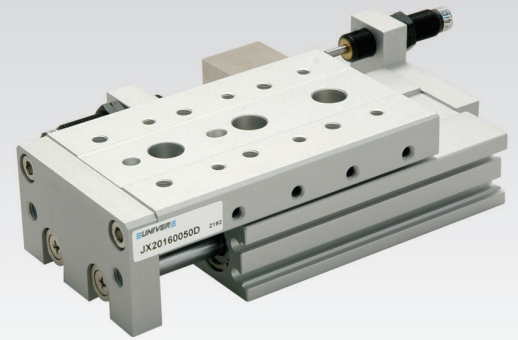

TECHNICAL CHARACTERISTICS

Ambient temperature	-10 ÷ 60 °C
Fluid	filtered air, with or without lubrication
Working pressure	1 ÷ 7 bar
Piston speed	50 ÷ 500 mm/s
Bores	Ø 6 - 8 - 12 - 16 - 20 - 25 mm
Cushionings	elastic buffers

CONSTRUCTIVE CHARACTERISTICS

Body	aluminium
Piston	aluminium
Piston rod	stainless steel
Piston seals	nitrile rubber
Table	aluminium
Front plate	aluminium
Linear guide	carbon steel
Shock absorber seals	nitrile rubber in both sides
Magnet	standard supplied

CODIFICATION KEY

J	X	2	0	2	0	1	5	0	
1		2				3			4

1 Series	2 Bore (mm)	3 Stroke (mm)	4 Version
JX2 = Ø6 ÷ 25 mm - Slide Table Actuator	006 = Ø6 008 = Ø8 012 = Ø12 016 = Ø16 020 = Ø20 025 = Ø25	010 = 10 075 = 75 020 = 20 100 = 100 030 = 30 125 = 125 040 = 40 150 = 150 050 = 50	D = Stroke adjusting screw (0 ÷ 5 mm each side) R = Hydraulic shock absorbers (Ø8 ÷ 25 mm)

Strokes (mm)	
Ø	10 20 30 40 50 75 100 125 150
6	10 20 30 40 50
8	10 20 30 40 50 75
12	10 20 30 40 50 75 100
16	10 20 30 40 50 75 100 125
20	10 20 30 40 50 75 100 125 150
25	10 20 30 40 50 75 100 125 150

Magnetic sensor DF-T series, see chapter 5 accessories.

Subject to change

Fixing schemes

Top fixing

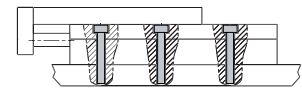

Bottom fixing

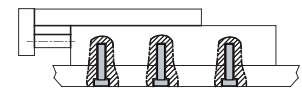

Vertical fixing

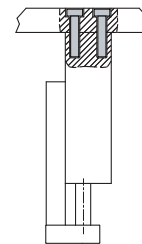

Theoretical forces (N)

Cylinder Ø	Working surface area (mm ²)		Working pressure (bar)											
	Thrust	Traction	Thrust						Traction					
			2	3	4	5	6	7	2	3	4	5	6	7
6	57	42	10	15	20	25	30	40	8	12	16	20	24	28
8	100	75	20	30	40	50	60	70	14	21	28	35	42	53
12	220	170	44	66	88	110	132	154	34	51	68	85	102	119
16	400	300	80	120	160	200	240	280	60	90	120	150	180	210
20	620	470	124	186	248	310	372	434	94	141	188	235	282	329
25	980	750	196	294	392	490	585	686	150	225	300	375	450	525

Cylinder mass (standard version)

Cylinder Ø	Mass (g)								
	Strokes (mm)								
	10	20	30	40	50	75	100	125	150
6	80	100	115	155	180	-	-	-	-
8	150	160	190	235	285	410	-	-	-
12	325	325	325	385	480	660	890	-	-
16	570	570	580	640	760	1100	1370	1700	-
20	960	980	1010	1100	250	1630	2150	2670	3200
25	1660	1680	1700	1840	2100	2650	3270	4140	4710

1 Max kinetic energy (Nm)

Cylinder Ø	Max absorb function	Shock absorbers
6	0,018	-
8	0,027	0,045
12	0,055	0,11
16	0,11	0,22
20	0,16	0,32
25	0,24	0,48

Maximum allowable load weight (Kg)

Cylinder Ø	Max load W
6	0,6
8	1
12	2
16	4
20	6
25	9

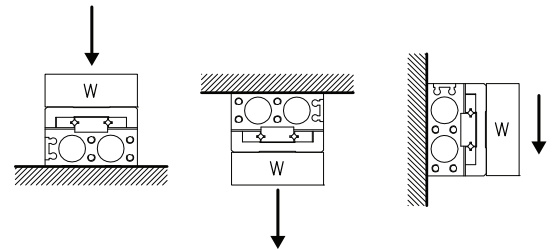

Motionless allowable torque (Nm) - Calculation method

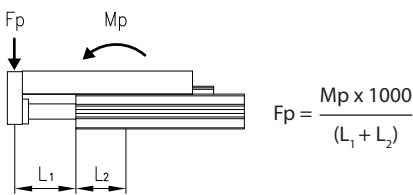

Mp = Bending moment

- L₁ Distance from the body to the point of load.
- L₂ Distance from the center of the body to his side.
- L₃ Distance from the center of the guide to the point of load.

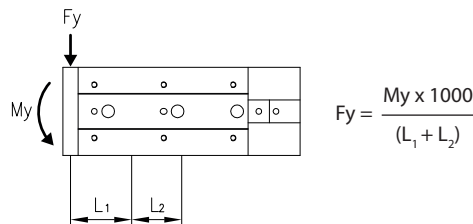

My = Bending moment

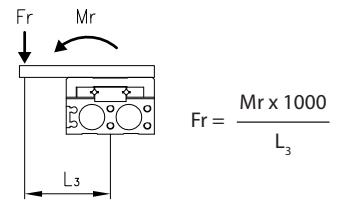

Mr = Torque

Cylinder Ø	Strokes (mm)								
	10	20	30	40	50	75	100	125	150
6	0,7	1	1,2	1,2	1,2	-	-	-	-
8	2	2	2,8	3,6	4,2	4,2	-	-	-
12	4,2	4,2	4,2	5,8	7	10	10	-	-
16	11,3	11,3	11,3	11,3	15,9	25	34,1	34,1	-
20	19,4	19,4	19,4	19,4	27,2	35	50,5	50,5	50,5
25	30,6	30,6	30,6	30,6	42,8	55,1	67,3	67,3	67,3

- Do not exceed load limit. Loads exceeding the limits may affect the slide precision
- Avoid impacts
- Inertial load must be within 1/10 of the allowable motionless load.

JX2

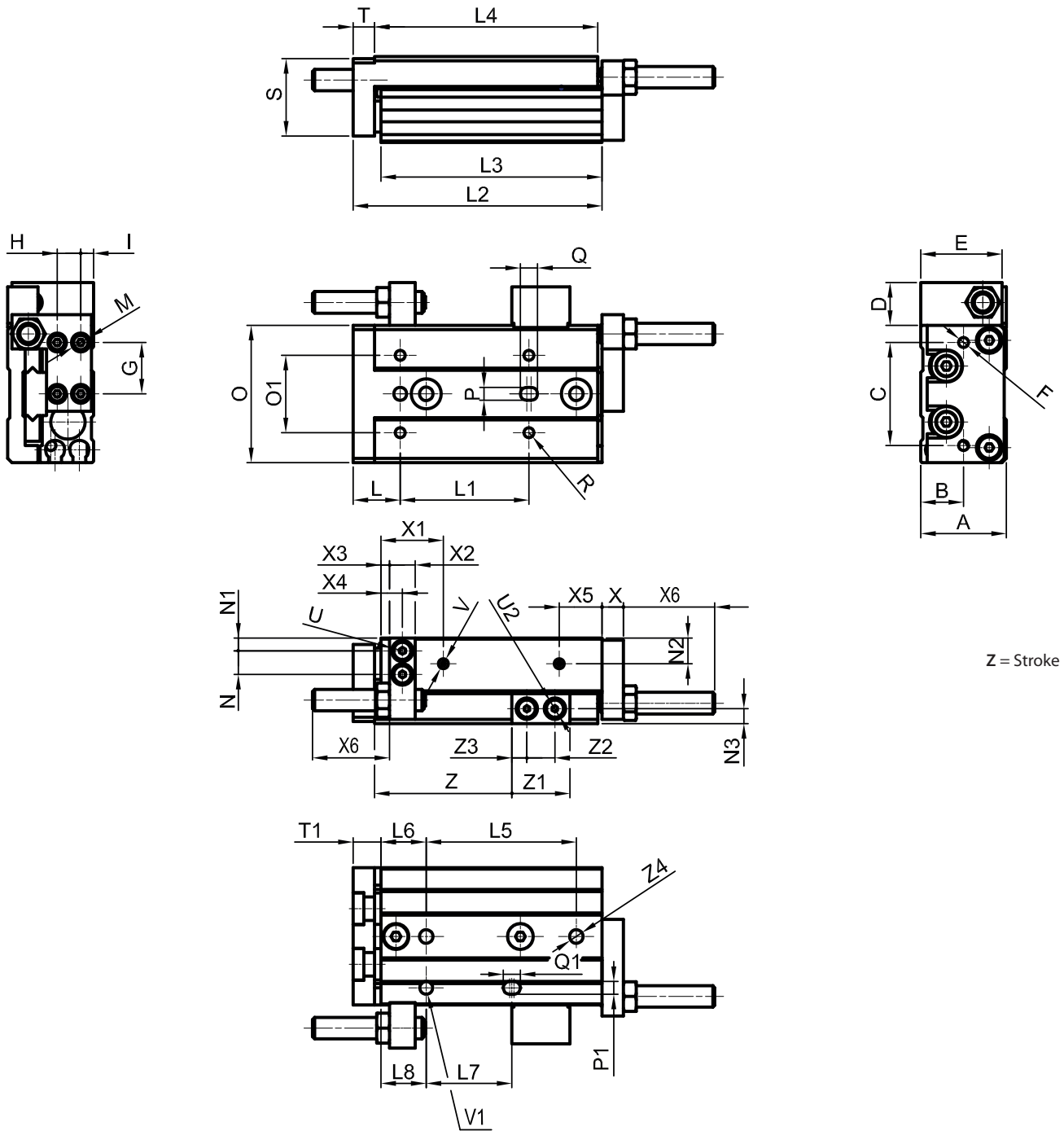

Z = Stroke

Part No.	A	B	C	D	E	F	G	H	I	L	L6	L8	M	N	N1	N2	N3	O	O1	P	P1
JX2006	20	10	24	10	18,5	M3x0,5x6	12	5,5	3	11	10,5	10,5	M2,5x0,4x3	5,5	3	6	3,5	32	18	3	3
JX2008	24	12	30	14,5	23,5	M4x0,7x6	15	6,5	3,5	12	11,5	11,5	M3x0,5x4	6,5	4	7	7	40	23	3	3
JX2012	32	15,5	38	15	31,5	M5x0,8x8	20	9	5	16	15	15	M4x0,7x6	10	5	10	8	50	28	4	4
JX2016	40	19,5	48	18	37,5	M6x1,0x10	26	12	6	21	19	19	M5x0,8x7	12	6	12	9,5	62	35	5	5
JX2020	50	25	58	24,5	47,5	M6x1,0x13	30	18	6	27	21,5	21,5	M5x0,8x6	14	8	15	14	76	46	5	5
JX2025	62	31	70	24,5	54,5	M8x1,25x15	38	22	7	30	23,5	23,5	M6x1,0x10	16	10	18	19	92	56	6	6

Part No.	Q	Q1	R	S	T	T1	U	U2	V	V1	X	X1
JX2006	4	4	M3x0,5x5	18	5	6,5	M2,5x0,45x3	M3x0,5x4	M3x0,5	Ø3x3	5	14,5
JX2008	4	4	M3x0,5x5	22	6	7,5	M3x0,5x4	M3x0,5x4	M5x0,8	Ø3x3	6	15
JX2012	5	5	M4x0,7x5	28,5	8	10	M4x0,7x6	M4x0,7Px6,5	M5x0,8	Ø4x3,5	8	19
JX2016	6	6	M5x0,8x8	36,5	10	12	M5x0,8x5,5	M5x0,8x5,5	M5x0,8	Ø5x4	10	24
JX2020	6	6	M5x0,8x10	45,5	13	15,5	M6x1,0x6,5	M6x1,0x6,5	G1/8	Ø5x5	12	27,5
JX2025	6	6	M6x1,0x13	55	15	17,5	M8x1,25x8,5	M8x1,25x8,5	G1/8	Ø6x6	15	30

Part No.	X2	X3	X4	X5	X6	Z1	Z2	Z3	Z4
JX2006	6	2	5	10	18	12,5	6,5	3	M4x0,7x8
JX2008	7	2	5,5	8,5	19	14,6	7	3,8	M4x0,7x8
JX2012	9,5	2	4,75	11	19	18,5	8,5	5	M5x0,8x10
JX2016	11	3	8,5	11	22	21	10	5,5	M6x1,0x12
JX2020	13	3	6,5	10	36	25	12	6,5	M6x1,0x12
JX2025	16	4	8	12	34	31	15	8	M8x1,25x16

Stroke	JX2006						
	L1	L2	L3	L4	L5	L7	Z
10	20	48	41,5	42	25	20	22,5
20	30	58	51,5	52	35	20	32,5
30	20	68	61,5	62	20	20	42,5
40	28	90	53,5	84	30	30	52,5
50	38	106	99,5	100	24	48	62,5

Stroke	JX2008						
	L1	L2	L3	L4	L5	L7	Z
10	25	56	48,5	49	28	20	23,5
20	25	61	53,5	54	30	30	33,5
30	40	72	64,5	65	20	20	43,5
40	50	90	82,5	83	28	28	53,5
50	38	108	100,5	101	23	50	63,5
75	50	158	150,5	151	28	56	88,5

Stroke	JX2012						
	L1	L2	L3	L4	L5	L7	Z
10	35	80	70	71	40	40	26,5
20	35	80	70	71	40	40	36,5
30	35	80	70	71	40	40	46,5
40	50	92	82	83	25	25	56,5
50	35	112	102	103	36	36	66,5
75	55	158	148	149	36	72	91,5
100	65	212	202	203	38	76	116,5

Stroke	JX2016						
	L1	L2	L3	L4	L5	L7	Z
10	35	87	75	76	40	40	29
20	35	87	75	76	40	40	39
30	35	87	75	76	40	40	49
40	50	97	85	86	50	50	59
50	35	112	100	101	30	30	69
75	55	162	150	151	35	70	94
100	65	210	198	199	35	70	119
125	70	260	248	249	35	70	144

Stroke	JX2008						
	L1	L2	L3	L4	L5	L7	Z
10	50	97	81,5	83	45	35	31
20	50	97	81,5	83	45	35	41
30	50	97	81,5	83	45	35	51
40	60	107	91,5	93	55	35	61
50	35	122	106,5	108	35	35	71
75	60	161	145,5	147	35	70	96
100	70	214	198,5	200	35	70	121
125	80	268	252,5	254	38	75,5	146
150	80	320	304,5	306	44	87,5	171

Stroke	JX2012						
	L1	L2	L3	L4	L5	L7	Z
10	50	108	90,5	92	45	45	35
20	50	108	90,5	92	45	45	45
30	50	108	90,5	92	45	45	55
40	60	118	100,5	102	55	55	65
50	35	131	113,5	115	35	35	75
75	60	172	154,5	156	35	70	100
100	70	213	195,5	197	35	70	125
125	75	271	253,5	255	38	76	150
150	80	311	293,5	295	44	80	175

1