



# easy triflex<sup>®</sup>

For simple multi-axis applications, easy filling from both sides



**easy triflex<sup>®</sup> advantages:**

- Easy filling with "easy" design
- Easy filling from both sides
- Easy to replace or combine with existing triflex<sup>®</sup> systems
- If square space is required



**When to use another 3D e-chain<sup>®</sup> series:**

- For complex robot applications
  - ▶ triflex<sup>®</sup> R - TRE, page 876
- For circular movements with high loads
  - ▶ twisterchain system, page 966

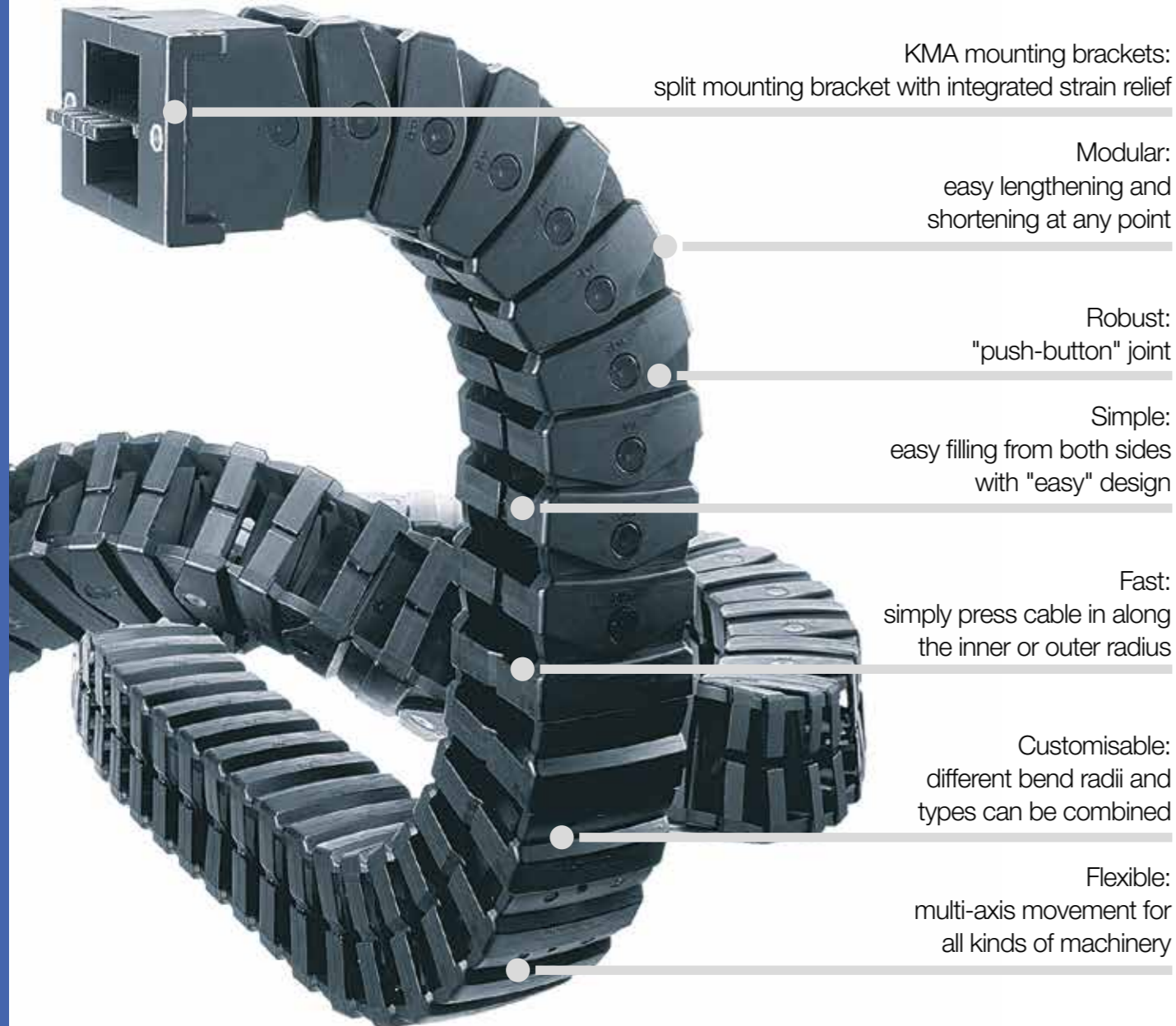

KMA mounting brackets:  
split mounting bracket with integrated strain relief

Modular:  
easy lengthening and shortening at any point

Robust:  
"push-button" joint

Simple:  
easy filling from both sides with "easy" design

Fast:  
simply press cable in along the inner or outer radius

Customisable:  
different bend radii and types can be combined

Flexible:  
multi-axis movement for all kinds of machinery

## For simple 3D applications, easy filling from both sides - easy triflex®

The easy triflex® series was developed to offer safe energy supply for multi-axis movements. In doing so the flexibility of a hose was combined with the stability and defined bend radius of an e-chain®. With easy triflex® the installation of cables and hoses is simple. With flexible crossbars the cables are simply pushed into the e-chain® from either side. The unique modular range allows very complex movements. For example it is possible to combine 1- 2- and 3-axis links in one e-chain®.

### Typical industries and applications

- Machine tools
- Robots
- Handling Equipment
- Material handling
- Plastics industry
- Construction machinery
- Vehicles production
- General mechanical engineering
- Medical equipment
- Office furniture

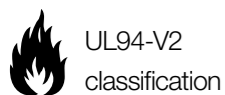

iF product design award  
2000 Series easy triflex®

Series	Inner height <i>Bi1 / Bi1</i> [mm]	Inner width <i>Bi3</i> [mm]	Outer width <i>Ba</i> [mm]	Bend radius <i>R</i> [mm]	Pitch [mm]	Page
--------	---------------------------------------	--------------------------------	-------------------------------	------------------------------	---------------	------



### Single-axis movement - "easy" design

easy filling from both sides

E332.25	13	25	34	048 - 200	14.5	946
E332.32	17	32	50	075 - 250	25	946
E332.50	26	50	68	100 - 250	30	946
E332.75	38.5	75	96	140 - 300	36	946



### Double-axis movement - "easy" design with RBR (Reverse Bend Radius)

easy filling from both sides

E332.25	13	25	34	048 - 200	14.5	947
E332.32	17	32	50	075 - 250	25	947
E332.50	26	50	68	100 - 250	30	947
E332.75	38.5	75	96	140 - 300	36	947



### Triple-axis movement - "easy" design with RBR (Reverse Bend Radius)

easy filling from both sides

E333.25	13	25	34	048 - 200	14.5	948
E333.32	17	32	50	075 - 250	25	948
E333.50	26	50	68	100 - 250	30	948
E333.75	38.5	75	96	140 - 300	36	948





Available from stock. Ready to ship in 24 - 48hrs.\*

\*The delivery times indicated correspond to the average time until the ordered goods are dispatched.



Technical data

	Speed / acceleration	upon request
	Material - permitted temperature °C, igumid NB	-40°C / +120°C
	Flammability class, igumid NB	VDE 0304 IIC UL94-V2

Order example | Order key

 Order example for complete e-chain® (1.0m), colour black, with mounting brackets:

e-chain® (1.0m)	Please indicate e-chain® length or number of links: 1.0m or 28 links	E333.75.200/200.0
+ Mounting brackets	1 set mounting bracket with strain relief	333.75.12PZ
Order text:	1 m E333.75.200/200.0 + 333.75.12PZ	

 Order key  
Single-axis movement

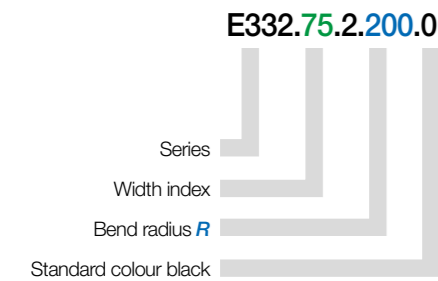

 Order key  
Double-axis movement

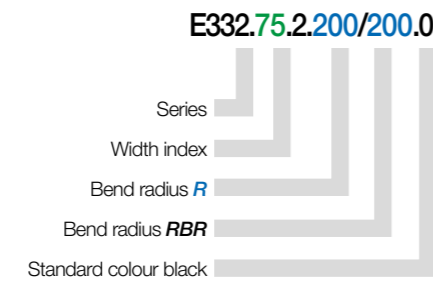

 Order key  
Triple-axis movement

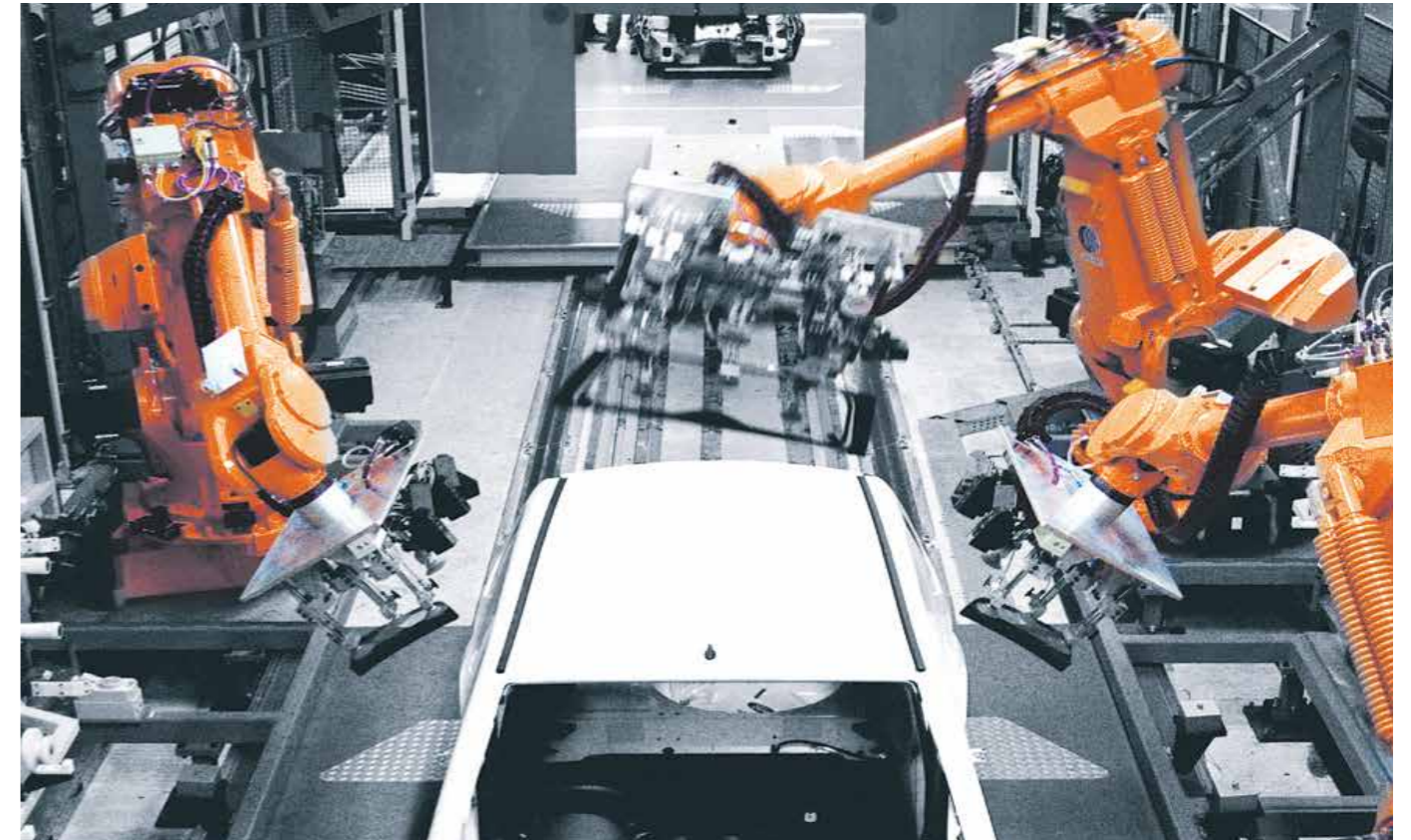
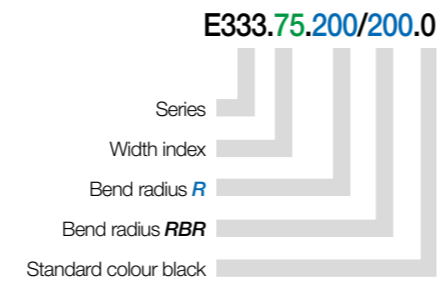

Robots with igus® easy triflex® e-chains® on an assembly line



igus® easy triflex® and E2 medium e-chain® in a production line



easy triflex® e-chains® can also be used for simple applications needing an aesthetic solution

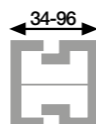

e-chains® | Series E332 "easy" design | Single-axis movement

Part No.	Bi1/Bi2	Bi3	Ba	R Available bend radii								Pitch	E332
				[mm]	[mm]	[mm]	[mm]	[mm]	[mm]	[mm]	[mm]		
E332.25.2 .R.0	13	25	34	048	075	100	125	150	175	200	14.5	≈ 0.70	
E332.32.2 .R.0	17	32	50	075	100	125	150	200	250	25	≈ 0.90		
E332.50.2 .R.0	26	50	68	100	125	150	200	250	30	≈ 1.40			
E332.75.2 .R.0	38.5	75	96	140	175	200	250	300	36	≈ 2.35			

Complete Part No. with required radius (R). Example: E332.75.2.200.0

Installation dimensions

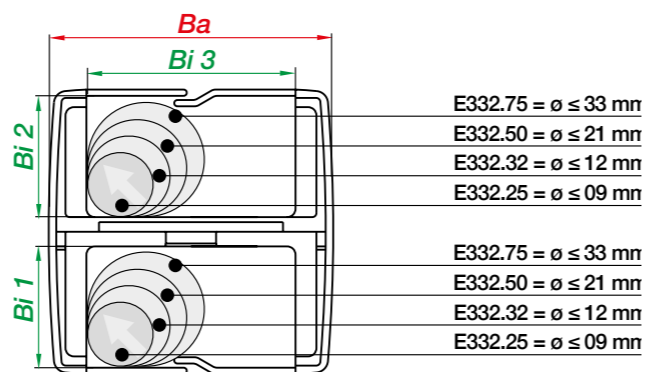
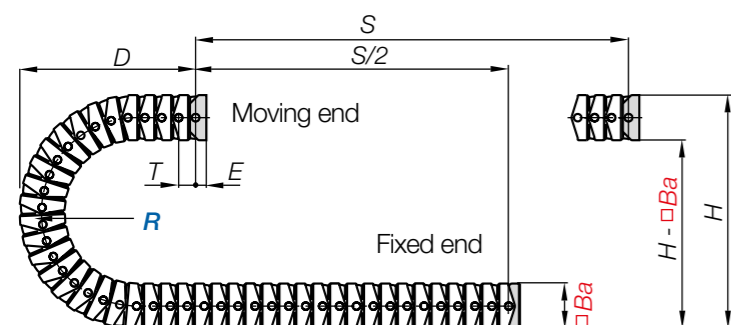

E332.25.2	R	048	075	100	125	150	175	200
	H	130	185	235	285	335	385	435
D	095	125	150	175	200	225	250	
K	195	280	360	440	515	595	675	
E332.32.2	R	075	100	125	150	200	250	
	H	200	250	300	350	450	550	
D	130	155	180	205	255	305		
K	305	385	465	545	700	865		
E332.50.2	R	100	125	150	200	250		
	H	270	320	375	470	570		
D	195	220	245	295	345			
K	435	520	590	750	910			
E332.75.2	R	140	175	200	250	300		
	H	380	450	500	600	700		
D	240	275	300	350	400			
K	550	660	740	900	1,060			

E332.25.2.	E332.32.2.		
Ba [mm]	34	Ba [mm]	50
Pitch T [mm/link]	14.5	Pitch T [mm/link]	25
Dim. E [mm]	10	Dim. E [mm]	20
Links/m	69	Links/m	40
corresponds to [mm]	1,000.5	corresponds to [mm]	1,000
e-chain® length $L_K = S/2 + K$		e-chain® length $L_K = S/2 + K$	
E332.50.2.	E332.75.2.		
Ba [mm]	68	Ba [mm]	96
Pitch T [mm/link]	30	Pitch T [mm/link]	36
Dim. E [mm]	25	Dim. E [mm]	25
Links/m	34	Links/m	28
corresponds to [mm]	1,020	corresponds to [mm]	1,008
e-chain® length $L_K = S/2 + K$		e-chain® length $L_K = S/2 + K$	



e-chains® | Series E332 "easy" design | Double-axis movement with RBR\*

Part No.	Bi1/Bi2	Bi3	Ba	R Available bend radii								Pitch	E332
				[mm]	[mm]	[mm]	[mm]	[mm]	[mm]	[mm]	[mm]		
E332.25.2 .R/R.0	13	25	34	048	075	100	125	150	175	200	14.5	≈ 0.70	
E332.32.2 .R/R.0	17	32	50	075	100	125	150	200	250	25	≈ 0.90		
E332.50.2 .R/R.0	26	50	68	100	125	150	200	250	30	≈ 1.40			
E332.75.2 .R/R.0	38.5	75	96	140	175	200	250	300	36	≈ 2.35			

\*RBR = Reverse Bend Radius

Complete Part No. with required radius (R). Example: E332.75.2.200/200.0

Installation dimensions

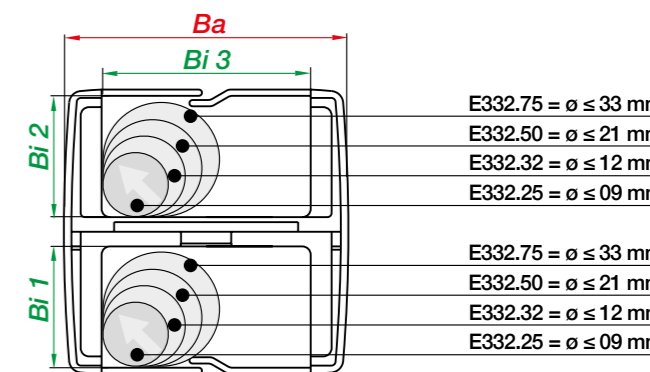
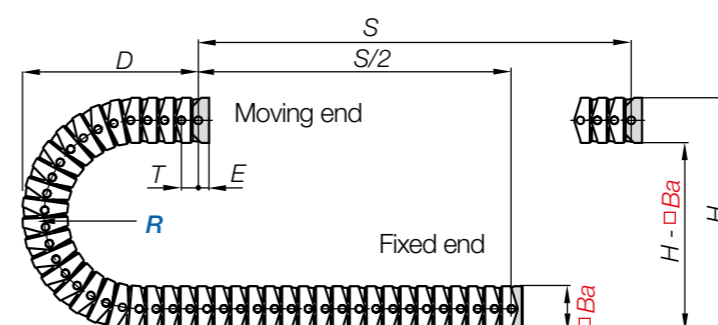

E332.25.2	R	048	075	100	125	150	175	200
	H	130	185	235	285	335	385	435
D	095	125	150	175	200	225	250	
K	195	280	360	440	515	595	675	
E332.32.2	R	075	100	125	150	200	250	
	H	200	250	300	350	450	550	
D	130	155	180	205	255	305		
K	305	385	465	545	700	865		
E332.50.2	R	100	125	150	200	250		
	H	270	320	375	470	570		
D	195	220	245	295	345			
K	435	520	590	750	910			
E332.75.2	R	140	175	200	250	300		
	H	380	450	500	600	700		
D	240	275	300	350	400			
K	550	660	740	900	1,060			

E332.25.2.	E332.32.2.		
Ba [mm]	34	Ba [mm]	50
Pitch T [mm/link]	14.5	Pitch T [mm/link]	25
Dim. E [mm]	10	Dim. E [mm]	20
Links/m	69	Links/m	40
corresponds to [mm]	1,000.5	corresponds to [mm]	1,000
e-chain® length $L_K = S/2 + K$		e-chain® length $L_K = S/2 + K$	
E332.50.2.	E332.75.2.		
Ba [mm]	68	Ba [mm]	96
Pitch T [mm/link]	30	Pitch T [mm/link]	36
Dim. E [mm]	25	Dim. E [mm]	25
Links/m	34	Links/m	28
corresponds to [mm]	1,020	corresponds to [mm]	1,008
e-chain® length $L_K = S/2 + K$		e-chain® length $L_K = S/2 + K$	



e-chains® | Series E333 "easy" design | Triple-axis movement with RBR\*

Part No.	Bi1/Bi2	Bi3	Ba	R Available bend radii	Pitch	E332
e-chains®	[mm]	[mm]	[mm]	[mm]	[mm]	[kg/m]
E333.25.R/R.0	13	25	34	048   075   100   125   150   175   200	14.5	≈ 0.70
E333.32.R/R.0	17	32	50	075   100   125   150   200   250	25	≈ 0.90
E333.50.R/R.0	26	50	68	100   125   150   200   250	30	≈ 1.40
E333.75.R/R.0	38.5	75	96	140   175   200   250   300	36	≈ 2.35

\*RBR = Reverse Bend Radius The bend radii are doubled in the case of the series E333

Complete Part No. with required radius (R). Example: E333.75.200/200.0

Installation dimensions<sub>S</sub>

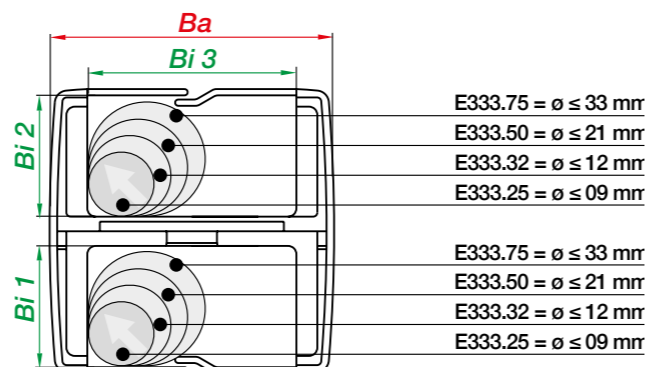
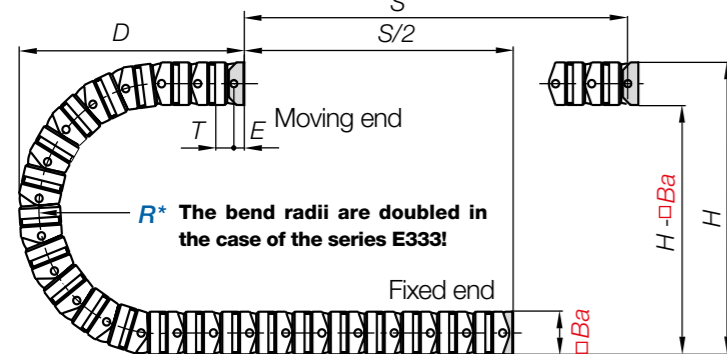

E333.25	R	048	075	100	125	150	175	200
	H	230	335	435	535	635	735	835
D	145	200	250	300	350	400	450	
K	350	515	675	830	990	1,150	1,300	
E333.32	R	075	100	125	150	200	250	
	H	350	450	550	650	850	1050	
D	205	255	305	355	455	555		
K	545	700	860	1,020	1,300	1,605		
E333.50	R	100	125	150	200	250		
	H	470	570	670	870	1070		
D	295	345	395	495	595			
K	750	910	1,070	1,380	1,690			
E333.75	R	140	175	200	250	300		
	H	660	800	900	1100	1300		
D	380	450	500	600	700			
K	990	1,210	1,400	1,700	2,000			

E333.25	E333.32		
Ba [mm]	34	Ba [mm]	50
Pitch T [mm/link]	14.5	Pitch T [mm/link]	25
Dim. E [mm]	10	Dim. E [mm]	20
Links/m	69	Links/m	40
corresponds to [mm]	1,000.5	corresponds to [mm]	1,000
e-chain® length $L_K = S/2 + K$		e-chain® length $L_K = S/2 + K$	

E333.50	E333.75		
Ba [mm]	68	Ba [mm]	96
Pitch T [mm/link]	30	Pitch T [mm/link]	36
Dim. E [mm]	25	Dim. E [mm]	25
Links/m	34	Links/m	28
corresponds to [mm]	1,020	corresponds to [mm]	1,008
e-chain® length $L_K = S/2 + K$		e-chain® length $L_K = S/2 + K$	

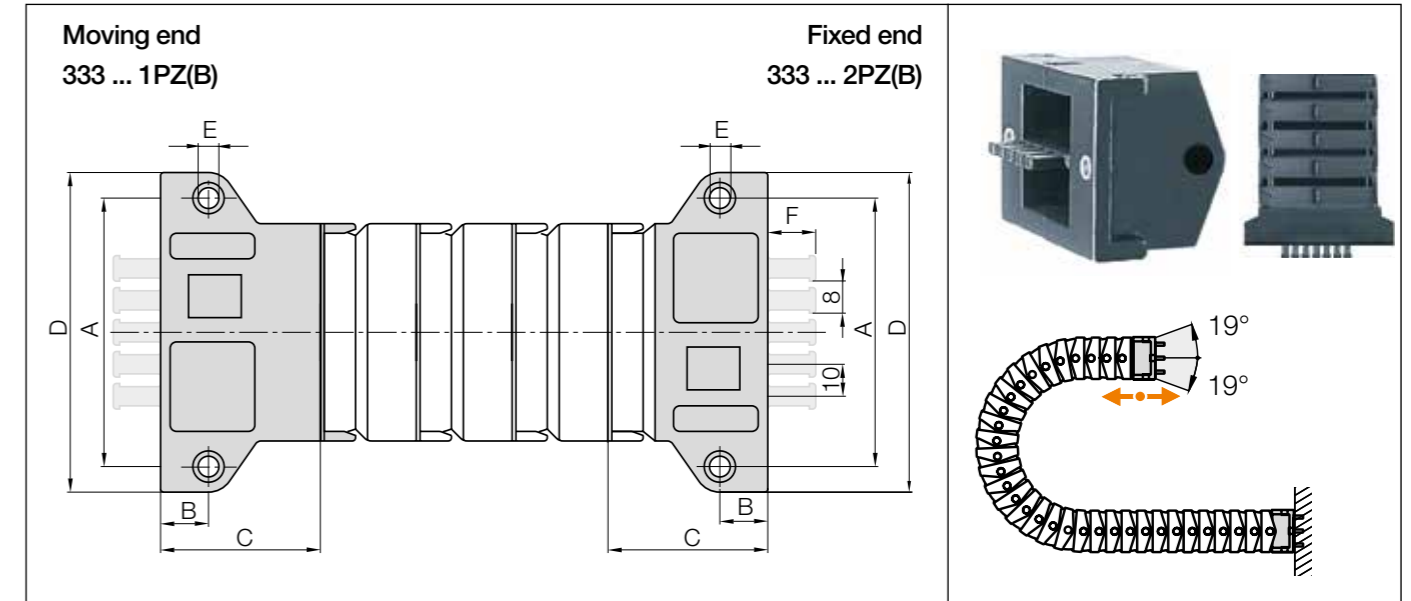

KMA, one end pivoting

Width index	Part No. full set with tiewrap plates	Part No. full set without tiewrap plates	A [mm]	B [mm]	C [mm]	D [mm]	E [mm]	F [mm]	Number of teeth
25.2 / 25.	-	333.25.12PZ	43	7	22	52	4.5	-	-
32.2 / 32.	333.32.12PZB	333.32.12PZ	66	15	46	82	6.5	15	3
50.2 / 50.	333.50.12PZB	333.50.12PZ	84	15	50	100	6.5	15	5
75.2 / 75.	333.75.12PZB	333.75.12PZ	109	15	55	125	6.5	15	7

Note series E333: the mounting brackets are only available for e-chains® with even number of chain links!

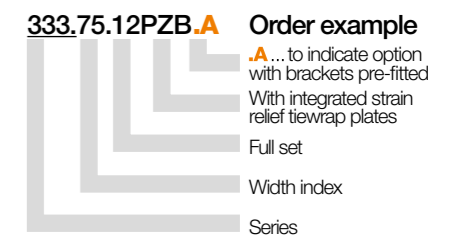
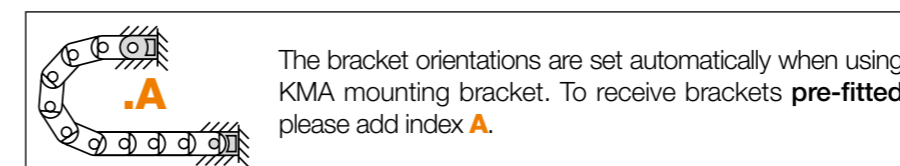

Strain relief e.g. clamps, tiewrap plates, nuggets and plug-in clips are available from stock. The complete chainfix range with ordering options ▶ From page 1300

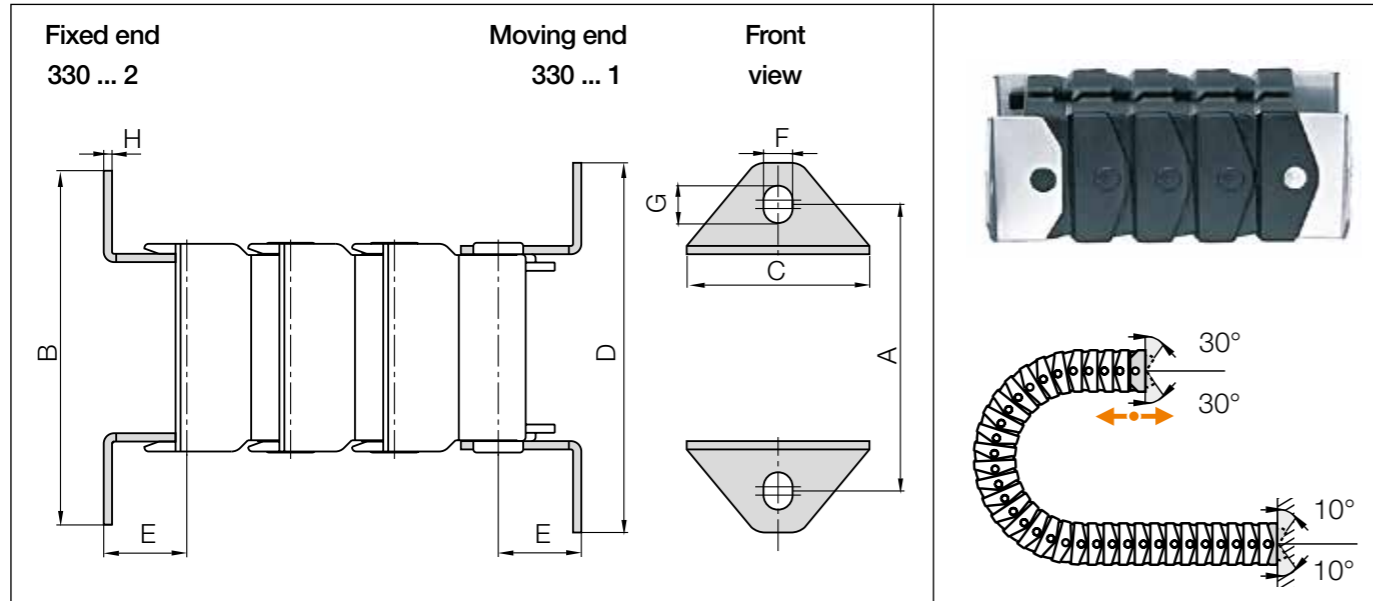

Mounting brackets, flange, steel | Pivoting

Width index	Part No. full set	A [mm]	B [mm]	C [mm]	D [mm]	E [mm]	F [mm]	G [mm]	H [mm]
25.2 / 25. ▶	<b>330.25.12</b>	44	55	29	55	10.5	6.5	9	1.5
32.2 / 32. ▶	<b>330.32.12</b>	66	84	44	88	20	7	9	2
50.2 / 50. ▶	<b>330.50.12</b>	84	102	62	106	25	7	9	2
75.2 / 75. ▶	<b>330.75.12</b>	109	127	90	131	25	7	9	2

Note series E333: the mounting brackets are only available for e-chains® with even number of chain links!

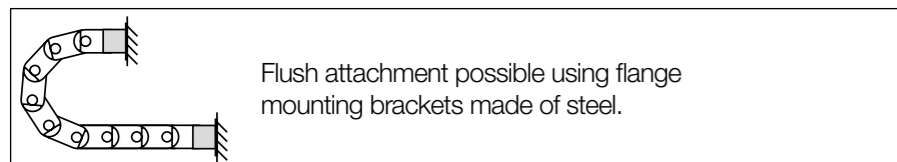

**330.75.12** Order example

- Full set
- Width index
- Series

**Strain relief** e.g. clamps, tiwrap plates, nuggets and plug-in clips are available from stock. The complete chainfix range with ordering options ▶ From page 1300

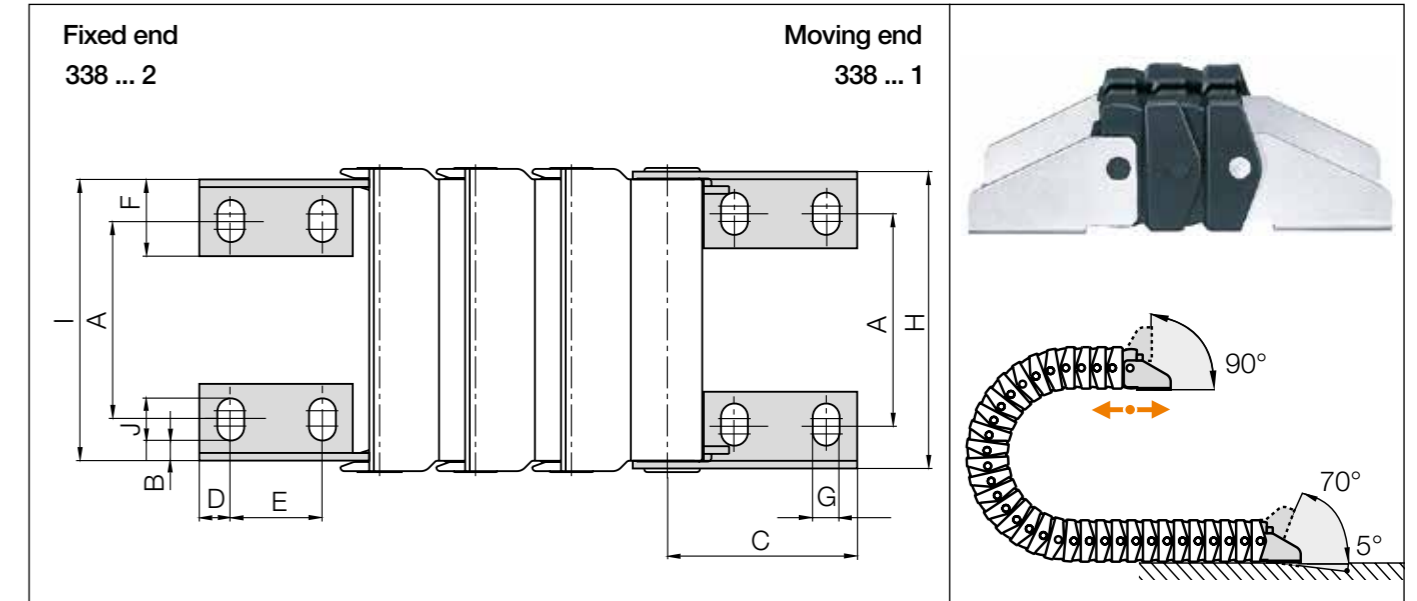

Mounting brackets, angled, steel | Pivoting

Width index	Part No. full set	A [mm]	B [mm]	C [mm]	D [mm]	E [mm]	F [mm]	G [mm]	H [mm]	I [mm]	J [mm]
25.2 / 25. ▶	<b>338.25.12</b>	17	6.25	28	6	16	14	5.5	33.8	31	8.5
32.2 / 32. ▶	<b>338.32.12</b>	24	5.5	47	8	24	20	7	49	45	11
50.2 / 50. ▶	<b>338.50.12</b>	42	5.5	77	12	35	24	9	67	62	15
75.2 / 75. ▶	<b>338.75.12</b>	65	5.5	77	12	35	24	9	95	90	15

Note series E333: the mounting brackets are only available for e-chains® with even number of chain links!

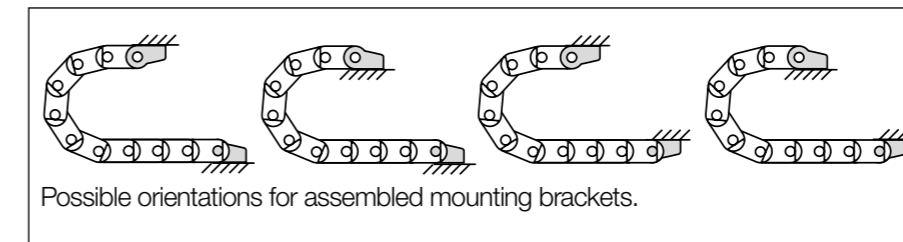

**338.75.12** Order example

- Full set
- Width index
- Series

**Strain relief** e.g. clamps, tiwrap plates, nuggets and plug-in clips are available from stock. The complete chainfix range with ordering options ▶ From page 1300



# triflex<sup>®</sup>

## Enclosed for simple multi-axis applications



**triflex<sup>®</sup> advantages:**

- For single, double and triple-axis applications  
(combines circular and linear movements)
- If swarf protection is required
- If square space is required
- For simple multi-axis applications
- High strength



**When to use another multi-axis e-chain<sup>®</sup> series:**

- For complex robot applications
  - ▶ triflex<sup>®</sup> R - TRE, page 866
- For circular movements with high loads
  - ▶ twisterchain system, page 966

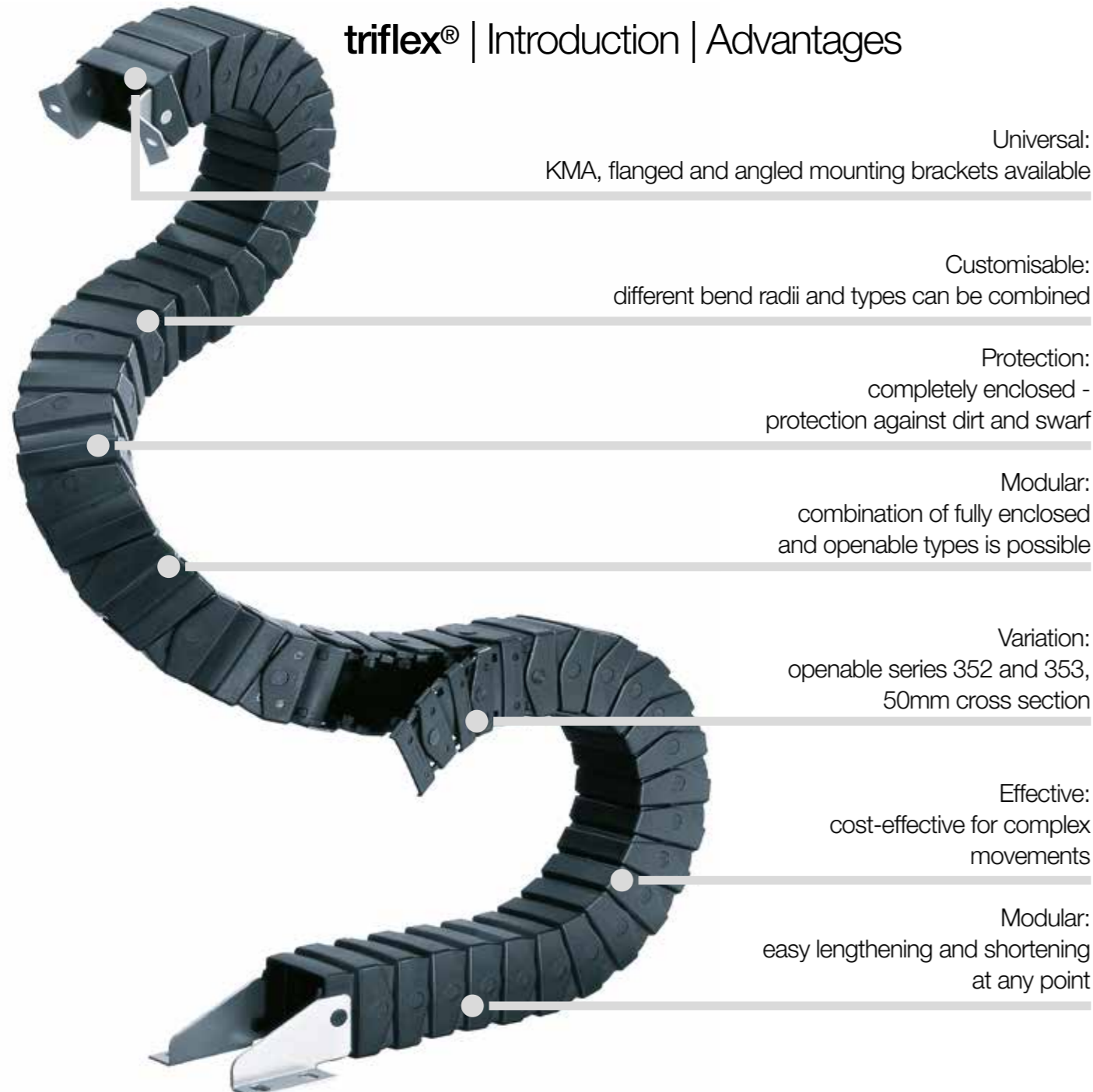

Universal:  
KMA, flanged and angled mounting brackets available

Customisable:  
different bend radii and types can be combined

Protection:  
completely enclosed -  
protection against dirt and swarf

Modular:  
combination of fully enclosed  
and openable types is possible

Variation:  
openable series 352 and 353,  
50mm cross section

Effective:  
cost-effective for complex  
movements

Modular:  
easy lengthening and shortening  
at any point

## Enclosed for simple multi-axis applications - triflex®

The triflex® series was developed to allow safe energy supply for multi-axis movements. In doing so the flexibility of a hose was combined with the stability and defined bend radius of an e-chain®. The unique, modular product range allows very complex motions. For example it is possible to combine 1- 2- and 3-axis links in one e-chain®.

### Typical industries and applications

- Machine tools ● Robots ● Material handling ● Plastics industry ● Construction machinery ● Vehicles production ● Medical equipment ● General mechanical engineering, etc.



Series	Inner width <i>Bi</i> [mm]	Outer width <i>Ba</i> [mm]	Bend radius <i>R</i> [mm]	Pitch [mm]	Page
--------	-------------------------------	-------------------------------	------------------------------	---------------	------



**Single-axis movement - enclosed**  
protection against dirt and swarf

332.16	16	26	038 - 100	13.3	958
332.32	32	50	075 - 250	25	958
332.50	50	68	100 - 250	30	958
332.75	75	96	140 - 300	36	958
352.50*	50	68	100 - 250	30	958



**Double-axis movement - enclosed,  
with RBR (Reverse Bend Radius)**  
protection against dirt and swarf

332.16	16	26	038 - 100	13.3	960
332.32	32	50	075 - 250	25	960
332.50	50	68	100 - 250	30	960
332.75	75	96	140 - 300	36	960
352.50*	50	68	100 - 250	30	960



**Triple-axis movement - enclosed,  
with RBR (Reverse Bend Radius)**  
protection against dirt and swarf

333.16	16	26	038 - 100	13.3	961
333.32	32	50	075 - 250	25	961
333.50	50	68	100 - 250	30	961
333.75	75	96	140 - 300	36	961
353.50*	50	68	100 - 250	30	961

\*Series 352/353 openable



Available from stock. Ready to ship in 24 - 48hrs.\*

\*The delivery times indicated correspond to the average time until the ordered goods are dispatched.



Technical data

	Speed / acceleration	upon request
	Material - permitted temperature °C, igumid G	-40°C / +120°C
	Flammability class, igumid G	VDE 0304 IIC UL94-HB

Order example | Order key

 Order example for complete e-chain® (1.0m), colour black, with mounting brackets:

e-chain® (1.0m)	Please indicate e-chain® length or number of links: 1.0m or 28 links	333.75.200/200.0
+ Mounting brackets	1 set mounting bracket with strain relief	333.75.12PZ
+ Interior separation	with 2 separators assembled every 2 <sup>nd</sup> link	351
Order text:	333.75.200/200.0 + 333.75.12PZ + 351	

 Order key  
Single-axis movement

332.75.200.0  
352.50.200.0

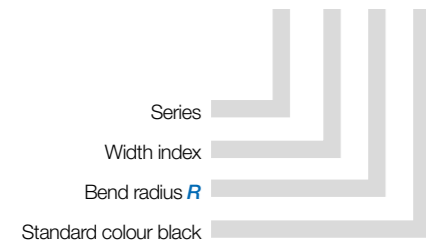

 Order key  
Double-axis movement

332.75.200/200.0  
352.75.200/200.0



 Order key  
Triple-axis movement

333.75.200/200.0  
353.75.200/200.0



Various triflex® e-chains® on a machining centre



triflex® allows combination of links for triple-axis and single-axis movement



triflex® 332 as unsupported link from machines to control panel



e-tubes | 332 enclosed | 352 openable | Single-axis movement

Part No.	Part No.	Bi	Ba	R Available bend radii	Pitch	Weight
enclosed version	openable version	[mm]	[mm]	[mm]	[mm]	[kg/m]
332.16.R.0	-	16	26	038   048   075   100	13.3	0.33
332.32.R.0	-	32	50	075   100   125   150   200   250	25	0.90
332.50.R.0	352.50.R.0	50	68	100   125   150   200   250	30	1.40
332.75.R.0	-	75	96	140   175   200   250   300	36	2.35

Complete Part No. with required radius (R). Example: 332.75.200.0

Installation dimensions

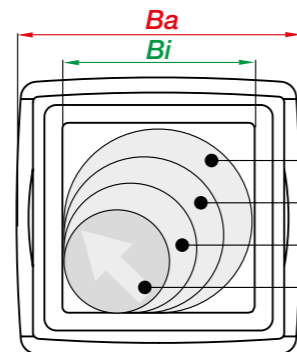
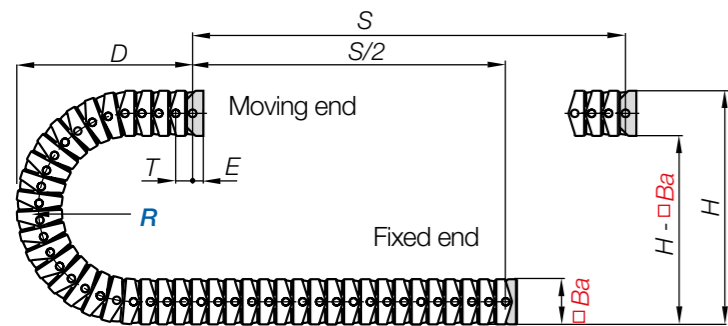

332.16	R	038	048	075	100		
	H	105	125	180	230		
	D	070	080	105	130		
	K	200	230	315	400		
332.32	R	075	100	125	150	200	250
	H	200	250	300	350	450	550
	D	130	155	180	205	255	305
	K	305	385	465	545	700	865
332.50 352.50	R	100	125	150	200	250	
	H	270	320	375	470	570	
	D	195	220	245	295	345	
332.75	R	140	175	200	250	300	
	H	380	450	500	600	700	
	D	240	275	300	350	400	
	K	550	660	740	900	1,060	

<b>332.16</b>	<b>332.32</b>		
Ba [mm]	26	Ba [mm]	50
Pitch T [mm/link]	13.3	Pitch T [mm/link]	25
Dim. E [mm]	10	Dim. E [mm]	20
Links/m	76	Links/m	40
corresponds to [mm]	1,011	corresponds to [mm]	1,000
e-chain® length $L_K = S/2 + K$		e-chain® length $L_K = S/2 + K$	

<b>332.50/352.50</b>	<b>332.75</b>		
Ba [mm]	68	Ba [mm]	96
Pitch T [mm/link]	30	Pitch T [mm/link]	36
Dim. E [mm]	25	Dim. E [mm]	25
Links/m	34	Links/m	28
corresponds to [mm]	1,020	corresponds to [mm]	1,008
e-chain® length $L_K = S/2 + K$		e-chain® length $L_K = S/2 + K$	

Unsupported length 332.16

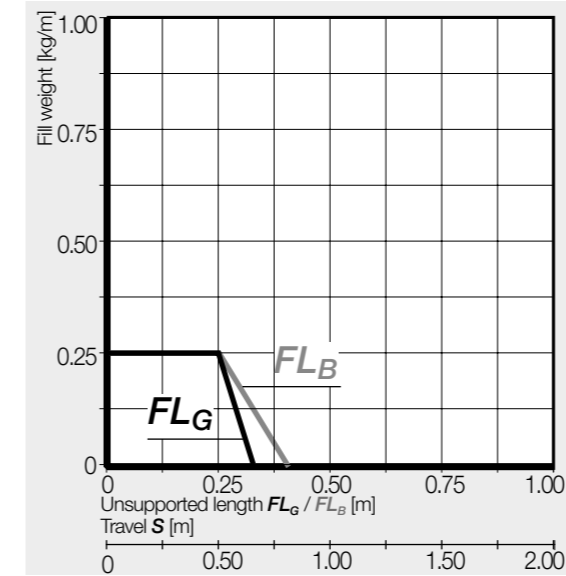

Unsupported length 332.32

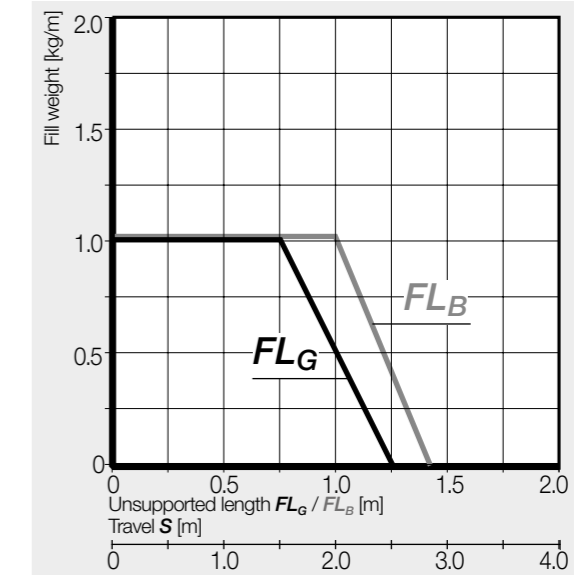

Unsupported length 332.50/352.50

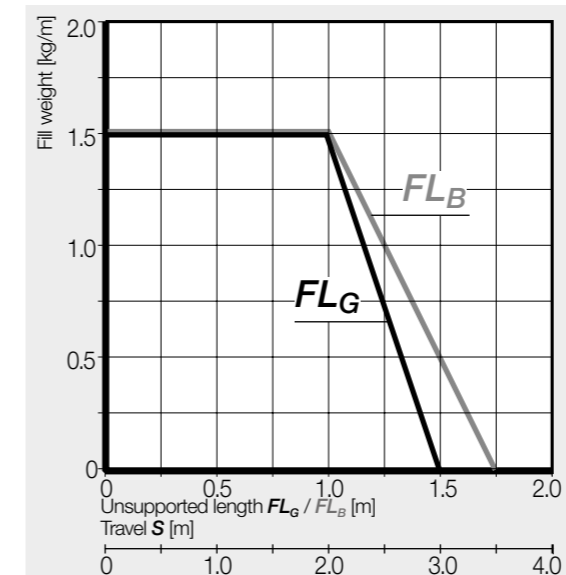

Unsupported length 332.75

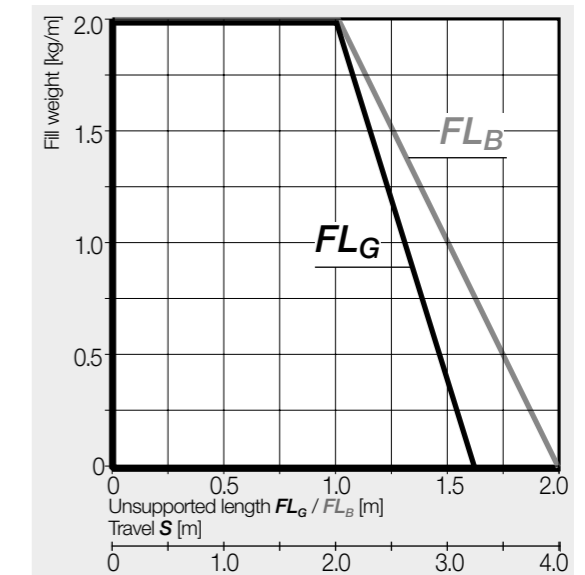



e-tubes | 332 enclosed | 352 openable | Double-axis movement with RBR\*

Part No. enclosed version	Part No. openable version	Bi [mm]	Ba [mm]	R Available bend radii [mm]	Pitch [mm]	Weight [kg/m]
332.16.R/R.0	-	16	26	038   048   075   100	13.3	0.33
332.32.R/R.0	-	32	50	075   100   125   150   200   250	25	0.90
332.50.R/R.0	352.50.R/R.0	50	68	100   125   150   200   250	30	1.40
332.75.R/R.0	-	75	96	140   175   200   250   300	36	2.35

\*RBR = Reverse Bend Radius

Art. Complete Part No. with required radius (R). Example: 332.75.200/200.0

Installation dimensions

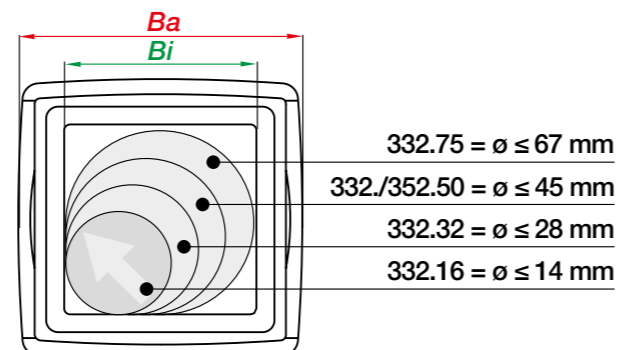
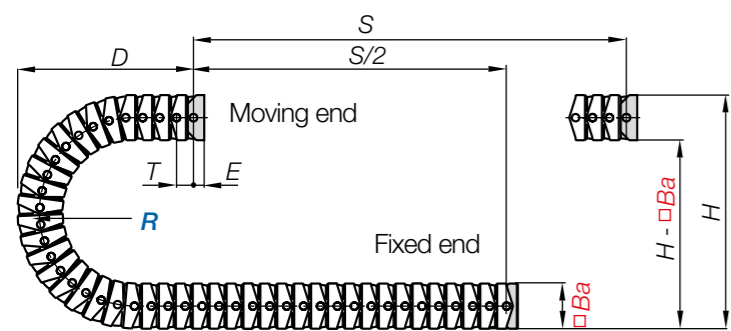

Series	R	038	048	075	100		
	332.16	H	105	125	180	230	
	D	070	080	105	130		
	K	200	230	315	400		
Series	R	075	100	125	150	200	250
	332.32	H	200	250	300	350	450
	D	130	155	180	205	255	305
	K	305	385	465	545	700	865
Series	R	100	125	150	200	250	
	332.50 352.50	H	270	320	375	470	570
	D	195	220	245	295	345	
	K	435	520	590	750	910	
Series	R	140	175	200	250	300	
	332.75	H	380	450	500	600	700
	D	240	275	300	350	400	
	K	550	660	740	900	1,060	

Series	R	038	048	075	100		
332.16	H	180	220	330	430		
	D	105	125	180	230		
	K	320	380	550	710		
Series	R	075	100	125	150	200	250
	332.32	H	350	450	550	650	850
	D	205	255	305	355	455	555
	K	545	700	860	1,020	1,300	16
Series	R	100	125	150	200	250	
	332.50 352.50	H	470	570	670	870	1,070
	D	295	345	395	495	595	
	K	750	910	1,070	1,380	1,690	
Series	R	140	175	200	250	300	
	332.75	H	660	800	900	1,100	1,300
	D	380	450	500	600	700	
	K	990	1,210	1,400	1,700	2,000	

Series	R	038	048	075	100		
332.75	H	180	220	330	430		
	D	105	125	180	230		
	K	320	380	550	710		
Series	R	075	100	125	150	200	250
	333.32	H	350	450	550	650	850
	D	205	255	305	355	455	555
	K	545	700	860	1,020	1,300	16
Series	R	100	125	150	200	250	
	333.50 353.50	H	470	570	670	870	1,070
	D	295	345	395	495	595	
	K	750	910	1,070	1,380	1,690	
Series	R	140	175	200	250	300	
	333.75	H	660	800	900	1,100	1,300
	D	380	450	500	600	700	
	K	990	1,210	1,400	1,700	2,000	

e-chain® length  $L_K = S/2 + K$



e-tubes | 333 enclosed | 353 openable | Triple-axis movement with RBR\*

Part No. enclosed version	Part No. openable version	Bi [mm]	Ba [mm]	R Available bend radii [mm]	Pitch [mm]	Weight [kg/m]
333.16.R/R.0	-	16	26	038   048   075   100	13.3	0.33
333.32.R/R.0	-	32	50	075   100   125   150   200   250	25	0.90
333.50.R/R.0	353.50.R/R.0	50	68	100   125   150   200   250	30	1.40
333.75.R/R.0	-	75	96	140   175   200   250   300	36	2.35

\*RBR = Reverse Bend Radius The bend radii are doubled in the case of the series 333/353

Complete Part No. with required radius (R). Example: 333.75.200/200.0

Installation dimensions<sub>S</sub>

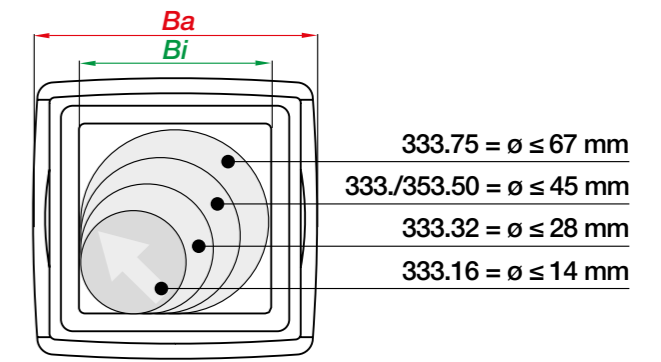
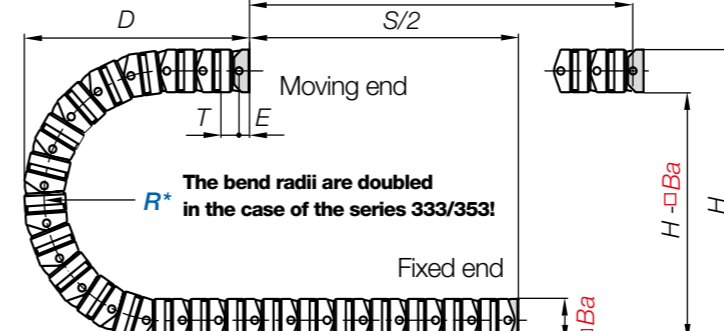

Series	R	038	048	075	100		
	333.16	H	180	220	330	430	
	D	105	125	180	230		
	K	320	380	550	710		
Series	R	075	100	125	150	200	250
	333.32	H	350	450	550	650	850
	D	205	255	305	355	455	555
	K	545	700	860	1,020	1,300	16
Series	R	100	125	150	200	250	
	333.50 353.50	H	470	570	670	870	1,070
	D	295	345	395	495	595	
	K	750	910	1,070	1,380	1,690	
Series	R	140	175	200	250	300	
	333.75	H	660	800	900	1,100	1,300
	D	380	450	500	600	700	
	K	990	1,210	1,400	1,700	2,000	

Series	R	038	048	075	100		
333.16	H	180	220	330	430		
	D	105	125	180	230		
	K	320	380	550	710		
Series	R	075	100	125	150	200	250
	333.32	H	350	450	550	650	850
	D	205	255	305	355	455	555
	K	545	700	860	1,020	1,300	16
Series	R	100	125	150	200	250	
	333.50 353.50	H	470	570	670	870	1,070
	D	295	345	395	495	595	
	K	750	910	1,070	1,380	1,690	
Series	R	140	175	200	250	300	
	333.75	H	660	800	900	1,100	1,300
	D	380	450	500	600	700	
	K	990	1,210	1,400	1,700	2,000	

e-chain® length  $L_K = S/2 + K$

# triflex® | Series 332·333·352·353 | Accessories

## KMA mounting brackets | Attachment from any side | One end pivoting

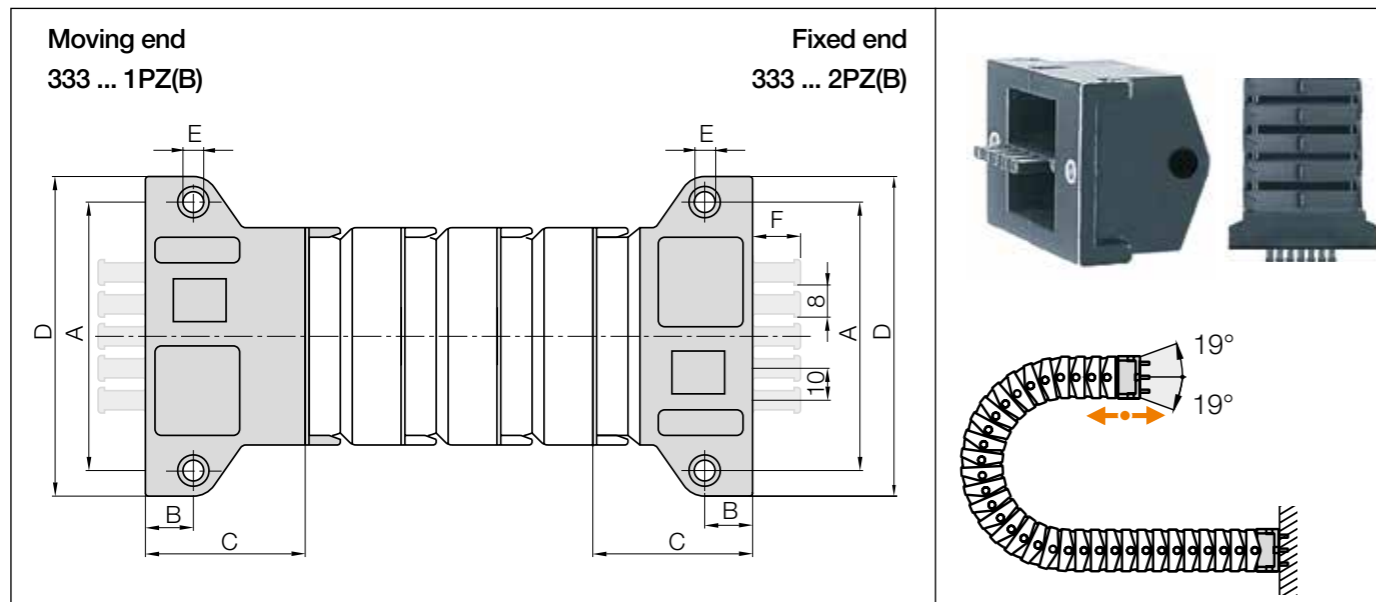

### KMA mounting brackets | One end pivoting

Width index	Part No. full set with tiewrap plates	Part No. full set without tiewrap plates	A [mm]	B [mm]	C [mm]	D [mm]	E [mm]	F [mm]	Number of teeth
32.	▶ 333.32.12PZB	333.32.12PZ	66	15	46	82	6.5	15	3
50.	▶ 333.50.12PZB	333.50.12PZ	84	15	50	100	6.5	15	5
75.	▶ 333.75.12PZB	333.75.12PZ	109	15	55	125	6.5	15	7

**Note series 333:** the mounting brackets are only available for e-chains® with even number of chain links!

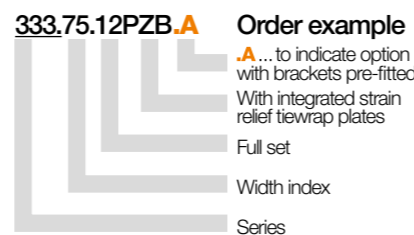
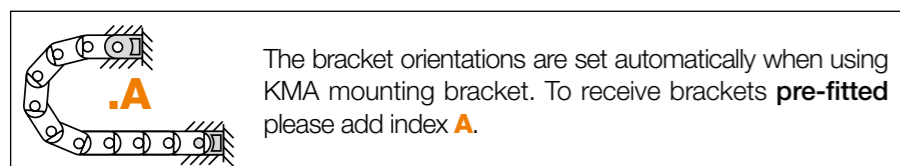

 **Strain relief** e.g. clamps, tiewrap plates, nuggets and plug-in clips are available from stock. The complete chainfix range with ordering options ▶ From page 1300

# triflex® | Series 332·333·352·353 | Accessories

## Mounting brackets, flange, steel | Pivoting

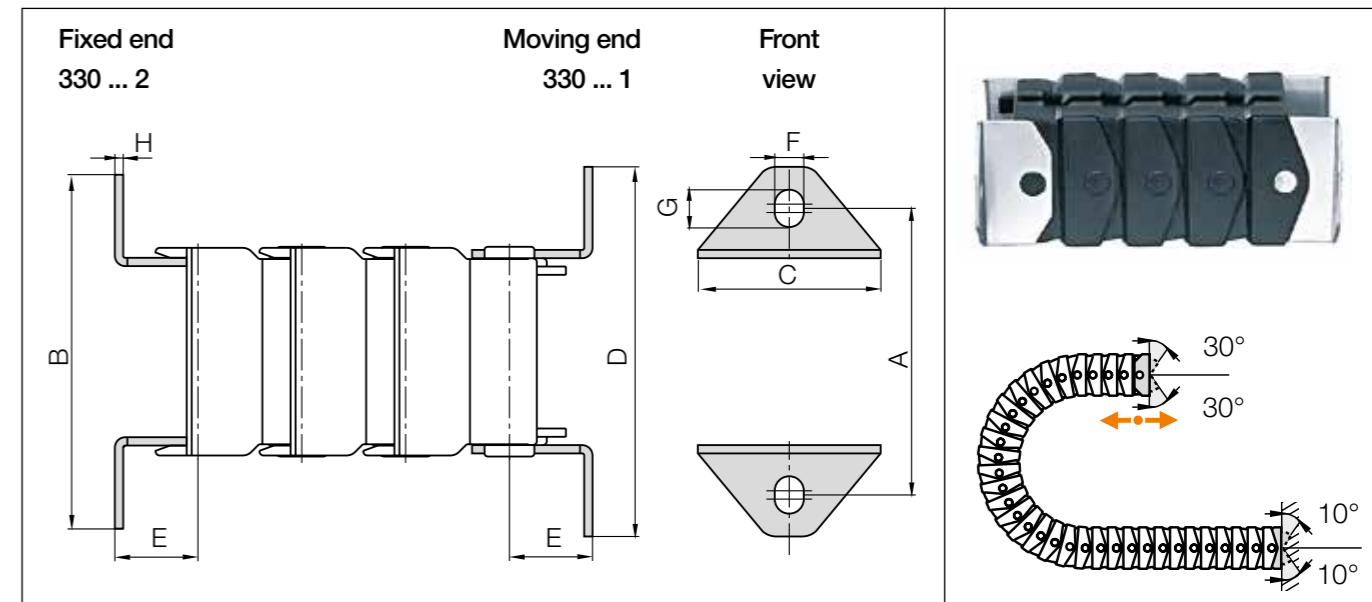

### Mounting brackets, flange, steel | Pivoting

Width index	Part No. full set	A [mm]	B [mm]	C [mm]	D [mm]	E [mm]	F [mm]	G [mm]	H [mm]
16.	▶ 330.16.12	35	53	21	57	10	4.5	6	1
32.	▶ 330.32.12	66	84	44	88	20	7	9	2
50.	▶ 330.50.12	84	102	62	106	25	7	9	2
75.	▶ 330.75.12	109	127	90	131	25	7	9	2

**Note series 333:** the mounting brackets are only available for e-chains® with even number of chain links!

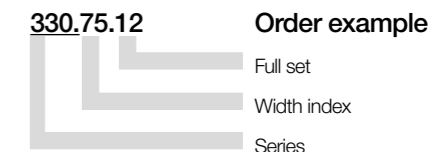
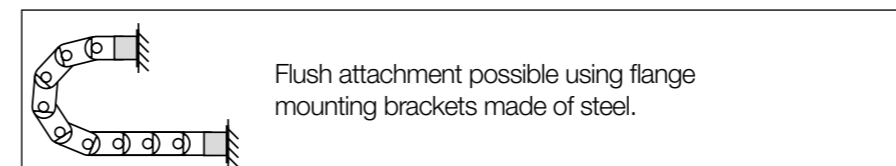

 **Strain relief** e.g. clamps, tiewrap plates, nuggets and plug-in clips are available from stock. The complete chainfix range with ordering options ▶ From page 1300

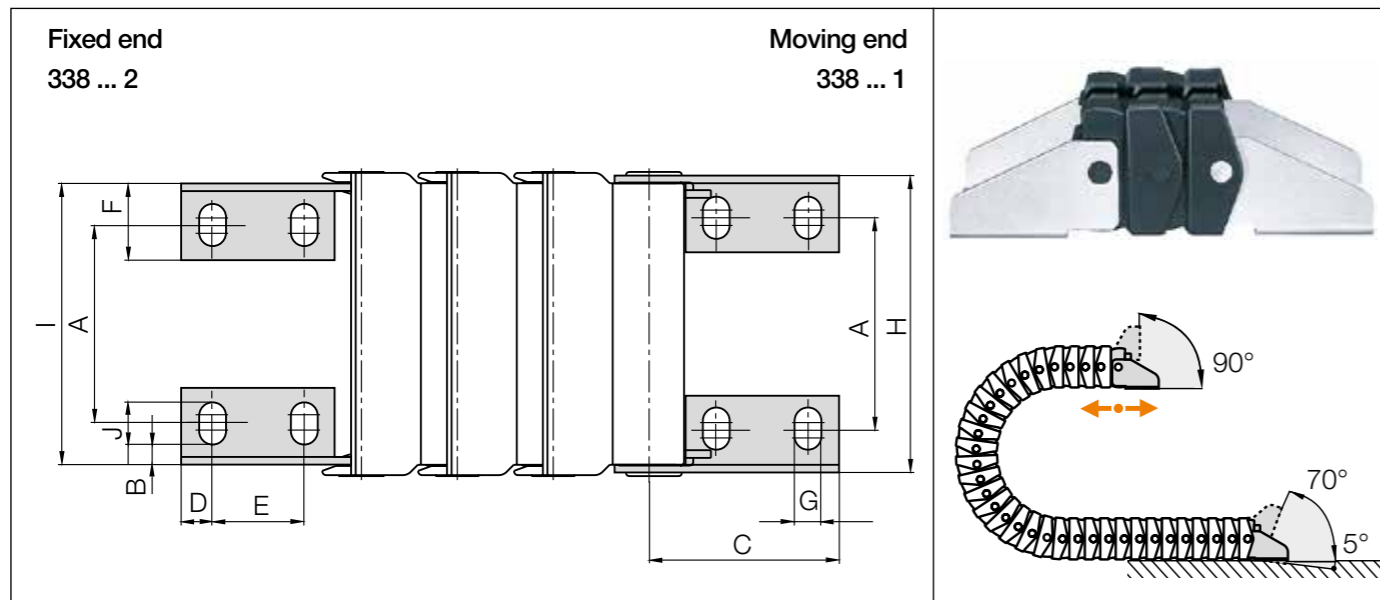

Mounting brackets, angled, steel | Pivoting

Width index	Part No. full set	A [mm]	B [mm]	C [mm]	D [mm]	E [mm]	F [mm]	G [mm]	H [mm]	I [mm]	J [mm]
16.	▶ 338.16.12	12	3	25	5	10	11	4.5	25	23	6
32.	▶ 338.32.12	24	5.5	47	8	24	20	7	49	45	11
50.	▶ 338.50.12	42	5.5	77	12	35	24	9	67	62	15
75.	▶ 338.75.12	65	5.5	77	12	35	24	9	95	90	15

**Note series 333:** the mounting brackets are only available for e-chains® with even number of chain links!

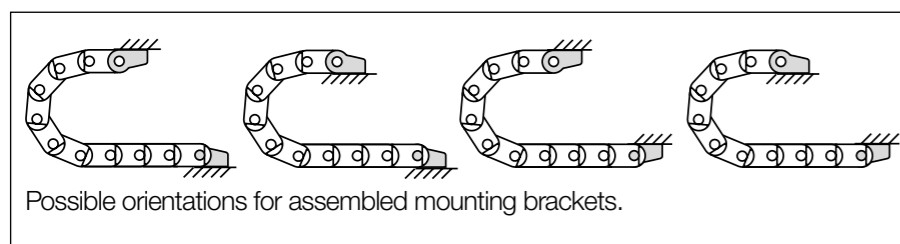

**338.75.12** Order example  
 Full set  
 Width index  
 Series

**Strain relief** e.g. clamps, tiwrap plates, nuggets and plug-in clips are available from stock. The complete chainfix range with ordering options ▶ From page 1300

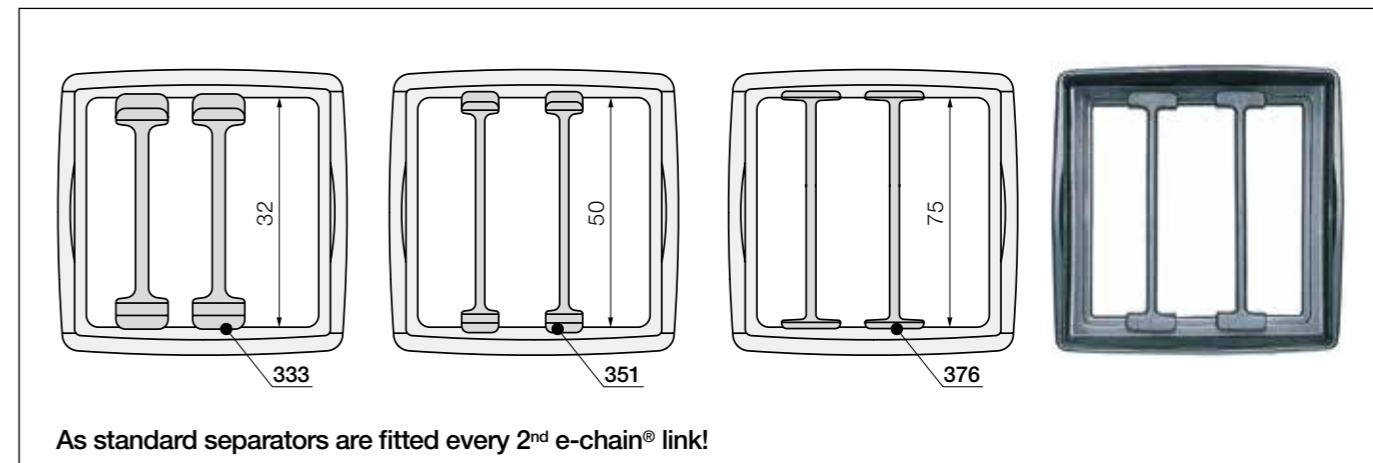

		For 332.32/333.32 unassembled <b>332</b> assembled <b>333</b>
		For 332.50/333.50/ 352.50/353.50 unassembled <b>350</b> assembled <b>351</b>
		For 332.75/333.75 unassembled <b>375</b> assembled <b>376</b>

**Separators**

Modular separators are available as interior separation for the igus® triflex® system. They can be used for both vertical and horizontal subdivision. If the separators are assembled every other link and turned 90°, the e-tube can be subdivided into four segments. We recommend ordering the separators pre-fitted, as fitting of separators is only possible after dismantling the e-tube.



# twisterchain

## Circular and spiral movements



### twisterchain advantages:

- e-chains® for circular and spiral movements up to 360°\* available from stock
- Tough, quiet and high dynamics, suitable for high fill weights
- Rotary speeds up to 1m/s and more
- Modular interior separation
- Smooth cable-friendly interior
- Openable from both sides - crossbars removable along the inner and outer radius



### When to use another igus® solution:

- For large rotary movements, igus® **RBR** solutions
  - ▶ **Designing, page 126**
- In case of rotary movements in the most confined spaces up to 7,000°
  - ▶ **twisterband, page 988**
- For angle of rotation >360° please contact us.

\*Up to 540° upon request

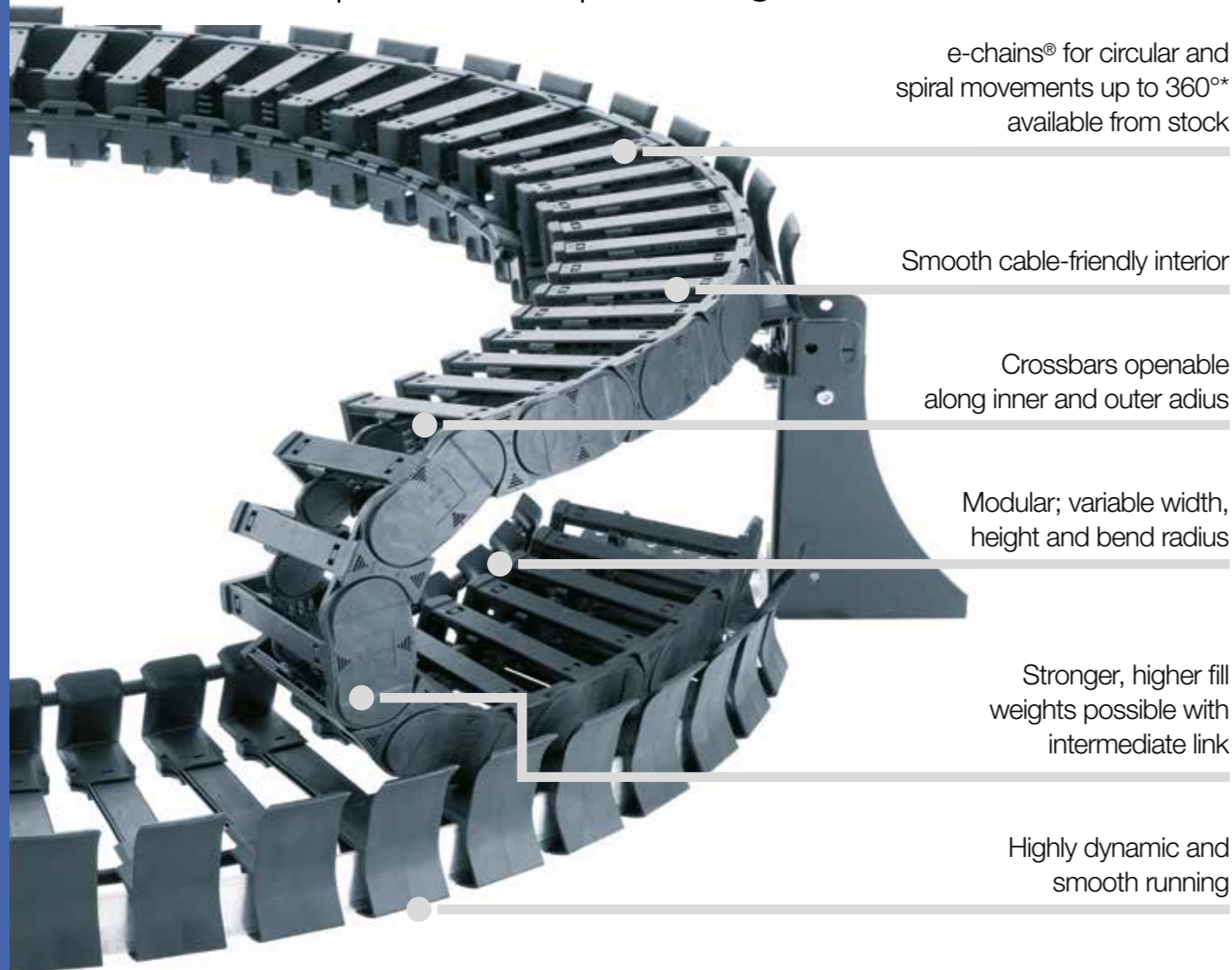

e-chains® for circular and spiral movements up to 360°\* available from stock

Smooth cable-friendly interior

Crossbars openable along inner and outer adius

Modular; variable width, height and bend radius

Stronger, higher fill weights possible with intermediate link

Highly dynamic and smooth running

## Strong, quiet and up to 360°\* - circular and spiral movements with twisterchain

The igus® twisterchain product line offers an extensive range of products for circular movement and is available in four sizes. Its modular width and radius design ensures it can be used flexibly in applications with rotary and spiral movements up to 360° and more, with high fill weights and where smooth operation is required. twisterchain applications are available with modular guide troughs which offer: e-chain® guidance, reduced e-chain® wear, optimal levels of smooth operation, angle of rotations up to 360°\* from stock.

- Strong, high fill weights, smooth running
- Rotary speeds up to 1m/s and more
- e-chains® for circular and spiral movements up to 360°\*available from stock
- Cable-friendly, smooth interior ● Crossbars openable along the inner and outer radius
- Successfully tested for over 1 million cycles in the igus® laboratory

\*Up to 540° upon request

### Typical industries and applications

- Robots, Handling machines ● Packaging machines ● Glass machines ● General machinery, etc.

 e-chains® for circular movements up to 360° available from stock (up to 540° upon request)

 UL94-V0 classification upon request

Series	Inner height <i>hi</i> [mm]	Inner width <i>Bi</i> [mm]	Outer width <i>Ba</i> [mm]	Outer height <i>ha</i> [mm]	Bend radius <i>R</i> [mm]	Circular radii <i>AR</i> [mm]	Page
--------	--------------------------------	-------------------------------	-------------------------------	--------------------------------	------------------------------	----------------------------------	------

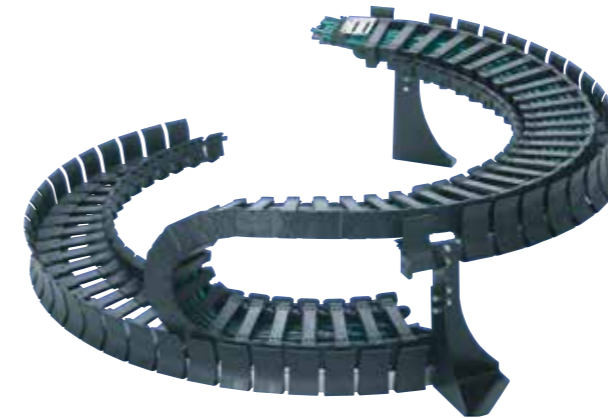

### twisterchain

For circular movements up to 360° available from stock; for angle of rotation >360° please contact us. Crossbars removable along the inner and outer radius

2208.*	28	52.5 - 112.5	80 - 140	42	055 - 150	300	972
TC32	32	87.5 - 150	108.5 - 171	54	100 - 250	400 - 600	974
TC42	42	87.5 - 200	110.5 - 223	64	100 - 250	400 - 850	976
TC56	56	125 - 200	155 - 230	84	150 - 400	650 - 850	978

\*twisterchain classic (1<sup>st</sup> generation), openable from both sides



Available from stock. Ready to ship in 24 - 48hrs.\*

\*The delivery times indicated correspond to the average time until the ordered goods are dispatched.

### Quickly generate complete twisterchain 3D CAD models

- Get complete 3D models just by inputting the angle of rotation and basic dimensions
- Free positioning of the e-chain® moving end along the travel length
- Optional generation of twisterchain as an individual part or complete with guide trough and base support
- Fast download of the CAD files without registration
- 11 different 3D formats and 8 different 2D formats available

More information ► [www.igus.eu/twister-configurator](http://www.igus.eu/twister-configurator)

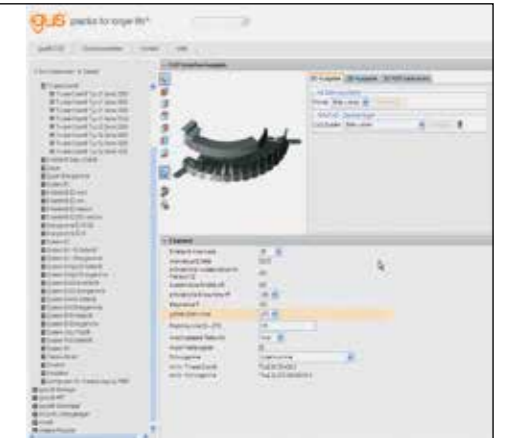

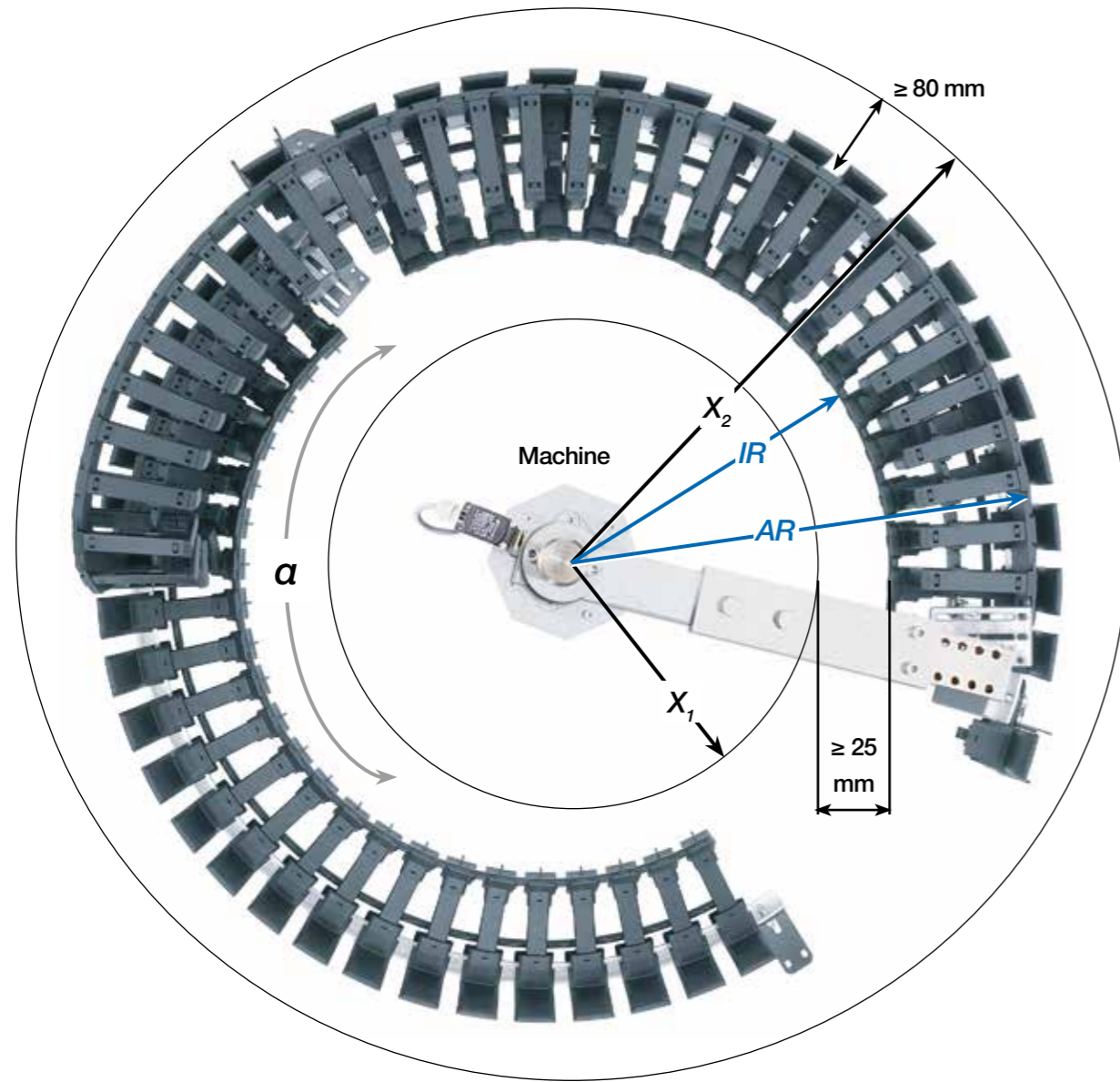

**twisterchain general information**

In the case of machines which rotate in one direction then the other, the total rotation angle required is the sum of the two angles.

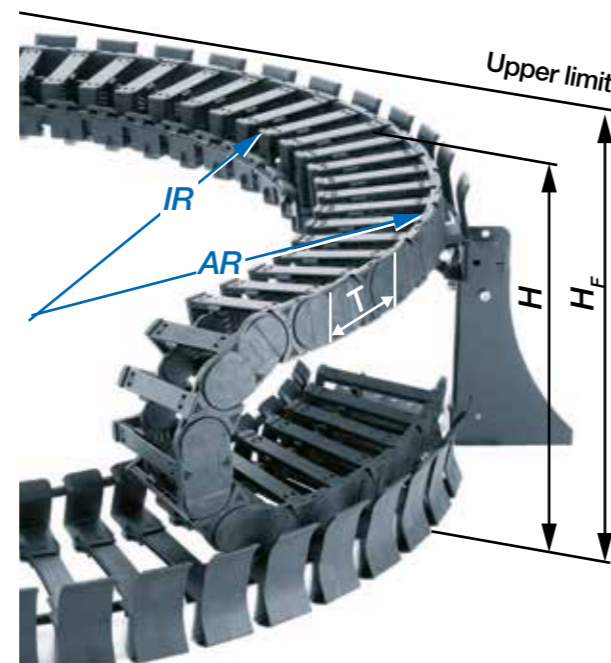
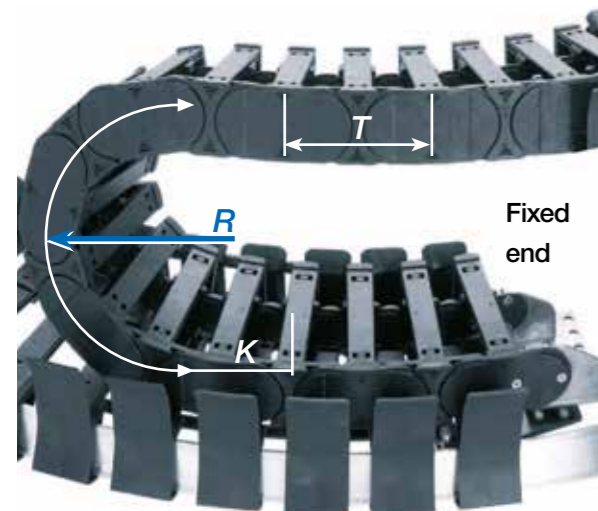

- i** AR = Outer radius of e-chain®
- IR = Inner radius e-chain®
- R = Bend radius e-chain®
- X<sub>1</sub> = Inner machine limit
- X<sub>2</sub> = Outer machine limit
- T = Pitch

- H<sub>F</sub> = e-chain® height incl. 50mm clearance
- H = e-chain® height
- K = Add-on for bend radius
- hi = Inner height e-chain®
- ha = Outer height e-chain®
- α = Rotation angle

**Technical data**

	Speed / acceleration	upon request
	Material - permitted temperature °C, igumid G	-40°C / +120°C
	Flammability class, igumid G	VDE 0304 IIC UL94-HB

**Order example | Order key**

Order example for complete e-chain® (1.0m), colour black, with mounting brackets:

e-chain® (1.0m)	Please indicate e-chain® length or number of links: 1.0m or 11 links	TC56.12.250/650.0
+ Mounting brackets	1 set	TC5600.34.VS.E
Order text:	1 m TC56.12.250/650.0 + TC5600.34.VS.E	

Order key **TC56.12.250/650.0**

Series	TC56
Inner height	12
Width index (depends on Bi)	250
Bend radius R	650
Outer radius AR	0
Standard colour black	0

**TC56.12.250/650.0 =**  
 e-chain® openable along the inner radius, from both sides  
 Bi 12mm inner width, R 250mm bend radius /  
 AR 650mm outer radius, colour black





Series 2208 | Crossbars removable along the inner and outer radius

AR	IR	Bi	Ba	R 055 [mm]	R 063 [mm]	R 075 [mm]	R 100 [mm]	R 125 [mm]	R 150 [mm]	2208
[mm]	[mm]	[mm]	[mm]	2208...	2208...	2208...	2208...	2208...	2208...	[kg/m]
300	227	52.5	80	.052.063/300	.052.063/300	.052.075/300	.052.100/300	.052.125/300	.052.150/300	≈ 1.20
300	217	62.5	90	-	-	.062.075/300	.062.100/300	.062.125/300	.062.150/300	≈ 1.24
300	205	74.5	102	-	-	-	.074.100/300	.074.125/300	.074.150/300	≈ 1.29
300	192	87.5	115	-	-	-	.087.100/300	.087.125/300	.087.150/300	≈ 1.35
300	167	112.5	140	-	-	-	-	.112.125/300	.112.150/300	≈ 1.46

\*twisterchain classic (1<sup>st</sup> generation),

R	055	063	075	100	125	150	Pitch [mm/link]	44
K	265	290	330	410	485	565	Links/m	23
							corresponds to [mm]	1,012



Combined spiral and circular movement - igus® twisterchain classic (1<sup>st</sup> generation)

Dimensions

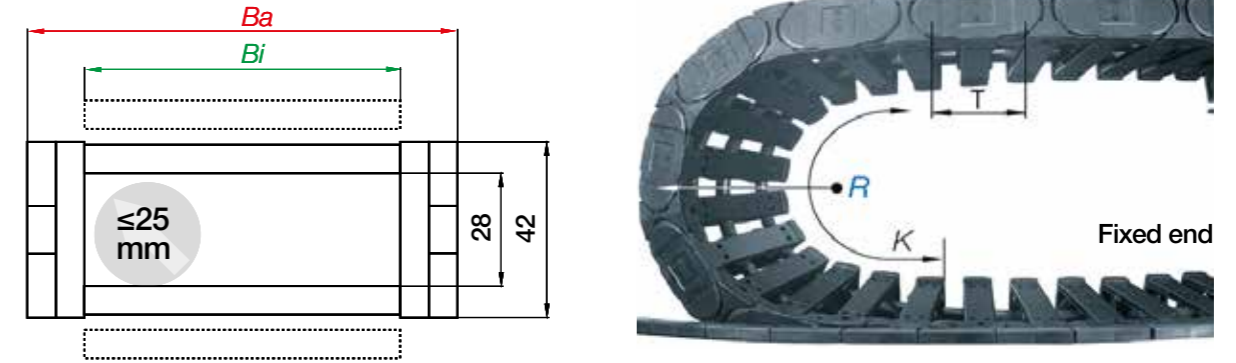

Series 2208 | interior separation

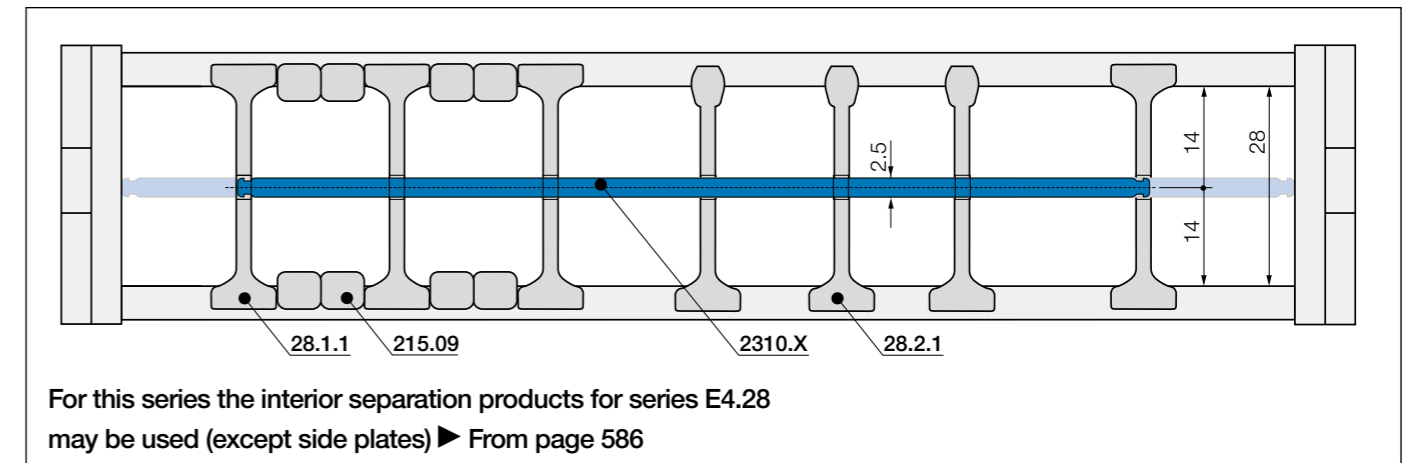

- i** AR = Outer radius of e-chain®
- IR = Inner radius e-chain®
- R = Bend radius e-chain®
- X<sub>1</sub> = Inner machine limit
- X<sub>2</sub> = Outer machine limit
- A1 = Intermediate link position
- H = Nominal clearance height
- K = Add-on for bend radius
- T = Pitch

Series TC32 | Crossbars removable along the inner and outer radius

AR	Bi	Ba	X <sub>2</sub>	X <sub>1</sub>	R 100 [mm]	R 125 [mm]	R 150 [mm]	R 175 [mm]	R 200 [mm]	R 250 [mm]	TC32
[mm]	[mm]	[mm]	[mm]	[mm]	TC32...	TC32...	TC32...	TC32...	TC32...	TC32...	[kg/m]
400	87.5	108.5	480	270	087.100/400	087.125/400	087.150/400	087.175/400	087.200/400	087.250/400	≈ 1.82
400	100	121	480	250	-	-	10.150/400	10.175/400	10.200/400	10.250/400	≈ 1.90
400	108	129	480	250	-	-	-	11.175/400	11.200/400	11.250/400	≈ 1.95
400	125	146	480	220	-	-	-	12.175/400	12.200/400	12.250/400	≈ 2.05
400	137.5	158.5	480	210	-	-	-	-	-	137.250/400	≈ 2.13
400	150	171	480	200	-	-	-	-	-	15.250/400	≈ 2.21
500	100	121	580	350	10.100/500	10.125/500	10.150/500	10.175/500	10.200/500	10.250/500	≈ 1.90
500	108	129	580	350	-	11.125/500	11.150/500	11.175/500	11.200/500	11.250/500	≈ 1.95
500	125	146	580	320	-	12.125/500	12.150/500	12.175/500	12.200/500	12.250/500	≈ 2.05
500	137.5	158.5	580	310	-	-	137.150/500	137.175/500	137.200/500	137.250/500	≈ 2.13
500	150	171	580	300	-	-	15.150/500	15.175/500	15.200/500	15.250/500	≈ 2.21
600	108	129	680	450	11.100/600	11.125/600	11.150/600	-	-	-	≈ 1.95
600	125	146	680	420	-	12.125/600	12.150/600	12.175/600	12.200/600	12.250/600	≈ 2.05
600	137.5	158.5	680	410	-	137.125/600	137.150/600	137.175/600	137.200/600	137.250/600	≈ 2.13
600	150	171	680	400	-	-	15.150/600	15.175/600	15.200/600	15.250/600	≈ 2.21

R	100	125	150	175	200	250	Pitch [mm/link]	56
H +20°	254	304	354	404	454	554	Links/m	18
K	465	550	620	700	780	940	corresponds to [mm]	1,008



twisterchain 2<sup>nd</sup> generation from igus® - successfully tested for over 1 million cycles in the igus® laboratory

Dimension A1 dependent on outer radius AR

AR	R 100	R 125	R 150	R 175	R 200	R 250
[mm]	A1 [mm]	A1 [mm]	A1 [mm]	A1 [mm]	A1 [mm]	A1 [mm]
400	51	51	52	53	53	58
500	65	65	66	67	69	71
600	79	80	81	81	82	85

Dimension A1 always with tolerance of ± 2.5mm

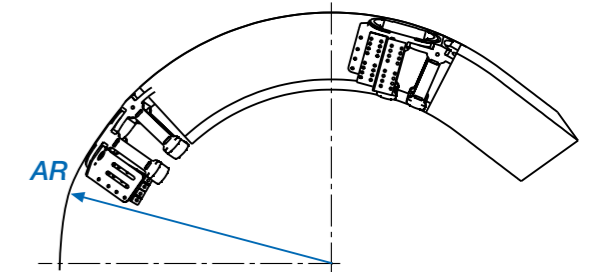

Note: outer radius AR (see drawing) determines dimension A1!



Intermediate link

The cable-friendly intermediate link increases the strength and stability of twisterchain many times over. It also serves as interior separation, dividing the filling space into two chambers. Outer radius AR determines dimension A1.

Dimensions

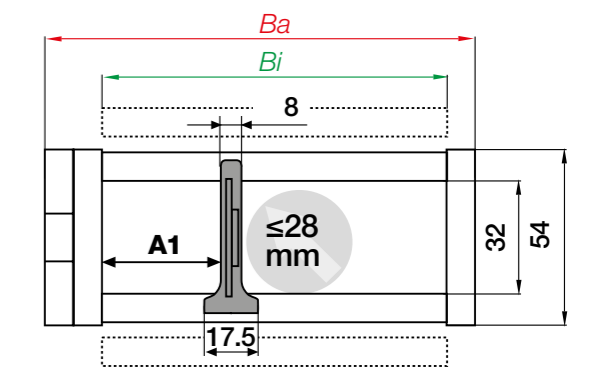

Series TC32 | Interior separation

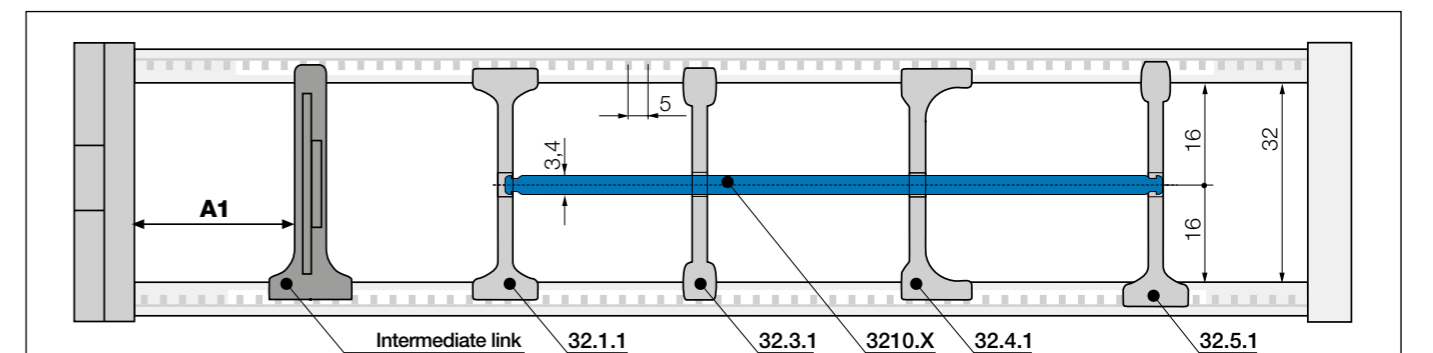

For this series the interior separation products for series E4.32 may be used (except side plates) ▶ From page 594

- i** AR = Outer radius of e-chain®
- IR = Inner radius e-chain®
- R = Bend radius e-chain®
- X<sub>1</sub> = Inner machine limit
- X<sub>2</sub> = Outer machine limit
- A1 = Intermediate link position
- H = Nominal clearance height
- K = Add-on for bend radius
- T = Pitch





Series TC56 | Crossbars removable along the inner and outer radius

AR	Bi	Ba	X <sub>2</sub>	X <sub>1</sub>	R 150 [mm]	R 200 [mm]	R 250 [mm]	R 300 [mm]	R 400 [mm]	TC56
[mm]	[mm]	[mm]	[mm]	[mm]	TC56...	TC56...	TC56...	TC56...	TC56...	[kg/m]
650	125	155	730	470	12.150/650	12.200/650	12.250/650	12.300/650	-	≈ 3.45
650	137.5	168	730	460	-	13.200/650	13.250/650	13.300/650	13.400/650	≈ 3.54
650	150	180	730	450	-	-	15.250/650	15.300/650	15.400/650	≈ 3.62
650	162.5	193	730	440	-	-	16.250/650	16.300/650	16.400/650	≈ 3.70
650	175	205	730	430	-	-	-	17.300/650	17.400/650	≈ 3.78
650	187.5	218	730	420	-	-	-	18.300/650	18.400/650	≈ 3.87
650	200	230	730	400	-	-	-	-	20.400/650	≈ 3.95
750	137.5	168	830	560	13.150/750	13.200/750	13.250/750	13.300/750	-	≈ 3.54
750	150	180	830	550	-	15.200/750	15.250/750	15.300/750	15.400/750	≈ 3.62
750	162.5	193	830	540	-	16.200/750	16.250/750	16.300/750	16.400/750	≈ 3.70
750	175	205	830	530	-	-	17.250/750	17.300/750	17.400/750	≈ 3.78
750	187.5	218	830	520	-	-	18.250/750	18.300/750	18.400/750	≈ 3.87
750	200	230	830	500	-	-	20.250/750	20.300/750	20.400/750	≈ 3.95
850	150	180	930	650	15.150/850	15.200/850	15.250/850	15.300/850	15.400/850	≈ 3.62
850	162.5	193	930	640	16.150/850	16.200/850	16.250/850	16.300/850	16.400/850	≈ 3.70
850	175	205	930	630	17.150/850	17.200/850	17.250/850	17.300/850	17.400/850	≈ 3.78
850	187.5	218	930	620	-	18.200/850	18.250/850	18.300/850	18.400/850	≈ 3.87
850	200	230	930	600	-	-	20.250/850	20.300/850	20.400/850	≈ 3.95

R	150	200	250	300	400	Pitch [mm/link]	91
H <sub>+25</sub>	384	484	584	684	884	Links/m	11
K	750	900	1,050	1,225	1,450	corresponds to [mm]	1,001



twisterchain in a guide trough type 01 for rotary movement on an articulated robot - long service life and robust: tested successfully for more than 1,000,000 cycles



Dimension A1 dependent on outer radius AR

AR	R 150	R 200	R 250	R 300	R 400
[mm]	A1 [mm]	A1 [mm]	A1 [mm]	A1 [mm]	A1 [mm]
650	83	85	88	90	97
750	98	101	102	103	110
850	113	116	117	118	124

Dimension A1 always with tolerance of ± 2.5mm

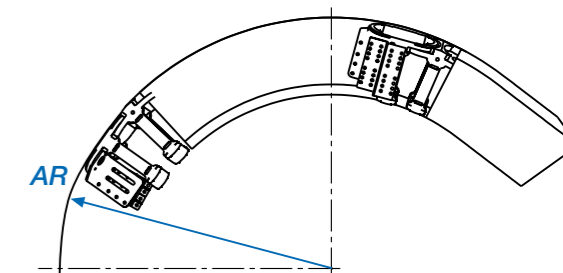

Note: outer radius AR (see drawing) determines dimension A1!



Intermediate link

The cable-friendly intermediate link increases the strength and stability of twisterchain many times over. It also serves as interior separation, dividing the filling space into two chambers. Outer radius AR determines dimension A1.

Dimensions

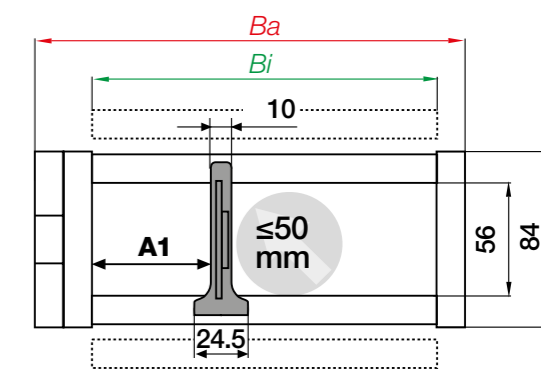

Series TC56 | Interior separation

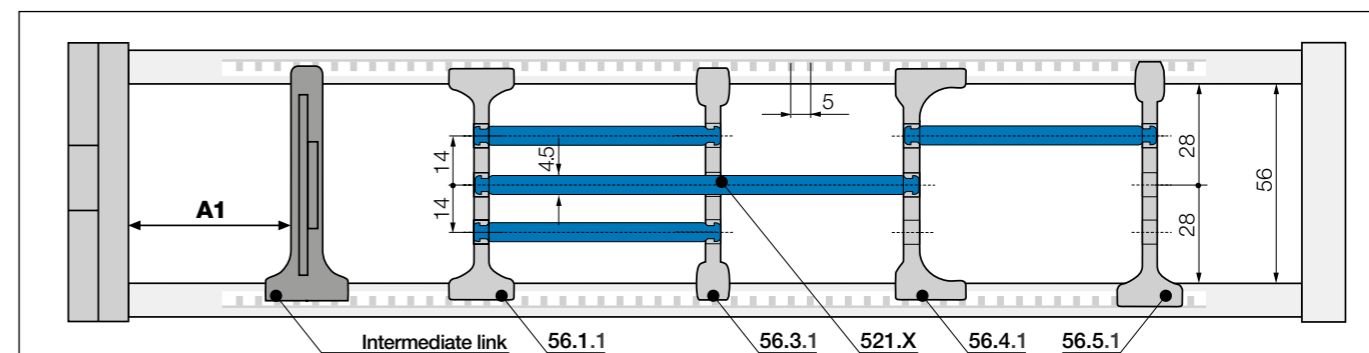

For this series the interior separation products for series E4.56 may be used (except side plates) ▶ From page 616

- i** AR = Outer radius of e-chain®
- IR = Inner radius e-chain®
- R = Bend radius e-chain®
- X<sub>1</sub> = Inner machine limit
- X<sub>2</sub> = Outer machine limit
- A1 = Intermediate link position
- H = Nominal clearance height
- K = Add-on for bend radius
- T = Pitch

Steel mounting bracket for twisterchain (2<sup>nd</sup> generation)

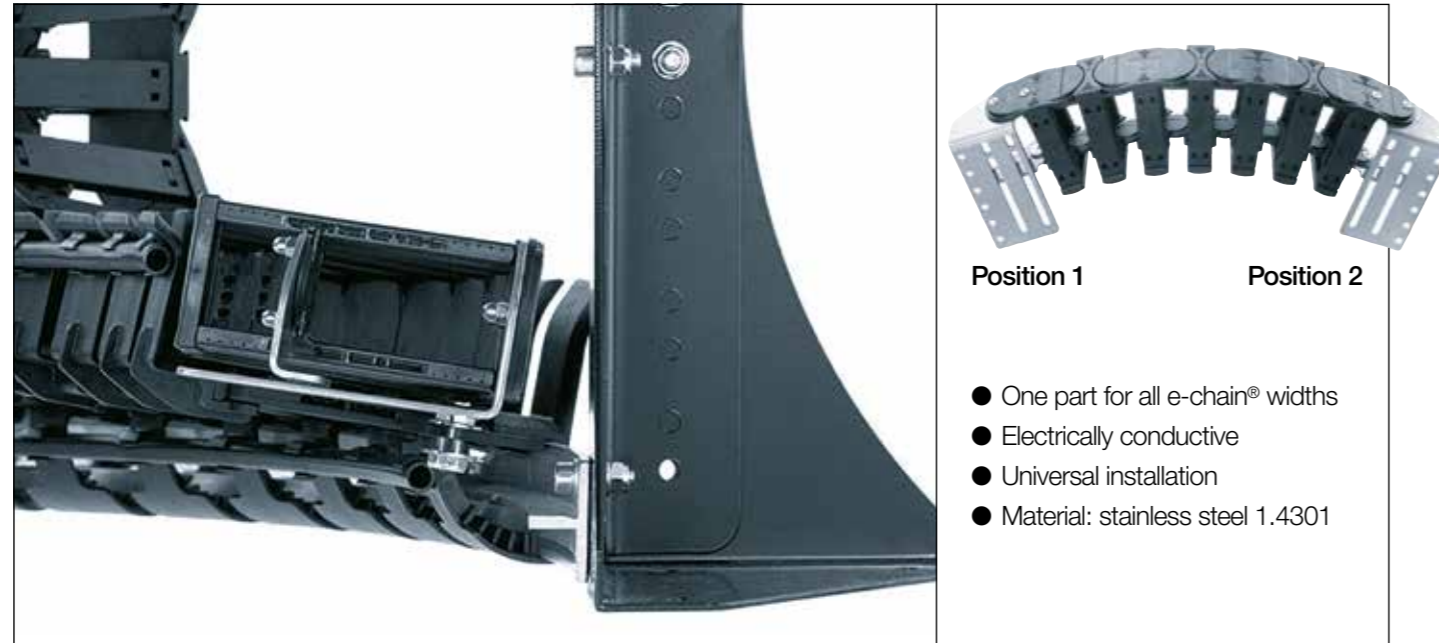

Steel, one-piece design for twisterchain (2<sup>nd</sup> generation) | Recommended for unsupported and circular applications

For series	Part No. full set	Part No. position 1	Part No. position 2
TC32 ▶	TC3200.34.VS.E	TC3200.30.VS.E	TC3200.40.VS.E
TC42 ▶	TC4200.34.VS.E	TC4200.30.VS.E	TC4200.40.VS.E
TC56 ▶	TC5600.34.VS.E	TC5600.30.VS.E	TC5600.40.VS.E

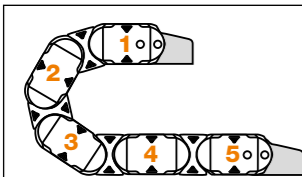

**Note:** twisterchain e-chains® must always start and end on an outer side-link. Please note when calculating!

**TC3200.34.VS.E** Order example

- Stainless steel (standard)
- Standard: bolted
- Full set
- Series

Steel mounting bracket for twisterchain classic (1<sup>st</sup> generation)

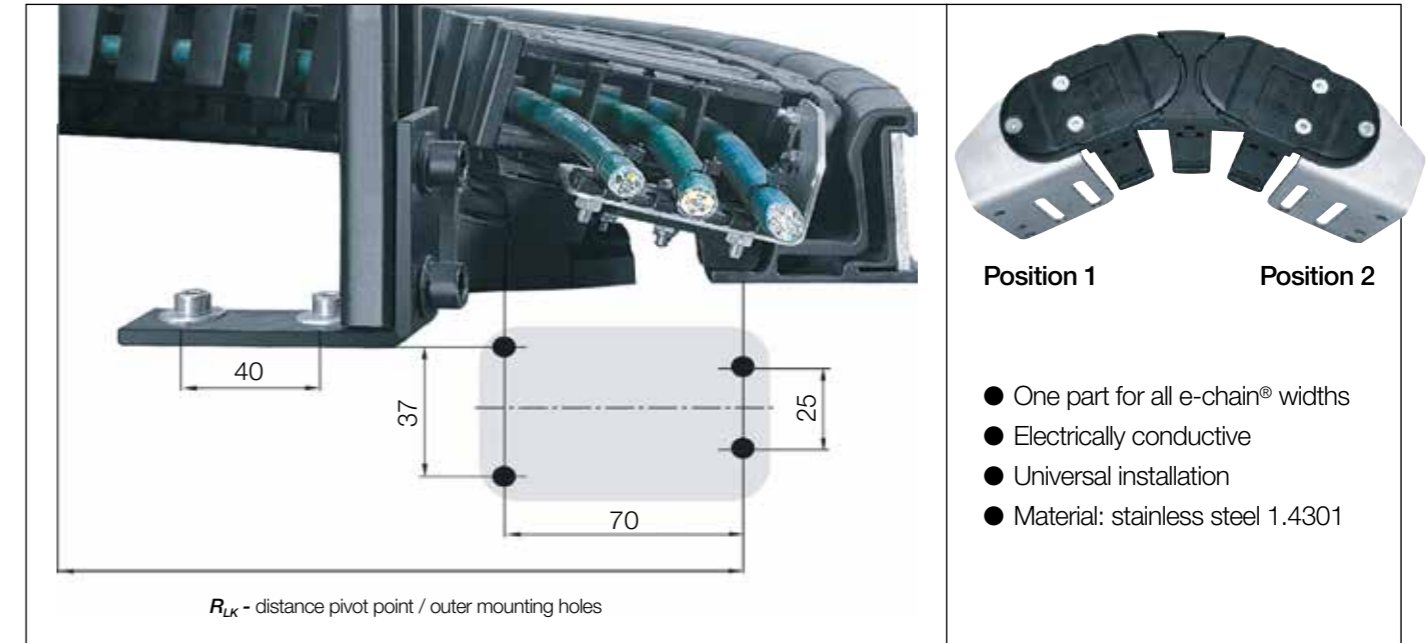

Steel, one-piece design for twisterchain (1<sup>st</sup> generation) | Recommended for unsupported and circular applications

For series	Part No. full set	Part No. position 1	Part No. position 2
2208 ▶	22080.34.VS.E	22080.30.VS.E	22080.40.VS.E

The guide trough is attached to the fixed end of the twisterchain classic based on the drill pattern shown in the diagram above

The following bolted connections are permitted: ● Plain holes: 4 x Ø 6.6 - 7mm ● Mounting only with bolts: 4 x bolts M6

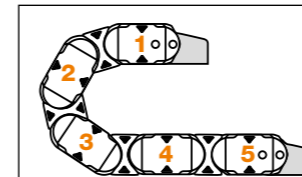

**Note:** twisterchain e-chains® must always start and end on an outer side-link. Please note when calculating!

**22080.34.VS.E** Order example

- Stainless steel (standard)
- Standard: bolted
- Full set
- Series

# Save installation time and cost - better guidance for circular movement - increase service life!

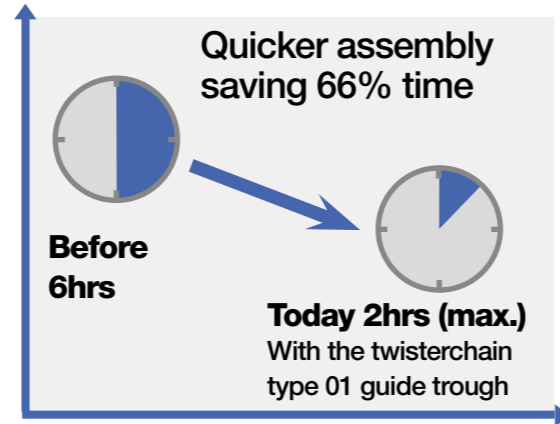
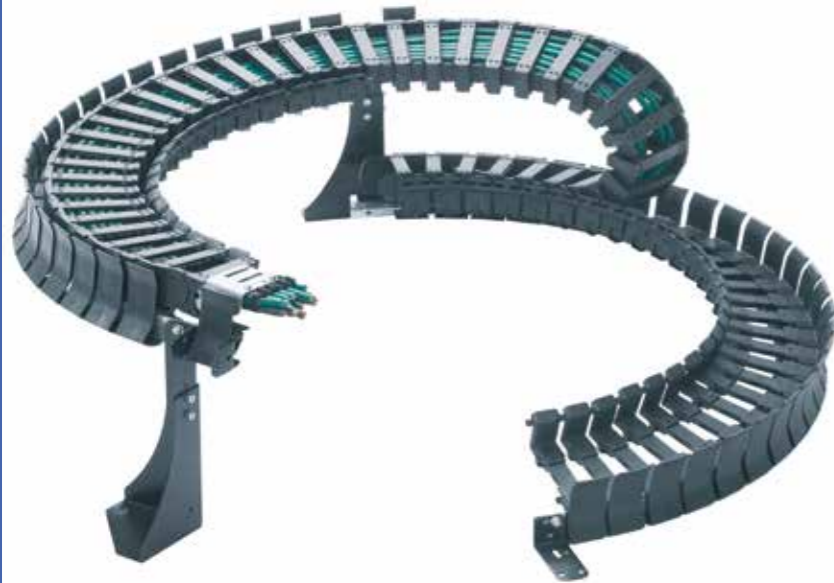

**i** Guide trough type 02 for series 2208 ▶ From page 986

With the twisterchain trough type 01, complex adjustment work is reduced and so assembly time is reduced from 6 hours to 2 hours. It also reduces noise, whilst travel speed and service life can be increased, thanks to its nearly all-plastic design. Available for all twisterchains from the new and original product range.

- Suitable for high dynamics, because of the full guidance of the upper run
- Much smoother and quieter motion in the trough due to continuous guidance of the upper run
- Upper run guided in the polymer trough over the full length
- Preassembled delivery possible
- Easy adjustment, alignment and handling
- Assembly time reduced from 6 hours to 2 hours

## twisterchain type 01 guide trough options



**9XXX.31**  
Complete trough  
(with base support, height adjustment and attachment angle brackets)

**9XXX.32**  
Upper and lower run trough  
(without floor support and height adjustment)  
Special option: customer supplies base supports

**9XXX.30**  
Lower run trough  
(with mounting angle brackets)  
Special option: customer builds upper run trough

## Product range | twisterchain guide trough type 01

Part No. series	Outer radius AR [mm]	Angle of rotation min.-max. α	Part No. complete trough	Part No. upper/lower run trough	Part No. lower run trough	
TC32 / TC42	400	0 - 90°	9XXX.31.90.400/Bi.R	9XXX.32.90.400/Bi.R	9XXX.30.90.400/Bi.R	
		90° - 180°	9XXX.31.180.400/Bi.R	9XXX.32.180.400/Bi.R	9XXX.30.180.400/Bi.R	
		180° - 270°	9XXX.31.270.400/Bi.R	9XXX.32.270.400/Bi.R	9XXX.30.270.400/Bi.R	
		270° - 360°	9XXX.31.360.400/Bi.R	9XXX.32.360.400/Bi.R	9XXX.30.360.400/Bi.R	
	500	0 - 90°	9XXX.31.90.500/Bi.R	9XXX.32.90.500/Bi.R	9XXX.30.90.500/Bi.R	
		90° - 180°	9XXX.31.180.500/Bi.R	9XXX.32.180.500/Bi.R	9XXX.30.180.500/Bi.R	
		180° - 270°	9XXX.31.270.500/Bi.R	9XXX.32.270.500/Bi.R	9XXX.30.270.500/Bi.R	
		270° - 360°	9XXX.31.360.500/Bi.R	9XXX.32.360.500/Bi.R	9XXX.30.360.500/Bi.R	
	600	0 - 90°	9XXX.31.90.600/Bi.R	9XXX.32.90.600/Bi.R	9XXX.30.90.600/Bi.R	
		90° - 180°	9XXX.31.180.600/Bi.R	9XXX.32.180.600/Bi.R	9XXX.30.180.600/Bi.R	
		180° - 270°	9XXX.31.270.600/Bi.R	9XXX.32.270.600/Bi.R	9XXX.30.270.600/Bi.R	
		270° - 360°	9XXX.31.360.600/Bi.R	9XXX.32.360.600/Bi.R	9XXX.30.360.600/Bi.R	
TC42 / TC56	650	0 - 90°	9XXX.31.90.650/Bi.R	9XXX.32.90.650/Bi.R	9XXX.30.90.650/Bi.R	
		90° - 180°	9XXX.31.180.650/Bi.R	9XXX.32.180.650/Bi.R	9XXX.30.180.650/Bi.R	
		180° - 270°	9XXX.31.270.650/Bi.R	9XXX.32.270.650/Bi.R	9XXX.30.270.650/Bi.R	
	750	270° - 360°	9XXX.31.360.650/Bi.R	9XXX.32.360.650/Bi.R	9XXX.30.360.650/Bi.R	
		0 - 90°	9XXX.31.90.750/Bi.R	9XXX.32.90.750/Bi.R	9XXX.30.90.750/Bi.R	
		90° - 180°	9XXX.31.180.750/Bi.R	9XXX.32.180.750/Bi.R	9XXX.30.180.750/Bi.R	
	850	180° - 270°	9XXX.31.270.750/Bi.R	9XXX.32.270.750/Bi.R	9XXX.30.270.750/Bi.R	
		270° - 360°	9XXX.31.360.750/Bi.R	9XXX.32.360.750/Bi.R	9XXX.30.360.750/Bi.R	
		0 - 90°	9XXX.31.90.850/Bi.R	9XXX.32.90.850/Bi.R	9XXX.30.90.850/Bi.R	
			90° - 180°	9XXX.31.180.850/Bi.R	9XXX.32.180.850/Bi.R	9XXX.30.180.850/Bi.R
			180° - 270°	9XXX.31.270.850/Bi.R	9XXX.32.270.850/Bi.R	9XXX.30.270.850/Bi.R
			270° - 360°	9XXX.31.360.850/Bi.R	9XXX.32.360.850/Bi.R	9XXX.30.360.850/Bi.R

Complete Part No. **9XXX** with required series (TC32, TC42, TC56), value **Bi** and required bend radius **R** ▶ **9TC32.31.180.600/06.250**  
For series 2208 please use guide troughs type 02 ▶ Page 986

**9TC32.31.180.600/12.250**

**9XXXX.31.180.600/Bi. R**

**Order key**  
Guide trough type 01

- R** - Bend radius, please add required value
- Bi** - width index, please add required value
- Outer radius of e-chain®
- Angle of rotation of application (90°, 180°, 270°, 360°)
- Trough version
- Guide trough of selected series

### More order examples

Complete trough	Part No. <b>9TC32.31.180.600/12.250</b>
Lower run trough only	Part No. <b>9TC32.30.180.600/12.250</b>
Upper and lower run trough without base support	Part No. <b>9TC32.32.180.600/12.250</b>

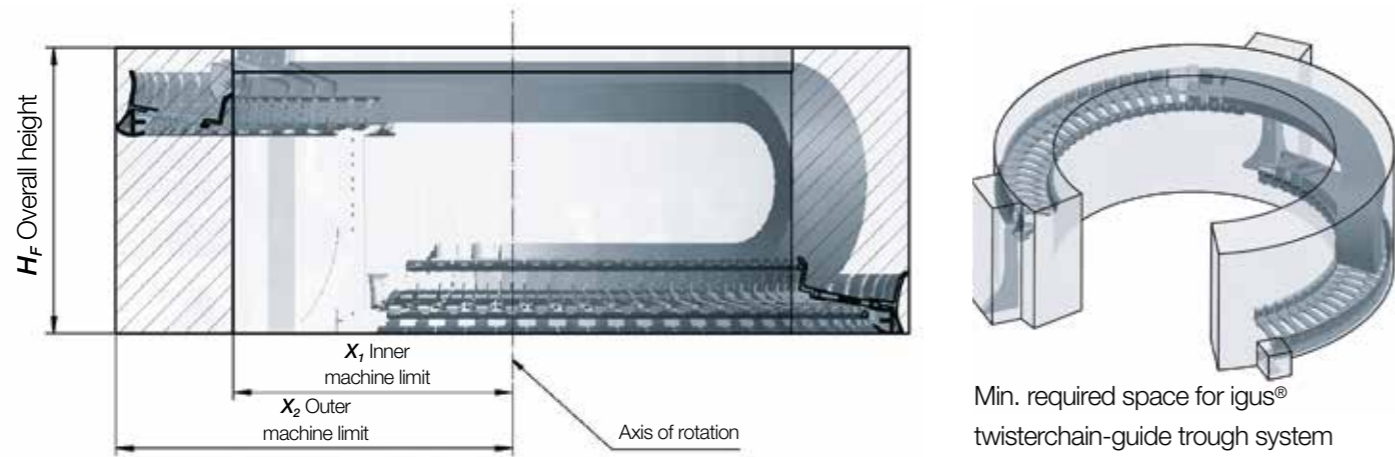

Installation dimensions |  $X_1$  inner machine limit and  $X_2$  outer machine limit

AR [mm]	$X_2$ [mm]	$X_1$ depending on Bi [mm]												
		87.5	100	108	125	137.5	150	162.5	168	175	187.5	200		
<b>TC32</b>														
400	480	270	250	250	220	210	200							
500	580	-	350	350	320	310	300							
600	680	-	-	450	420	410	400							
<b>TC42</b>														
400	480	270	250	250	220	210	200	190	190	180	-	-		
500	580	-	350	350	320	310	300	290	290	280	280	250		
600	680	-	-	450	420	410	400	390	390	380	380	350		
650	730	-	-	-	470	460	450	440	440	430	420	400		
750	830	-	-	-	-	560	550	540	540	530	520	500		
850	930	-	-	-	-	-	650	640	640	630	620	600		
<b>TC56</b>														
650	730	-	-	-	470	460	450	440	-	430	420	400		
750	830	-	-	-	-	560	550	540	-	530	520	500		
850	930	-	-	-	-	-	650	640	-	630	620	600		

For series 2208 please use guide troughs type 02 ▶ Page 986

Construction height |  $H_F$  depending on bend radius of twisterchain guide trough

Part No. series	R [mm]	100	125	150	175	200	250	300	400
		$H_F$ Installation height [mm]							
TC32		370	420	470	520	570	670	-	-
TC42		380	430	480	530	580	680	-	-
TC56		-	-	500	-	600	700	800	1,000

Angle of rotation for 360° |  $W_2$  angle of upper run twisterchain guide trough

Part No. series	AR [mm]	R [mm]	100	125	150	175	200	250	300	400
			$W_2$ angle of rotation							
TC32/TC42	400		90°	90°	90°	90°	90°	90°	90°	90°
TC32/TC42	500		90°	90°	90°	90°	90°	90°	90°	90°
TC32/TC42	600		135°	135°	135°	135°	90°	90°	90°	90°
TC42/TC56	650		135°	135°	135°	135°	90°	90°	90°	90°
TC42/TC56	750		135°	135°	135°	135°	135°	135°	90°	90°
TC42/TC56	850		135°	135°	135°	135°	135°	135°	135°	135°

Support for the upper run as of 180° rotation angle

Angle of rotation |  $W_1$  |  $W_{total}$

Angle of rotation of system	Angle of lower run
$W_{ges.}$	$W_1$
90°	45°
180°	90°
270°	135°
360°	180°

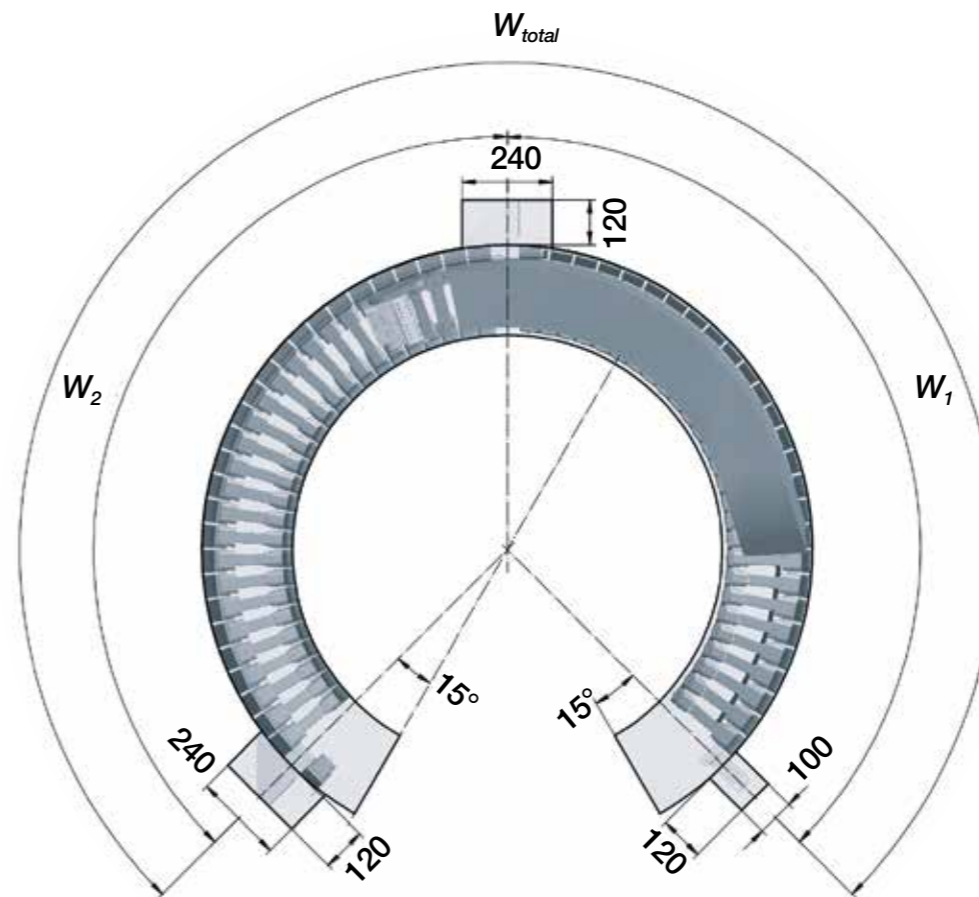

**i** AR = Outer radius of e-chain®  
 IR = Inner radius e-chain®  
 R = Bend radius e-chain®  
 $X_1$  = Inner machine limit  
 $X_2$  = Outer machine limit  
 $H_F$  = Total trough height  
 $H_F$  = e-chain® height incl. 50mm clearance  
 $H$  = e-chain® height  
 $K$  = Add-on for bend radius  
 $W_1$  = Angle of upper run  
 $W_2$  = Angle of lower run  
 $W_{total}$  = Angle of rotation of system

# Type 02 guide trough for twisterchain classic (1<sup>st</sup> generation) series 2208

- Support for the upper run and guidance of twisterchain classic series 2208
- Angle of rotation up to 360° possible, 400° upon request
- The modular design of the guide trough makes it possible to connect a large number of e-chains® radii, circle and bend radii by using the same trough sections
- If the e-chain® radius changes, the trough can simply be adapted without purchasing a completely new trough
- The specified part number shown below includes the complete trough system



## Product range | Guide trough type 02 for twisterchain classic (1<sup>st</sup> generation)

Part No. series	Outer radius AR [mm]	Angle of rotation min.-max. α	Part No. guide trough type 02	Part No. guide trough with bottom support	Number of supports
2208	300	45° - 100°	92208.4.45.300/ Bi.R	not necessary	-
	300	>100° - 180°	92208.4.90.300/ Bi.R	not necessary	-
	300	>180° - 270°	92208.4.135.300/ Bi.R*	92208.5.135.300/ Bi.R	1
	300	>270° - 360°	92208.4.180.300/ Bi.R**	92208.5.180.300/ Bi.R	2

\* These troughs feature one support for the upper run / \*\* These troughs feature two supports for the upper run

Complete Part No. with the required Bi and bend radius R e.g. 92208.5.180.600/112.150

### 92208.5.180.600/112.150



#### Order key Guide trough type 02

- R - Bend radius, please add required value
- Bi - width index, please add required value
- Outer radius of e-chain®
- Trough angle (Standard 180°, 135°, 90°, 45°)
- Trough version (.5. with and .4. without bottom support)
- Guide trough - series 2208

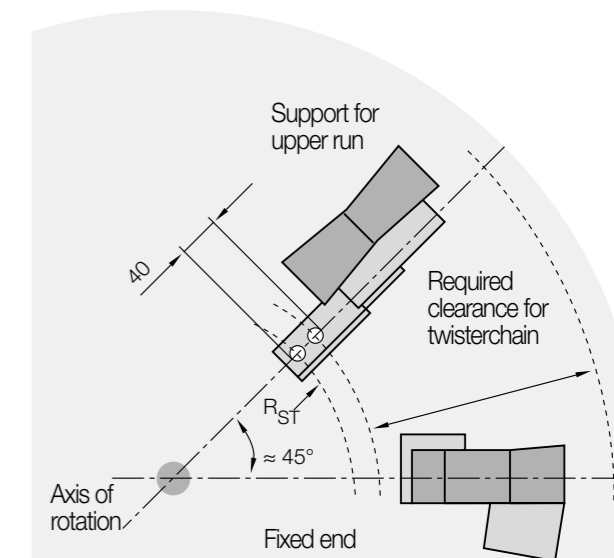
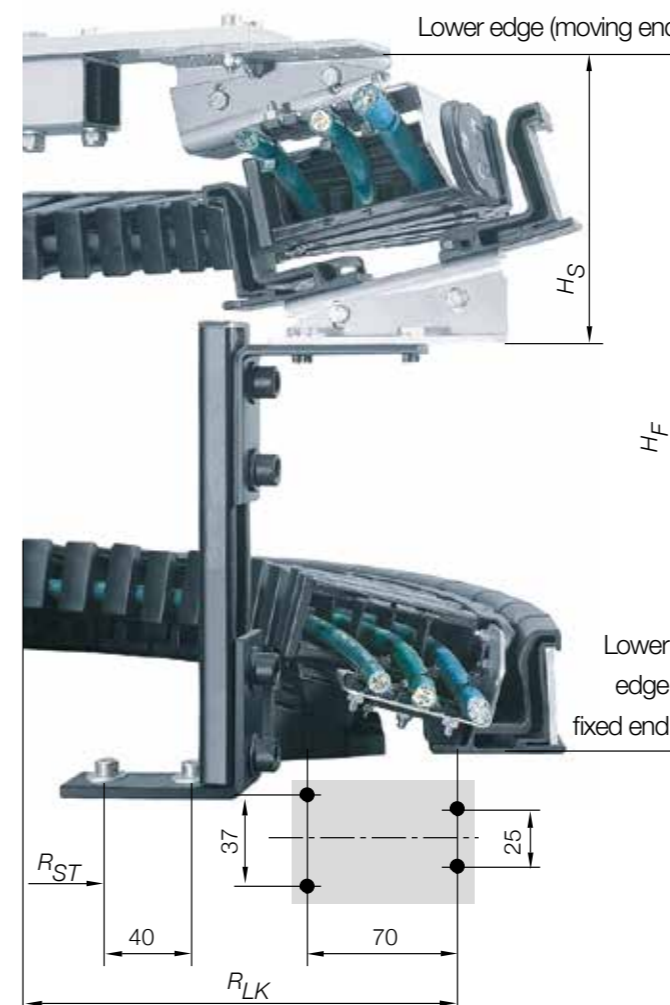

Mounting position for one support

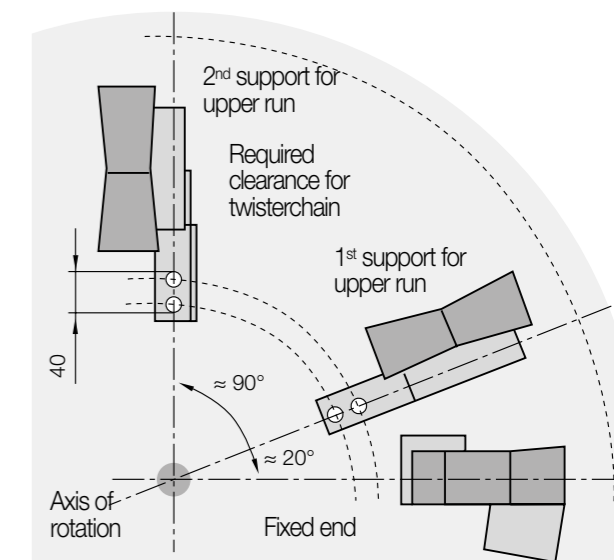

Mounting position for two supports

The guide trough must be mounted at the fixed end of the twisterchain using the drilling template shown. The following screw connections are allowed:

- Bore hole: 4 x Ø 6.6 - 7mm
- Mounting only with bolts: 4 x bolt M6

## Installation dimensions | Guide trough type 02 (1<sup>st</sup> generation)

Part No. series	RLK [mm]	Hs [mm]	Part No. guide trough	RST [mm]	R [mm]	055	063	075	100	125	150
2208...	265	130	92208...	145		195	211	235	285	335	385





# twisterband

Up to 7,000°\* rotary movement in the smallest spaces



#### twisterband advantages:

- Rotary movements up to 7,000°\*
- Rotary speeds up to 180°/s possible
- Openable with film hinge or openable "easy" design
- HD version with strong pin and hook connection for an even longer service life
- Compact, modular and lightweight
- Bands can be lengthened and shortened as required
- Minimum installation space, fits very closely around the rotary axis
- Cost-effective and easy to fill



#### When to use another igus® solution:

- For applications with a high fill weight
  - ▶ **twisterchain system, from page 966**
- For applications with multi-axis movements
  - ▶ **triflex® R, from page 866**
- **RBR** versions with a high fill weight
  - ▶ **Designing, page 126**
- If a lubrication and maintenance-free slewing ring bearing for "endless" rotation is required
  - ▶ **iglidur® slewing ring bearings, [www.igus.eu/PRT](http://www.igus.eu/PRT)**
- If shielded cables are necessary
  - ▶ **Please contact us**

\*Depending on installation orientation - vertical: up to 3,000°, horizontal: 7,000° and more possible



## Up to 7,000°\* rotary movement in the smallest spaces - twisterband

With the compact igus® twisterband, rotations of up to 7,000°\* can be achieved cost-effectively, even in confined spaces. Energy, data and media are securely guided.

- Rotary movements up to 7,000°\*
- Rotary speeds up to 180°/s possible
- Openable with film hinge or openable "easy" design
- HD version with strong pin and hook connection for an even longer service life
- Compact, modular and lightweight
- Bands can be lengthened and shortened as required
- Minimum installation space, fits very closely around the rotary axis
- Cost-effective and easy to fill

### Typical industries and applications

- Cable reels
- Robots (robot arms, axis1/6, SCARA robots)
- Machine tools
- Medical equipment
- Radar and telescope equipment
- Aerospace, test, measurement, handling, lifting and installation equipment
- Wind turbines (e.g. blade adjustment)
- Wherever rotary unions or slip rings are used

\*Depending on installation orientation - vertical: up to 3,000°, horizontal: 7,000° and more possible

Series	Inner height <i>hi</i> [mm]	Inner width <i>Bi</i> [mm]	Ø <i>X</i> <sub>1</sub> [mm]	Ø <i>X</i> <sub>2</sub> [mm]	≥ <i>R</i> [mm]	≤ <i>R</i> [mm]	≤ <i>d1</i> [mm]	Interior separation	Opening principle	Page
--------	--------------------------------	-------------------------------	---------------------------------	---------------------------------	--------------------	--------------------	---------------------	---------------------	-------------------	------

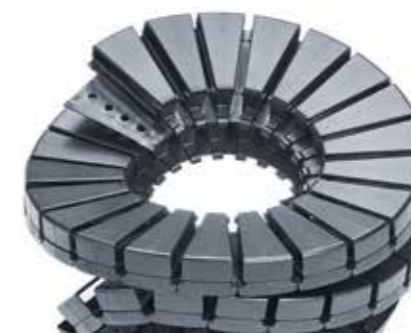

### twisterband

e-chain® links on a strip.  
Openable with film hinge  
or openable "easy" design

TB12.23.9	9	23	40	140	024	035	7	–	"easy" design	994
TB20.44.12	12	44	50	220	034	057	9	–	"easy" design	994
TB20.44.18	18	44	50	220	034	057	14	yes	lock	994
TB29.27.22	22	27	200	320	069	082	17	yes	lock	994
TB30.75.22	22	75	90	330	044	077	17	yes	lock	994



### twisterband HD

e-chain® links with strong pin  
and hook connection.  
Openable with film-hinge

TBHD30.75.22	22	75	90	330	044	077	17	yes	lock	998
TBHD42.135.30 <small>New</small>	30	135	90	500	056	119	20	yes	lock	998

Other sizes available upon request. *X*<sub>1</sub> = inner machine limit *X*<sub>2</sub> = outer machine limit



Available from stock. Ready to ship in 24 - 48hrs.\*

\*The delivery times indicated correspond to the average time until the ordered goods are dispatched.



*Bi* = Inner width e-chain®  
*hi* = Inner height e-chain®

*X*<sub>1</sub> = Inner machine limit  
*X*<sub>2</sub> = Outer machine limit

≥ *R* = Minimum bend radius e-chain®  
≤ *R* = Max. bend radius e-chain®

*d1* = Max. cable diameter  
**XX** = Number of strips



A central shaft must be installed for horizontal orientation angles of rotation above 1,500°



Max. angle of rotation: as a rule of thumb: each segment gives 180° = 360° more rotation



Minimum installation space, fits very closely around the rotary axis



Film hinge: easy access and quick filling with cables and hoses



Compact, modular, cost-effective - up to 7,000° rotary movement\* in the most confined spaces

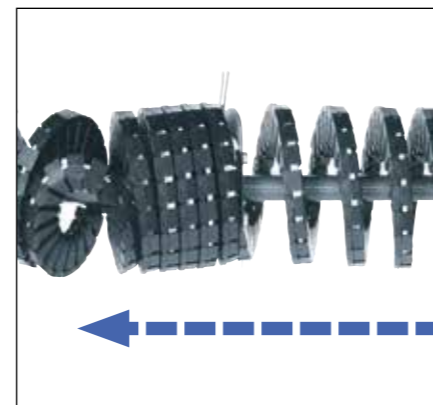

Can be reliably used in various installation positions (horizontal: 7,000° and more). Limited length compensation possible

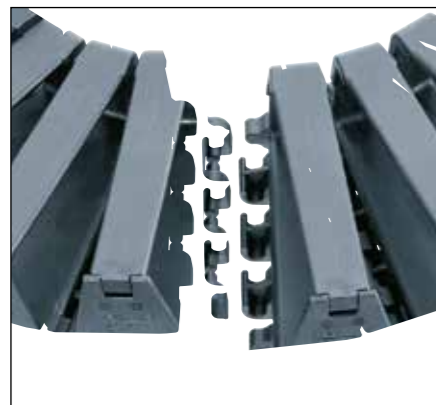

The twisterband HD is an advanced version of the standard twisterband ...



... instead of bands with integral hinges, the twisterband HD version is composed of separate e-chain® links with the pin/hook connecting system ...



... the advantage is a defined radius with higher strength.

Technical data

	Speed / acceleration*	180°/s
	twisterband - material - permitted temperature °C, igumid TE	0°C / +70°C
	twisterband HD - material - permitted temperature °C, igumid G	0°C / +80°C
	Flammability class, igumid G	VDE 0304 IIC UL94-HB
	Flammability class, igumid TE	VDE 0304 IIC UL94-HB

\*Speed / acceleration for TB29.27. upon request

Size overview

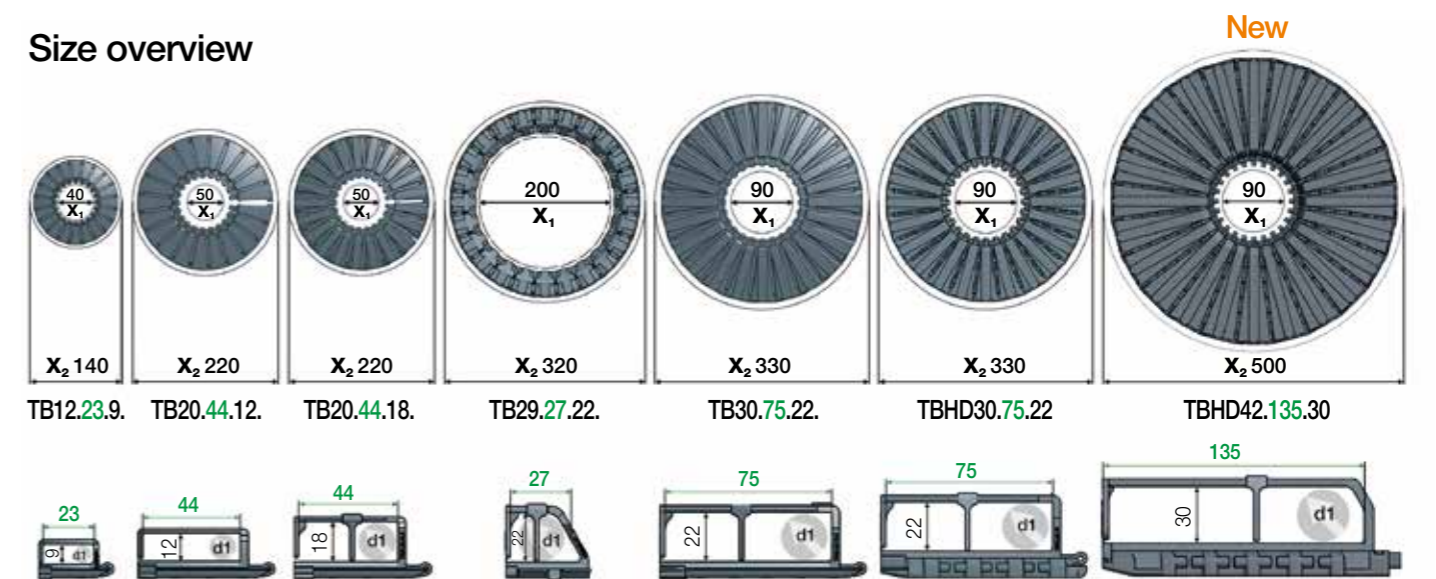

**i** Bi = Inner width e-chain® X<sub>1</sub> = Inner machine limit ≥ R = Minimum bend radius e-chain® d1 = Max. cable diameter  
 hi = Inner height e-chain® X<sub>2</sub> = Outer machine limit ≤ R = Max. bend radius e-chain® XX = Number of strips





Base plate with strain relief\*\*

Bands can be lengthened and shortened as required

4 sizes available

Some parts available with interior separation

Openable with film hinge or openable "easy" design

Base plate with strain relief\*\*

\*\*Base plates are delivered as standard as part of the twisterband module!

## Up to 7,000°\* rotary movement in the smallest spaces - twisterband

With the compact igus® twisterband rotations can be achieved cost-effectively and with low wear and low maintenance, even in a confined space. Energy, data and media are securely guided. Available in 5 sizes.

- Rotary movements up to 7,000°\*
- Rotary speeds up to 180°/s possible
- Compact, modular and lightweight
- Bands can be lengthened and shortened as required
- Minimum installation space, fits very closely around the rotary axis
- Can be reliably used in various installation positions (horizontal or vertical)
- Cost-effective
- Easy filling
- Ideal in combination with igus® chainflex® cables for rotary movements in very limited installation spaces

### Typical industries and applications

- Cable reels
- Robots (robot arms, axis1/6, SCARA robots)
- Machine tools
- Leisure rides
- Medical equipment
- Radar and telescope equipment
- Aerospace, test, measurement, handling, lifting and installation equipment
- Wind turbines (e.g. blade adjustment)
- Wherever rotary unions are used

\*Depending on installation orientation - vertical: up to 3,000°, horizontal: 7,000° and more possible



e-chain® links on a strip



twisterband | Openable with film hinge or with "easy" design

Part No.	Bi1	hi	X <sub>1</sub>	X <sub>2</sub>	≥ R	≤ R	≤ d1	Opening principle
twisterband	[mm]	[mm]	ø [mm]	ø [mm]	[mm]	[mm]	[mm]	
TB12. 23 .9. XX .01.0	23	9	40	140	24	35	7	"easy" design
TB20. 44 .12. XX .01.0	44	12	50	220	34	57	9	"easy" design
TB20. 44 .18. XX .01.0	44	18	50	220	34	57	14	lock
TB29. 27 .22. XX .01.0*	27	22	200	320	69	82	17	lock
TB30. 75 .22. XX .01.0	75	22	90	330	44	77	17	lock

More twisterband sizes upon request! **Note:** Series TB29.27.22. Rotary movement up to max. 720°

Base plates are delivered as standard as part of the twisterband module!

X<sub>1</sub> = ø inner machine installation space X<sub>2</sub> = ø outer machine installation space

Complete Part No. with required number of strips **XX**. Example: TB20.44.12.6.01.0

### Installation dimensions

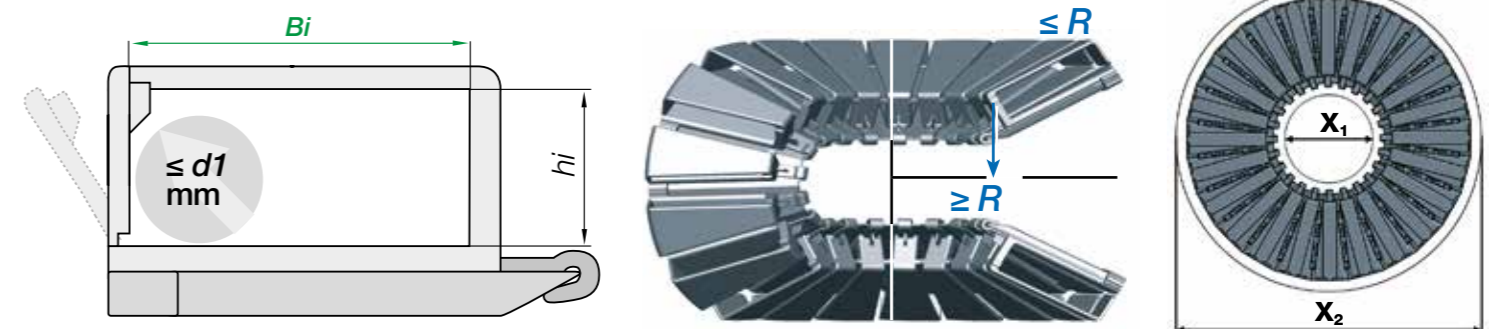

 Calculation: number of strips depends on angle of rotation (please always round up number of strips)

TB12:  $XX \approx \frac{XXXX^\circ}{360} + 2 =$  Example:  $XX \approx \frac{1200^\circ}{360} + 2 =$  Result:  $XX \approx 6$  strips

TB20:  $XX \approx \frac{XXXX^\circ}{340} + 2 =$  Example:  $XX \approx \frac{1200^\circ}{340} + 2 =$  Result:  $XX \approx 6$  strips

TB29:  $XX \approx \frac{XXXX^\circ}{180} + 2 =$  Example:  $XX \approx \frac{720^\circ}{180} + 2 =$  Result:  $XX \approx 6$  strips

TB30:  $XX \approx \frac{XXXX^\circ}{180} + 6 =$  Example:  $XX \approx \frac{1200^\circ}{180} + 6 =$  Result:  $XX \approx 13$  strips

XXXX° = Angle of rotation

 Available from stock. Ready to ship in 24 - 48hrs.\*

\*The delivery times indicated correspond to the average time until the ordered goods are dispatched.

Interior separation for twisterband

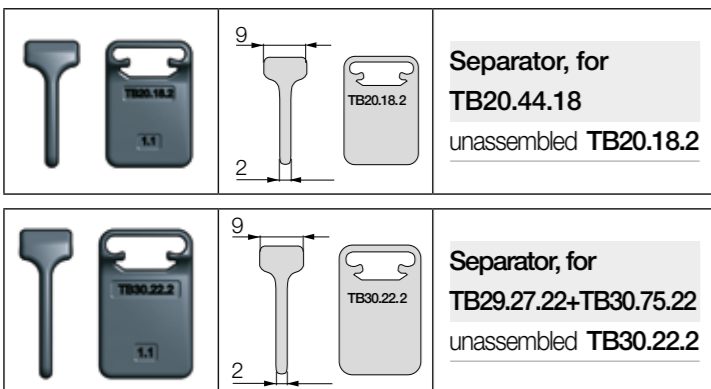
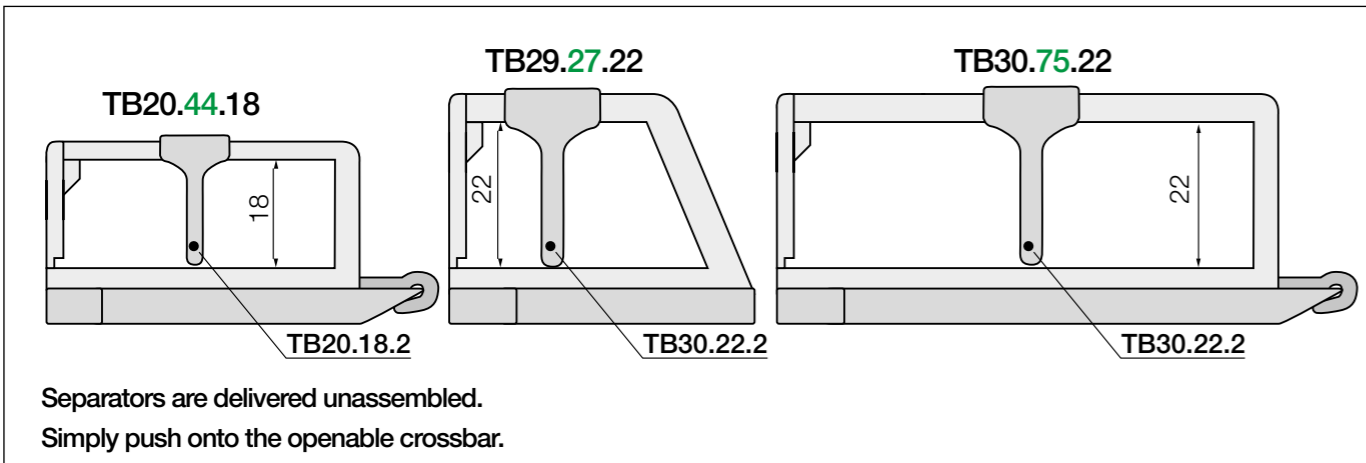

**Separators**  
To fit, simply open the e-chain®, insert a cable and press the separator onto the crossbar. Then add more cables. The separators provide a clear, cable-friendly interior separation.



Easy opening and filling of the twisterband with a click or with the "easy" design. Simply press separators on and add more cables. The separators provide a clear, cable-friendly interior separation.



igus® twisterband TB30 for circular movements up to 360°, E2 mini and E2/000 e-chains® are used in this loading and unloading unit

Base plates with strain relief for twisterband

Steel base plate dimensions for twisterband  
(for TB29.27.22 upon request)

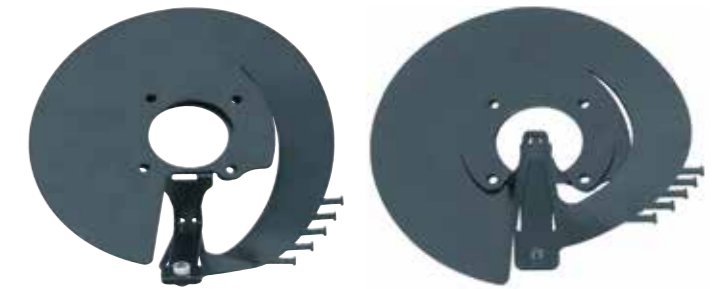
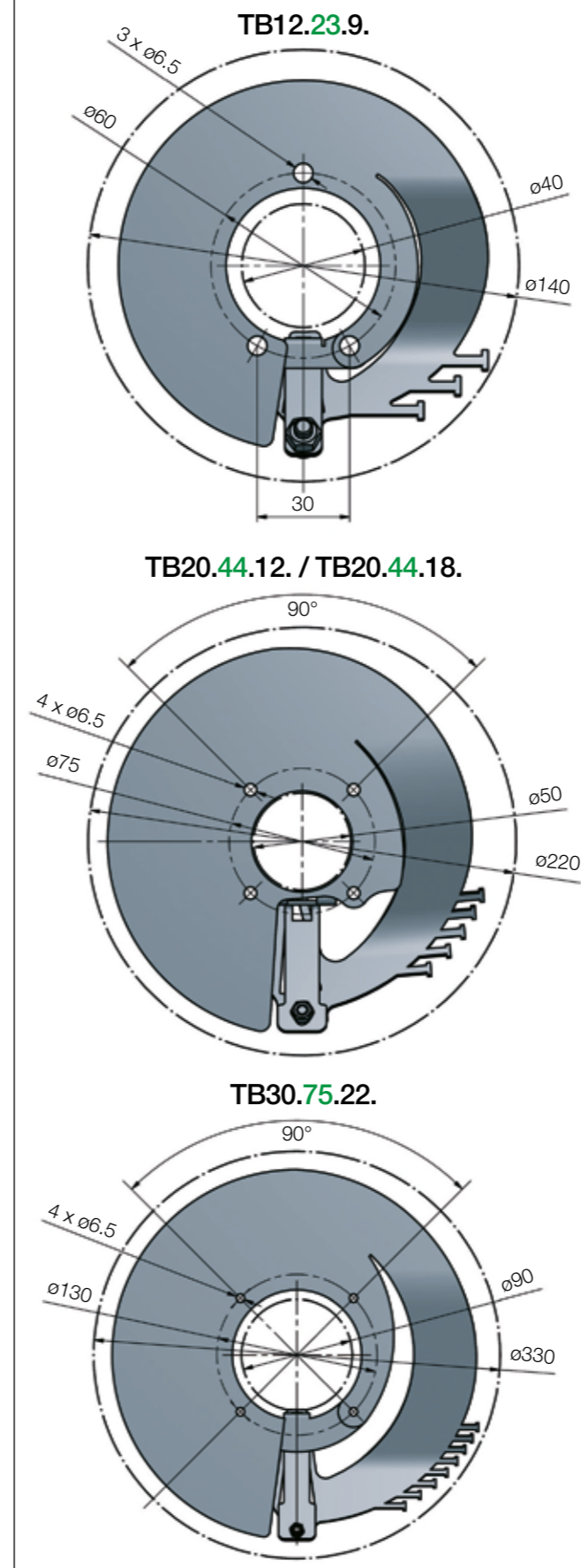

Base plates are delivered as standard as part of the twisterband module!

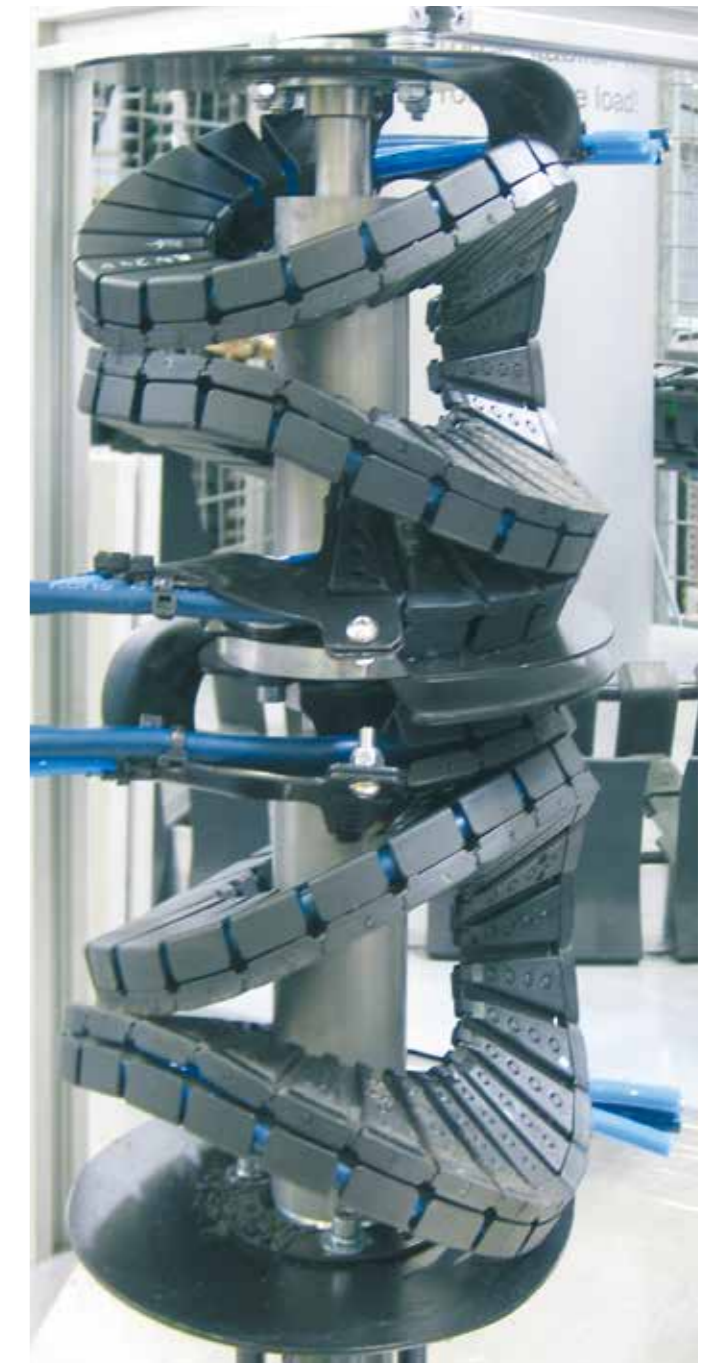

twisterband application of two systems mounted above one another. This space-saving solution allows double filling space with a constant outer diameter of the system



e-chain® links with strong pin and hook connection

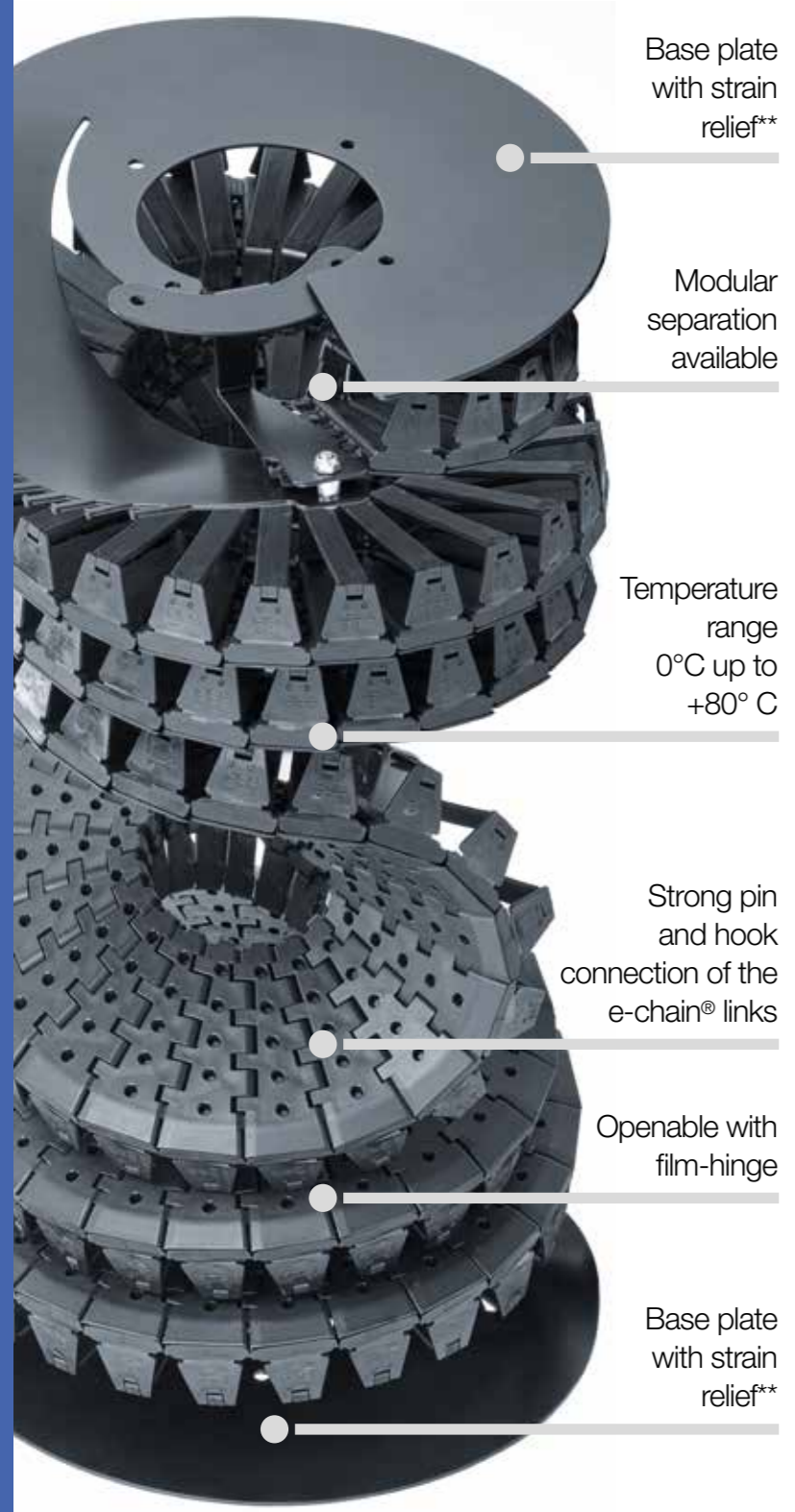

Base plate with strain relief\*\*

Modular separation available

Temperature range 0°C up to +80° C

Strong pin and hook connection of the e-chain® links

Openable with film-hinge

Base plate with strain relief\*\*

## Rotary movement in the most confined spaces, now even stronger - twisterband HD

Instead of strips, the twisterband HD has a strong pin/hook connection between the e-chain® links. Longer service life and higher filling are possible.

- Continuous cable guidance in rotational movements
- Strong pin/hook connection for high load and long service life
- For routing of electrical, fibre optic and pneumatic cables in one system
- Stop-dogs for defined bend radius
- Cable-friendly due to defined radius stop
- Max. rotating speed: 180°/s

### Typical industries and applications

- Machining heads on machine tools
- Rotary tables
- Axis 6 on robots
- Generally all applications that currently work with slip rings

\*\*Base plates are delivered as standard as part of the twisterband module!



twisterband | Openable with film hinge

Part No.	<i>Bi1</i>	<i>hi</i>	$X_1$	$X_2$	$\geq R$	$\leq R$	$\leq d1$	Opening principle
twisterband	[mm]	[mm]	ø [mm]	ø [mm]	[mm]	[mm]	[mm]	
TBHD30.75 .22. <b>XXX</b> .01.0	75	22	90	330	044	077	17	lock
TBHD42.135.30. <b>XXX</b> .01.0	135	30	90	500	056	119	20	lock

Base plates are delivered as standard as part of the twisterband module!

$X_1$  = ø inner machine installation space  $X_2$  = ø outer machine installation space

Complete Part No. with required number of strips **XXX**. Example: TBHD30.75.22.180.01.0

### Installation dimensions

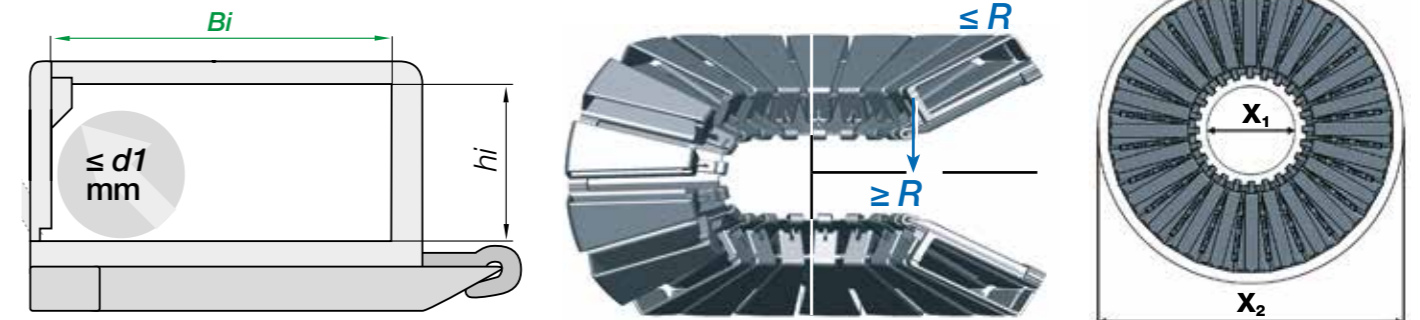

Available from stock. Ready to ship in 24 - 48hrs.\*

\*The delivery times indicated correspond to the average time until the ordered goods are dispatched.

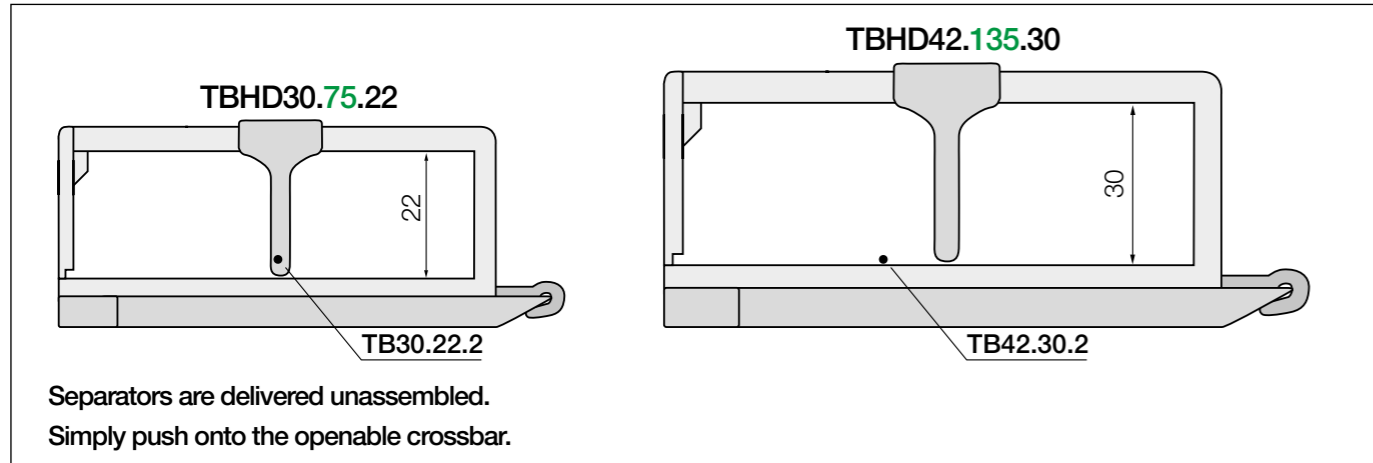

Separators are delivered unassembled.  
Simply push onto the openable crossbar.

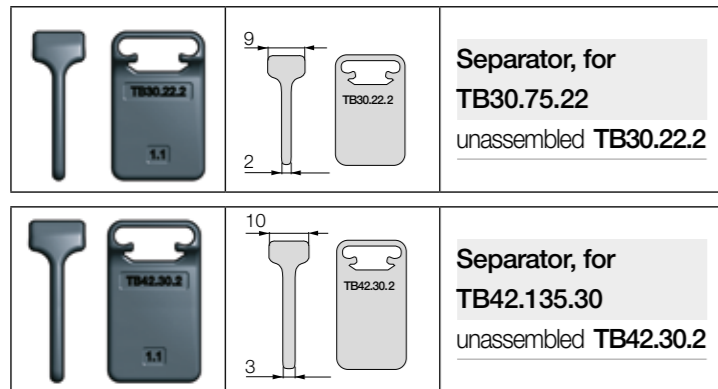

**Separators**

To fit, simply open the e-chain®, insert a cable and press the separator onto the crossbar. Then add more cables. The separators provide a clear, cable-friendly interior separation.



Easy opening and filling of the twisterband with a click or with the "easy" design. Simply press separators on and add more cables. The separators provide a clear, cable-friendly interior separation.



igus® twisterband and other e-chains® in a wood working machine

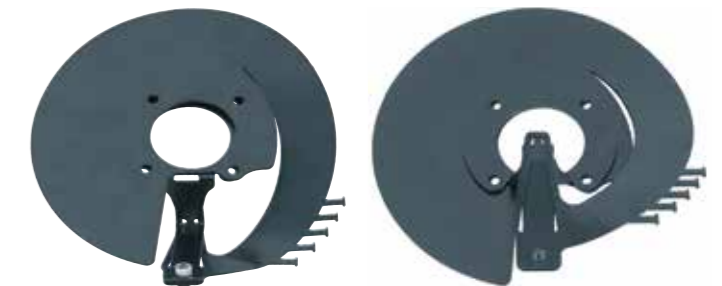
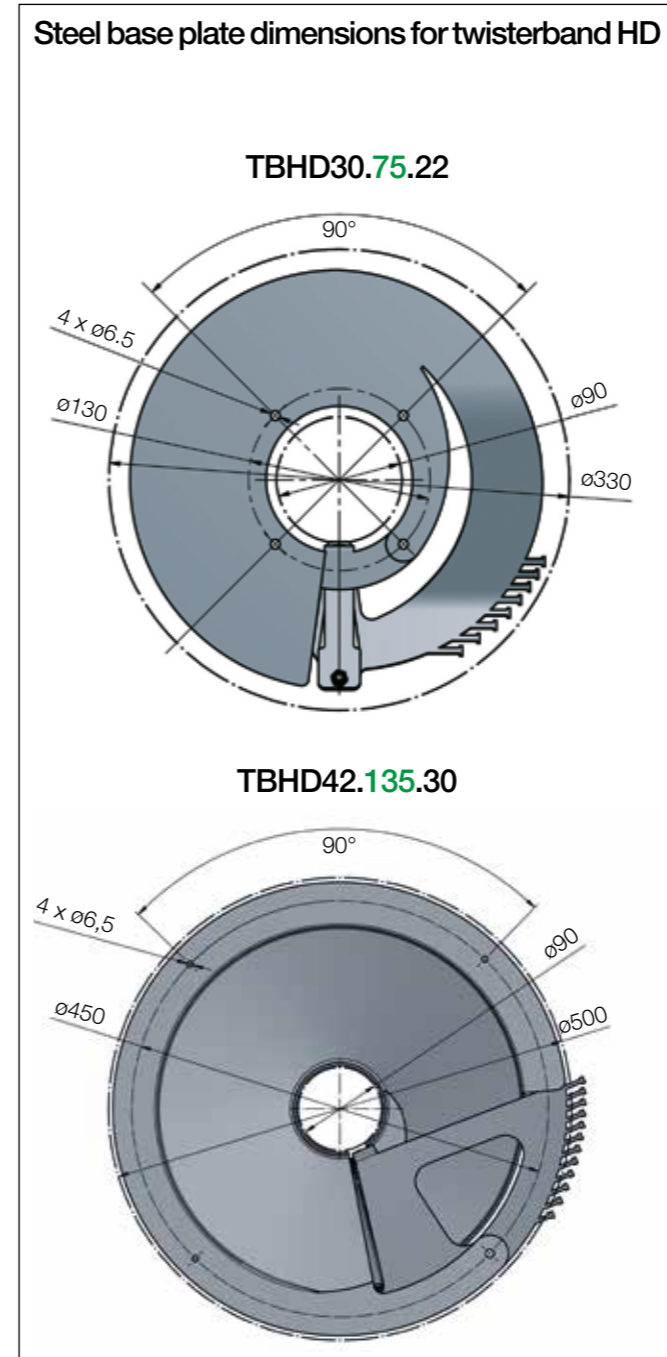

Base plates are delivered as standard as part of the twisterband module!